

PART NUMBER	REV	TERMINATOR	FEED TYPE	DESCRIPTION
1528836-1	A	LEADMAKER	MECH POST FEED	CUTS CARRIER
1528836-2	A	BENCH	MECH PRE FEED	CUTS CARRIER
1528836-6	A	LEADMAKER	MECH POST FEED	CONTINUOUS CARRIER
7-1528836-1	A	LEADMAKER	MECH POST FEED	-1 AND SPARE PARTS
7-1528836-2	A	BENCH	MECH PRE FEED	-2 AND SPARE PARTS
7-1528836-6	A	LEADMAKER	MECH POST FEED	-6 AND SPARE PARTS
7-1528836-7	A	-	-	SPARE PARTS KIT

CRIMP DATA		KOSTAL TERMINAL		KOSTAL CRIMP SPECS	
TERMINAL NAME: MLK 1.2 RECEPTACLE					
CRIMP	SIZE	TYPE	RANGE		
WIRE	1.17 [0.046 IN]	F	0.10-0.22mm ² or 26 AWG		
INSUL	1.57 [0.062 IN]	O	1.00-1.50 [0.039-0.059 IN]		
WIRE STRIP LENGTH		APPL INSTRUCTIONS			
3.10-3.40 [0.122-0.134 IN]		408-8322 & 408-8490			
TERMINAL APPL SPEC		KOSTAL DATA SHT		FEED	
MLK 1.2		-		8.00 [0.315 IN]	
TERMINALS APPLIED					
TE TERM PN	MANUF TERM PN				
1949523-1	2 21 24 49263 0				
1949523-2	2 21 25 49263 0				
1949523-3	2 21 40 49263 0				
WIRE SIZE	CRIMP HEIGHT	REF SETTING			
0.14mm ² or 26AWG	0.73 ± 0.03 [0.029 ± 0.001 IN]	B 9			

- △ RECOMMENDED SPARE PARTS.
- 2. GREASE RAM, CAM, CAM FOLLOWER AND FEED ROD LIGHTLY.
- △ CERTAIN TERMINALS REQUIRE LUBRICATION. REFER TO THE APPLICATOR INSTRUCTION SHEET FOR MORE INFORMATION.
- 4. LUBRICATE DAILY PER THE APPLICATOR INSTRUCTION SHEET SUPPLIED WITH THE APPLICATOR.
- △ CRIMP DATA SUPPLIED BY THE TERMINAL MANUFACTURER.
- △ WIRE AND INSULATION RANGES ARE THAT OF THE TERMINAL.
- △ CUT TO LENGTH AT ASSEMBLY.

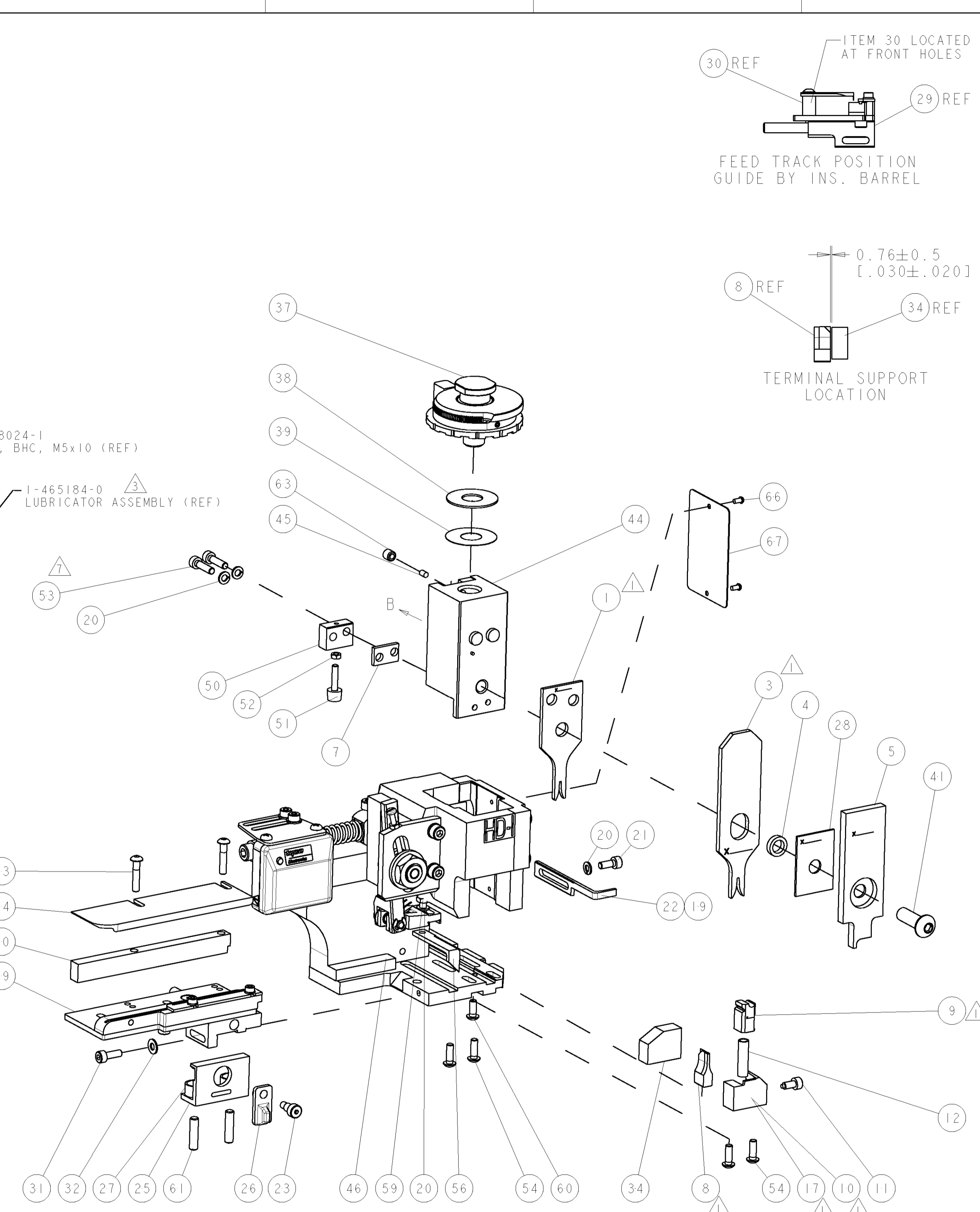

* WARNING
ON INSTALLATION, SET WIRE DISC TO LARGEST WIRE SIZE SETTING. USE OF SETTINGS BELOW MIN. REQUIRED CRIMP HEIGHT SETTING WILL CAUSE DAMAGE TO CRIMP TOOLING.

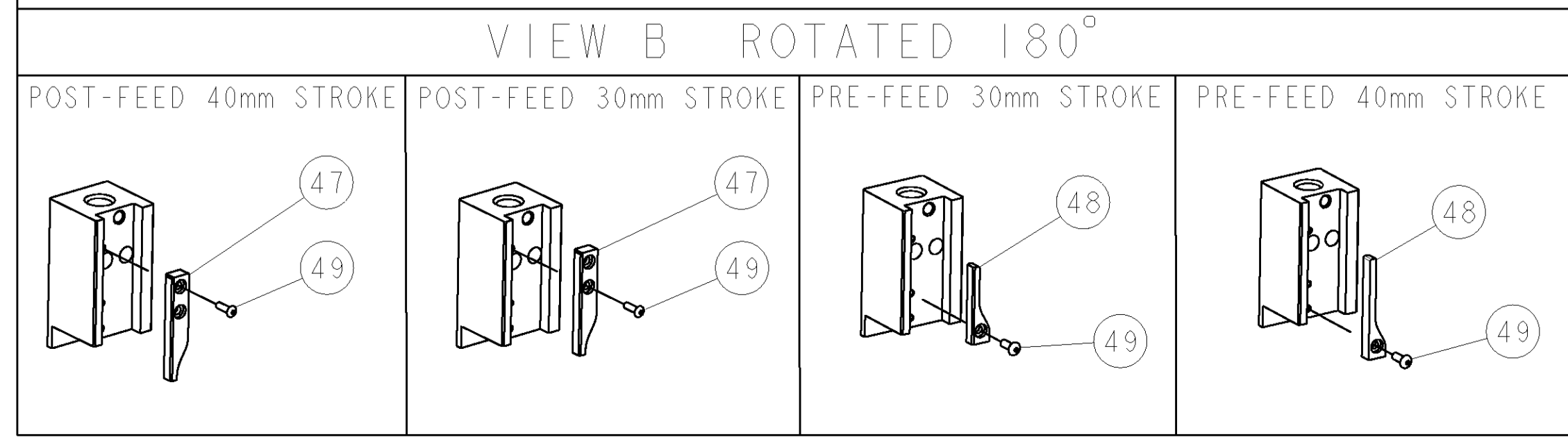

77	76	72	71	6	2	1	PART NO	DESCRIPTION	ITEM NO
-	-	-	-	-	-	-	-	-	84
-	-	-	-	-	-	-	-	-	83
-	-	-	-	-	-	-	-	-	82
-	-	-	-	-	-	-	-	-	81
-	-	-	-	-	-	-	-	-	80
-	-	-	-	-	-	-	-	-	79
-	-	-	-	-	-	-	-	-	78
-	-	-	-	-	-	-	-	-	77
-	-	-	-	-	-	-	-	-	76
-	-	-	-	-	-	-	-	-	75
-	-	-	-	-	-	-	-	-	74

SET UP GAGE 458637-3		LOC	DIST	REVISONS			
A	66			REV	DATE	BY	APPD
				A	SEE ECO-07-024492	17OCT2007	LJL MC

REV	DATE	BY	APPD	DESCRIPTION	ITEM NO			
-	-	-	-	-	73			
-	-	-	-	-	72			
-	1	1	1	1	1	1338705-3	DOCUMENTATION PACKAGE	71
-	-	-	-	-	-	-	-	70
-	-	-	-	-	-	-	-	69
-	-	-	-	-	-	-	-	68
-	1	1	1	1	1	461264-5	PLATE, IDENTIFICATION	67
-	2	2	2	2	2	21017-2	SCREW, DRIVE	66
-	-	-	-	-	-	-	-	65
-	-	-	-	-	-	-	-	64
-	1	1	1	1	1	3-18031-0	SCR, SET, CUP POINT M6 X 6.0	63
-	-	-	-	-	-	-	-	62
-	2	2	2	2	2	2-18032-5	SCR, SET, FLT POINT M5 X 20.0	61
-	1	1	1	1	1	18024-7	SCR, BTN SKT HD CAP (M4 X 10.0)	60
-	1	1	1	1	1	5-18022-2	SCR, HEX HD CAP M4 X 8.0	59
-	-	-	-	-	-	-	-	58
-	-	-	-	-	-	-	-	57
-	1	1	1	1	1	1338685-1	PAWL, FEED	56
-	-	-	-	-	-	-	-	55
-	4	4	4	4	4	18024-8	SCR, BTN SKT HD CAP (M4 X 12.0)	54
-	2	2	2	2	2	1-18023-3	SCR, SKT HD CAP M4 X 16.0	53
-	1	1	1	1	1	18030-1	NUT, HEX, REG M3	52
-	1	1	1	1	1	811242-5	BUMPER, HOLD DOWN	51
-	1	1	1	1	1	690753-2	SPACER, TONKER	50
-	1	1	1	1	1	18024-3	SCR, BTN SKT HD CAP (M3 X 10.0)	49
-	1	1	1	1	1	1338675-1	CAM, UNIVERSAL PRE FEED	48
-	1	1	1	1	1	1338676-1	CAM, UNIVERSAL POST-FEED	47
-	1	1	1	1	1	1320999-3	APPLICATOR SUBASSEMBLY, HDI	46
-	1	1	1	1	1	690191-1	PLUG, NYLON	45
-	1	1	1	1	1	1338660-1	RAM	44
-	-	-	-	-	-	-	-	43
-	-	-	-	-	-	-	-	42
-	1	1	1	1	1	2-18024-6	SCR, BTN SKT HD CAP (M8 X 25.0)	41
-	-	-	-	-	-	-	-	40
-	1	1	1	1	1	690125-1	SHIM SUB-ASSY	39
-	1	1	1	1	1	469367-7	SHIM	38
-	1	1	1	1	1	879103-3	FINE ADJUST HEAD ASSEMBLY	37
-	-	-	-	-	-	-	-	36
-	-	-	-	-	-	-	-	35
-	1	1	1	1	1	2-1320934-5	SUPPORT, TERMINAL	34
-	2	2	2	2	2	1-18024-0	SCR, BTN SKT HD CAP (M4 X 20.0)	33
-	1	1	1	1	1	18027-2	WASHER, FLAT, REG M4	32
-	1	1	1	1	1	1-18023-2	SCR, SKT HD CAP M4 X 12.0	31
-	1	1	1	1	1	1-1320908-7	SPACER, STRIP GUIDE	30
-	1	1	1	1	1	1-1633073-3	STRIP GUIDE ASSEMBLY	29
-	1	1	1	1	1	1-455888-0	SPACER, CRIMPER	28
-	2	2	2	2	2	1-22284-0	SPRING, COMPRESSION	27
-	1	1	1	1	1	356835-1	LEVER, DRAG RELEASE	26
-	1	1	1	1	1	240792-1	DRAG, TERMINAL	25
-	1	1	1	1	1	1320928-1	PLATE, STRIP GUIDE	24
-	1	1	1	1	1	980371-4	SCR, SKT HD SHLDR 5.0 DIA X 6.0	23
-	1	1	1	1	1	690472-2	STRIPPER	22
-	1	1	1	1	1	1-18023-1	SCR, SKT HD CAP M4 X 10.0	21
-	4	4	4	4	4	18025-2	WASHER, SPRG LOCK, REG M4	20
-	1	1	1	1	1	690472-1	STRIPPER	19
-	-	-	-	-	-	-	-	18
-	1	1	1	1	1	1338684-1	SHEAR HOLDER, FRONT	17
-	-	-	-	-	-	-	-	16
-	-	-	-	-	-	-	-	15
-	-	-	-	-	-	-	-	14
-	-	-	-	-	-	-	-	13
-	1	1	1	1	1	3-22280-3	SPRING, COMPRESSION	12
-	1	1	1	1	1	356885-4	STOP, SHEAR	11
-	1	1	1	1	1	1320921-1	SHEAR HOLDER, FRONT, CUT	10
-	1	1	1	1	1	462006-1	FLOATING SHEAR, FRONT	9
1	2	2	2	1	1	6-1633138-9	ANVIL, COMBINATION	8
-	1	1	1	1	1	8-240641-6	SPACER	7
-	-	-	-	-	-	-	-	6
-	1	1	1	1	1	2-455889-0	DEPRESSOR, SHEAR	5
-	1	1	1	1	1	238011-2	BLOCK, CRIMPER SPACER	4
1	2	2	2	1	1	1-1633510-5	CRIMPER, INSUL O	3
-	-	-	-	-	-	-	-	2
1	2	2	2	1	1	5-568176-2	CRIMPER, WIRE	1