

ISL54206

MP3/USB 2.0 High Speed Switch with Negative Signal Handling

FN6409
 Rev 0.00
 December 18, 2006

The Intersil ISL54206 dual SPDT (Single Pole/Double Throw) switches combine low distortion audio and accurate USB 2.0 high speed data (480Mbps) signal switching in the same low voltage device. When operated with a 2.7V to 3.6V single supply these analog switches allow audio signal swings below-ground, allowing the use of a common USB and audio headphone connector in Personal Media Players and other portable battery powered devices.

The ISL54206 logic control pins are 1.8V compatible which allows for control via a standard μ controller. With a VDD voltage in the range of 2.7V to 3.6V the IN pin voltage can exceed the VDD rail allowing for the USB 5V VBUS voltage from a computer to directly drive the IN pin to switch between the audio and USB signal sources in the portable device. The part has an audio enable control pin to open all the switches and put the part in a low power state.

The ISL54206 is available in a small 10 Ld 2.1mmx1.6mm ultra-thin μ TQFN package and a 10 Ld 3mmx3mm TDFN package. It operates over a temperature range of -40 to +85°C.

Related Literature

- Technical Brief TB363 "Guidelines for Handling and Processing Moisture Sensitive Surface Mount Devices (SMDs)"
- Application Note AN557 "Recommended Test Procedures for Analog Switches"

Features

- High Speed (480Mbps) Signaling Capability per USB 2.0
- Low Distortion Negative Signal Capability
- Control Pin to Open all Switches and Enter Low Power State
- Low Distortion Headphone Audio Signals
 - THD+N at 20mW into 32 Ω Load <0.1%
- Cross-talk Audio Channels (20Hz to 20kHz) -110dB
- Single Supply Operation (V_{DD}) 1.8V to 5.5V
- -3dB Bandwidth USB Switches 630MHz
- Available in μ TQFN and TDFN Packages
- Pb-Free Plus Anneal (RoHS Compliant)
- Compliant with USB 2.0 Short Circuit Requirements Without Additional External Components

Applications

- MP3 and Other Personal Media Players
- Cellular/Mobile Phones
- PDA's
- Audio/USB Switching

Application Block Diagram

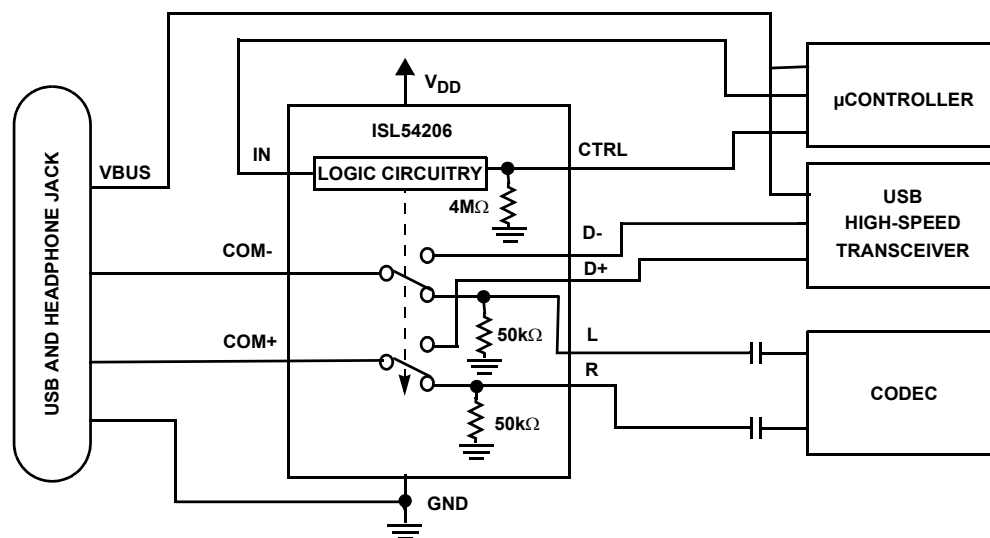

Pinouts (Note 1)

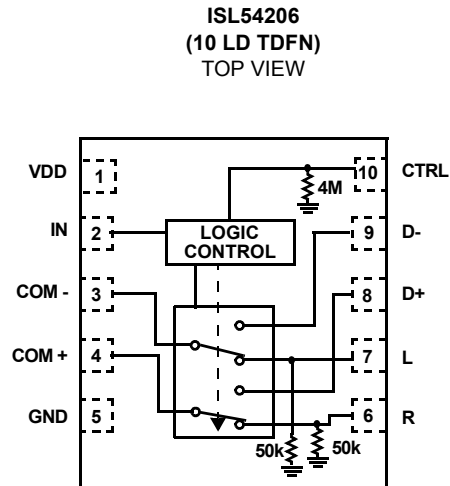
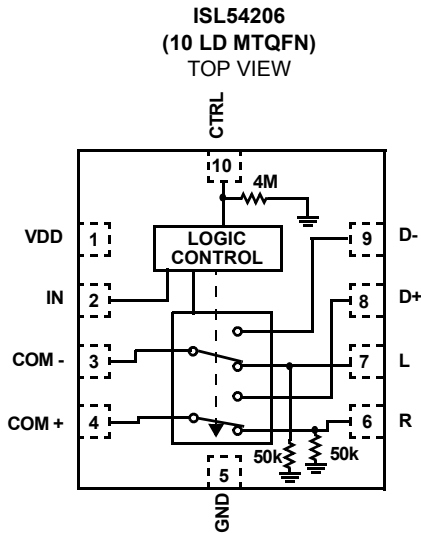

NOTE:

1. ISL54206 Switches shown for IN = Logic "0" and CTRL = Logic "1".

Truth Table

ISL54206			
IN	CTRL	L, R	D+, D-
0	0	OFF	OFF
0	1	ON	OFF
1	X	OFF	ON

IN: Logic "0" when $\leq 0.5V$, Logic "1" when $\geq 1.4V$ with 2.7V to 3.6V supply.
 CTRL: Logic "0" when $\leq 0.5V$ or Floating, Logic "1" when $\geq 1.4V$ with 2.7V to 3.6V supply.

Pin Descriptions

ISL54206		
PIN NO.	NAME	FUNCTION
1	VDD	Power Supply
2	IN	Digital Control Input
3	COM-	Voice and Data Common Pin
4	COM+	Voice and Data Common Pin
5	GND	Ground Connection
6	R	Audio Right Input
7	L	Audio Left Input
8	D+	USB Differential Input
9	D-	USB Differential Input
10	CTRL	Digital Control Input (Audio Enable)

Ordering Information

PART NUMBER (Note)	PART MARKING	TEMP. RANGE (°C)	PACKAGE (Pb-Free)	PKG. DWG. #
ISL54206IRUZ-T	FN	-40 to +85	10 Ld 2.1x1.6mm μ TQFN Tape and Reel	L10.2.1x1.6A
ISL54206IRZ-T	061Z	-40 to +85	10 Ld 3mmx3mm TDFN Tape and Reel	L10.3x3A
ISL54206IRZ	061Z	-40 to +85	10 Ld 3mmx3mm TDFN	L10.3x3A

NOTE: Intersil Pb-free plus anneal products employ special Pb-free material sets; molding compounds/die attach materials and 100% matte tin plate or NiPdAu termination finish, which are RoHS compliant and compatible with both SnPb and Pb-free soldering operations. Intersil Pb-free products are MSL classified at Pb-free peak reflow temperatures that meet or exceed the Pb-free requirements of IPC/JEDEC J STD-020.

Absolute Maximum Ratings

VDD to GND	-0.3 to 6.0V
Input Voltages	
D+, D-, L, R (Note 2)	-2V to ((V _{DD}) + 0.3V)
IN (Note 2)	-2V to 5.5V
CTRL (Note 2)	-0.3 to ((V _{DD}) + 0.3V)
Output Voltages	
COM-, COM+ (Note 2)	-2V to ((V _{DD}) + 0.3V)
Continuous Current (Audio Switches)	±150mA
Peak Current (Audio Switches)	
(Pulsed 1ms, 10% Duty Cycle, Max)	±300mA
Continuous Current (USB Switches)	±40mA
Peak Current (USB Switches)	
(Pulsed 1ms, 10% Duty Cycle, Max)	±100mA
ESD Rating:	
HBM	>7kV
MM	>400V
CDM	>1.4kV

CAUTION: Stresses above those listed in "Absolute Maximum Ratings" may cause permanent damage to the device. This is a stress only rating and operation of the device at these or any other conditions above those indicated in the operational sections of this specification is not implied.

NOTES:

- Signals on D+, D-, L, R, COM-, COM+, CTRL, IN exceeding V_{DD} or GND by specified amount are clamped. Limit current to maximum current ratings.
- θ_{JA} is measured with the component mounted on a high effective thermal conductivity test board in free air. See Tech Brief TB379 for details.

Electrical Specifications - 2.7V to 3.6V Supply Test Conditions: V_{DD} = +3.3V, GND = 0V, V_{INH} = 1.4V, V_{INL} = 0.5V, V_{CTRLH} = 1.4V, V_{CTRL} = 0.5V, (Notes 4, 6), unless otherwise specified.

PARAMETER	TEST CONDITIONS	TEMP (°C)	(NOTE 5) MIN	TYP	(NOTE 5) MAX	UNITS
ANALOG SWITCH CHARACTERISTICS						
Audio Switches (L, R)						
Analog Signal Range, V _{ANALOG}	V _{DD} = 3.0V, IN = 0.5V, CTRL = 1.4V	Full	-1.5	-	1.5	V
ON Resistance, R _{ON}	V _{DD} = 3.0V, IN = 0.5V, CTRL = 1.4V, I _{COMx} = 100mA, V _L or V _R = -0.85V to 0.85V, (See Figure 3)	25	-	2.65	4	Ω
		Full	-	-	5.5	Ω
R _{ON} Matching Between Channels, ΔR _{ON}	V _{DD} = 3.0V, IN = 0.5V, CTRL = 1.4V, I _{COMx} = 100mA, V _L or V _R = Voltage at max R _{ON} over signal range of -0.85V to 0.85V, (Note 8)	25	-	0.02	0.13	Ω
		Full	-	-	0.16	Ω
R _{ON} Flatness, R _{FLAT(ON)}	V _{DD} = 3.0V, IN = 0.5V, CTRL = 1.4V, I _{COMx} = 100mA, V _L or V _R = -0.85V to 0.85V, (Note 7)	25	-	0.03	0.05	Ω
		Full	-	-	0.07	Ω
Discharge Pull-Down Resistance, R _L , R _R	V _{DD} = 3.6V, IN = 0V, CTRL = 3.6V, V _{COM-} or V _{COM+} = -0.85V, 0.85V, V _L or V _R = -0.85V, 0.85V, V _{D+} and V _{D-} = floating, Measure current through the discharge pull-down resistor and calculate resistance value.	25	-	50	-	kΩ
USB Switches (D+, D-)						
Analog Signal Range, V _{ANALOG}	V _{DD} = 3.6V, IN = 1.4V, CTRL = 1.4V	Full	0	-	V _{DD}	V
ON Resistance, R _{ON}	V _{DD} = 3.6V, IN = 1.4V, CTRL = 1.4V, I _{COMx} = 40mA, V _{D+} or V _{D-} = 0V to 400mV (See Figure 4)	25	-	4.6	5	Ω
		Full	-	-	6.5	Ω
R _{ON} Matching Between Channels, ΔR _{ON}	V _{DD} = 3.6V, IN = 1.4V, CTRL = 1.4V, I _{COMx} = 40mA, V _{D+} or V _{D-} = Voltage at max R _{ON} , (Note 7)	25	-	0.06	0.5	Ω
		Full	-	-	0.55	Ω
R _{ON} Flatness, R _{FLAT(ON)}	V _{DD} = 3.6V, IN = 1.4V, CTRL = 1.4V, I _{COMx} = 40mA, V _{D+} or V _{D-} = 0V to 400mV, (Note 7)	25	-	0.4	0.6	Ω
		Full	-	-	1.0	Ω
OFF Leakage Current, I _{D+(OFF)} or I _{D-(OFF)}	V _{DD} = 3.6V, IN = 0V, CTRL = 3.6V, V _{COM-} or V _{COM+} = 0.5V, 0V, V _{D+} or V _{D-} = 0V, 0.5V, V _L and V _R = float	25	-10	-	10	nA
		Full	-70	-	70	nA

Thermal Information

Thermal Resistance (Typical, Note 3)	θ _{JA} (°C/W)
10 Ld μTQFN Package	130
10 Ld 3x3 TDFN Package	110
Maximum Junction Temperature (Plastic Package)	+150°C
Maximum Storage Temperature Range	-65°C to +150°C

Operating Conditions

Temperature Range	-40°C to +85°C
-------------------	----------------

Electrical Specifications - 2.7V to 3.6V Supply Test Conditions: $V_{DD} = +3.3V$, $GND = 0V$, $V_{INH} = 1.4V$, $V_{INL} = 0.5V$, $V_{CTRLH} = 1.4V$, $V_{CTRL} = 0.5V$, (Notes 4, 6), unless otherwise specified. **(Continued)**

PARAMETER	TEST CONDITIONS	TEMP (°C)	(NOTE 5) MIN	TYP	(NOTE 5) MAX	UNITS
ON Leakage Current, I_{Dx}	$V_{DD} = 3.3V$, $IN = 3.3V$, $CTRL = 0V$ or $3.3V$, V_{D+} or $V_{D-} = 2.0V$, V_{COM-} , V_{COM+} , V_L and $V_R = \text{float}$	25	-10	2	10	nA
		Full	-75	-	75	nA
DYNAMIC CHARACTERISTICS						
Turn-ON Time, t_{ON}	$V_{DD} = 2.7V$, $R_L = 50\Omega$, $C_L = 10pF$, (See Figure 1)	25	-	67	-	ns
Turn-OFF Time, t_{OFF}	$V_{DD} = 2.7V$, $R_L = 50\Omega$, $C_L = 10pF$, (See Figure 1)	25	-	48	-	ns
Break-Before-Make Time Delay, t_D	$V_{DD} = 2.7V$, $R_L = 50\Omega$, $C_L = 10pF$, (See Figure 2)	25	-	18	-	ns
Skew, t_{SKEW}	$V_{DD} = 3.3V$, $IN = 3.3V$, $CTRL = 0V$ or $3.3V$, $R_L = 45\Omega$, $C_L = 10pF$, $t_R = t_F = 750ps$ at 480Mbps, (Duty Cycle = 50%) (See Figure 7)	25	-	50	-	ps
Total Jitter, t_j	$V_{DD} = 3.3V$, $IN = 3.3V$, $CTRL = 0V$ or $3.3V$, $R_L = 45\Omega$, $C_L = 10pF$, $t_R = t_F = 750ps$ at 480Mbps	25	-	210	-	ps
Propagation Delay, t_D	$V_{DD} = 3.3V$, $IN = 3.3V$, $CTRL = 0V$ or $3.3V$, $R_L = 45\Omega$, $C_L = 10pF$, (See Figure 7)	25	-	250	-	ps
Crosstalk (Channel-to-Channel), R to COM-, L to COM+	$V_{DD} = 3.3V$, $IN = 0V$, $CTRL = 3.3V$, $R_L = 32\Omega$, $f = 20Hz$ to $20kHz$, V_R or $V_L = 0.707V_{RMS}$ ($2V_{P-P}$), (See Figure 6)	25	-	-110	-	dB
Total Harmonic Distortion	$f = 20Hz$ to $20kHz$, $V_{DD} = 3.0V$, $IN = 0V$, $CTRL = 3.0V$, V_L or $V_R = 0.707V_{RMS}$ ($2V_{P-P}$), $R_L = 32\Omega$	25	-	0.06	-	%
USB Switch -3dB Bandwidth	Signal = 0dBm, $0.2V_{DC}$ offset, $R_L = 50\Omega$, $C_L = 5pF$	25	-	630	-	MHz
D+/D- OFF Capacitance, $C_{D+(OFF)}$, $C_{D-(OFF)}$	$f = 1MHz$, $V_{DD} = 3.3V$, $IN = 0V$, $CTRL = 3.3V$, V_{D-} or $V_{D+} = V_{COMx} = 0V$, (See Figure 5)	25	-	6	-	pF
L/R OFF Capacitance, C_{LOFF} , C_{ROFF}	$f = 1MHz$, $V_{DD} = 3.3V$, $IN = 0V$, $CTRL = 0V$ or $3.3V$, V_L or $V_R = V_{COMx} = 0V$, (See Figure 5)	25	-	9	-	pF
COM ON Capacitance, $C_{COM-(ON)}$, $C_{COM+(ON)}$	$f = 1MHz$, $V_{DD} = 3.3V$, $IN = 3.0V$, $CTRL = 0V$ or $3.3V$, V_{D-} or $V_{D+} = V_{COMx} = 0V$, (See Figure 5)	25	-	10	-	pF
POWER SUPPLY CHARACTERISTICS						
Power Supply Range, V_{DD}		Full	1.8	-	5.5	V
Positive Supply Current, I_{DD}	$V_{DD} = 3.6V$, $IN = 0V$ or $3.6V$, $CTRL = 3.6V$	25	-	6	8	μA
		Full	-	-	10	μA
Positive Supply Current, I_{DD} (Low Power State)	$V_{DD} = 3.6V$, $IN = 0V$, $CTRL = 0V$ or float	25	-	1	7	nA
		Full	-	-	140	nA
DIGITAL INPUT CHARACTERISTICS						
Voltage Low, V_{INL} , V_{CTRL}	$V_{DD} = 2.7V$ to $3.6V$	Full	-	-	0.5	V
Voltage High, V_{INH} , V_{CTRLH}	$V_{DD} = 2.7V$ to $3.6V$	Full	1.4	-	-	V
Input Current, I_{INL} , I_{CTRL}	$V_{DD} = 3.6V$, $IN = 0V$, $CTRL = 0V$	Full	-50	20	50	nA
Input Current, I_{INH}	$V_{DD} = 3.6V$, $IN = 3.6V$, $CTRL = 0V$	Full	-50	20	50	nA
Input Current, I_{CTRLH}	$V_{DD} = 3.6V$, $IN = 0V$, $CTRL = 3.6V$	Full	-2	1.1	2	μA
CTRL Pull-Down Resistor, R_{CTRL}	$V_{DD} = 3.6V$, $IN = 0V$, $CTRL = 3.6V$	Full	-	4	-	M Ω

NOTES:

- V_{LOGIC} = Input voltage to perform proper function.
- The algebraic convention, whereby the most negative value is a minimum and the most positive a maximum, is used in this data sheet.
- Parameters with limits are 100% tested at +25°C. Limits across the full temperature range are guaranteed by design and correlation.
- Flatness is defined as the difference between maximum and minimum value of on-resistance over the specified analog signal range..
- R_{ON} matching between channels is calculated by subtracting the channel with the highest max R_{ON} value from the channel with lowest max R_{ON} value, between L and R or between D+ and D-.

Test Circuits and Waveforms

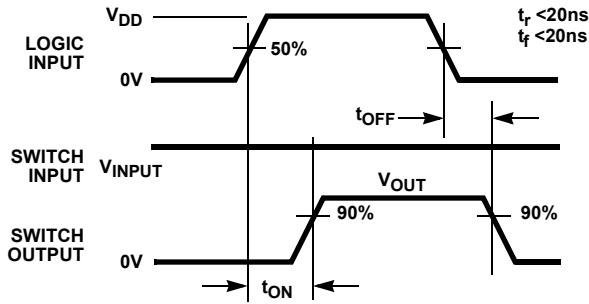

Logic input waveform is inverted for switches that have the opposite logic sense.

FIGURE 1A. MEASUREMENT POINTS

FIGURE 1. SWITCHING TIMES

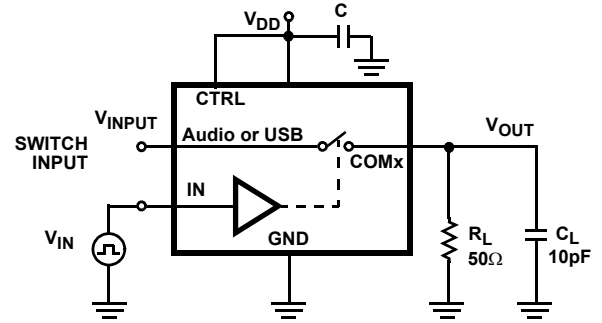

Repeat test for all switches. C_L includes fixture and stray capacitance.

$$V_{OUT} = V_{(INPUT)} \frac{R_L}{R_L + R_{(ON)}}$$

FIGURE 1B. TEST CIRCUIT

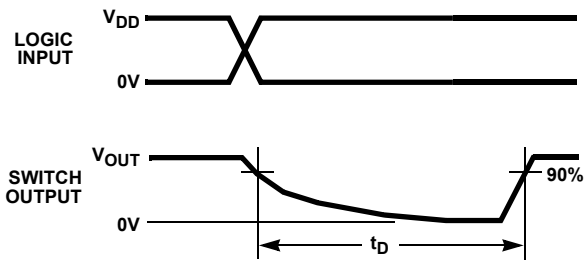
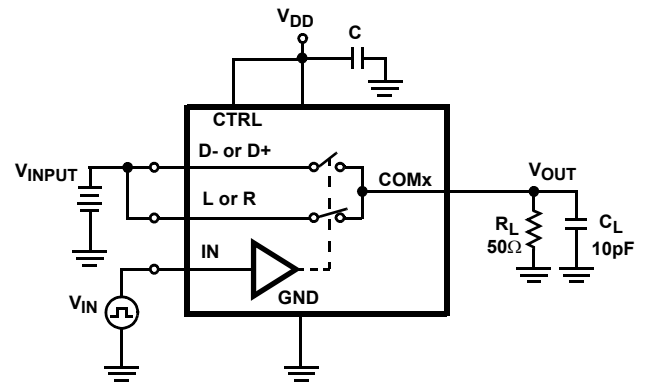

FIGURE 2A. MEASUREMENT POINTS

FIGURE 2. BREAK-BEFORE-MAKE TIME



Repeat test for all switches. C_L includes fixture and stray capacitance.

FIGURE 2B. TEST CIRCUIT

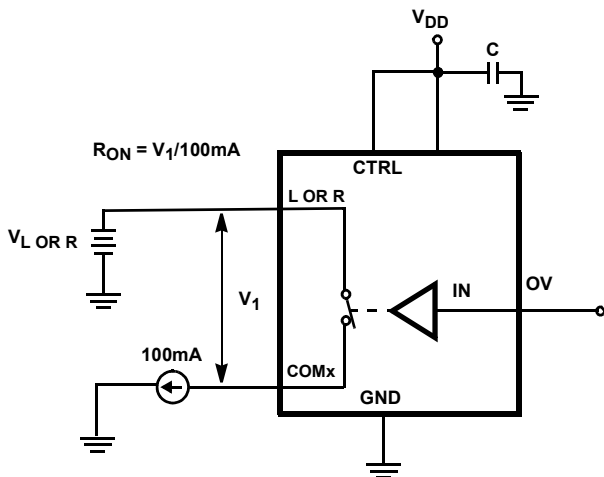

Repeat test for all switches.

FIGURE 3. AUDIO R_{ON} TEST CIRCUIT

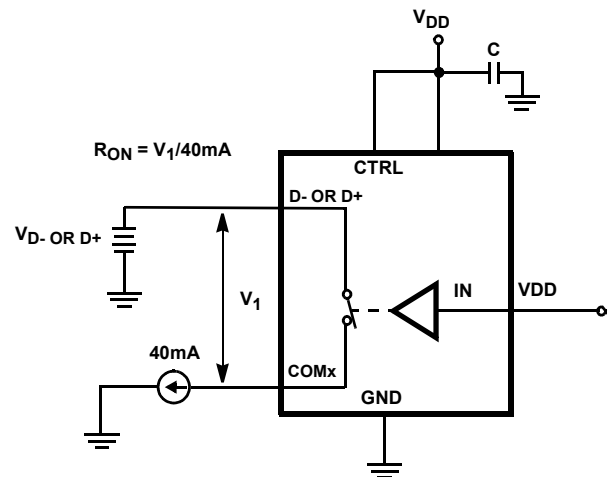

Repeat test for all switches.

FIGURE 4. USB R_{ON} TEST CIRCUIT

Test Circuits and Waveforms (Continued)

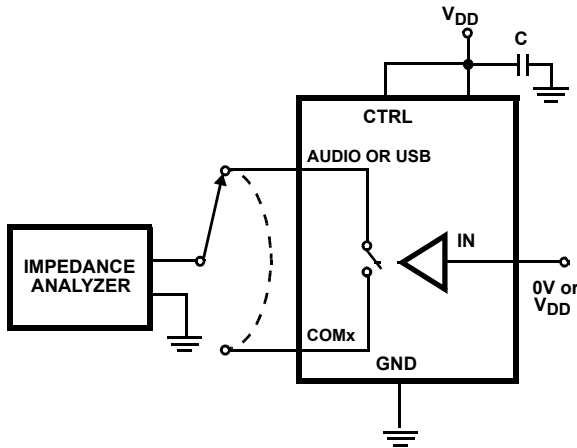

Repeat test for all switches.

FIGURE 5. CAPACITANCE TEST CIRCUIT

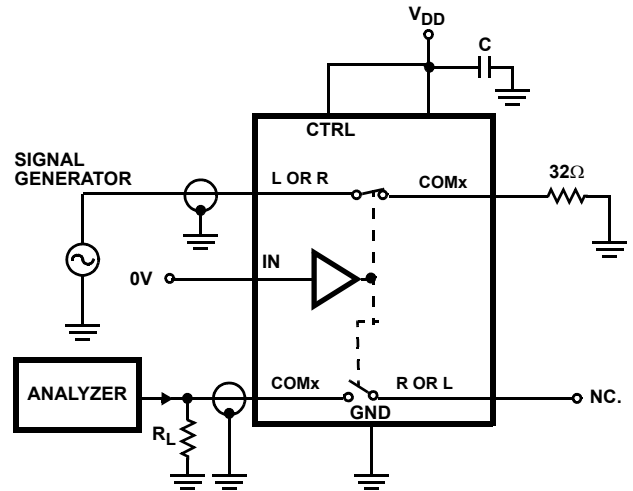

Signal direction through switch is reversed, worst case values are recorded. Repeat test for all switches.

FIGURE 6. AUDIO CROSSTALK TEST CIRCUIT

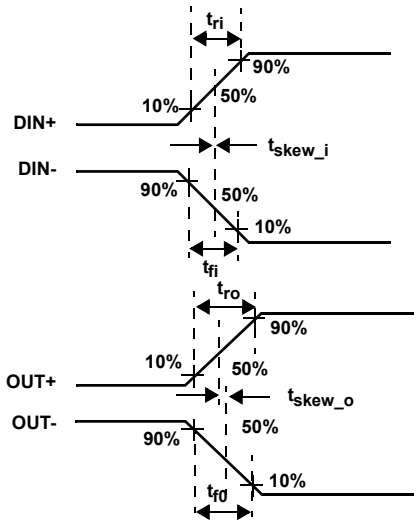
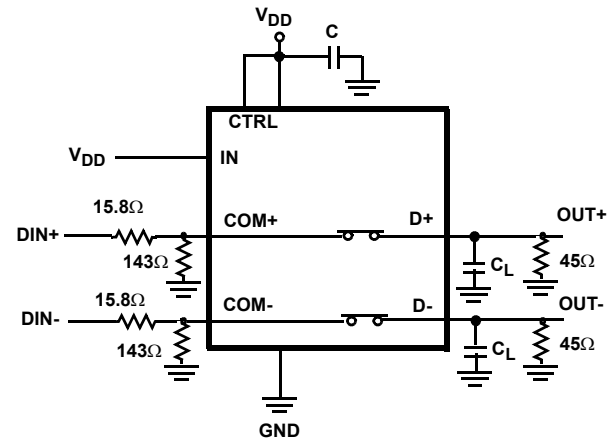

FIGURE 7A. MEASUREMENT POINTS



$|t_{ro} - t_{ri}|$ Delay Due to Switch for Rising Input and Rising Output Signals.
 $|t_{fo} - t_{fi}|$ Delay Due to Switch for Falling Input and Falling Output Signals.
 $|t_{skew_o}|$ Change in Skew through the Switch for Output Signals.
 $|t_{skew_i}|$ Change in Skew through the Switch for Input Signals.

FIGURE 7B. TEST CIRCUIT

FIGURE 7. SKEW TEST

Application Block Diagrams

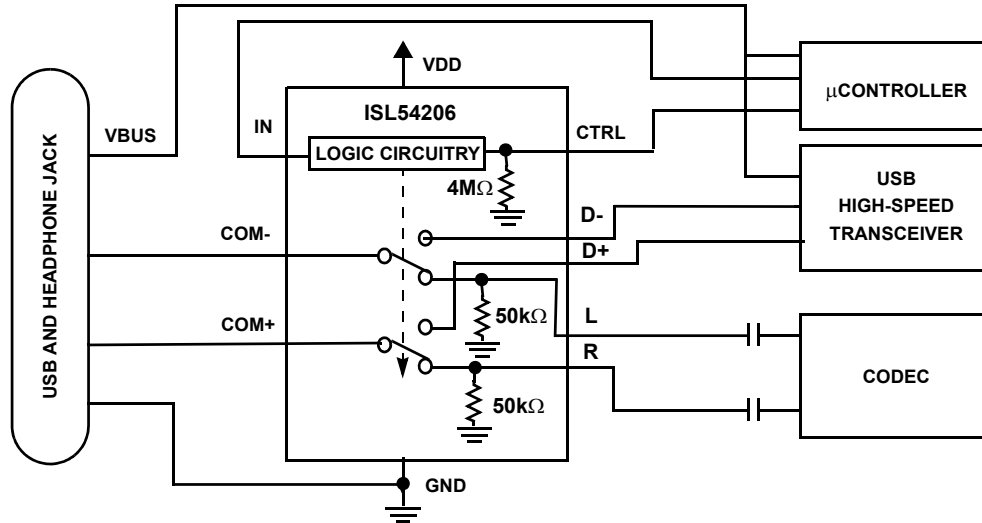

LOGIC CONTROL VIA MICRO-PROCESSOR

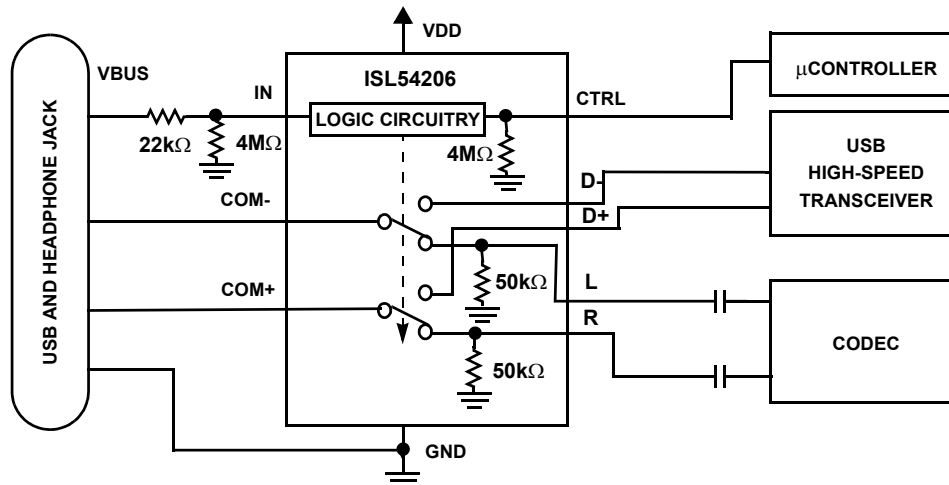

LOGIC CONTROL VIA VBUS VOLTAGE FROM COMPUTER OR USB HUB

Detailed Description

The ISL54206 device is a dual single pole/double throw (SPDT) analog switch device that can operate from a single dc power supply in the range of 1.8V to 5.5V. It was designed to function as a dual 2 to 1 multiplexer to select between USB differential data signals and audio L and R stereo signals. It comes in tiny μ TQFN and TDFN packages for use in MP3 players, PDAs, cell phones, and other personal media players.

The part consists of two 3Ω audio switches and two 5Ω USB switches. The audio switches can accept signals that swing below ground. They were designed to pass audio left and right stereo signals, that are ground referenced, with minimal distortion. The USB switches were designed to pass high-speed USB differential data signals with minimal edge and phase distortion.

The ISL54206 was specifically designed for MP3 players, cell phones and other personal media player applications that need to combine the audio headphone jack and the USB data connector into a single shared connector, thereby saving space and component cost. Typical application block diagrams of this functionality is shown above.

The ISL54206 has a single logic control pin (IN) that selects between the audio switches and the USB switches. This pin can be driven Low or High to switch between the audio CODEC drivers and USB transceiver of the MP3 player or cellphone. The ISL54206 also contains a logic control pin (CTRL) that when driven Low while IN is Low, opens all switches and puts the part into a low power state, drawing typically 1nA of I_{DD} current.

A detailed description of the two types of switches is provided in the sections following. The USB transmission

and audio playback are intended to be mutually exclusive operations.

Audio Switches

The two audio switches (L, R) are 3Ω switches that can pass signals that swing below ground by as much as 1.5V. They were designed to pass ground reference stereo signals with minimal insertion loss and very low distortion. Crosstalk between the audio switches over the audio band is $< -110\text{dB}$.

Over a signal range of $\pm 1\text{V}$ ($0.707\text{V}_{\text{rms}}$) with $V_{\text{DD}} > 2.7\text{V}$, these switches have an extremely low r_{ON} resistance variation. They can pass ground referenced audio signals with very low distortion ($< 0.06\%$ THD+N) when delivering 15.6mW into a 32Ω headphone speaker load. See Figures 8, Figures 9, Figures 10, and Figures 11 THD+N performance curves.

These switches are uni-directional switches. The audio drivers should be connected at the L and R side of the switch (pin 7 and pin 8) and the speaker loads should be connected at the COM side of the switch (pin 3 and pin 4).

The audio switches are active (turned ON) whenever the IN voltage is $\leq 0.5\text{V}$ and the CTRL voltage to $\geq 1.4\text{V}$.

Note: Whenever the audio switches are ON the USB transceivers need to be in the high impedance state or static high or low state.

USB Switches

The two USB switches (D+, D-) are 5Ω bidirectional switches that were designed to pass high-speed USB differential signals in the range of $\pm 0\text{V}$ to 400mV. These switches have low capacitance and high bandwidth to pass USB high-speed signals (480Mbps) with minimum edge and phase distortion to meet USB 2.0 high-speed signal quality specifications. See Figure 12 for High-speed Eye Pattern taken with switch in the signal path.

The maximum signal range for the USB switches is from -1.5V to V_{DD} . The signal voltage at D- and D+ should not be allowed to exceed the V_{DD} voltage rail or go below ground by more than -1.5V .

The USB switches are active (turned ON) whenever the IN voltage is $\geq 1.4\text{V}$.

Note: Whenever the USB switches are ON the audio drivers of the CODEC need to be at AC or DC ground or floating to keep from interfering with the data transmission.

ISL54206 Operation

The discussion that follows will discuss using the ISL54206 in the typical application shown in the block diagrams on page 7.

VDD SUPPLY

The DC power supply connected at VDD (pin 1) provides the required bias voltage for proper switch operation. The part

can operate with a supply voltage in the range of 1.8V to 5.5V.

In a typical USB/Audio application for portable battery powered devices the V_{DD} voltage will come from a battery or an LDO and be in the range of 2.7V to 3.6V. For best possible USB full-speed operation (12Mbps) it is recommended that the V_{DD} voltage be $\geq 3.3\text{V}$ in order to get a USB data signal level above 2.5V.

LOGIC CONTROL

The state of the ISL54206 device is determined by the voltage at the IN pin (pin 2) and the CTRL pin (pin 10). Refer to truth-table on page 2 of data sheet. These logic pins are 1.8V logic compatible when V_{DD} is in the range of 2.7V to 3.6V and can be controlled by a standard μ processor.

The CTRL pin is internally pulled low through a $4\text{M}\Omega$ resistor to ground and can be left floating or tri-stated by the μ processor. The CTRL control pin is only active when IN is logic "0".

The IN pin does not have an internal pull-down resistor and must not be allowed to float. It must be driven High or Low.

The voltage at the IN pin can exceed the V_{DD} voltage by as much as 2.55V. This allows the VBUS voltage from a computer or USB hub (4.4V to 5.25V) to drive the IN pin while the VDD voltage is in the range of 2.7V to 3.6V. An external pull-down resistor is required from the IN pin to ground when directly driving the IN pin with the computer VBUS voltage. See the section titled "USING THE COMPUTER VBUS VOLTAGE TO DRIVE THE 'IN' PIN".

Logic control voltage levels:

IN = Logic "0" (Low) when $\text{IN} \leq 0.5\text{V}$

IN = Logic "1" (High) when $\text{IN} \geq 1.4\text{V}$

CTRL = Logic "0" (Low) when $\leq 0.5\text{V}$ or floating.

CTRL = Logic "1" (High) when $\geq 1.4\text{V}$

Audio Mode

If the IN pin = Logic "0" and CTRL pin = Logic "1," the part will be in the Audio mode. In Audio mode the L (left) and R (right) 3Ω audio switches are ON and the D- and D+ 5Ω USB switches are OFF (high impedance).

When nothing is plugged into the common connector or a headphone is plugged into the common connector, the μ processor will sense that there is no voltage at the VBUS pin of the connector and will drive and hold the IN control pin of the ISL54206 low. As long as the CTRL = Logic "1," the ISL54206 part will be in the audio mode and the audio drivers of the media player can drive the headphones and play music.

USB Mode

If the IN pin = Logic "1" and CTRL pin = Logic "0" or Logic "1" the part will go into USB mode. In USB mode, the D- and D+ 5Ω switches are ON and the L and R 3Ω audio switches are OFF (high impedance).

When a USB cable from a computer or USB hub is connected at the common connector, the μ processor will sense the present of the 5V VBUS and drive the IN pin voltage high. The ISL54206 part will go into the USB mode. In USB mode, the computer or USB hub transceiver and the MP3 player or cell phone USB transceiver are connected and digital data will be able to be transmitted back and forth.

When the USB cable is disconnected, the μ processor will sense that the 5V VBUS voltage is no longer connected and will drive the IN pin low and put the part back into the Audio or Low Power Mode.

Low Power Mode

If the IN pin = Logic "0" and CTRL pin = Logic "0," the part will be in the Low Power mode. In the Low Power mode, the audio switches and the USB switches are OFF (high impedance). In this state, the device draws typically 1nA of current.

USING THE COMPUTER VBUS VOLTAGE TO DRIVE THE "IN" PIN

External IN Pull-Down Resistor

Rather than using a micro-processor to control the IN logic pin you can directly drive the IN pin using the VBUS voltage from the computer or USB hub. In order to do this you must connected an external resistor from the IN pin to ground.

When a headphone or nothing is connected at the common connector the external pull-down will pull the IN pin low putting the ISL54206 in the Audio mode or Low Power mode depending on the condition of the CTRL pin.

When a USB cable is connected at the common connector the voltage at the IN pin will be driven to 5V and the part will automatically go into the USB mode.

When the USB cable is disconnected from the common connector the voltage at the IN pin will be pulled low by the

pull-down resistor and return to the Audio Mode or Low Power Mode depending on the condition of the CTRL pin.

Note: The voltage at the IN pin can exceed the VDD voltage by as much as 2.55V. This allows the VBUS voltage from a computer or USB hub (4.4V to 5.25V) to drive the IN pin while the V_{DD} voltage is in the range of 2.7V to 3.6V.

External IN Series Resistor

The ISL54206 contains a clamp circuit between IN and VDD. Whenever the IN voltage is greater than the V_{DD} voltage by more than 2.55V, current will flow through this clamp circuitry into the V_{DD} power supply bus.

During normal USB operation, V_{DD} is in the range of 2.7V to 3.6V and IN (VBUS voltage from computer or USB hub) is in the range of 4.4V to 5.25V, the clamp circuit is not active and no current will flow through the clamp into the V_{DD} supply.

In a USB application, the situation can exist where the VBUS voltage from the computer could be applied at the IN pin before the V_{DD} voltage is up to its normal operating voltage range and current will flow through the clamp into the V_{DD} power supply bus. This current could be quite high when V_{DD} is OFF or at 0V and could potentially damage other components connected in the circuit. In the application circuit, a 22k Ω resistor has been put in series with the IN pin to limit the current to a safe level during this situation.

It is recommended that a current limiting resistor in the range of 10k Ω to 50k Ω be connected in series with the IN pin. It will have minimal impact on the logic level at the IN pin during normal USB operation and protect the circuit during the time VBUS is present before VDD is up to its normal operating voltage.

Note: No external resistor is required in applications where the voltage at the IN pin will not exceed V_{DD} by more than 2.55V.

Typical Performance Curves $T_A = +25^\circ\text{C}$, Unless Otherwise Specified

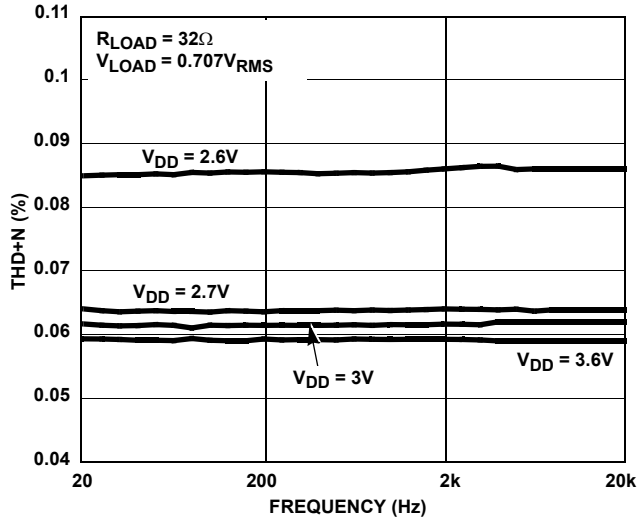

FIGURE 8. THD+N vs SUPPLY VOLTAGE vs FREQUENCY

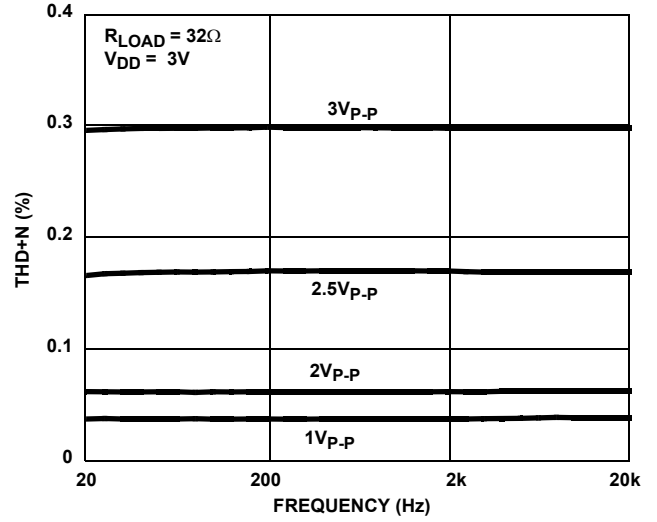

FIGURE 9. THD+N vs SIGNAL LEVELS vs FREQUENCY

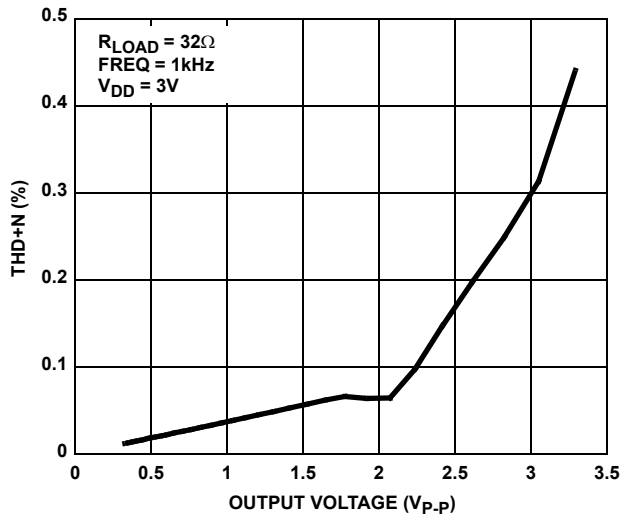

FIGURE 10. THD+N vs OUTPUT VOLTAGE

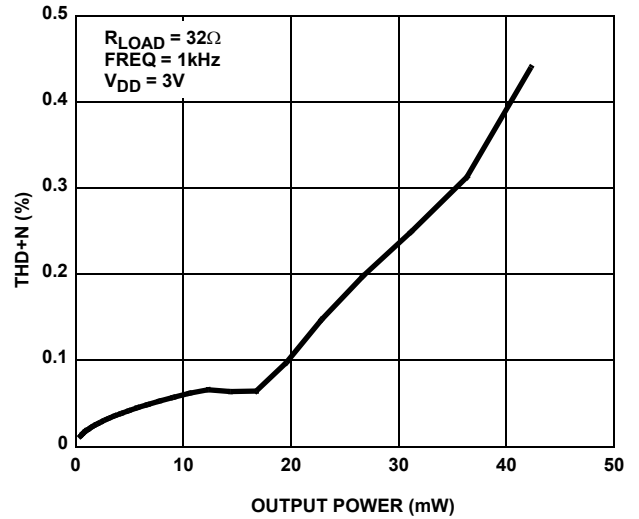

FIGURE 11. THD+N vs OUTPUT POWER

Typical Performance Curves $T_A = +25^\circ\text{C}$, Unless Otherwise Specified (Continued)

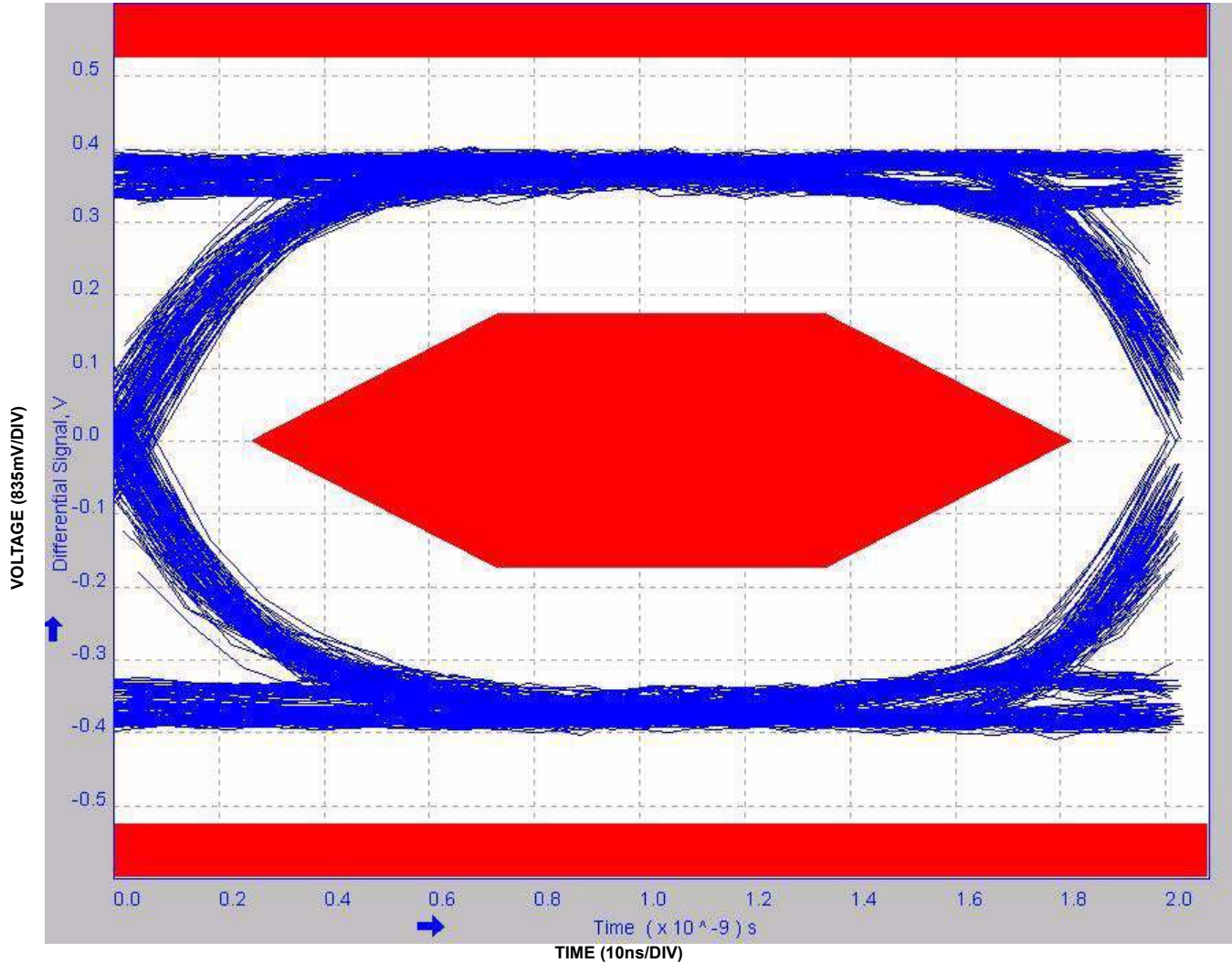

FIGURE 12. EYE PATTERN: 480Mbps WITH SWITCH IN THE SIGNAL PATH

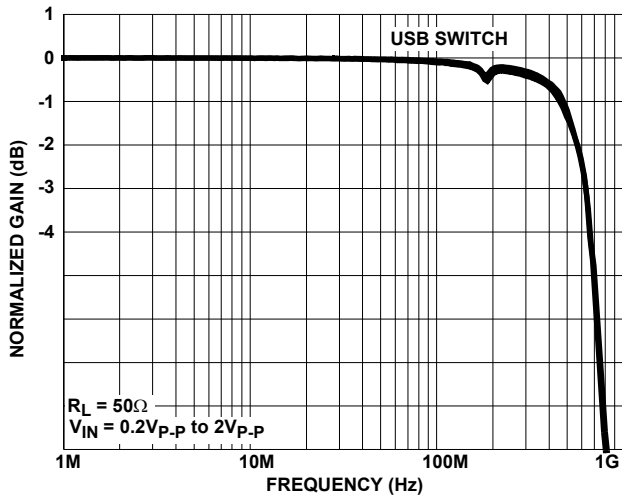

FIGURE 13. FREQUENCY RESPONSE

Die Characteristics

SUBSTRATE POTENTIAL (POWERED UP):

GND (TDFN Paddle Connection: Tie to GND or Float)

TRANSISTOR COUNT:

98

PROCESS:

Submicron CMOS

Ultra Thin Quad Flat No-Lead Plastic Package (UTQFN)

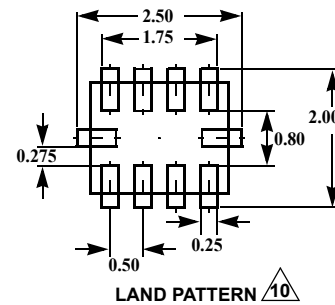
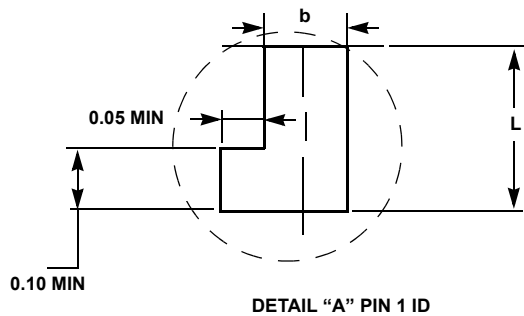
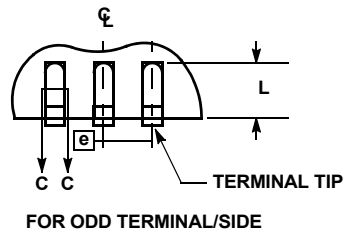
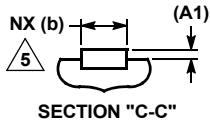
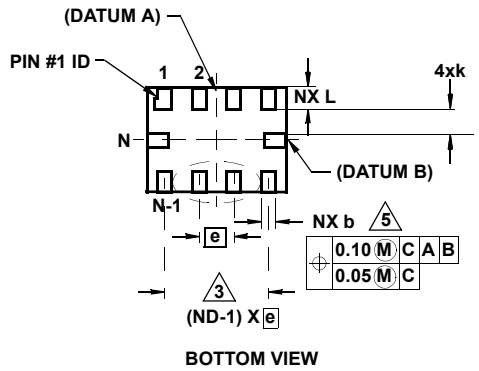
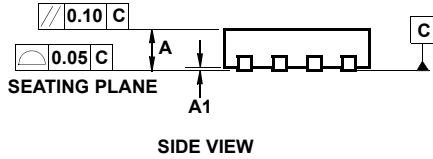
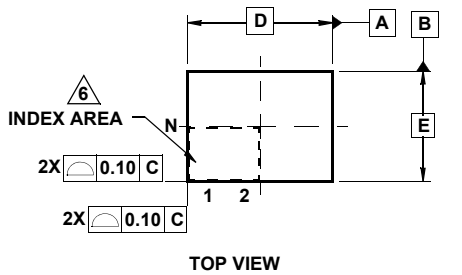

L10.2.1x1.6A

10 LEAD ULTRA THIN QUAD FLAT NO-LEAD PLASTIC PACKAGE

SYMBOL	MILLIMETERS			NOTES
	MIN	NOMINAL	MAX	
A	0.45	0.50	0.55	-
A1	-	-	0.05	-
A3	0.127 REF			-
b	0.15	0.20	0.25	5
D	2.05	2.10	2.15	-
E	1.55	1.60	1.65	-
e	0.50 BSC			-
k	0.20	-	-	-
L	0.35	0.40	0.45	-
N	10			2
Nd	4			3
Ne	1			3
θ	0	-	12	4

Rev. 3 6/06

NOTES:

1. Dimensioning and tolerancing conform to ASME Y14.5-1994.
2. N is the number of terminals.
3. Nd and Ne refer to the number of terminals on D and E side, respectively.
4. All dimensions are in millimeters. Angles are in degrees.
5. Dimension b applies to the metallized terminal and is measured between 0.15mm and 0.30mm from the terminal tip.
6. The configuration of the pin #1 identifier is optional, but must be located within the zone indicated. The pin #1 identifier may be either a mold or mark feature.
7. Maximum package warpage is 0.05mm.
8. Maximum allowable burrs is 0.076mm in all directions.
9. Same as JEDEC MO-255UABD except:
No lead-pull-back, "A" MIN dimension = 0.45 not 0.50mm
"L" MAX dimension = 0.45 not 0.42mm.
10. For additional information, to assist with the PCB Land Pattern Design effort, see Intersil Technical Brief TB389.

Thin Dual Flat No-Lead Plastic Package (TDFN)

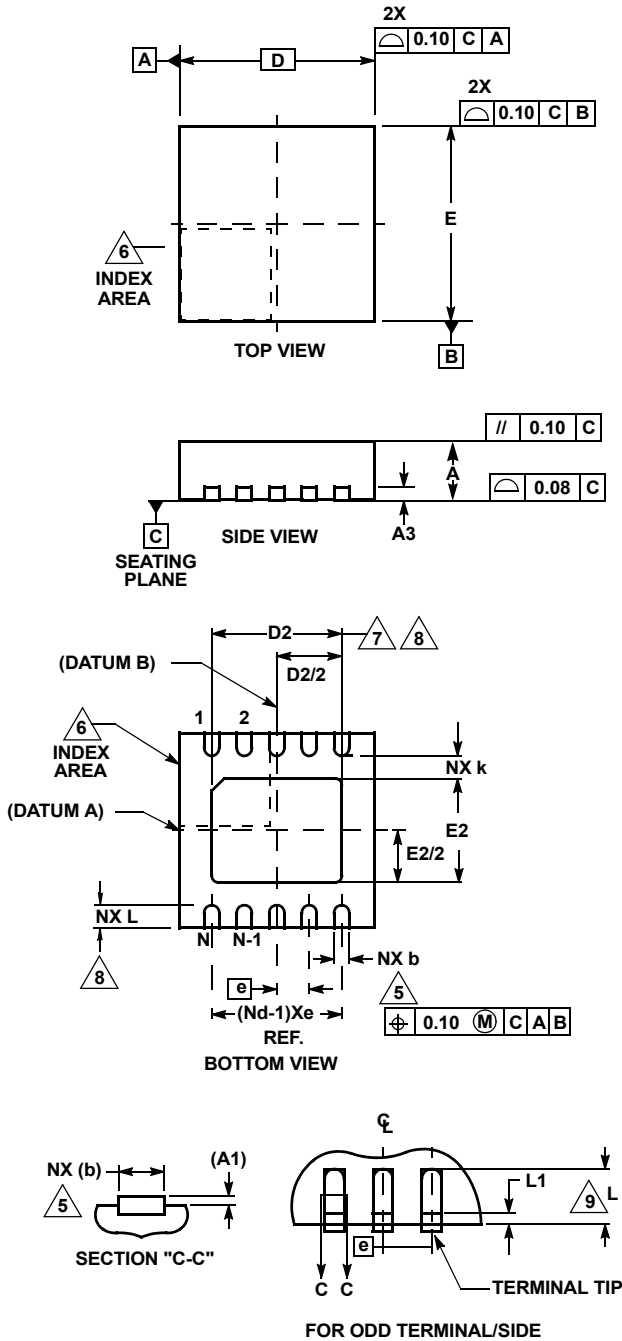

L10.3x3A

10 LEAD THIN DUAL FLAT NO-LEAD PLASTIC PACKAGE

SYMBOL	MILLIMETERS			NOTES
	MIN	NOMINAL	MAX	
A	0.70	0.75	0.80	-
A1	-	-	0.05	-
A3	0.20 REF			-
b	0.20	0.25	0.30	5, 8
D	2.95	3.0	3.05	-
D2	2.25	2.30	2.35	7, 8
E	2.95	3.0	3.05	-
E2	1.45	1.50	1.55	7, 8
e	0.50 BSC			-
k	0.25	-	-	-
L	0.25	0.30	0.35	8
N	10			2
Nd	5			3

Rev. 3 3/06

NOTES:

1. Dimensioning and tolerancing conform to ASME Y14.5-1994.
2. N is the number of terminals.
3. Nd refers to the number of terminals on D.
4. All dimensions are in millimeters. Angles are in degrees.
5. Dimension b applies to the metallized terminal and is measured between 0.15mm and 0.30mm from the terminal tip.
6. The configuration of the pin #1 identifier is optional, but must be located within the zone indicated. The pin #1 identifier may be either a mold or mark feature.
7. Dimensions D2 and E2 are for the exposed pads which provide improved electrical and thermal performance.
8. Nominal dimensions are provided to assist with PCB Land Pattern Design efforts, see Intersil Technical Brief TB389.
9. Compliant to JEDEC MO-229-WEED-3 except for D2 dimensions.

© Copyright Intersil Americas LLC 2006. All Rights Reserved.

All trademarks and registered trademarks are the property of their respective owners.

For additional products, see www.intersil.com/en/products.html

Intersil products are manufactured, assembled and tested utilizing ISO9001 quality systems as noted in the quality certifications found at www.intersil.com/en/support/qualandreliability.html

Intersil products are sold by description only. Intersil may modify the circuit design and/or specifications of products at any time without notice, provided that such modification does not, in Intersil's sole judgment, affect the form, fit or function of the product. Accordingly, the reader is cautioned to verify that datasheets are current before placing orders. Information furnished by Intersil is believed to be accurate and reliable. However, no responsibility is assumed by Intersil or its subsidiaries for its use; nor for any infringements of patents or other rights of third parties which may result from its use. No license is granted by implication or otherwise under any patent or patent rights of Intersil or its subsidiaries.

For information regarding Intersil Corporation and its products, see www.intersil.com