

PRODUCT NO. 95635-XXXX	PUSH-ROD LOCATION		STAND-OFF HEIGHT DIM "L"	DIM "P"	DOUBLE - DECK HEADER 92821-XXX	Ⓑ	Ⓒ	MOUNTING STYLE TO PCB AND PUSH-ROD SIDE
	DECK CLOSEST TO PCB	DECK FARTHEST FROM PCB				EJECT MECHANISM 88644-XXXX	EJECT MECHANISM 94307-XXXX	
000CA	LEFT	RIGHT	0.0	2.8	92821-000	10CA	00CA	
020CA	LEFT	RIGHT	2.0	2.5	92821-040	12CA	00CA	
050CA	LEFT	RIGHT	5.0	2.8	57956-050	15CA	00CA	
100CA	RIGHT	LEFT	0.0	2.8	92821-000	00CA	10CA	
120CA	RIGHT	LEFT	2.0	2.5	92821-040	02CA	10CA	
150CA	RIGHT	LEFT	5.0	2.8	57956-050	05CA	10CA	
200CA	RIGHT	RIGHT	0.0	2.8	92821-000	00CA	00CA	
220CA	RIGHT	RIGHT	2.0	2.5	92821-040	02CA	00CA	
250CA	RIGHT	RIGHT	5.0	2.8	57956-050	05CA	00CA	
300CA	LEFT	LEFT	0.0	2.8	92821-000	10CA	10CA	
320CA	LEFT	LEFT	2.0	2.5	92821-040	12CA	10CA	
350CA	LEFT	LEFT	5.0	2.8	57956-050	15CA	10CA	
000CALF	LEFT	RIGHT	0.0	2.8	92821-000LF	10CA	00CA	
020CALF	LEFT	RIGHT	2.0	2.5	92821-040LF	12CA	00CA	
050CALF	LEFT	RIGHT	5.0	2.8	57956-050LF	15CA	00CA	
100CALF	RIGHT	LEFT	0.0	2.8	92821-000LF	00CA	10CA	
120CALF	RIGHT	LEFT	2.0	2.5	92821-040LF	02CA	10CA	
150CALF	RIGHT	LEFT	5.0	2.8	57956-050LF	05CA	10CA	
200CALF	RIGHT	RIGHT	0.0	2.8	92821-000LF	00CA	00CA	
220CALF	RIGHT	RIGHT	2.0	2.5	92821-040LF	02CA	00CA	
250CALF	RIGHT	RIGHT	5.0	2.8	57956-050LF	05CA	00CA	
300CALF	LEFT	LEFT	0.0	2.8	92821-000LF	10CA	10CA	
320CALF	LEFT	LEFT	2.0	2.5	92821-040LF	12CA	10CA	
350CALF	LEFT	LEFT	5.0	2.8	57956-050LF	15CA	10CA	

mat'l. code		surface <input checked="" type="checkbox"/> ISO 1302 <input checked="" type="checkbox"/> ISO 406 <input type="checkbox"/> ISO 1101		tolerance	projection	product family	
ltr ecn nodr		date		tolerances unless otherwise specified		PCMCIA	
D	V61383	RDS	9/16/96	angle $\frac{1}{2}$	MM	DOUBLE-DECK	
E	V11670	RGD	6/6/01	$0.X \pm 0.3$	scale 1:1	HEADER EJECT ASSY	
F	V20419	LP	3/25/02	$0.XX \pm 0.13$			
G	N05-0052	WB	02/25/05	$0' \pm 2'$	0.XXX ± 0.051		
H	N05-0077	WB	03/17/05	dr	D.SHEAFFER	9/16/96	dwg no
J	ELX-N-007340	ZK	10/25/11	chr	D.BRANN	9/16/96	sheet 1 of 4
K	ELX-N-011443	ZK	04/12/12	appd	D.BRANN	9/16/96	size
sheet index		revision	K	K	K	K	A4
		sheet	1	2	3	4	



PRODUCT NO. 95635-XXXX	PUSH-ROD LOCATION		STAND-OFF HEIGHT DIM "L"	DIM "P"	(A)	(B) CLOSEST TO PCB	(C) FARTHEST FROM PCB	MOUNTING STYLE TO PCB AND PUSH-ROD SIDE
	DECK CLOSEST TO PCB	DECK FARTHEST FROM PCB			DOUBLE - DECK HEADER 92821-XXX	EJECT MECHANISM 88644-XXXX	EJECT MECHANISM 94307-XXXX	
500CA	RIGHT	LEFT	0.0	2.8	92821-500	10CA	00CA	
520CA	RIGHT	LEFT	2.0	2.5	92821-540	12CA	00CA	
550CA	RIGHT	LEFT	5.0	2.8	57956-550	15CA	00CA	
600CA	LEFT	RIGHT	0.0	2.8	92821-500	00CA	10CA	
620CA	LEFT	RIGHT	2.0	2.5	92821-540	02CA	10CA	
650CA	LEFT	RIGHT	5.0	2.8	57956-550	05CA	10CA	
700CA	RIGHT	RIGHT	0.0	2.8	92821-500	10CA	10CA	
700CP	RIGHT	RIGHT	0.0	2.8	92821-500	10CP	10CP	
720CA	RIGHT	RIGHT	2.0	2.5	92821-540	12CA	10CA	
750CA	RIGHT	RIGHT	5.0	2.8	57956-550	15CA	10CA	
800CA	LEFT	LEFT	0.0	2.8	92821-500	00CA	00CA	
820CA	LEFT	LEFT	2.0	2.5	92821-540	02CA	00CA	
850CA	LEFT	LEFT	5.0	2.8	57956-550	05CA	00CA	
500CALF	RIGHT	LEFT	0.0	2.8	92821-500LF	10CA	00CA	
520CALF	RIGHT	LEFT	2.0	2.5	92821-540LF	12CA	00CA	
550CALF	RIGHT	LEFT	5.0	2.8	57956-550LF	15CA	00CA	
600CALF	LEFT	RIGHT	0.0	2.8	92821-500LF	00CA	10CA	
620CALF	LEFT	RIGHT	2.0	2.5	92821-540LF	02CA	10CA	
650CALF	LEFT	RIGHT	5.0	2.8	57956-550LF	05CA	10CA	
700CALF	RIGHT	RIGHT	0.0	2.8	92821-500LF	10CA	10CA	
700CPLF	RIGHT	RIGHT	0.0	2.8	92821-500LF	10CP	10CP	
720CALF	RIGHT	RIGHT	2.0	2.5	92821-540LF	12CA	10CA	
750CALF	RIGHT	RIGHT	5.0	2.8	57956-550LF	15CA	10CA	
800CALF	LEFT	LEFT	0.0	2.8	92821-500LF	00CA	00CA	
820CALF	LEFT	LEFT	2.0	2.5	92821-540LF	02CA	00CA	
850CALF	LEFT	LEFT	5.0	2.8	57956-550LF	05CA	00CA	

NOTES (CONTINUOUS ON SHEET 3):

- EJECT FORCE 3.5kg MAX.
- EJECT TRAVEL - 8.0mm
- MATERIAL
HOUSING: HIGH TEMPERATURE THERMOPLASTIC UL94V-0 BLACK
TERMINAL: COPPER ALLOY
COVER: STAINLESS STEEL
- FINISH - PIN
UNDER PLATING: 1.27µm MIN. Ni
CONTACT AREA: 0.076 µm MIN. GOLD
SOLDER TAIL (TIN LEAD OPTION): 2.5µm MIN Sn-Pb
SOLDER TAIL (LEAD FREE OPTION): 2.5µm MIN PURE TIN

mat'l. code		surface <input checked="" type="checkbox"/> ISO 1302 <input checked="" type="checkbox"/> ISO 406 <input type="checkbox"/> ISO 1101		tolerance		projection		product family	
l t r e c n n o d r		date		tolerances unless otherwise specified				PCMCIA	
k				angle		MM		DOUBLE-DECK HEADER EJECT ASSY	
				0°±2'		scale 1:1		dwg no 95635	
				dr D.SHEAFFER 9/16/96				sheet 2 of 4	
				enr D.BRANN 9/16/96				size A4	
				chr D.BRANN 9/16/96				type Product Customer Drawing	
				appd D.BRANN 9/16/96					
sheet index		revision sheet							

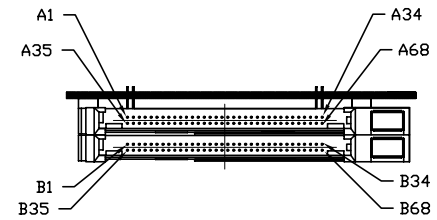
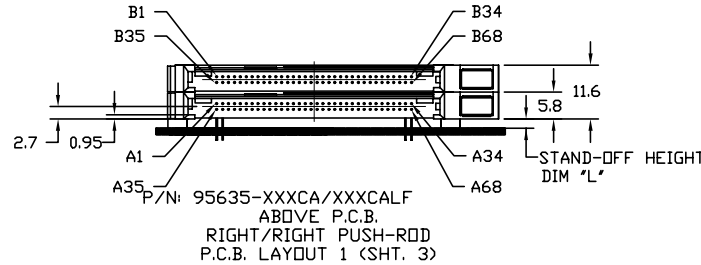
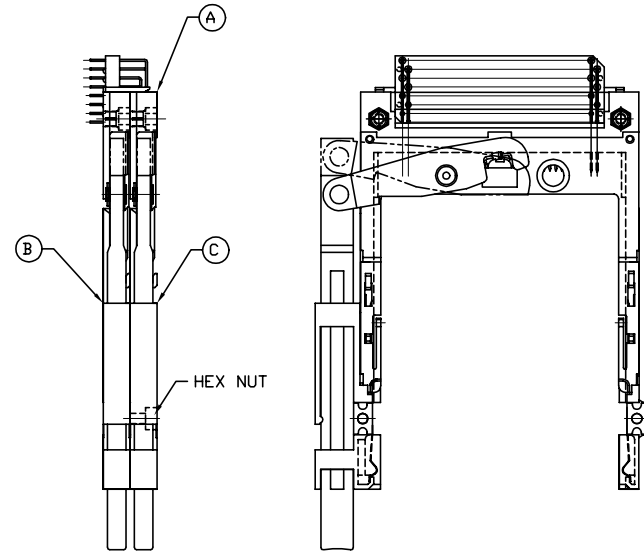
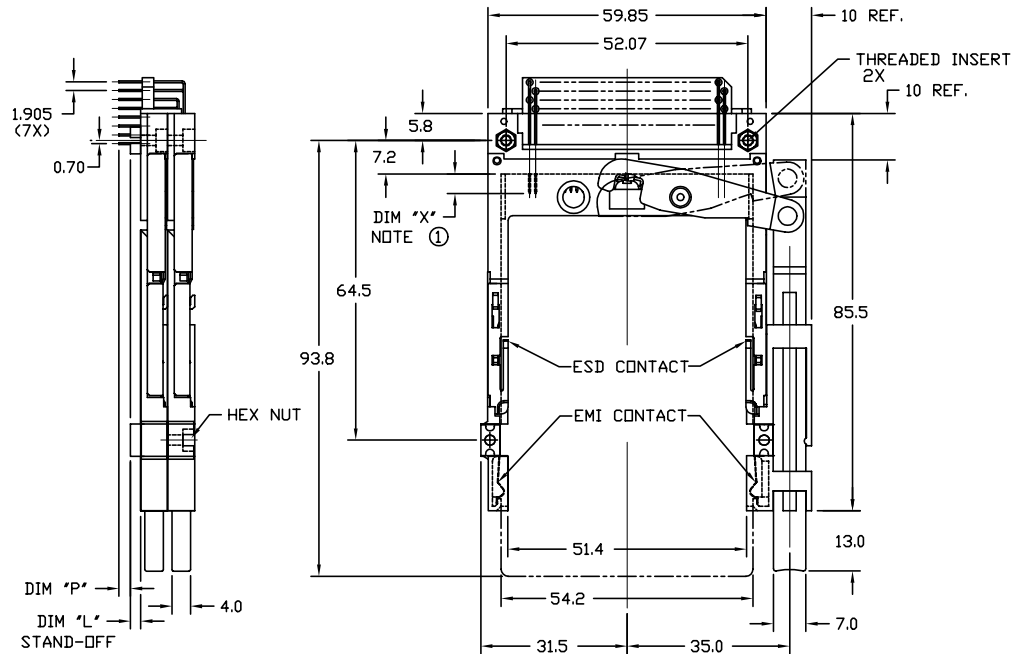

P/N: 95635-XXXCA/XXXCALF
BELOW P.C.B.
RIGHT/RIGHT PUSH-ROD
P.C.B. LAYOUT 2 (SHT. 3)
VIEW ROTATED 180°
PUSH-ROD & DECK ARE
AS VIEWED BY USER

NOTES (CONTINUOUS FROM SHEET 2):

DIM "X"	4.25±0.1	3.5±0.1	5.0±0.1
	PIN NUMBER	OTHERS	36,67

- RECOMMENDED HOLD DOWN - 2mm SCREWS (95121)
RECOMMENDED SCREW TORQUE: 1.0 TO 1.5 MAX in.-lbs. (1.2-1.7 cm.-kgs).
- IF LEAD FREE P/N, THE HOUSING WILL WITHSTAND EXPOSURE TO 260°C PEAK TEMPERATURE FOR 10 SECONDS IN A WAVE SOLDER APPLICATION WITH A 1.00MM MINIMUM THICK CIRCUIT BOARD.
- LEAD FREE PRODUCT MEETS EUROPEAN UNION DIRECTIVES AND OTHER COUNTRY REGULATIONS AS DISCRIBLED IN GS-22-008
- IF LEAD FREE P/N, PACKAGING MEETS GS-14-920 SPECIFICATION
- PRODUCT SPEC: 110-263

mat'l. code	surface	tolerance	projection	product family
	ISO 1302	ISO 406 ISO 1101		PCMCIA
l t r e c n n o d r	date	tolerances unless otherwise specified	MM	DOUBLE-DECK HEADER EJECT ASSY
K		0.X±0.3	scale 1:1	dwg no
		0.XX±0.13		sheet 3 of 4
		0.XXX±0.051		size
dr	D.SHAFFER	9/16/96		95635
enr	D.BRANN	9/16/96		A4
chr	D.BRANN	9/16/96		
appd	D.BRANN	9/16/96		
sheet index	revision sheet			type Product Customer Drawing

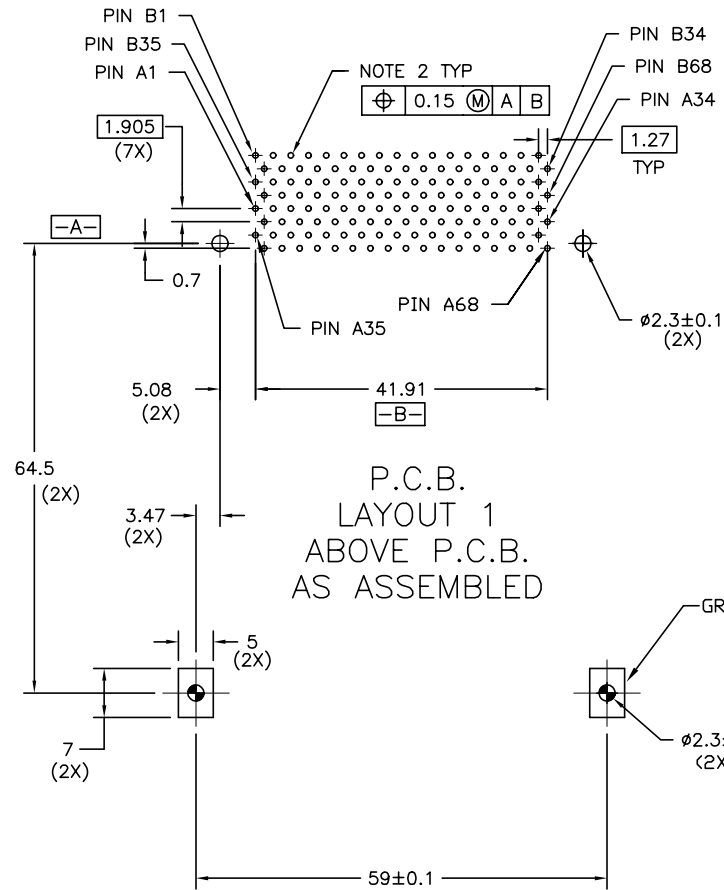

P.C.B. LAYOUT 1 ABOVE P.C.B. AS ASSEMBLED

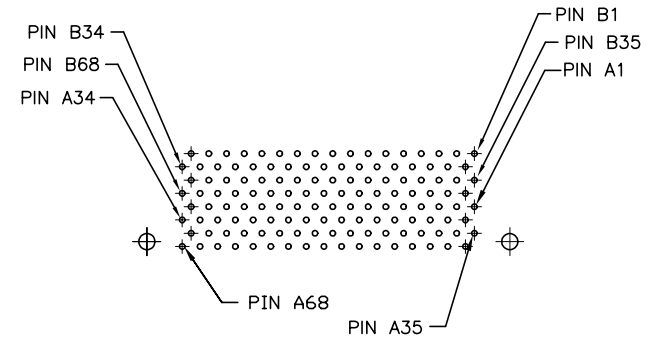

P.C.B. LAYOUT 2 BELOW P.C.B. AS ASSEMBLED

NOTES:

1. ALL TOLERANCES ± 0.15 UNLESS NOTED.
2. RECOMMENDED DIAMETER IS $\phi 1.0$ FOR PROCESSES USING PASTE REFLOW. HOLE MAY BE AS SMALL AS $\phi 0.79$
3. BOARD VIEW FROM CONNECTOR MOUNTED SIDE TOP OF BOARD IN APPLICATION

mat'l. code		surface <input checked="" type="checkbox"/> ISO 1302 <input checked="" type="checkbox"/> ISO 406 <input type="checkbox"/> ISO 1101		tolerance	projection	product family	
ltr ecn nodr		date		tolerances unless otherwise specified		PCMCIA	
k		angle		MM		DOUBLE-DECK	
		0°±2'		0.XX±0.13		HEADER EJECT ASSY	
				0.XXX±0.051		scale 1:1	
dr		D.SHEAFFER		9/16/96		dwg no	
enr		D.BRANN		9/16/96		sheet 4 of 4	
chr		D.BRANN		9/16/96		size	
appd		D.BRANN		9/16/96		A4	
sheet index		revision sheet		type		Product Customer Drawing	

