

THIS DRAWING IS UNPUBLISHED. RELEASED FOR PUBLICATION
 © COPYRIGHT 2005 By - ALL RIGHTS RESERVED.

LOC	DIST	REVISIONS					
GP	00	P	LTR	DESCRIPTION	DATE	DWN	APVD
		Z		REVISED PER ECO-14-011808	09AUG2014	AP	SB

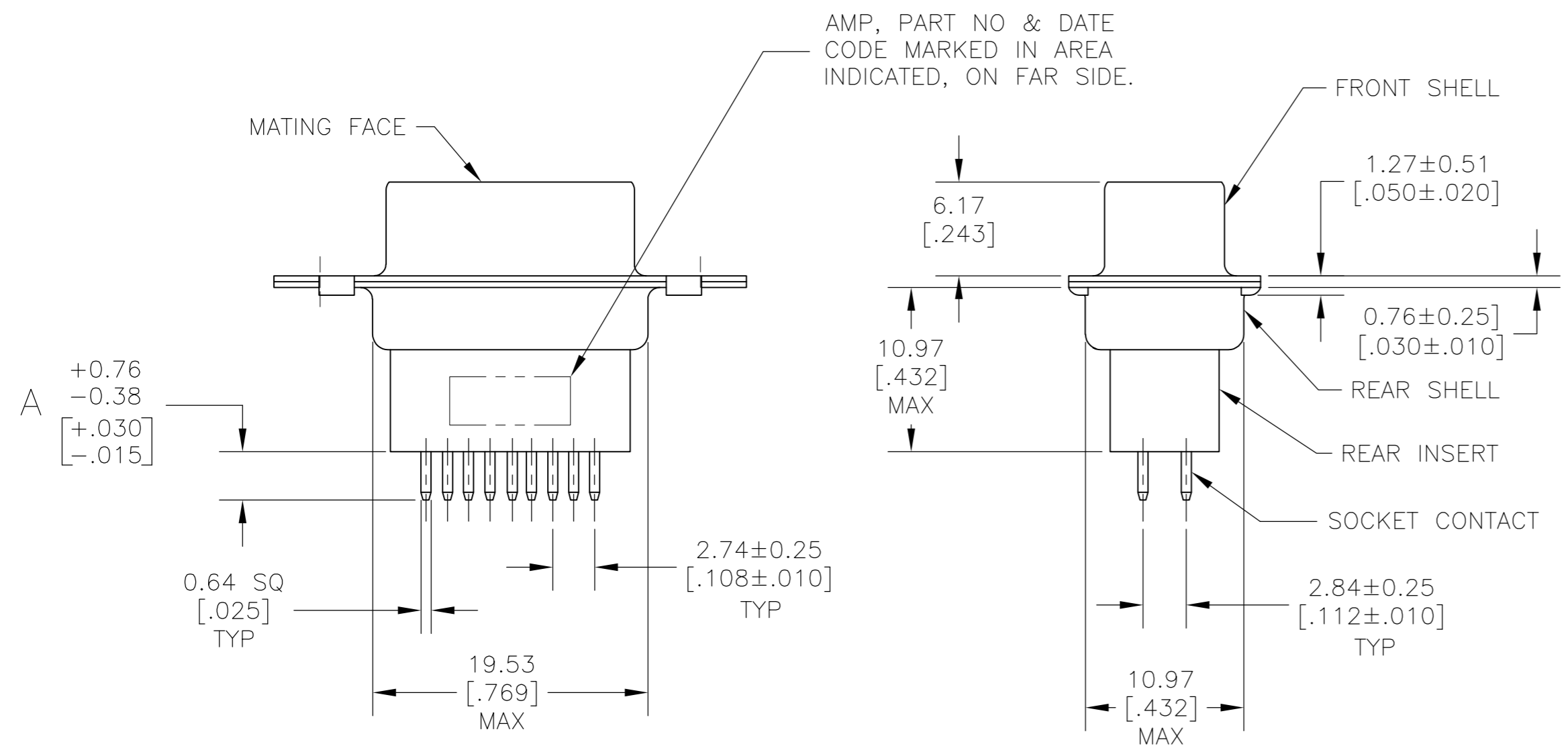
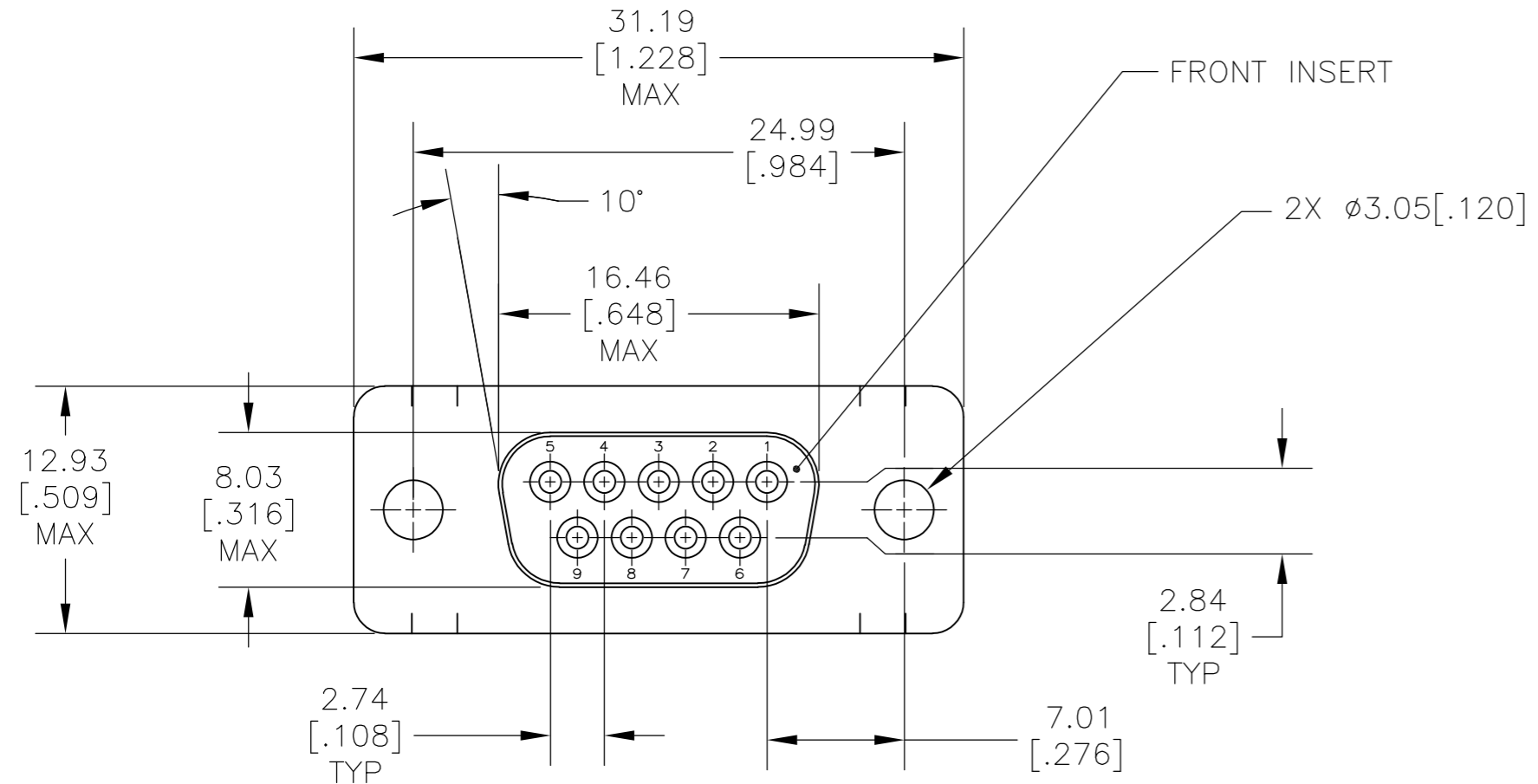

- 1 MOLDED PARTS: GLASS-FILLED PBT OR GLASS-FILLED NYLON, UL94V-0 RATED.
COLOR: BLACK
SHELLS: CARBON STEEL.
CONTACTS: PHOS BRONZE.
- 2 SHELLS: 5.08µm [.000200] MIN ZINC WITH YELLOW CHROMATE COATING.
CONTACTS: GOLD FLASH PLATED FOR LENGTH OF 3.81 [.150] MIN FROM MATING END,
2.54µm [.000100] MIN TIN-LEAD ON SOLDER END, BOTH OVER
1.27µm [.000050] MIN NICKEL.
- 3. NOTE DELETED.
- 4. NOTE DELETED.
- 5. NOTE DELETED.
- 6. NOTE DELETED.
- 7 SHELLS: 5.08µm [.000200] MIN ZINC WITH YELLOW CHROMATE COATING.
CONTACTS: GOLD PLATED FOR LENGTH OF 3.81 [.150] MIN FROM MATING END,
0.76µm [.000030] MIN GOLD IN MATED AREA,
2.54µm [.000100] MIN TIN-LEAD ON SOLDER END, BOTH OVER
1.27µm [.000050] MIN NICKEL.
OR
GOLD FLASH OVER PALLADIUM-NICKEL PLATED FOR LENGTH OF
3.81 [.150] MIN FROM MATING END,
0.76µm [.000030] MIN TOTAL IN MATED AREA,
2.54µm [.000100] MIN TIN-LEAD ON SOLDER END, BOTH OVER
1.27µm [.000050] MIN NICKEL.

OBSOLETE	-	-	205734-9
SUPSD BY 205734-7	2	4.78 [.188]	205734-8
	7	4.78 [.188]	205734-7
SUPSD BY 205734-5	-	-	205734-6
	7	16.54 [.651]	205734-5
	2	10.85 [.427]	205734-4
SUPSD BY 205734-5	7	10.85 [.427]	205734-3
SUPSD BY 205734-1	2	3.18 [.125]	205734-2
	7	3.18 [.125]	205734-1
	CONTACT FINISH	A	PART NUMBER

THIS DRAWING IS A CONTROLLED DOCUMENT.

DWN J. POLIGNONE 01FEB07	TE Connectivity RECEPTACLE ASSEMBLY, SIZE 1, 9 POSN, VERTICAL, AMPLIMITE HDP
CHK E. BRIANT 01FEB07	
APVD E. BRIANT 01FEB07	
PRODUCT SPEC 108-40025	
MATERIAL 1	NAME 114-40013 APPLICATION SPEC 114-40013 WEIGHT - CUSTOMER DRAWING
DIMENSIONS: mm [INCHES] TOLERANCES UNLESS OTHERWISE SPECIFIED: 0 PLC ± - 1 PLC ± - 2 PLC ± - 3 PLC ± .005 4 PLC ± - ANGLES ± - FINISH 2 7	SIZE A2 CAGE CODE 00779 DRAWING NO C=205734 RESTRICTED TO - SCALE NTS SHEET 1 of 1 REV Z