

THE REVISION STATUS OF ALL SHEETS OF THIS DRAWING IS THE SAME AS SHEET 1

LTR	DESCRIPTION	DATE	BY
A	Released	3/4/96	JCL
B	Updated Sketch	6/1/06	JCL

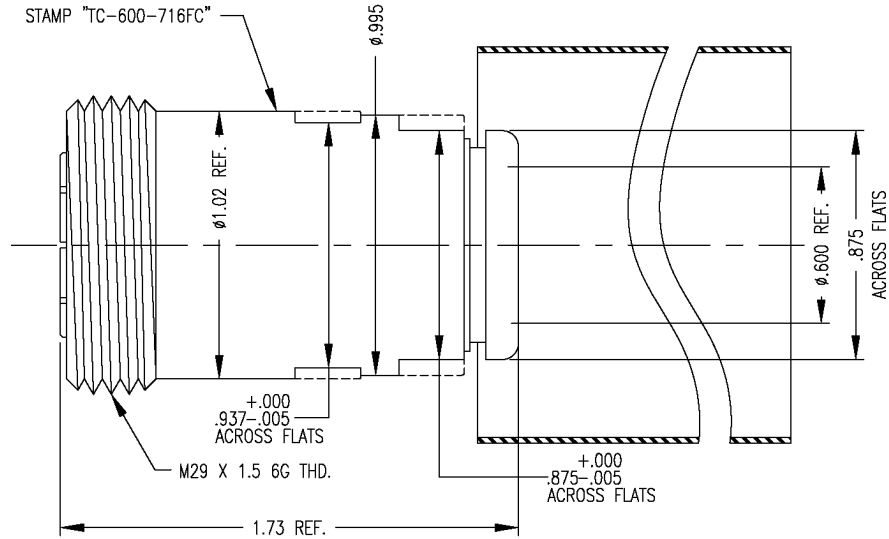

**I. MATERIALS & FINISHES**

- center contact: Silver Plated Beryllium Copper
- outer contact: Silver Plated Brass
- body: Silver Plated Brass
- crimp sleeve: Silver Plated Copper
- dielectric: Teflon® PTFE
- gasket: Silicone Rubber
- shrink sleeve: Adhesive Lined Polyolefin
- attachment: braid clamp

**II. ELECTRICAL PROPERTIES**

- impedance: 50 ohms
- working voltage: 2700 vrms (max)
- vswr: 1.25:1 (max) up to 2.5 GHz
- insertion loss: 0.1 x √Fghz

Unless otherwise specified, dimensions are in inches. Tolerances are applicable when specified.

These drawings and specifications contain proprietary information which is the property of Times Microwave Systems.

Approvals		
Drawn	JCL	3/4/96

**TIMES MICROWAVE SYSTEMS**  
 Wallingford, CT 06492  
 (203) 949-8400; (203) 949-8423.Fax  
 www.timesmicrowave.com

**TC-600-716FC**  
 7/16 DIN female (plug)  
 for LMR-600 Cable

Size A	CAGE CODE <b>68999</b>	Drawing No.: <b>3190-375</b>
--------	---------------------------	---------------------------------

Scale: NA	Rev. (A)	Sheet: 1 of 1
-----------	----------	---------------