

REVISIONS					
P	LTR	DESCRIPTION	DATE	DMN	APVD
U		REVISED PER ECO-19-002868	5-2-19	CT	RL

- THIS PLUG WILL MATE WITH ANY 24C7, SIZE 5 RECEPTACLE IN AMPLIMITE SERIES.
- MAXIMUM WIRE INSULATION TO BE USED WITH THIS PLUG IS $\phi.068$.
- THIS CONNECTOR ACCEPTS (7) POWER 8, OR COAX PIN CONTACTS IN POSITIONS A1 THRU A7, PURCHASED SEPARATELY.
- THIS CONNECTOR ACCEPTS SIZE 20 PIN SIGNAL CONTACTS IN POSITIONS 1 THRU 17.
- INSERTION/EXTRACTION TOOL USED FOR SIZE 20 PIN SIGNAL CONTACTS IS 91067-2.
- FINISH: CADMIUM PLATED PER QQ-P-416.
- FINISH: TIN PER ASTM-B-545, .000400 MIN THK OVER COPPER PER AMS2418, .000050 MIN THK.
- FINISH: GOLD PLATED PER MIL-G-45204 TYPE II, GRADE C, CLASS 1 OVER COPPER PER MIL-C-14550, CLASS IV.
- STEEL PER ASTM-A-109.
- BRASS PER MIL-C-50 AND ASTM-B-36 UNS NO. C26000.
- INK STAMP WESTINGHOUSE PART NO: 97942-645A9356H04, FAR SIDE.
- UL/CSA DESIGNATION STAMPED IN THIS AREA.
- FINISH: ZINC PLATE PER ASTM-B-633, .000200-.000400 THK WITH SUPPLEMENTARY CHROMATE (Cr3+)

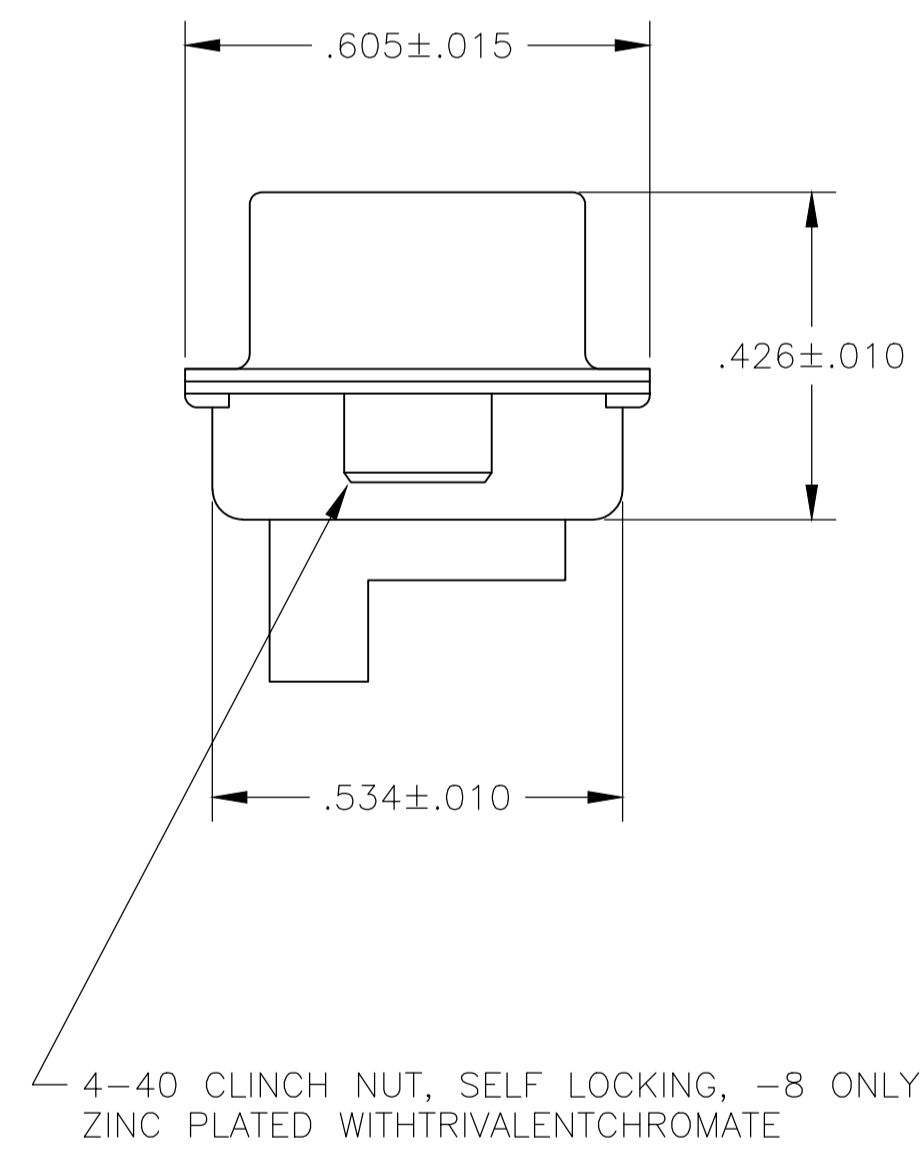
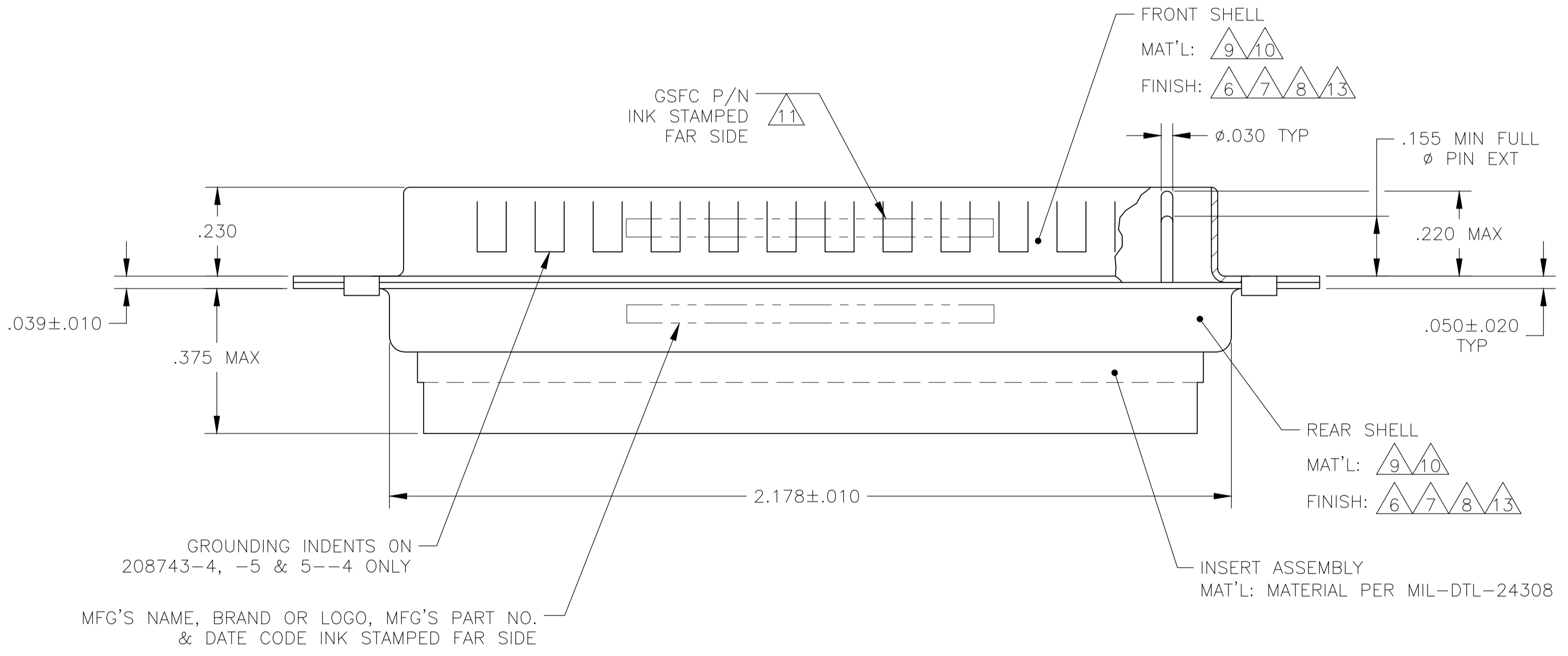
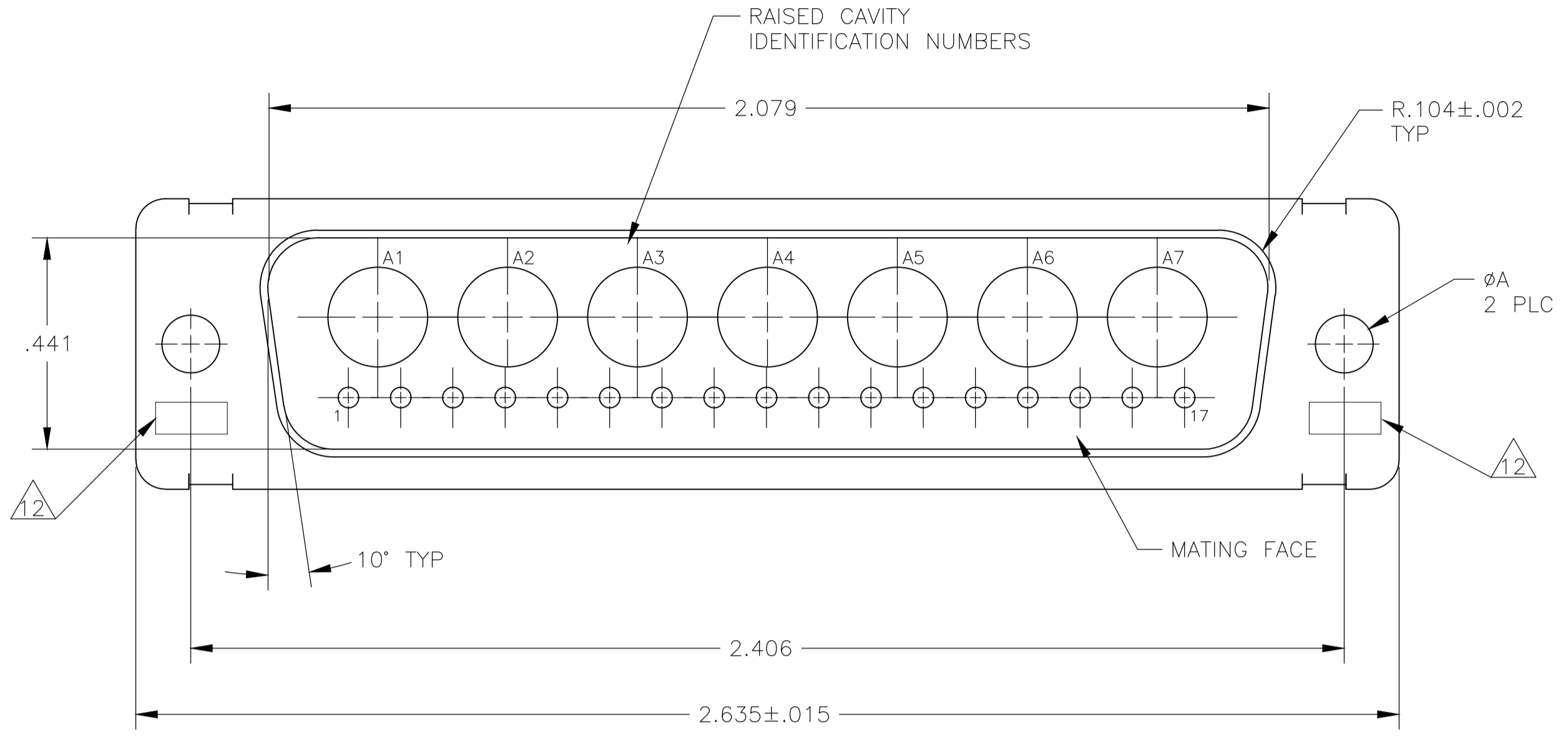

9/7	.120	-	5-208743-4
9/13	.120	-	5-208743-1
9/7	-	-	208743-8
9/7	.120	-	208743-7
8/10	.154	311P405-22S-B-15	208743-6
9/7	.120	-	208743-5
7/9	.120	-	208743-4
6/9/11	.120	-	208743-3
8/10	.120	311P405-22S-B-12	208743-2
6/9	.120	-	208743-1
REMARKS	φA	GSFC P/N	MFG'S PART NO.

GROUNDING INDENTS ON 208743-4, -5 & 5--4 ONLY
 MFG'S NAME, BRAND OR LOGO, MFG'S PART NO. & DATE CODE INK STAMPED FAR SIDE

THIS DRAWING IS A CONTROLLED DOCUMENT. **STE** TE Connectivity Ltd.

DIMENSIONS: INCHES	TOLERANCES UNLESS OTHERWISE SPECIFIED:	0 PLC ± -	1 PLC ± -	2 PLC ± -	3 PLC ± .005(0.13)	4 PLC ± ± 0'.30'	ANGLES ± ± 0'.30'	APPROVED: MANJUNATH G.M. 27-May-15	CHARLES THOMAS 27-May-15	NAME: CHARLES THOMAS	PRODUCT SPEC	APPLICATION SPEC	SIZE: A1	CAGE CODE: 000779	DRAWING NO: 208743	RESTRICTED TO:
MATERIAL: -	FINISH: -	WEIGHT: 0.000000	CUSTOMER DRAWING		SCALE: 4:1	SHEET: 1 of 1	REV: U									