

PART NUMBER	REV	FIRST USED
567716 -1	A	854400-1

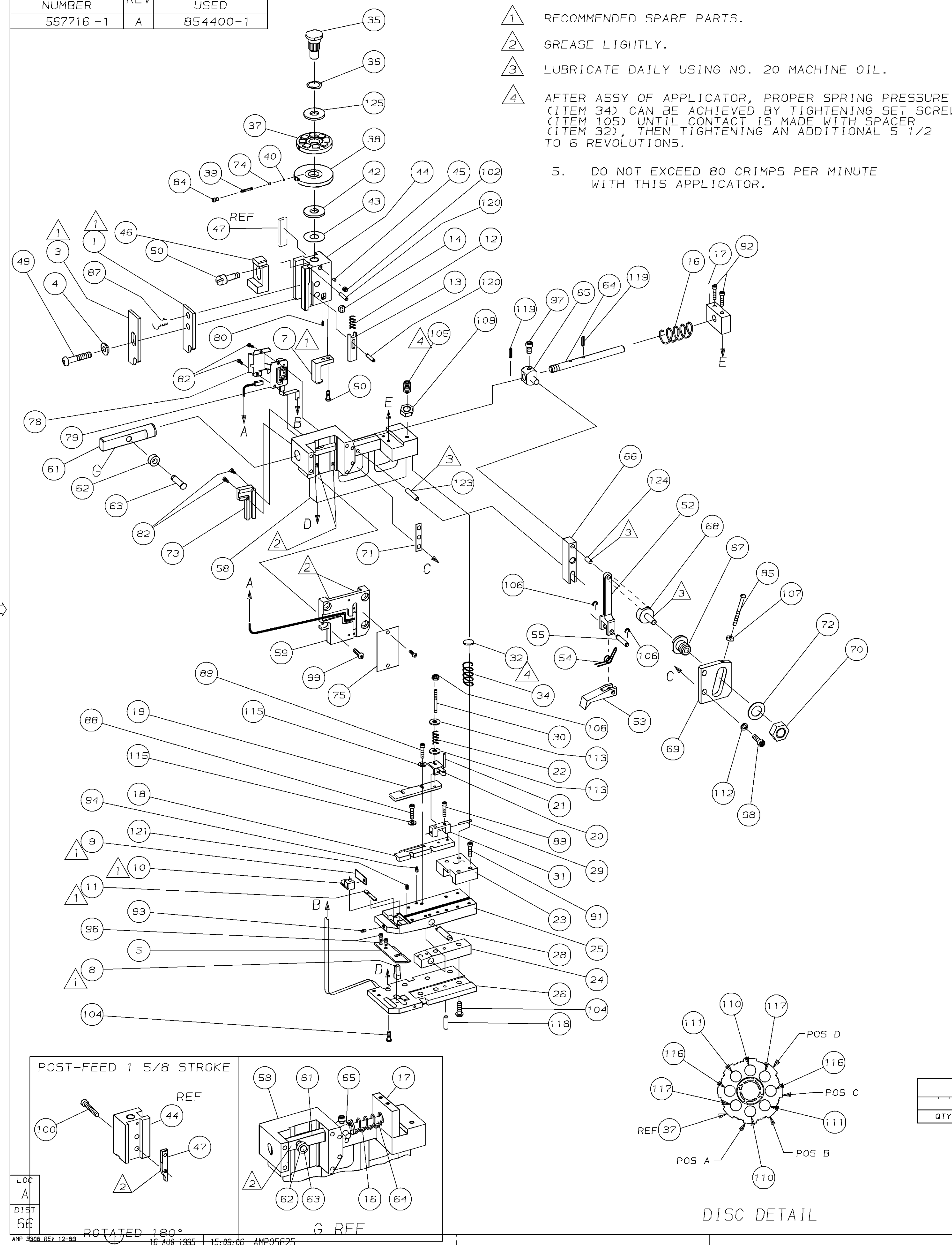

TERMINAL NAME:		.205 SERIES FLAG FASTON	
42234			
60195			
62354			
TERM APPL SPEC 114-207B			

CRIMPING DATA			
PAD LTR	CRIMP HEIGHT	WIRE SIZE	
A	.065	14	
B	.061	16	
C	.058	18	
D	.056	20	
CRIMP	SIZE	TYPE	RANGE
WIRE	.140	TAB LOCK	20-14
INSUL	.140	0	.110-.170
FEED	APPL INST	SET UP GAGE	LAYOUT
.650	AI 8031	-	-
WIRE STRIP LENGTH -			
-1	LEADMAKER	MECH-POST FEED	

REF APPLICATOR 687391-1					
1	-	A	22594-8	NUT, HEX	70
1	-	B	240628-1	PLATE, ADJ	69
1	-	B	240626-1	SHAFT, PIVOT	68
1	-	B	240633-1	BUSHING	67
1	-	A	240630-1	LEVER, INTERMEDIATE	66
1	-	B	240629-1	BLOCK, PIVOT	65
1	-	A	240632-2	SCR, ADJ	64
1	-	B	240659-3	PIN, CAM ROLLER	63
1	-	B	240658-1	ROLLER, CAM	62
1	-	B	240631-1	ROD, FEED	61
					60
1	-	C	768623-1	MODIFIED CAP ASSEMBLY	59
1	-	C	768680-1	HOUSING, MODIFIED	58
					57
					56
1	-	B	240624-1	PIN, FEED FINGER	55
1	-	B	691499-1	SPRING, FEED FINGER	54
1	-	B	454568-1	FINGER, FEED	53
1	-	B	240634-1	LEVER, TERMINAL	52
					51
1	-	A	22353-8	SCREW, SHOULDER	50
1	-	A	3-21002-5	BOLT, CRIMPER	49
					48
1	-	B	238015-1	CAM, POST-FEED 1 5/8 ST	47
1	-	A	690578-1	BLOCK, INSULATION ADJUST	46
1	-	A	690191-1	PLUG, NYLON	45
1	-	C	856807-1	RAM, SPECIAL	44
1	-	A	690125-1	WASHER, LAMINATED	43
1	-	A	1-690124-1	WASHER, RAM	42
					41
1	-	A	23241-6	BALL, STEEL	40
1	-	A	690170-1	SPRING, COMPRESSION	39
1	-	C	690142-1	DISC, INSULATION	38
1	-	D	354777-1	DISC, WIRE, PLASTIC	37
1	-	B	22480-5	WASHER, SPRING	36
1	-	B	690212-1	POST, RAM	35
1	-	A	3-23846-5	SPRING, HINGE BAR	34
					33
1	-	A	690573-1	SPACER, SPRING	32
1	-	C	454569-1	MOUNT, DRAG	31
1	-	A	1-22354-8	STUD, DRAG	30
1	-	A	21030-2	PIN, MOUNT, DRAG	29
1	-	B	690582-1	PIN, HINGE	28
					27
1	-	D	768624-1	BASE PLATE ASSEMBLY	26
1	-	B	856801-1	HINGE BAR, REVISED	25
1	-	B	690571-1	BLOCK, STABILIZER	24
1	-	C	690585-1	BLOCK, PRESSURE	23
1	-	A	8-22282-6	SPRING, DRAG	22
1	-	A	21030-6	LEVER, DRAG	21
1	-	A	454570-1	DRAG, STOCK	20
1	-	C	454573-1	GUIDE, STRIP (REAR)	19
1	-	C	454571-2	GUIDE, STRIP (FRONT)	18
1	-	A	458361-1	GUIDE, FEED ROD	17
1	-	A	4-22284-9	SPRING, FEED RETURN	16
					15
1	-	B	853498-1	MAGNET ASSY	14
1	-	C	692134-5	POSITIONER, TERMINAL	13
1	-	A	5-22280-5	SPRING, TERM. POSITIONER	12
1	-	B	454712-4	PLATE, REAR SHEAR	11
1	-	C	454578-1	ANVIL INSERT	10
1	-	B	690569-2	PLATE, FRONT SHEAR	9
1	-	B	856804-1	ANVIL	8
1	-	B	454575-3	BLADE, SLUG	7
					6
1	-	B	856802-1	PLATE, ANVIL RETAINING	5
1	-	B	690574-1	SPACER, TUBULAR INSUL CRIMPER	4
1	-	C	690715-1	CRIMPER, INSULATION	3
					2
1	-	C	690716-3	CRIMPER, WIRE	1

1	-	A	986950-1	WASHER, FLAT PRECISION	125
1	-	A	1-21030-2	PIN, DOWEL (Ø.187X.62)	124
1	-	A	1-21030-6	PIN, DOWEL (Ø.187X1.25)	123
					122
2	-	A	3-21028-2	PIN, SLOTTED SPRING (Ø.094X.25)	121
2	-	A	4-21028-9	PIN, SLOTTED SPRING (Ø.125X.38)	120
2	-	A	5-21028-1	PIN, SLOTTED SPRING (Ø.125X.50)	119
1	-	A	21029-5	PIN, SLOTTED SPRING (Ø.188X.75)	118
2	-	A	1-354779-0	PIN, WIRE DISC (.3040)D	117
2	-	A	354779-8	PIN, WIRE DISC (.3030)C	116
4	-	A	21024-4	WASHER, LOCK (#8)	115
					114
2	-	A	21899-2	WASHER, FLAT (#10)	113
2	-	A	21024-5	WASHER, LOCK (#10)	112
2	-	A	354779-4	PIN, WIRE DISC (.3010)B	111
2	-	A	9-354778-1	PIN, WIRE DISC (.2950)A	110
1	-	A	1-22202-7	NUT, HEX (5/16-24)	109
1	-	A	21022-3	NUT, HEX (LOCKING) (10-32)	108
1	-	A	21018-5	NUT, HEX (6-32)	107
2	-	A	21045-3	RING, RET "C" (Ø.187)FD PIN	106
1	-	A	8-21007-5	SCREW, SKT SET (5/16-24x.75)	105
7	-	A	2-22733-8	SCREW, BHC (1/4-20X.63)	104
					103
1	-	A	21009-2	SCREW, SKT SET (1/4-20x.25)	102
					101
1	-	A	3-21000-9	SCREW, SHC (10-32X1.00)	100
4	-	A	3-21000-8	SCREW, SHC (10-32X.88)	99
2	-	A	3-21000-6	SCREW, SHC (10-32X.62)	98
1	-	A	3-21000-4	SCREW, SHC (10-32X.38)	97
2	-	A	7-21000-6	SCREW, SHC (10-32X.31)	96
					95
2	-	A	4-21006-0	SCREW, SKT SET (8-32X.25)	94
1	-	A	21061-9	SCREW, SKT SET (8-32X.25)	93
2	-	A	3-21000-0	SCREW, SHC (8-32X.88)	92
4	-	A	2-21000-9	SCREW, SHC (8-32X.75)	91
2	-	A	1-23030-1	SCREW, SHC (NYLOK) (8-32X.62)	90
4	-	A	2-21000-8	SCREW, SHC (8-32X.62)	89
2	-	A	2-21000-7	SCREW, SHC (8-32X.50)	88
1	-	A	2-21002-1	SCREW, SBHC (8-32X.38)	87
					86
1	-	A	6-23715-5	SCR, PAN HD (6-32x1.50)FEED ADJ	85
1	-	A	23030-1	SCREW, SHC (NYLOK) (6-32X.25)	84
					83
4	-	A	1-21002-5	SCREW, SBHC (4-40X.50)	82
					81
1	-	A	2-21006-1	SCREW, SOC SET (4-40X.25)	80
1	-	C	856822-1	PCB ASSY	79
1	-	C	856825-1	COVER, PCB	78
					77
					76
1	-	B	461264-1	PLATE, IDENTIFICATION	75
1	-	A	690603-1	SPRING, ASSIST	74
1	-	B	314867-1	COVER, FLAT FLEX	73
1	-	A	458109-1	WASHER, SPECIAL	72
1	-	A	690517-1	SPACER	71

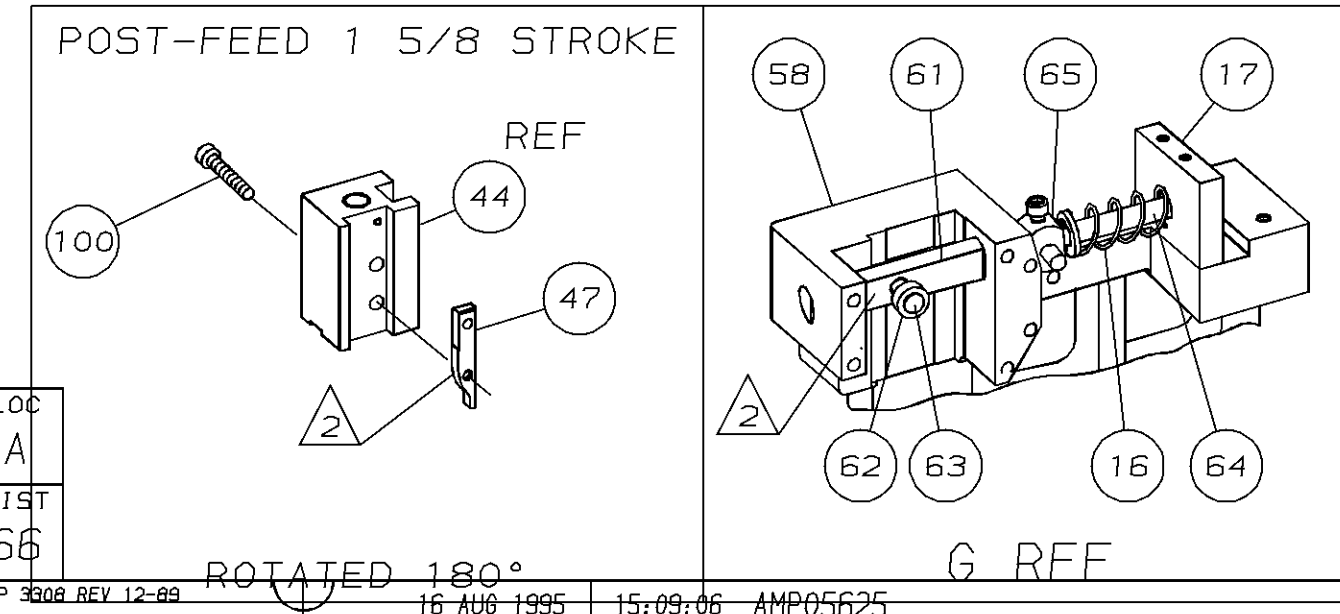

THIS DRAWING IS A CONTROLLED DOCUMENT FOR AMP INCORPORATED. IT IS SUBJECT TO CHANGE AND THE CONTROLLING ENGINEERING ORGANIZATION SHOULD BE CONTACTED FOR THE LATEST REVISION.

THIS INFORMATION IS CONFIDENTIAL AND IS DISCLOSED TO YOU ON CONDITION THAT NO FURTHER DISCLOSURE IS MADE BY YOU TO OTHER THAN AMP PERSONNEL WITHOUT WRITTEN AUTHORIZATION FROM AMP INCORPORATED, HARRISBURG, PA.

567716