

# MIL-STD-1553 Bus Couplers

## Product Overview

The MIL-STD-1553 specification supports the connection of multiple devices through a redundant, deterministic, serial data bus. These devices are connected to the bus through tributaries called stubs. Stubs for Remote Terminals, Bus Controllers, or Bus Monitors, are connected to the bus through coupling boxes that provide single or multiple stub connections.

These couplers provide the necessary shielding, isolation resistors, and transformer interface. The data bus passes through the coupler by connecting to two connectors. Each coupler has one or more stubs (Trompeter offers up to eight stub configurations). The stub connections are left unterminated when not in use. If the coupler resides at the end of the bus, an external termination resistor is connected to properly terminate the bus.

In addition to the bus couplers, Trompeter offers all of the needed terminators, RFI Caps, cable and cable assemblies required for a MIL-STD-1553 data bus link.



### Terminators



### Bus Couplers



### Bulk Cable



### Connectors

### Cable Assemblies



### Adapters



### RFI Caps



# MIL-STD-1553 Bus Couplers

## Features

- Meet the requirements of MIL-STD-1553B
- Lead free versions available



## Trompeter Bus Couplers

Part Number	Stub Count	Interface	Termination Type	Lead Free
TEBC-1001	1	TRB (BJ770)	Unterminated	No
TEBC-1001-LF	1	TRB (BJ770)	Unterminated	Yes
TEBC-1002	2	TRB (BJ770)	Unterminated	No
TEBC-1002-LF	2	TRB (BJ770)	Unterminated	Yes
TEBC-1003	3	TRB (BJ770)	Unterminated	No
TEBC-1003-LF	3	TRB (BJ770)	Unterminated	Yes
TEBC-1004	4	TRB (BJ770)	Unterminated	No
TEBC-1004-LF	4	TRB (BJ770)	Unterminated	Yes
TEBC-1005	5	TRB (BJ770)	Unterminated	No
TEBC-1005-LF	5	TRB (BJ770)	Unterminated	Yes
TEBC-1008	8	TRB (BJ770)	Unterminated	No
TEBC-1008-LF	8	TRB (BJ770)	Unterminated	Yes

# MIL-STD-1553 Bus Couplers

## Dimensions

**TEBC-1001** 1 Stub Coupler

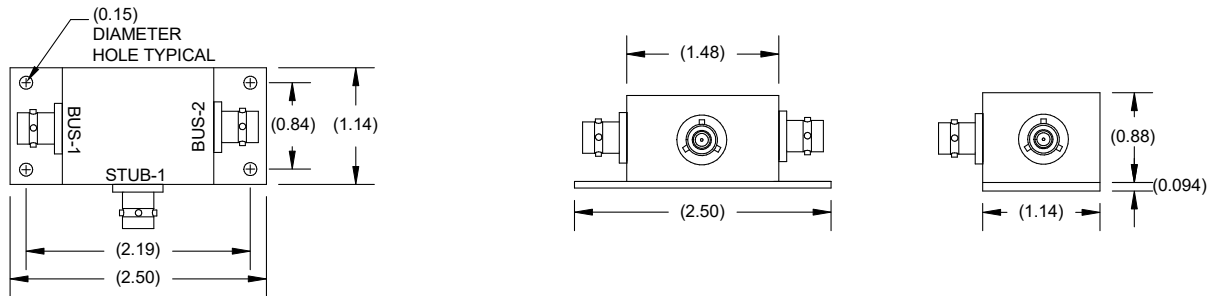

**TEBC-1002** 2 Stub Coupler

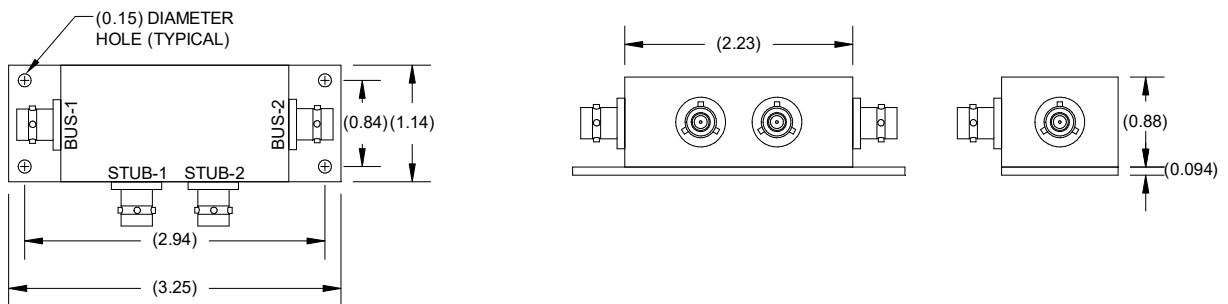

**TEBC-1003** 3 Stub Coupler

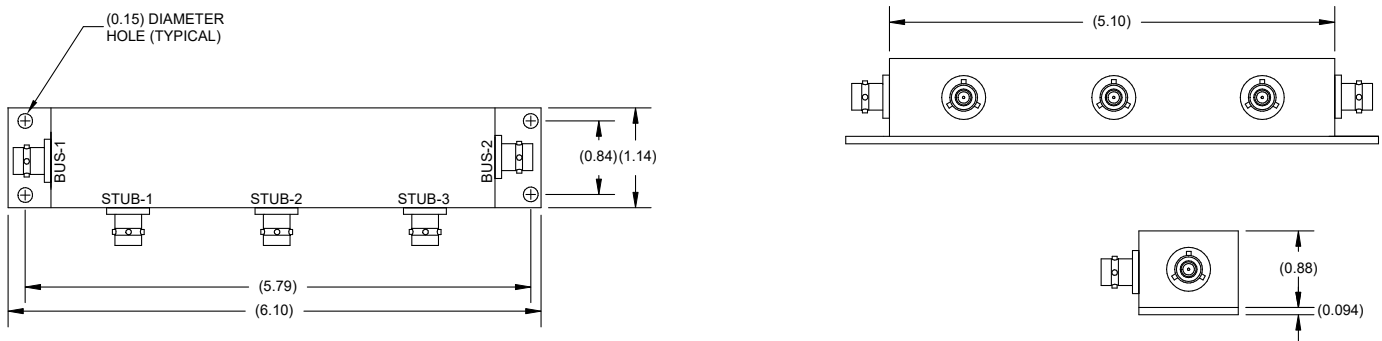

# MIL-STD-1553 Bus Couplers

## TEBC-1004 4 Stub Coupler

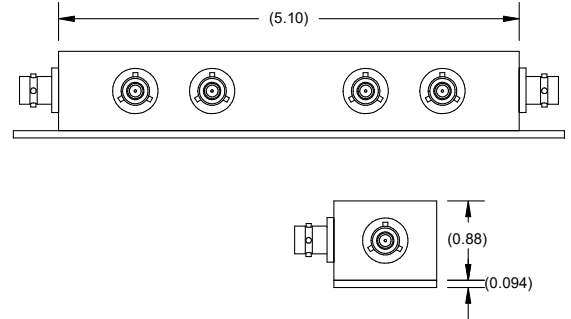
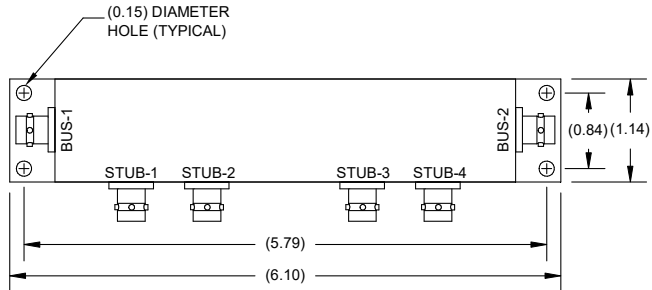

## TEBC-1005 5 Stub Coupler

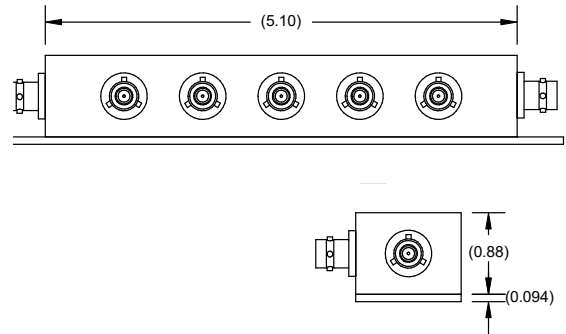
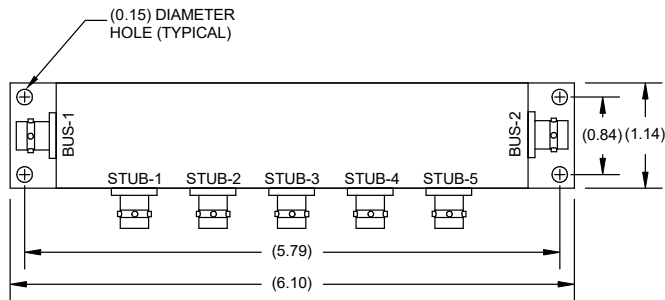

## TEBC-1008 8 Stub Coupler

