

Transfer or duplication of this document as well as the utilisation or communication of its content are not permitted unless express consent is granted. Violations give rise to claims for damages. All rights reserved in case of patent, utility model or design patent registrations.

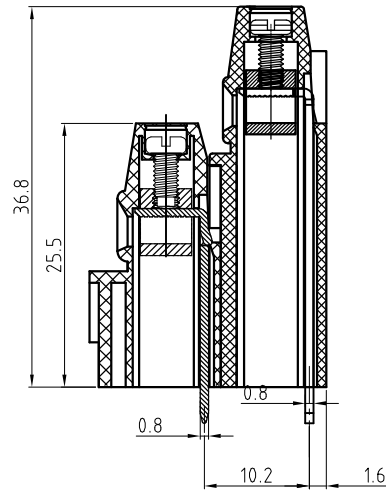
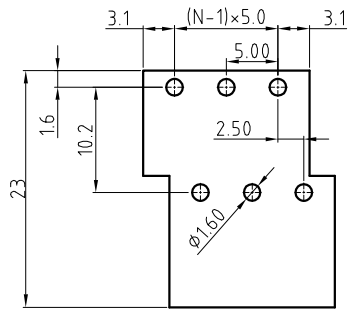
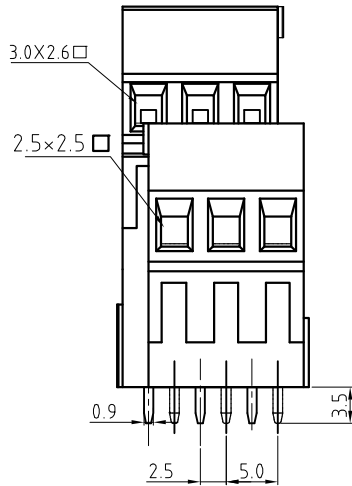
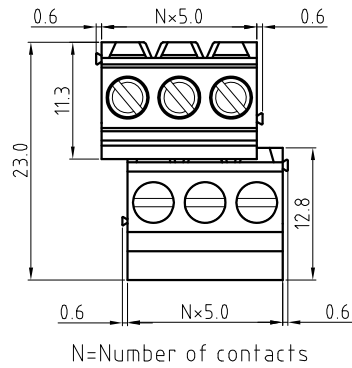

Technical Data:

Electrical

- Pitch: 5.0mm
- Voltage rating: 300V
- Current rating: 16 Amps
- Contact resistance: 20mΩ(max)
- Withstanding Voltage: 2500VAC(1min) Test time=60sec/1pcs
- Wire range: 12-30AWG
- Wire strip length: 6-7mm

Mechanical:

- Torque: 4.5kgf.cm/M2.5
- Operating temperature: -40°C to +105°C
- Soldering temperature: 250°C±10°C / 5 seconds max
- Safety approval (pending):
- RoHS Compliance

Part No.:

OSTYMXX2150

No. of Poles	COLOR
02 2 Poles	0: Black
03 3 Poles	2: Red
... ..	3: Orange
24 24 Poles	4: Yellow
	5: Green (Standard)
	6: Blue
	8: Grey

Nonstandard colors
Mins could apply

5	Screw	Steel / M2.5	Cr3+ plated	2xN
4	Contact	Copper Alloy	Ni plated	2xN
3	Short Terminal	Copper Alloy	Tin plated	1xN
2	Long Terminal	Copper Alloy	Tin plated	1xN
1	Body	PA66 UL94V-0		2
ITEM	NAME OF PART	MATERIAL	NOTES	Q'TY
DWG.	DATE	UNITS: MM	SHEET: 1 OF 1	Tolerance
CHK.	DATE	SCALE: NONE 2:1 (.)	REV.: A	X. ±0.50
APP.	DATE	TITLE: OSTYM SERIES 5.0MM		X.XX ±0.30
		PART NO. OSTYMXX2150		X° ±0.10
		DWG NO. OSTYMXX2150.DWG		X° ±1°

REV	SIGN	DESCRIPTION	CHK.	DATE



ON-SHORE TECHNOLOGY, INC.