

REVISIONS				
P	LTN	DESCRIPTION	DATE	APVD
A	ECO-19-018350		06DEC2019	NN DZ
B	ECR-20-000963		10JAN2020	NN DZ
C	ECO-20-008479		16JUN2020	NN DZ
D	CHANGE MOLEX CONTACT PN AND TIN APPLIED		10APR2021	NN DZ

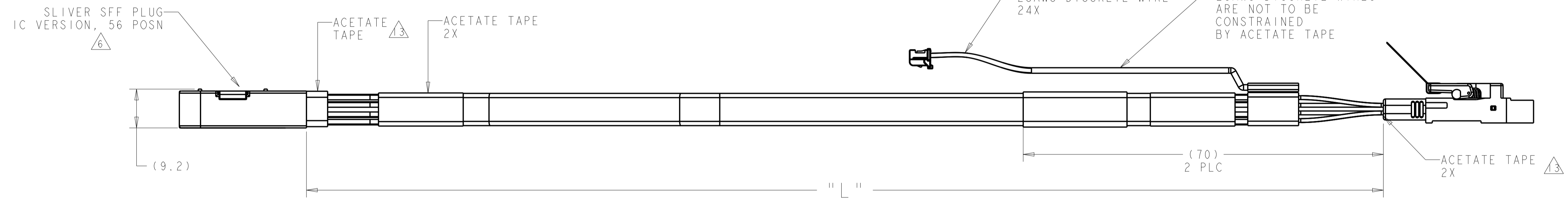
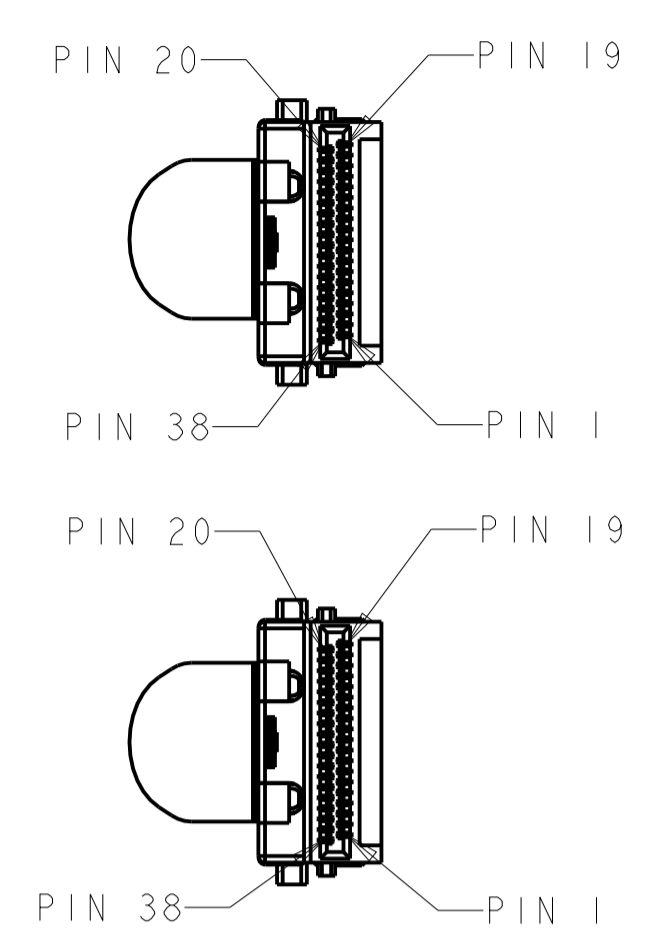
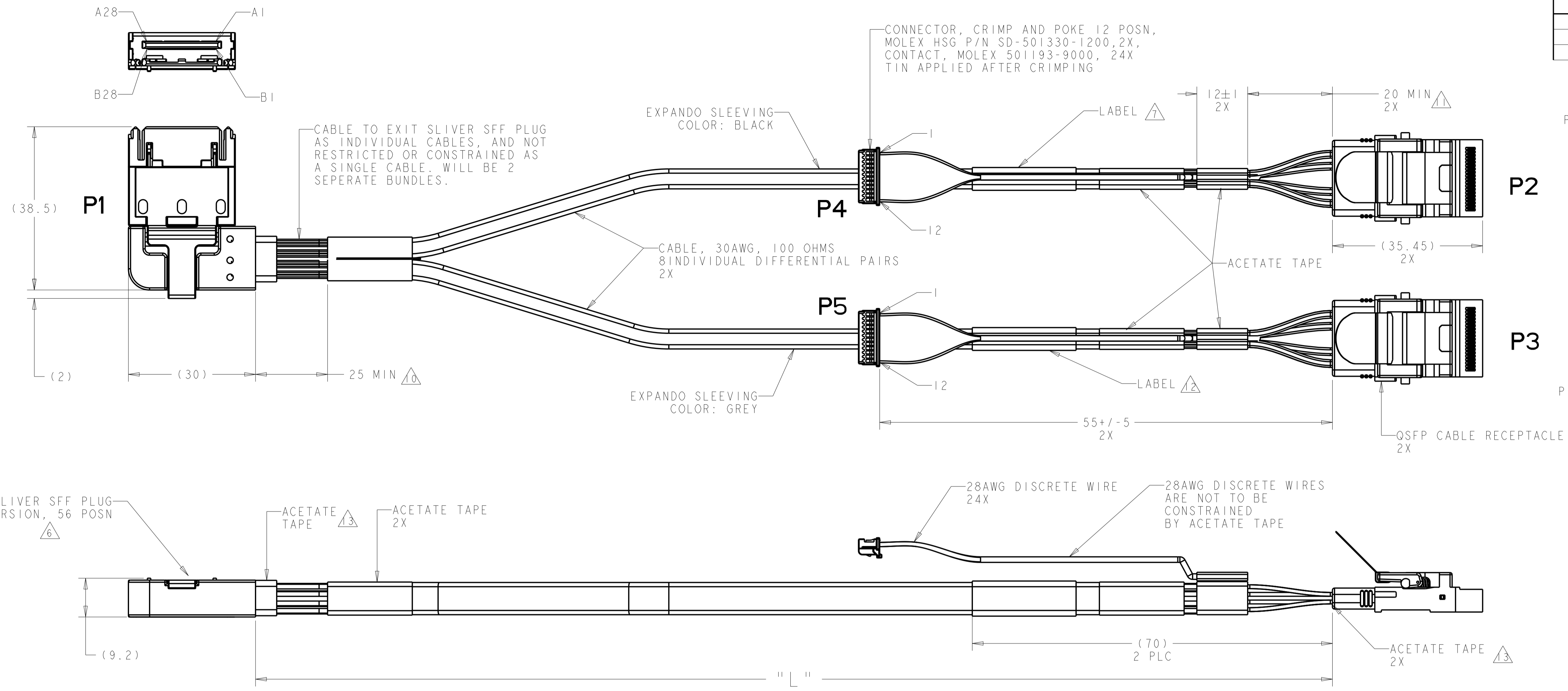

- ALL MATERIALS, COMPONENTS AND PROCESS SHALL COMPLY WITH TEC-138-702. (CONTAINS NO BANNED OR RESTICTED SUBSTANCES).
- NO REACH SVHC SHALL BE CONTAINED ABOVE THE THRESHOLD AS DEFINED IN REACH SVHC COMPLIANCE DEFINITION IN ANNEX A OF TEC-138-702.
- ASSEMBLY TESTED FOR CONTINUITY, OPENS, SHORTS, AND SIGNAL INTEGRITY.
- CABLE BEND RADIUS 10.4MM.
- SEE SHEETS 2 FOR WIRING SCHEMATIC.

△6 CONNECTORS ARE GEN-Z COMPATIBLE.

△7 LABEL INFORMATION SHOWN BELOW:

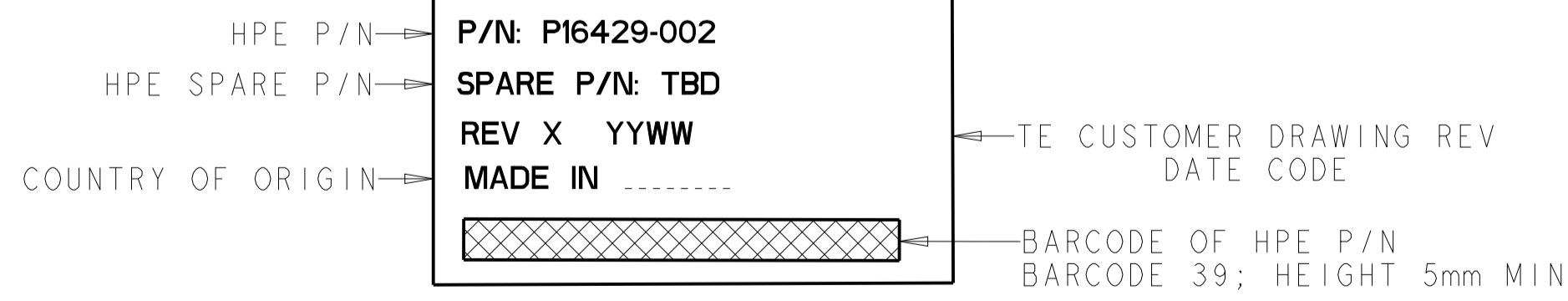

8. SLIVER CABLE CONNECTOR MATES WITH TE SLIVER RECEPTACLE P/N 2332141-X, OR 2332208-X.

△9 PART NUMBERS ARE NOT AVAILABLE AS REPLACEMENT PARTS.

△10 DIMENSION IS TO DEFINE DISTANCE THAT CABLE MUST BE ROUTED AS INDIVIDUAL CABLES BEFORE COVERED WITH TAPE. TAPE BUNDLES ARE SHOWN AS BEING OFFSET FOR CLARITY ONLY, TO DEPICT INDIVIDUAL BUNDLES AFTER THE CABLE IS GROUPED AND BUNDLED.

△11 CABLE EXITING AT OSFP CABLE RECEPTACLE, WILL NOT BE COVERED WITH TAPE, FOR DISTANCE DEFINED BY DIMENSION.

△12 LABEL INFORMATION - I SHOWN BELOW:



△13 ACETATE TAPE TO BE USED DURING OVERMOLDING, TO PREVENT WIRE DAMAGE AT SHUT OFF AREA. TAPE IS NOT TO EXTEND BEYOND OVERMOLD MORE HTAN 5MM MAX.

132 +25/-0	P16429-003	2351524-2
185 +25/-0	P16429-002	2351524-1
"L"	HPE P/N	TE P/N

THIS DRAWING IS A CONTROLLED DOCUMENT. DWN: G. GUITGOLD 25FEB2019

DIMENSIONS:	TOLERANCES UNLESS OTHERWISE SPECIFIED:	APVD	NAME
mm	0 PLC ±	APVD	IC, 56P, SLIVER SFF LATERAL EXIT TO DUAL OSFP, CABLE RECEPT
	1 PLC ±	PRODUCT SPEC	100 OHM, 30AWG
	2 PLC ±	APPLICATION SPEC	SIZE CAGE CODE DRAWING NO
	3 PLC ±	WEIGHT	A100779C=2351524
	4 PLC ±	CUSTOMER DRAWING	RESTRICTED TO
MATERIAL	FINISH	SCALE	1:1
		SHEET	3
		REV	D

REVISIONS				
P.	LTN	DESCRIPTION	DATE	APVD
-	-	SEE SHEET 1	-	-

GROUND POSITIONS ON THE OTB/QSFP CONNECTOR, P2-P3:
 SIDE 1 POSITIONS ARE 1,4,7,13,16,19.
 SIDE 2 POSITIONS ARE 20,23,26,32,35,38.

P1			WIRE TYPE	P2 - P3			
PIN NO.	PAIR NO.	DESIGNATION		DESIGNATION	PAIR NO.	P2 PIN NO.	P3 PIN NO.
A1		GROUND	DRAIN	GROUND			
A2	1	RX1N	30AWG DIFF PAIR	RX1N	1	18	
A3	1	RX1P	30AWG DIFF PAIR	RX1P	1	17	
A4		GROUND	DRAIN	GROUND			
A5	2	RX2P	30AWG DIFF PAIR	RX2P	2	22	
A6	2	RX2N	30AWG DIFF PAIR	RX2N	2	21	
A7		GROUND	DRAIN	GROUND			
A8	3	RX3N	30AWG DIFF PAIR	RX3N	3	15	
A9	3	RX3P	30AWG DIFF PAIR	RX3P	3	14	
A10		GROUND	DRAIN	GROUND			
A11	4	RX4P	30AWG DIFF PAIR	RX4P	4	25	
A12	4	RX4N	30AWG DIFF PAIR	RX4N	4	24	
A13		GROUND	DRAIN	GROUND			
A14		N/C	N/C	N/C			
A15		N/C	N/C	N/C			
A16		GROUND	DRAIN	GROUND			
A17	5	RX1N	30AWG DIFF PAIR	RX1N	5	18	
A18	5	RX1P	30AWG DIFF PAIR	RX1P	5	17	
A19		GROUND	DRAIN	GROUND			
A20	6	RX2P	30AWG DIFF PAIR	RX2P	6	22	
A21	6	RX2N	30AWG DIFF PAIR	RX2N	6	21	
A22		GROUND	DRAIN	GROUND			
A23	7	RX3N	30AWG DIFF PAIR	RX3N	7	15	
A24	7	RX3P	30AWG DIFF PAIR	RX3P	7	14	
A25		GROUND	DRAIN	GROUND			
A26	8	RX4P	30AWG DIFF PAIR	RX4P	8	25	
A27	8	RX4N	30AWG DIFF PAIR	RX4N	8	24	
A28		GROUND	DRAIN	GROUND			

P2		WIRE	P4	
DESIGNATION	DESIGNATION		DESIGNATION	DESIGNATION
8	ModseIL	DISCRETE	ModseIL	7
9	ResetL	DISCRETE	ResetL	8
10	VccRX	DISCRETE	VccRX	9
11	SCL	DISCRETE	SCL	10
12	SDA	DISCRETE	SDA	11
13	GROUND	DISCRETE	GROUND	12
27	ModPrsL	DISCRETE	ModPrsL	6
28	IntL	DISCRETE	IntL	5
29	VccTX	DISCRETE	VccTX	4
30	VccI	DISCRETE	VccI	3
31	LPMoDe	DISCRETE	LPMoDe	2
32	GROUND	DISCRETE	GROUND	1

GROUND POSITIONS ON THE OTB/QSFP CONNECTOR P2-P3:
 SIDE 1 POSITIONS ARE 1,4,7,13,16,19.
 SIDE 2 POSITIONS ARE 20,23,26,32,35,38.

P1			WIRE TYPE	P2 - P3			
PIN NO.	PAIR NO.	DESIGNATION		DESIGNATION	PAIR NO.	P2 PIN NO.	P3 PIN NO.
B1		GROUND	DRAIN	GROUND			
B2	9	TX1P	30AWG DIFF PAIR	TX1P	9	36	
B3	9	TX1N	30AWG DIFF PAIR	TX1N	9	37	
B4		GROUND	DRAIN	GROUND			
B5	10	TX2N	30AWG DIFF PAIR	TX2N	10	2	
B6	10	TX2P	30AWG DIFF PAIR	TX2P	10	3	
B7		GROUND	DRAIN	GROUND			
B8	11	TX3P	30AWG DIFF PAIR	TX3P	11	33	
B9	11	TX3N	30AWG DIFF PAIR	TX3N	11	34	
B10		GROUND	DRAIN	GROUND			
B11	12	TX4N	30AWG DIFF PAIR	TX4N	12	5	
B12	12	TX4P	30AWG DIFF PAIR	TX4P	12	6	
B13		GROUND	DRAIN	GROUND			
B14		N/C	30AWG DIFF PAIR	N/C			
B15		N/C	30AWG DIFF PAIR	N/C			
B16		GROUND	DRAIN	GROUND			
B17	13	TX1P	30AWG DIFF PAIR	TX1P	13	36	
B18	13	TX1N	30AWG DIFF PAIR	TX1N	13	37	
B19		GROUND	DRAIN	GROUND			
B20	14	TX2N	30AWG DIFF PAIR	TX2N	14	2	
B21	14	TX2P	30AWG DIFF PAIR	TX2P	14	3	
B22		GROUND	DRAIN	GROUND			
B23	15	TX3P	30AWG DIFF PAIR	TX3P	15	33	
B24	15	TX3N	30AWG DIFF PAIR	TX3N	15	34	
B25		GROUND	DRAIN	GROUND			
B26	16	TX4N	30AWG DIFF PAIR	TX4N	16	5	
B27	16	TX4P	30AWG DIFF PAIR	TX4P	16	6	
B28		GROUND	DRAIN	GROUND			

P3		WIRE	P5	
DESIGNATION	DESIGNATION		DESIGNATION	DESIGNATION
8	ModseIL	DISCRETE	ModseIL	7
9	ResetL	DISCRETE	ResetL	8
10	VccRX	DISCRETE	VccRX	9
11	SCL	DISCRETE	SCL	10
12	SDA	DISCRETE	SDA	11
13	GROUND	DISCRETE	GROUND	12
27	ModPrsL	DISCRETE	ModPrsL	6
28	IntL	DISCRETE	IntL	5
29	VccTX	DISCRETE	VccTX	4
30	VccI	DISCRETE	VccI	3
31	LPMoDe	DISCRETE	LPMoDe	2
32	GROUND	DISCRETE	GROUND	1

THIS DRAWING IS A CONTROLLED DOCUMENT. DWN G. GUITGOLD 25FEB2019

TE Connectivity

NAME: 1C, 56P, SLIVER SFP LATERAL EXIT TO DUAL QSFP, CABLE RECEPT 100 OHM, 30AWG

SIZE: A1 CAGE CODE: 2351524 DRAWING NO: 100779

SCALE: 1:1 SHEET 2 OF 3 REV D

CUSTOMER DRAWING

REVISIONS				
P.	LTN	DESCRIPTION	DATE	APVD
-	-	SEE SHEET 1	-	-

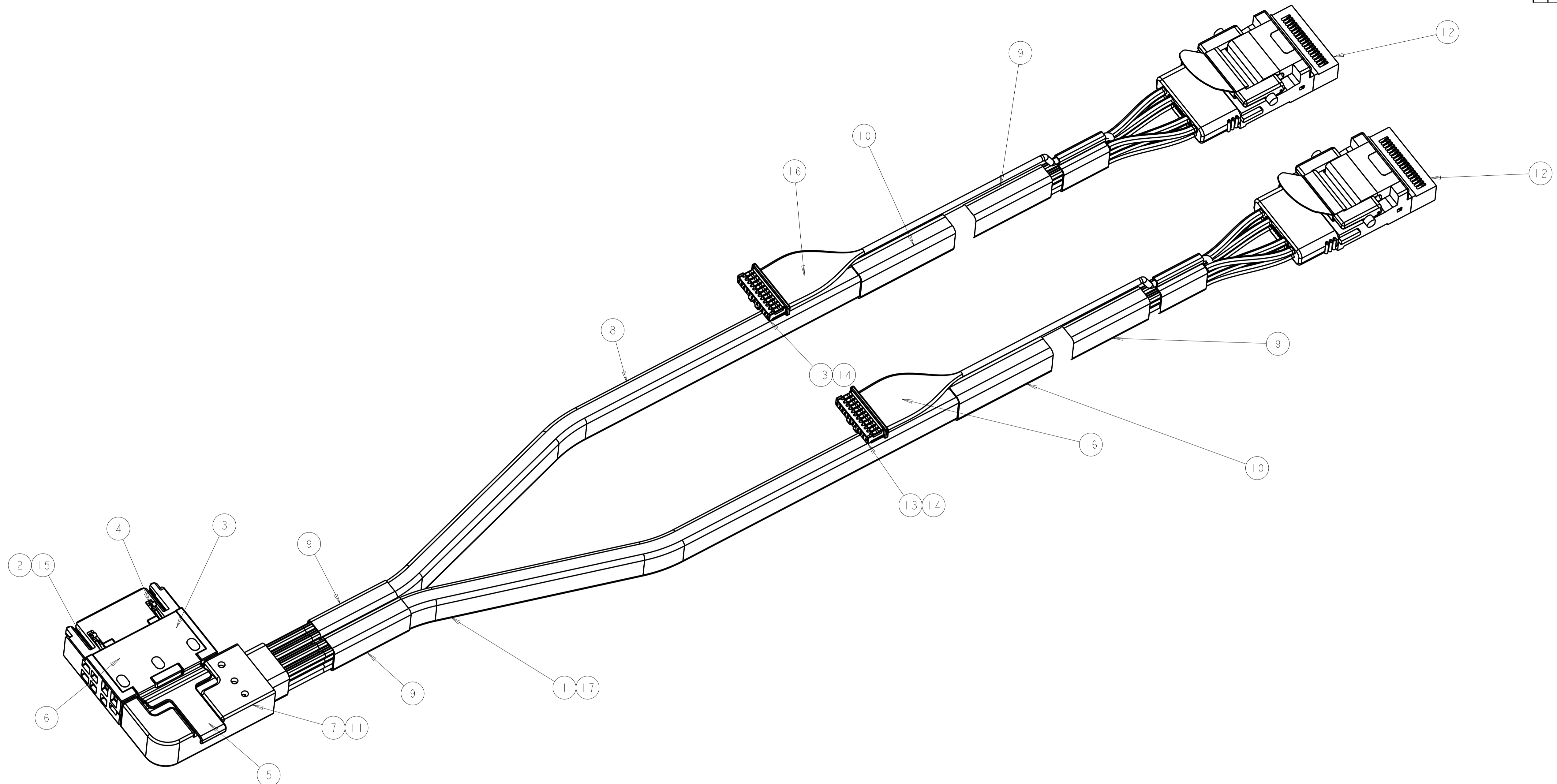

QUANTITY	MATERIAL	PART NUMBER	DESCRIPTION	ITEM
AR	POLYESTER PBT, GREY	2355487-2	SLEEVING, EXPANDO	17
AR	COMPLEX ARTICLE	2355478	WIRE, 28AWG, SOLID CONDUCTOR, SLIVER PLATED	16
2	BRASS, Ni, Sn	2821908	GROUND RAKE, 30AWG, 8 DIFF PAIRS	15
2	NYLON	2354116-1	HOUSING, 12 POSN, MOLEX SD-501330-1200	14
24	PHOS BRNZ Ni, Sn, Au PLATING	3311207-5	CONTACT, 28-32AWG, MOLEX 501193-9000	13
2	COMPLEX ARTICLE	2352298	RECEPTACLE ASSY, QSFP OTB	12
AR	POLYPROPYLENE, 30% GLASS	2136840	MOLDING COMPOUND, PP	11
2	POLYESTER	1537068	LABEL	10
AR	ACETATE TAPE	1876042	TAPE, 0.75 WIDE	9
AR	POLYESTER PBT, BLACK	2355487-1	SLEEVING, EXPANDO	8
AR	MACROMELT OM 638	2127074	MOLD COMPOUND	7
AR	LOW HAL POLYCARBONATE	2351566	COVER	6
AR	LOW HAL NYLON	2351567	PULL TAB	5
2	SS	2351795	LATCH	4
AR	LOW HAL POLYCARBONATE	2351240	HOUSING	3
1	EMC EM-888 OR TUC TU-863	2350663	PCB, 30AWG, 100 OHM, WITH 0 OHM RESISTORS	2
AR	COMPLEX ARTICLE	2337564	CABLE, 30AWG, 100 OHM, SINGLE DIFF PAIR	1

THIS DRAWING IS A CONTROLLED DOCUMENT. DWN LG_GUITGOLD 25FEB2019

TE Connectivity

NAME: 1C, 56P, SLIVER SFP LATERAL EXIT TO DUAL QSFP, CABLE RECEPT
100 OHM, 30AWG

SIZE: A1 CAGE CODE: 100779 DRAWING NO: 2351524

SCALE: 1:1 SHEET 3 OF 3 REV D