

OA172SAP-XC Series

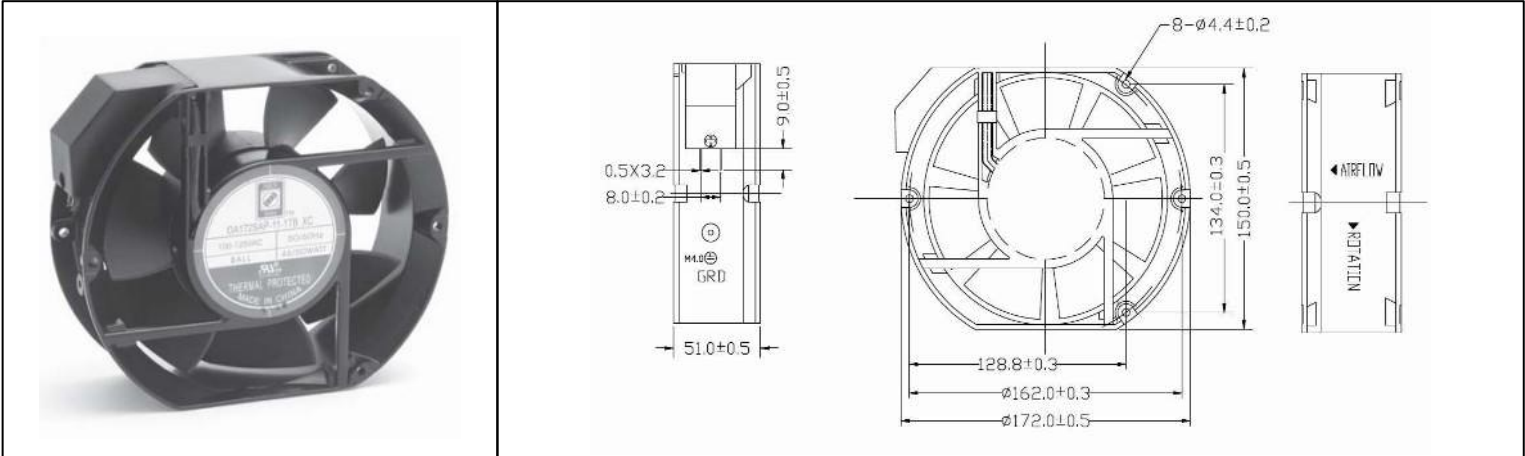

AC Fan - 115V, 230V
172x150x51mm (6.7"x5.9"x2.0")



Frame	Diecast Aluminum, Black Finish	Operating Temperature -10°C ~ +65°C Storage Temperature -40°C ~ +75°C Life Expectancy 50,000 hours (L10 at 25°C) Weight: 2.14 lbs m4	
Impeller	PBT, UL94 V-0 plastic		
Connection	2x Lead wires 24 AWG		
Motor	Capacitor Drive, Thermally Protected		
Bearing System	Dual Ball Bearings		
Dielectric Strength	1500VAC/min, 50/60Hz		
Insulation Resistance	10M ohm between leadwires and frame (500 VDC)		

Part Number	Rated Voltage	Input Power	Rated Current	Rated Speed (RPM)	Airflow (CFM)	Noise Level (dB)	Max. Static Pressure
OA172SAP-11-1*B XC	115 VAC	50 W (60Hz)	0.40 A	3300	293	61	0.78" H ₂ O
OA172SAP-22-1*B XC	230 VAC	50 W (60Hz)	0.22 A	3300	293	61	0.78" H ₂ O

* Indicates "T" for terminal or "W" for wire leads