

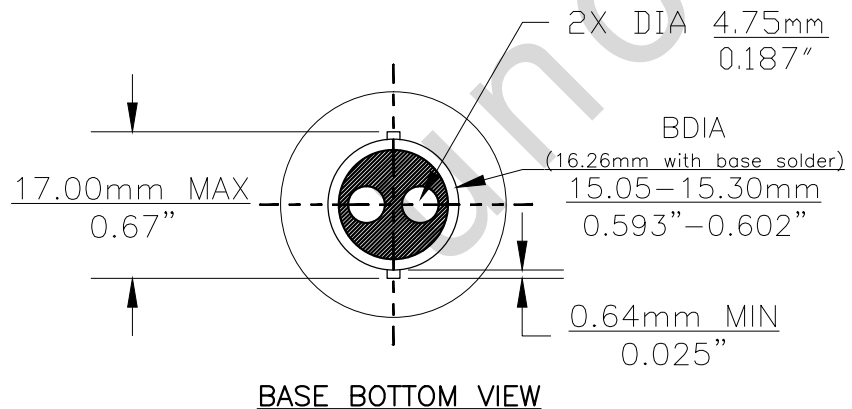

PART NO.	BASE TYPE	DESIGN VOLTS	DESIGN AMPS	MSCD	FILAMENT TYPE	AVERAGE LIFE HOURS
1157NA	D.C. INDEX BAY15d	12.8V 14.0V	2.1 ±5% 0.59 ±8%	24±30% 2.2±30%	C-6 C-6	1200 5000

REVISIONS			
REV #	DESCRIPTION	DATE	APPROVED
1	ISSUED	02/01/2001	E.S.
2	REDREW, ADDITIONAL VIEWS	02/15/2005	D.C.
3	REVISED LIFE HOURS	06/28/2013	D.C.
4	REVISED BASE DIMENSIONS	03/04/2019	R.M.

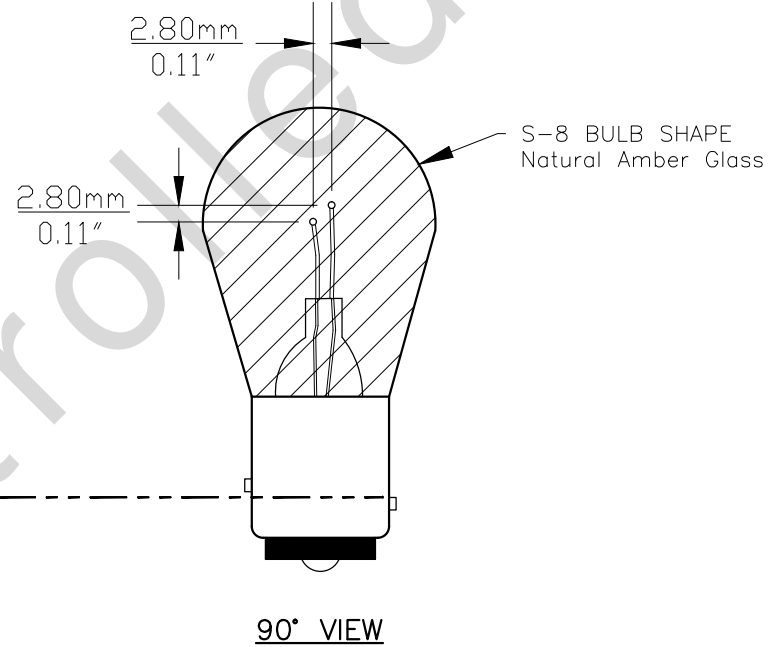
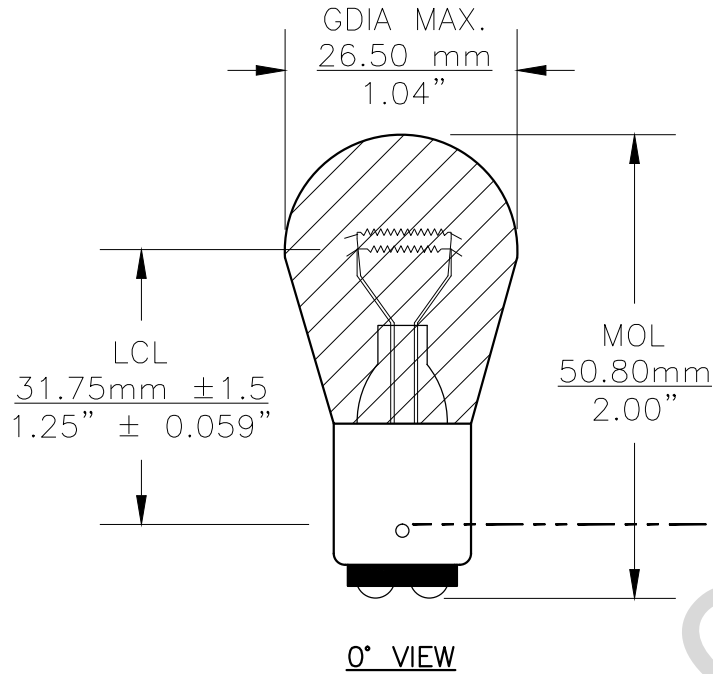

Note: Made according to SAE specifications

UNLESS OTHERWISE SPECIFIED: DIMENSIONS ARE IN INCHES TOLERANCES		CEC INDUSTRIES LTD	
DECIMALS .XX ± .05	ANGULAR ± 0.5°	99 BOND STREET	LINCOLNSHIRE, IL 60069
.XXX ± .010	FRACTIONAL ± 1/64	TITLE LIGHT BULB NO. 1157NA	
DRAWN ELIZABETH SONANES	DATE 02/01/2001	SIZE A	FSCM NO. DWG NO. 1157NA REV 4
CHECKED	DESIGN	SCALE	PLOT SCALE SHEET 1 OF 1
MATERIAL	FILE 1157NA.pdf	DRAWING NOT TO SCALE	