

PART NUMBER	REV	FIRST USED	SUPSD BY
466299-1	G	854400-1	SUPSD BY -3
466299-2	G	565435-5	SUPSD BY -4
466299-3	R	854400-1	
466299-4	R	565435-5	
466299-5	R	354500-1	

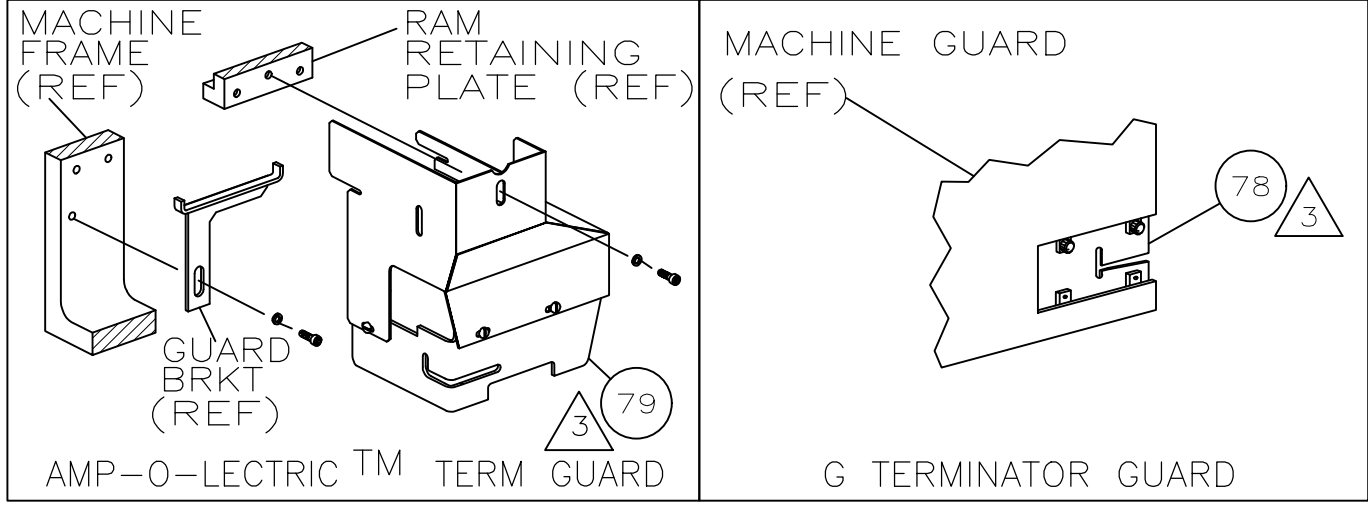

TERMINAL NAME: .110 FLAG FASTON RECPT		CRIMPING DATA			
GROUP I	GROUP II	PAD LTR	CRIMP HEIGHT	WIRE SIZE	CRIMP HEIGHT
0126 STK	0098 STK	A	.051 ±.002	18	NOT USED
60605	61372	B	.045 ±.002	20	.045 ±.002
61001	61459	C	.040 ±.002	22	.040 ±.002
63592-1	61530	D	NOT USED		.036 ±.002
1217878	61971				
	62784				
	141352-2				
		CRIMP	SIZE	TYPE	RANGE
		WIRE	.070		
		INSUL	.110	0	
		FEED	APPL INST 408-8039	SET UP GAGE 458638-1	LAYOUT 186
		WIRE STRIP LENGTH -			

REVISIONS					
P	LTR	DESCRIPTION	DATE	DWN	APVD
R		ECR-19-007885	17MAY2019	GK	GB

-3	LEADMAKER	AIRFEED
-4	BENCH MODEL K	AIRFEED
-5	BENCH MODEL G	AIRFEED

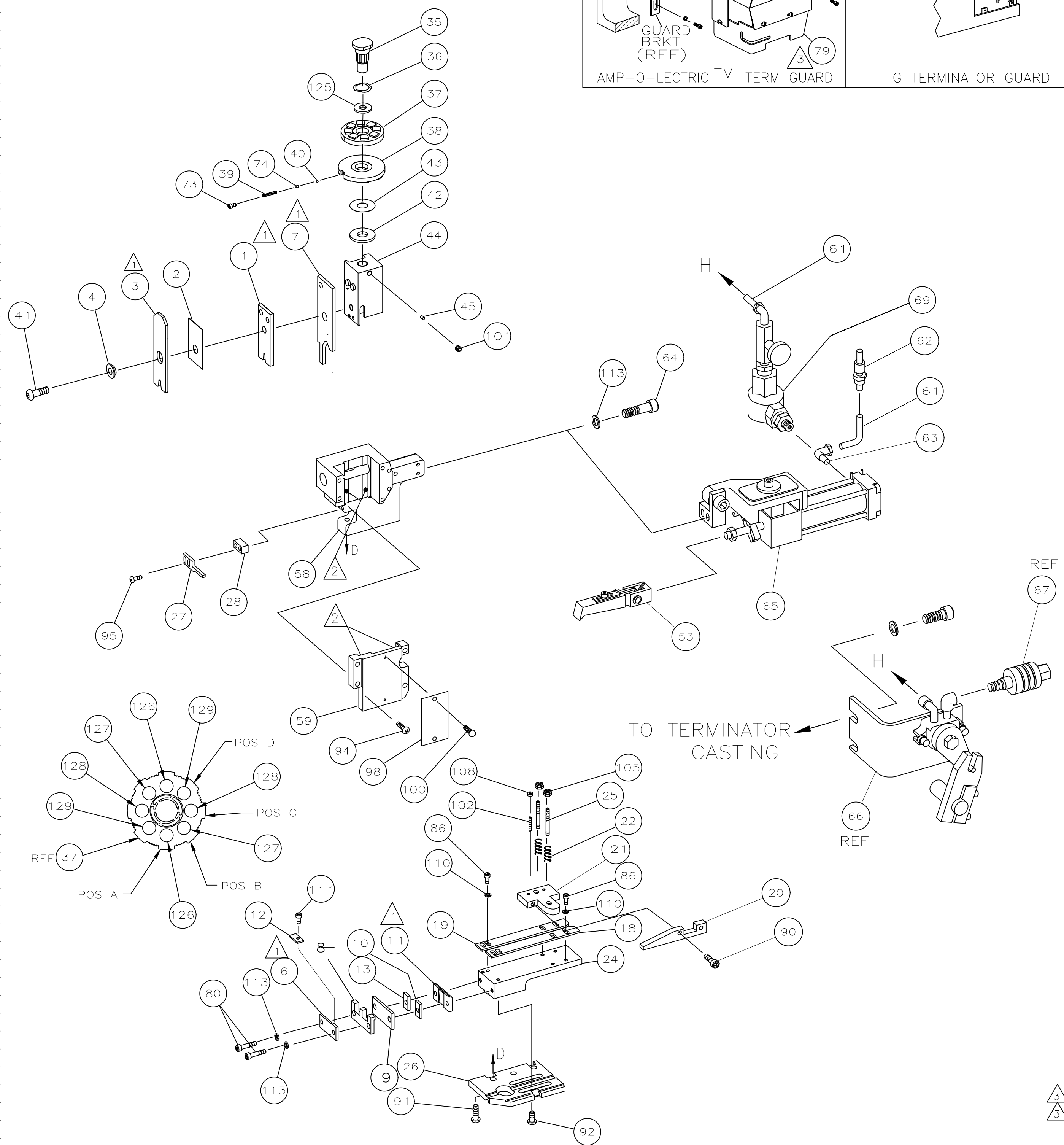

2	2	2	-	C	4-354779-4	PIN, WIRE DISC (.3210)D	129
2	2	2	-	C	3-354779-6	PIN, WIRE DISC (.3170)C	128
2	2	2	-	C	2-354779-6	PIN, WIRE DISC (.3120)B	127
2	2	2	-	C	1-354779-4	PIN, WIRE DISC (.3060)A	126
1	1	1	-	A	986950-1	WASHER, FLAT PRECISION	125
							124
							123
							122
							121
							120
							119
							118
							117
							116
							115
							114
4	4	4	-	A	21024-5	WASHER, LOCK(NO.10)SHEAR PL	113
							112
1	1	1	-	A	6-21000-2	SCR,SHC(5-40X.25)STOP,TERM	111
4	4	4	-	A	21024-4	WASHER, LOCK(#8)SHEAR BL	110
							109
2	2	2	-	A	21018-4	NUT, HEX(4-40)DRAG	108
							107
							106
2	2	2	-	A	21022-2	NUT, HEX SL(8-32)DRAG STUD	105
							104
							103
2	2	2	-	A	4-21078-8	SKT SKT SET (4-40X.75)DRAG	102
1	1	1	-	A	21009-2	SCR,SKT SET(1/4-20X.25 )RAM	101
2	2	2	-	A	21017-2	SCR,DRIVE(#2X.19)ID PLATE	100
							99
1	1	1	-	B	461264-1	PLATE, IDENTIFICATION	98
							97
							96
2	2	2	-	A	2-21002-4	SCR,BHC(8-32X.75)STRIPPER	95
4	4	4	-	A	2-21002-9	SCR,BHC(10-32X.75)CAP	94
							93
4	4	4	-	A	3-21002-3	SCR,BHC(1/4-20X.50)ST GD PL	92
3	3	3	-	A	2-22733-8	SCR,BHC(1/4-20X.62)HSG	91
2	2	2	-	A	1-21000-3	SCR,SHC(4-40X.25)DRAG	90
							89
							88
							87
							86
4	4	4	-	A	2-21000-6	SCR,SHC(8-32X.38)STRIP GUIDE	85
							84
							83
							82
							81
2	2	2	-	A	3-21000-9	SCR,SKT CAP(10-32X.1.00)SH PL	80
-	1	-	-	A	455750-8	GUARD ASSY	79
REF	-	-	-	A	679532-1	INSERT, GUARD	78
							77
							76
							75
1	1	1	-	A	690603-1	SPRING, ASSIST	74
1	1	1	-	A	23030-1	SCR,SKT CAP(6-32X.25)CP DSC	73
							72
							71
							70

1	1	1	-	C	692655-5	AIR FEED VALVE ASSY	70
							69
							68
-	REF	-	-	A	24042-2	VALVE, SHUT OFF	67
-	REF	-	-	C	692655-6	AIR FEED VALVE ASSY	66
1	1	1	-	B	460277-1	AIR FEED ASSY	65
2	2	2	-	A	3-21000-9	SCR,SHC 10-32X1.00 AIR ASSY	64
1	-	1	-	A	980285-2	ELBOW, TUBING 1/8NPT - 1/4 T	63
1	-	1	-	A	23238-1	QUICK DISCONNECT	62
12.00	12.00	12.00	IN	A	27319-4	TUBING, POLY-FLO Ø.25	61
							60
1	1	1	-	C	454220-1	CAP, RAM	59
1	1	1	-	D	453736-2	HOUSING	58
							57
							56
							55
							54
1	1	1	-	B	1-460680-8	FEED FINGER ASSY	53
							52
							51
							50
							49
							48
							47
							46
1	1	1	-	A	690191-1	PLUG, NYLON	45
1	1	1	-	C	455674-5	RAM	44
1	1	1	-	A	690125-1	WASHER, LAMINATED	43
1	1	1	-	A	690124-4	WASHER, RAM	42
1	1	1	-	A	690686-2	BOLT, CRIMPER(5/16-24X1.00)	41
1	1	1	-	A	23241-6	BALL, STEEL	40
1	1	1	-	A	690170-1	SPRING, COMPRESSION	39
1	1	1	-	C	690142-1	DISC, INSULATION	38
1	1	1	-	D	354777-1	WIRE DISC, PLASTIC	37
1	1	1	-	A	22480-5	WASHER, SPRING	36
1	1	1	-	B	690212-1	POST, RAM	35
							34
							33
							32
							31
							30
							29
1	1	1	-	B	690451-8	SPACER, STRIPPER	28
1	1	1	-	A	240639-2	STRIPPER	27
1	1	1	-	D	459717-1	PLATE, BASE	26
2	2	2	-	A	22354-8	DRAG, STUD	25
1	1	1	-	B	455678-1	PLATE, STRIP GUIDE	24
							23
							22
2	2	2	-	A	22281-9	SPRING, DRAG	21
1	1	1	-	A	464451-1	ARM, STOCK DRAG	20
1	1	1	-	A	464452-5	DRAG, STOCK	19
1	1	1	-	B	454204-5	GUIDE, STRIP (REAR)	18
1	1	1	-	C	690871-1	GUIDE, STRIP (FRONT)	17
							16
							15
							14
1	1	1	-	C	1-240645-4	SPACER, SHEAR PLATE(REAR)	13
1	1	1	-	B	690815-1	STOP, TERMINAL	12
1	1	1	-	B	690814-1	PLATE, REAR SHEAR	11
1	1	1	-	C	1-240645-6	SPACER, SHEAR PLATE(FRONT)	10
1	1	1	-	B	690619-6	PLATE, RETAINING	9
1	1	1	-	D	3-690618-3	ANVIL, WIRE	8
1	1	1	-	B	461297-1	BLADE, SLUG	7
1	1	1	-	D	690816-1	ANVIL, INSULATION	6
							5
1	1	1	-	B	238009-1	SPACER, BLOCK CRIMPER	4
1	1	1	-	C	461296-1	CRIMPER, INSULATION	3
1	1	1	-	B	1-455888-3	SPACER, CRIMPER	2
1	1	1	-	C	2-459736-4	CRIMPER, WIRE	1

- 1 RECOMMENDED SPARE PARTS.
- 2 GREASE LIGHTLY.
- 3 GUARD MUST BE IN PLACE WHEN OPERATING APPLICATOR IN A BENCH MACHINE.
- 4 SEE DRAWING FOR COMPONENTS

QTY REQD PER ASSY	U/M	DWG SIZE	PART NO	DESCRIPTION	ITEM NO
REVISION OF EACH ASSY NO (WHEN BLANK, USE DWG REVISION)					
PARTS LIST					

QTY REQD PER ASSY	U/M	DWG SIZE	PART NO	DESCRIPTION	ITEM NO
REVISION OF EACH ASSY NO (WHEN BLANK, USE DWG REVISION)					
PARTS LIST					

THIS DRAWING IS A CONTROLLED DOCUMENT.

DIMENSIONS: INCHES	TOLERANCES UNLESS OTHERWISE SPECIFIED:	DWG: P. MATHIAS 9/13/94	APVD: A. REDDICK 9-15-94
0 PLC ± .01	1 PLC ± .02	NAME: C. ERISMAN	NAME: A. REDDICK
2 PLC ± .025	3 PLC ± .03	PRODUCT SPEC: END FEED HDM APPLICATOR	APPLICATION SPEC: -
4 PLC ± .04	ANGLES ± .5	SIZE: A1	CAGE CODE: 00779
MATERIAL: -	FINISH: -	WEIGHT: 0.000000	DRAWING NO: C-466299
MACHINE REF: MINI APPL		CUSTOMER DRAWING	SCALE: - SHEET 1 OF 1 REV R