

## CDBMTS120-HF Thru. CDBMTS1200-HF

Reverse Voltage: 20 to 200 Volts

Forward Current: 1.0 Amp

RoHS Device

Halogen Free

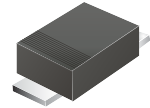

### Features

- Excellent power dissipation offers better reverse leakage current and thermal resistance.
- Low profile package is 40% thinner than standards SOD-123.
- Low power loss,high efficiency.
- High current capability,low forward voltage drop.
- High surge capability.
- Guarding for overvoltage protection.
- Ultra high-speed switching.
- Silicon epitaxial planar chip,metal silicon junction.
- Lead-free part meets environmental standards of MIL-STD-19500/228

### Mechanical data

- Epoxy: UL94-V0 rated flame retardant.
- Case: Molded plastic, SOD-123S/MINI SMA
- Terminals: Solderable per MIL-STD-750, Method 2026.
- Polarity: Indicated by cathode band.
- Mounting Position: any
- Weight: 0.0155 grams approx.

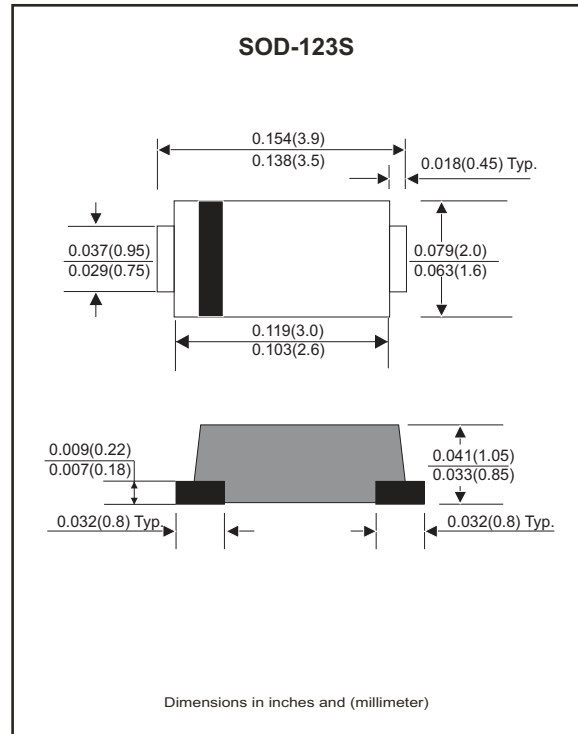

### Electrical Characteristics (at T<sub>A</sub>=25°C unless otherwise noted)

Parameter	Symbol	CDBMTS 120-HF	CDBMTS 130-HF	CDBMTS 140-HF	CDBMTS 150-HF	CDBMTS 160-HF	CDBMTS 180-HF	CDBMTS 1100-HF	CDBMTS 1150-HF	CDBMTS 1200-HF	Unit	
Repetitive peak reverse voltage	V <sub>RRM</sub>	20	30	40	50	60	80	100	150	200	V	
Continuous reverse voltage	V <sub>R</sub>	20	30	40	50	60	80	100	105	140	V	
RMS voltage	V <sub>RMS</sub>	14	21	28	35	42	56	70	150	200	V	
Maximum Forward rectified current	I <sub>O</sub>	1.0									A	
Maximum forward voltage @ I <sub>F</sub> =1.0A	V <sub>F</sub>	0.50			0.70		0.85		0.92		V	
Maximum forward surge current 8.3ms single half sine-wave superimposed on rated load (JEDEC methode)	I <sub>FSM</sub>	30									A	
Maximum reverse Current (V <sub>R</sub> =V <sub>RRM</sub> )	T <sub>J</sub> =25°C	0.5									mA	
	T <sub>J</sub> =100°C	10										
Typical diode Junction capacitance (F=1MHz and applied 4V DC reverse voltage)	C <sub>J</sub>	120									pF	
Operating temperature	T <sub>J</sub>	-55 to +125				-55 to +150						°C
Storage temperature range	T <sub>STG</sub>	-65 to +175									°C	

## Rating and Characteristic Curves (CDBMTS120-HF Thru. CDBMTS1200-HF)

Fig.1- Typical Forward Current Derating Curve

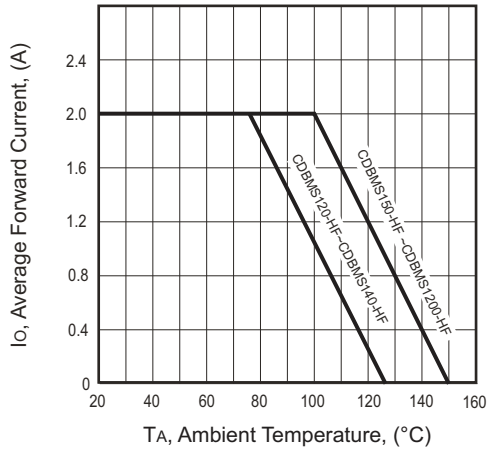

Fig.2 - Typical Forward Characteristics

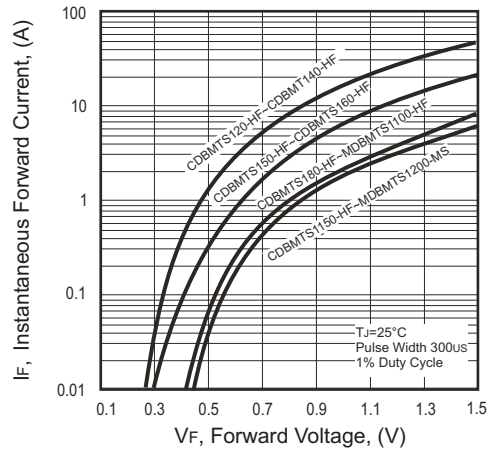

Fig.3 - Maximum Non-repetitive Forward Surge Current

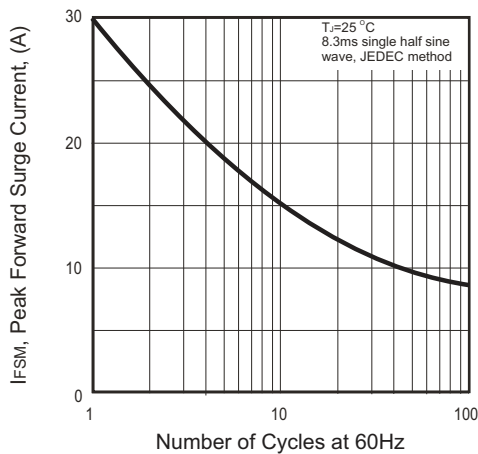

Fig.4 - Typical Junction Capacitance

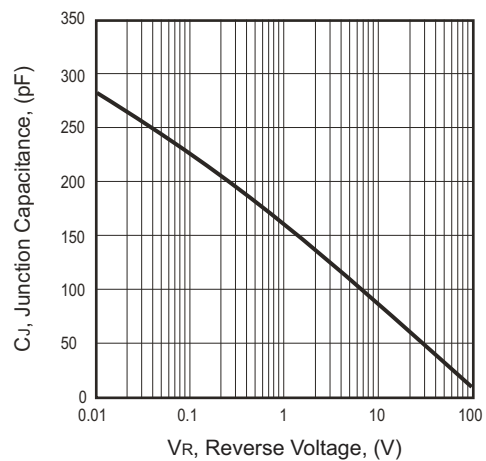
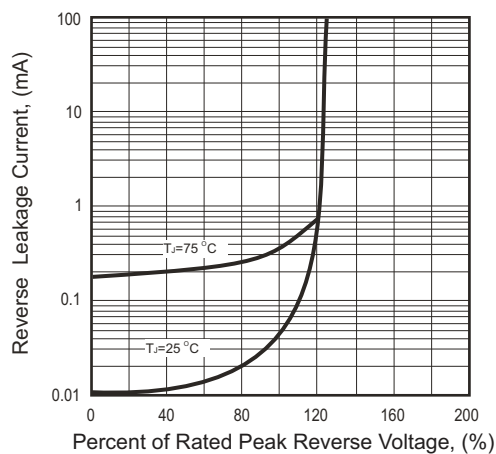
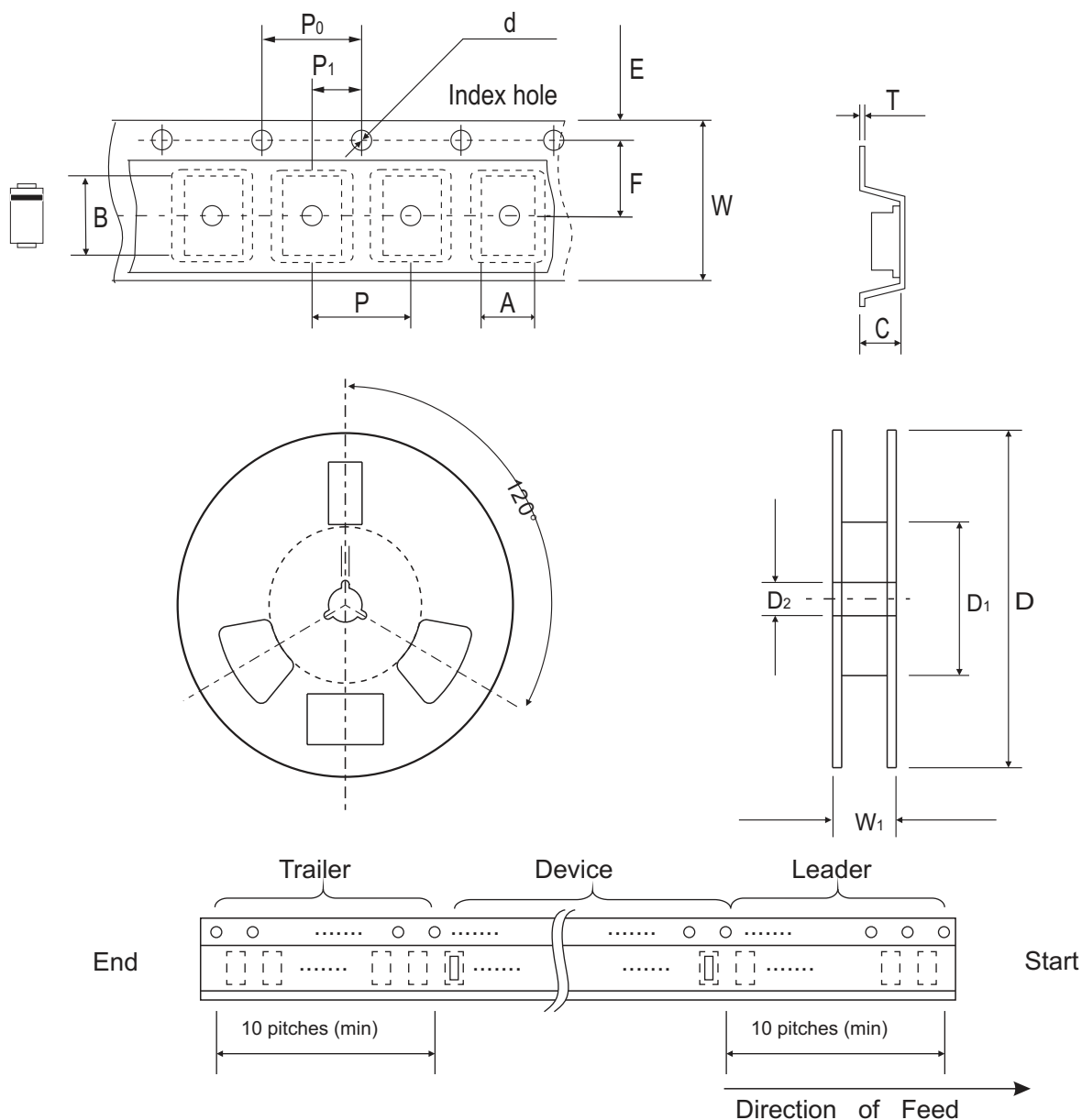

Fig.5 - Typical Reverse Characteristics





## Reel Taping Specification



SOD-123S	SYMBOL	A	B	C	d	D	D1	D2
	(mm)	$2.00 \pm 0.10$	$3.85 \pm 0.10$	$1.10 \pm 0.10$	$1.50 \pm 0.10$	$178 \pm 2.00$	62.0 MIN.	$13.0 \pm 0.50$
	(inch)	$0.079 \pm 0.004$	$0.152 \pm 0.004$	$0.043 \pm 0.004$	$0.059 \pm 0.004$	$7.00 \pm 0.079$	2.440 MIN.	$0.512 \pm 0.020$

SOD-123S	SYMBOL	E	F	P	P0	P1	T	W	W1
	(mm)	$1.75 \pm 0.10$	$3.50 \pm 0.10$	$4.00 \pm 0.10$	$4.00 \pm 0.10$	$2.00 \pm 0.10$	$0.23 \pm 0.10$	$8.00 \pm 0.30$	$11.40 \pm 1.0$
	(inch)	$0.069 \pm 0.004$	$0.138 \pm 0.004$	$0.157 \pm 0.004$	$0.157 \pm 0.004$	$0.079 \pm 0.004$	$0.009 \pm 0.004$	$0.315 \pm 0.012$	$0.449 \pm 0.039$

## Pinning information

Pin	Simplified outline	Symbol
PIN 1 Cathode PIN 2 Anode		

## Marking Code

Part Number	Marking Code
CDBMTS120-HF	12
CDBMTS130-HF	13
CDBMTS140-HF	14
CDBMTS150-HF	15
CDBMTS160-HF	16
CDBMTS180-HF	18
CDBMTS1100-HF	10
CDBMTS1150-HF	115
CDBMTS1200-HF	120



xx / xxx = Product type marking code

## Suggested PAD Layout

SIZE	SOD-123S	
	(mm)	(inch)
A	3.00	0.118
B	1.00	0.039
C	0.90	0.036
D	4.00	0.157
E	2.00	0.079

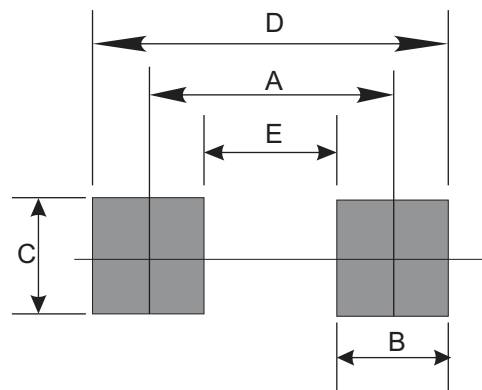

## Standard Packaging

Case Type	REEL PACK	
	REEL ( pcs )	Reel Size (inch)
SOD-123S	2,500	7