

LOC		DIST		REVISIONS			
P	LTR	DESCRIPTION	DATE	DMN	APVD		
C		REVISED PER ECO-08-017244	14JUL08	HMR	DB		
D		ECR-13-014450	12OCT13	MT	DZ		

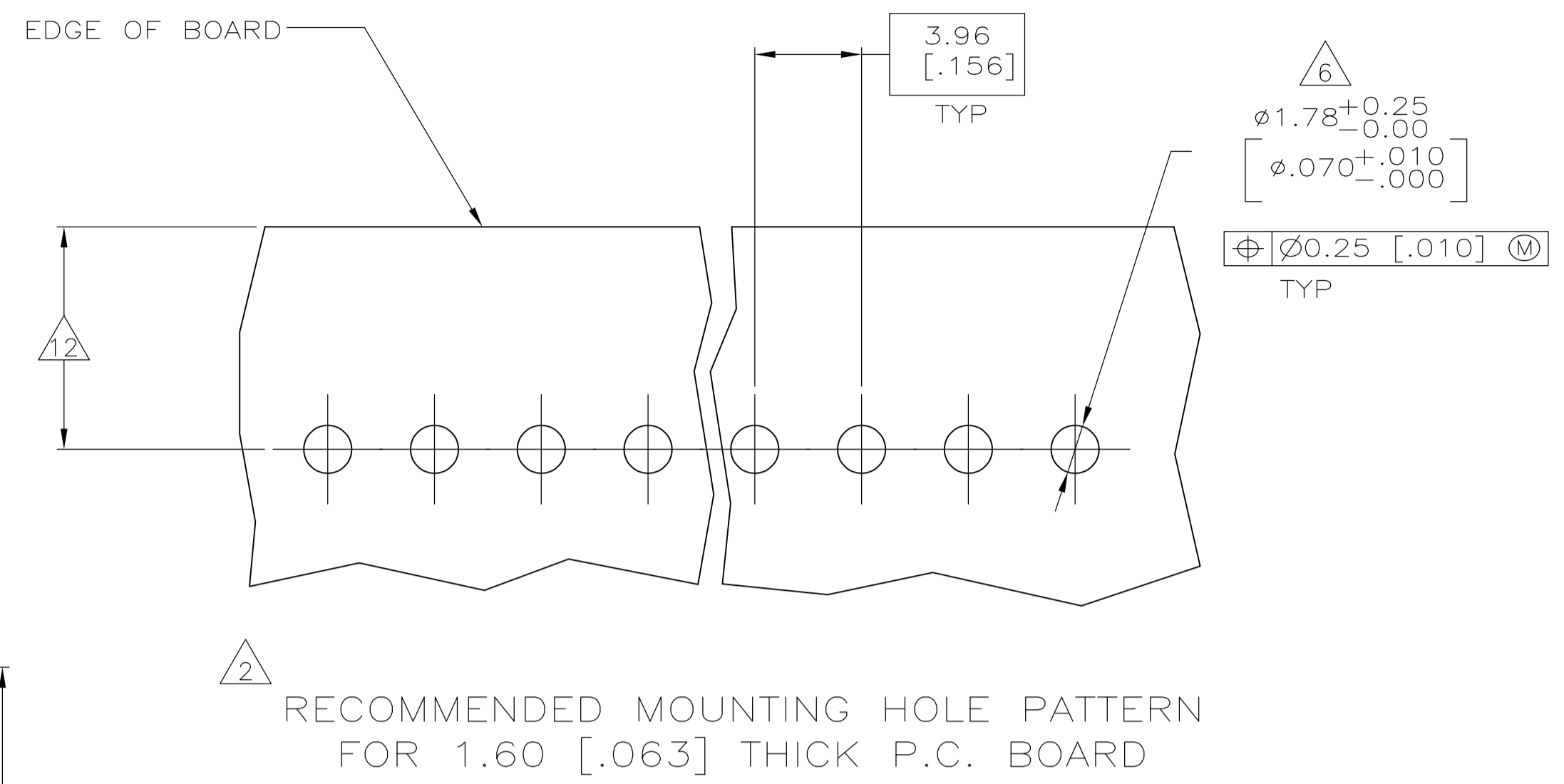

- 1 POST TO WITHSTAND 13 NEWTONS (3 LBS) MINIMUM AXIAL FORCE IN BOTH DIRECTIONS SHOWN WITHOUT DISLODGING.
- 2 TOLERANCES APPLY TO SOLDER SIDE OF BOARD.
- 3 MEASURED AT SURFACE  $\overline{-A-}$
- 4 PLASTIC FLASH PERMITTED IN THIS AREA.
- 5 PARTS COMPLY WITH AMP SOLDERABILITY SPEC. NO. 109-11-2.
- 6 ONE HOLE MAY BE UNDERSIZED 1.65-1.52 [.065-.060] DIA. FOR ASSEMBLY RETENTION DURING WAVE SOLDERING.
- 7 MATERIAL: HEADER-THERMOPLASTIC POLYESTER  
GLASS-FILLED 94V-0 (NATURAL)  
POST-COPPER ALLOY (TIN PLATED)  
PLATING-ITEMS MARKED CONTAINS MATTIE TIN  
ITEMS MARKED LEAD FREE-MATTE TIN
- 8 COORDINATE DIMENSION APPLIES FROM CENTER OF ACTUAL FEATURE.
- 9 PLASTIC BURRS CAUSED BY CUT-OFF TOOLING ARE PERMITTED WITHIN THE MAXIMUM TOLERANCE ENVELOPE.
- 10 POST TO BE MEASURED WHEN STRIP IS HELD FLAT.
- 11 POST MUST WITHSTAND TWO 90° BENDS AGAINST EXTRUSION WITHOUT BREAKING.
- 12 DIMENSION SHOULD BE 4.45 [.175] MIN WHEN MATING WITH A MTA-156 CONNECTOR ASSEMBLY OR A SL-156 CONNECTOR ASSEMBLY.
- 13 PIN BURR OF 0.13 [.005] MAXIMUM VERTICAL AND 0.08 [.003] MAXIMUM HORIZONTAL PERMITTED AT POST TIPS ON BOTH ENDS.

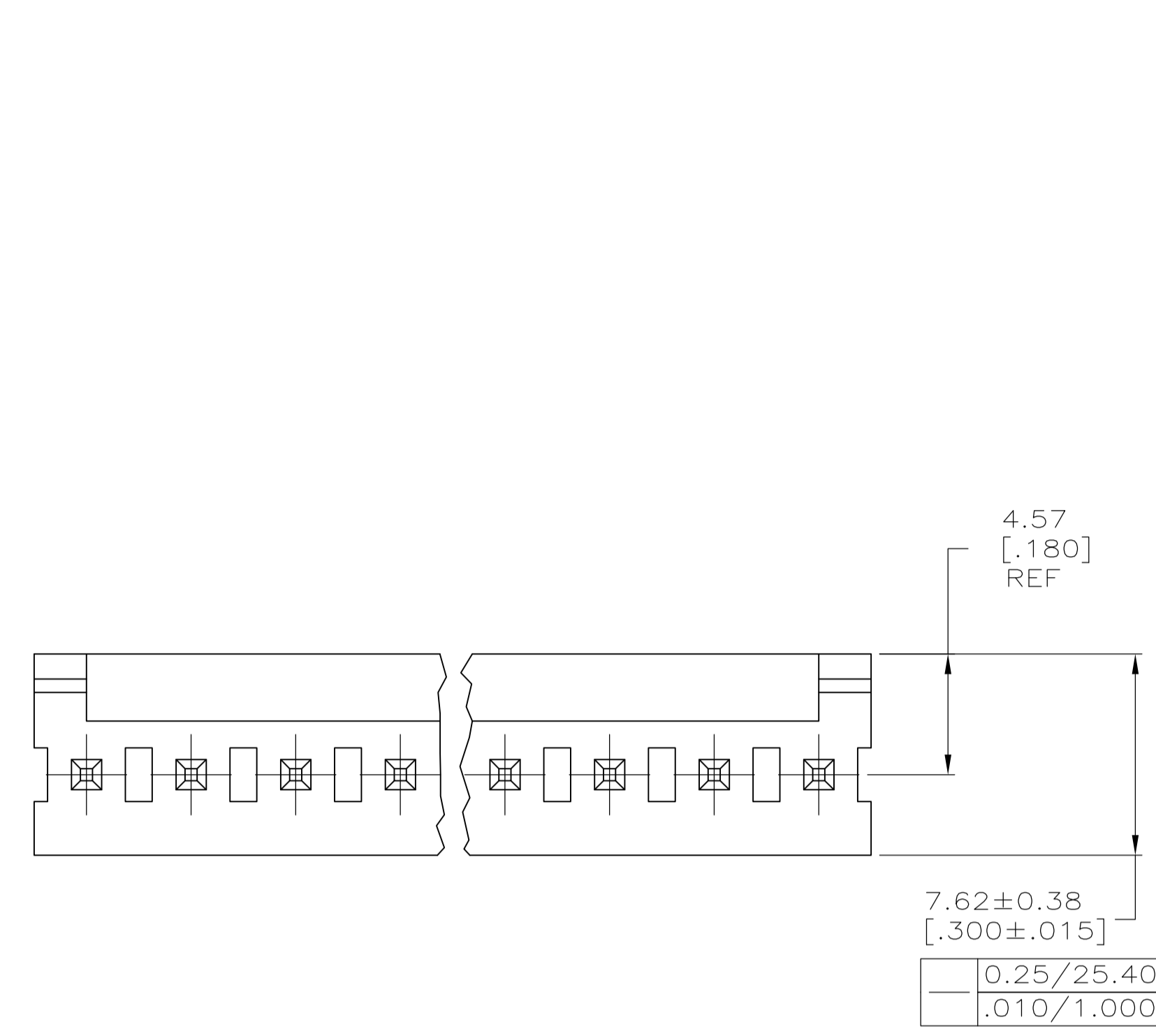
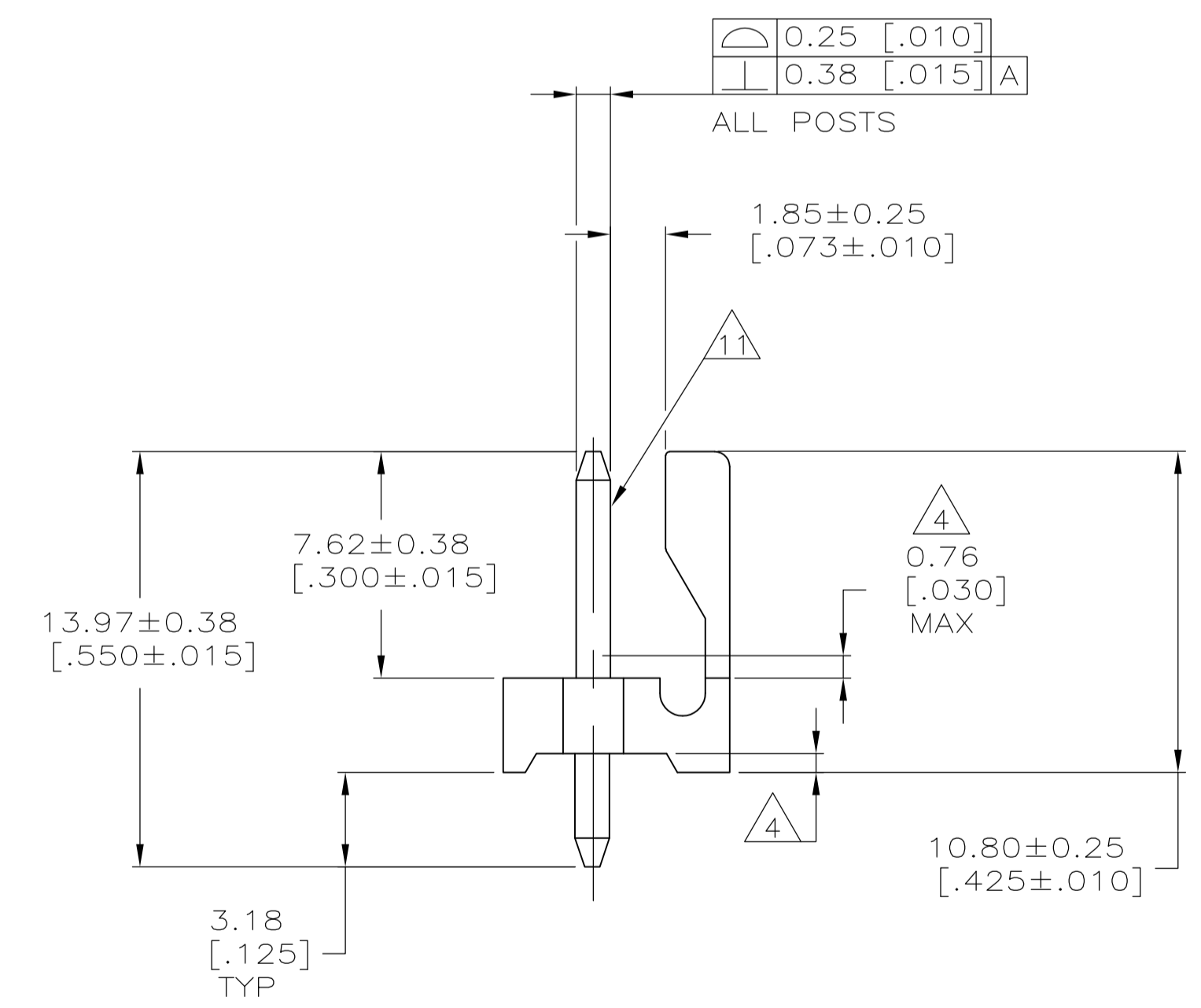
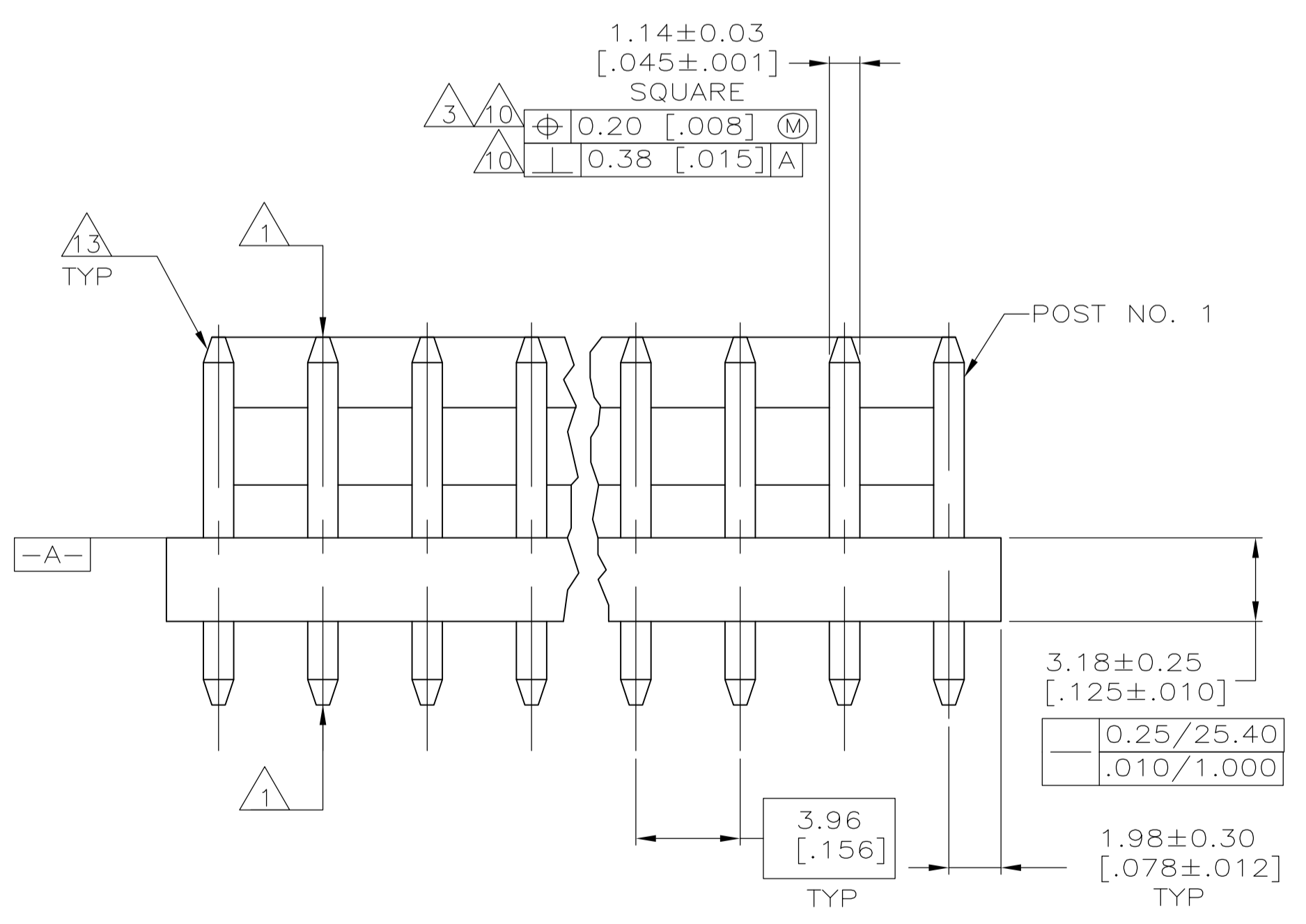

LEAD FREE	23.77 [.936]	6	3-644998-6
	DIM (L)	NO.OF POSN	ASSEMBLY

LEAD FREE	23.77 [.936]	6	644998-6
	DIM (L)	NO.OF POSN	ASSEMBLY

**METRIC**

THIS DRAWING IS A CONTROLLED DOCUMENT.

DIMENSIONS: mm [INCHES]	TOLERANCES UNLESS OTHERWISE SPECIFIED:	0 PLC ± -	1 PLC ± -	2 PLC ± 0.13 [.005]	3 PLC ± -	4 PLC ± -	ANGLES ± -	FINISH 7
-------------------------	--	-----------	-----------	---------------------	-----------	-----------	------------	----------

DMN: S. HOOVER 07NOV02	APVD: D. ROSSI 07NOV02	Tyco Electronics Corporation Harrisburg, PA 17105-3608
CHK: D. ROSSI	NAME: MTA-156 HEADER ASSEMBLY, FRICTION LOCK, STRAIGHT, .045 SQUARE POST, TIN PLATED, SPECIAL	RESTRICTED TO
PRODUCT SPEC	APPLICATION SPEC	SIZE: A1
WEIGHT: -	CAGE CODE: 644998	SCALE: 5:1
CUSTOMER DRAWING	SHEET 1 OF 1	REV D