

Revision level		Revision Record	Changed	Date	Approved	Date
part	drawing					
—	05					

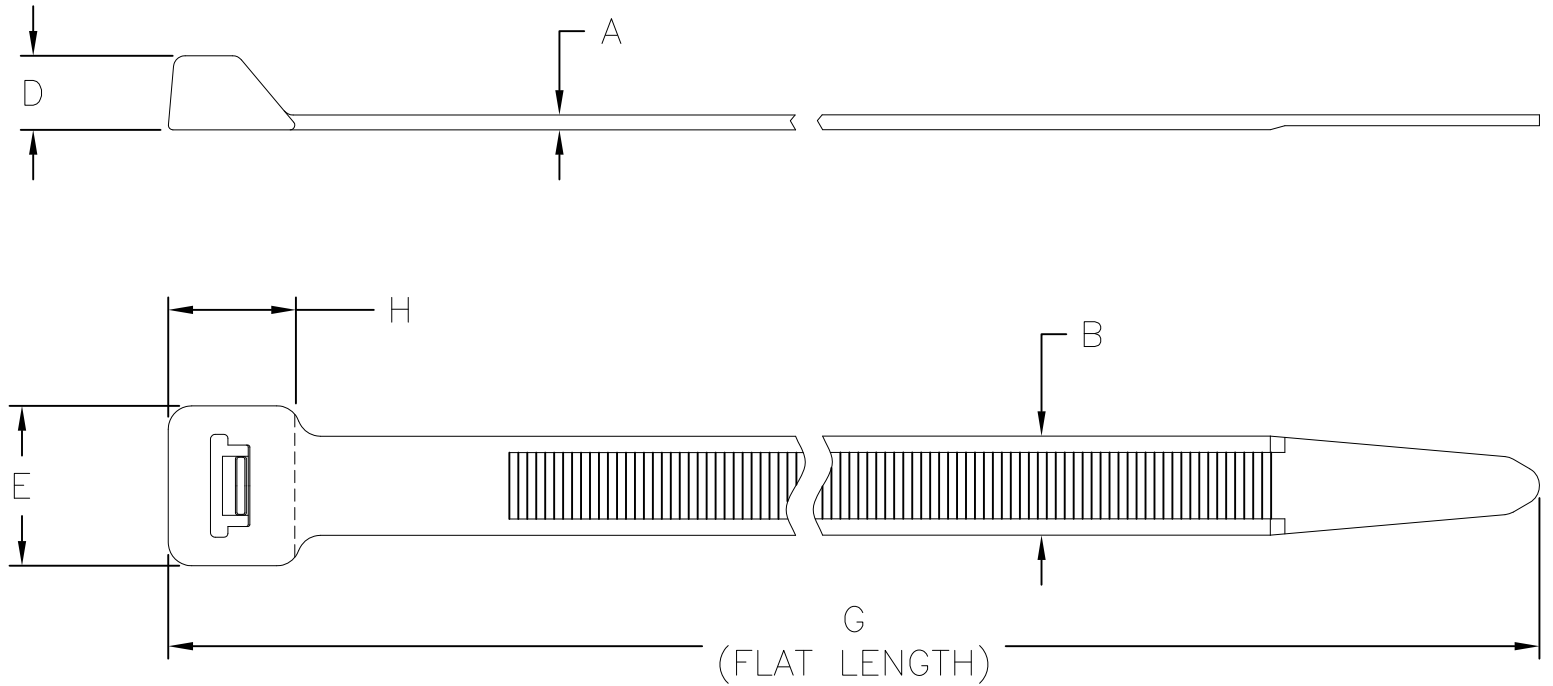

PRODUCT CODE DESCRIPTION

SR255X_HIHSUV
 COLOR
 (CONSULT FACTORY FOR AVAILABLE COLORS)

Type	Cable Range (mm)	Material	A	B	D	E	G	H	Min Loop Tensile Strength (newtons)
SR255X	13 to 100	PA66	1.8±0.2	12.6±0.3	9.3 ±0.3	20.0 ±0.5	370.0 ±10.0	15.5 ±1.2	1115
		PA66HIHSUV							

SEE CHART

Material

Dimension tolerances unless otherwise specified
 .XXX =
 .XXX =
 .XX = NOTED
 .X =
 < =

Dimension Units mm

PERFORMANCE SPECIFICATION

ACAD MECH 2010		Drawn	KDP	02/14/01	Scale	1:1	Computer File Number CT\CST\2252006_05
		Approved	K.A.C.	08/21/12			
ALL PROPRIETARY RIGHTS IN THE SUBJECT MATTER SHOWN ON THIS DRAWING ARE EXCLUSIVE PROPERTY OF HELLERMANN TYTON		HellermannTyton 7930 N. Faulkner Rd. Milwaukee, WI 53224 Ph: (414) 355-1130 Fx: (414) 362-8338			Drawing-No CT2252006CST		Phase: Production
							Format AH
							Sheet 1 of 1