

THIS DRAWING IS UNPUBLISHED. RELEASED FOR PUBLICATION  
 © COPYRIGHT BY TYCO ELECTRONICS CORPORATION. ALL RIGHTS RESERVED.

LOC	DIST	REVISIONS			
P	LTR	DESCRIPTION	DATE	DWN	APVD
CM	0	REVISED PER 0G3B-0237-05	9/20/05	SS	CJ

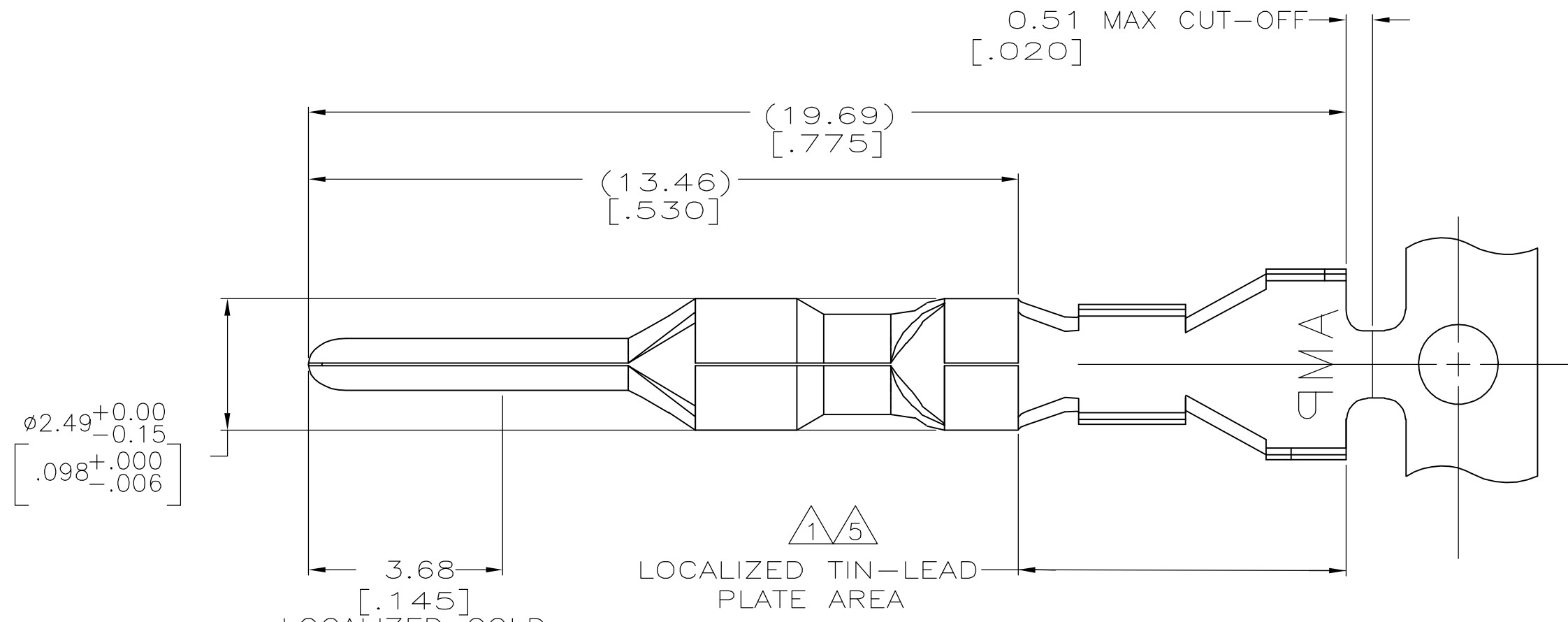

- 1. 0.00076 [.000030] MIN GOLD PER AMP SPEC 112-162-3 IN LOCALIZED GOLD PLATE AREA AND 0.00254-0.00635 [.000100-.000250] BRIGHT TIN-LEAD PER AMP SPEC 112-26-1 IN LOCALIZED TIN-LEAD PLATE AREA OVER 0.00127 [.000050] MIN NICKEL PER AMP SPEC 112-25-2.
- 2. WIRE RANGE: 0.5-1.4MM<sup>2</sup> (20-16 AWG).
- 3. INSULATION RANGE: 2.01-3.20[.079-.126] DIA.
- 4. DIMENSIONS IN BRACKETS ARE IN INCHES.
- 5. 0.00076 [.000030] MIN GOLD PER AMP SPEC 112-162-3 IN LOCALIZED GOLD PLATE AREA AND 0.00254-0.00635 [.000100-.000250] MATTE TIN PER AMP SPEC 112-16-3 IN LOCALIZED TIN PLATE AREA OVER 0.00127 [.000050] MIN NICKEL PER AMP SPEC 112-25-2.

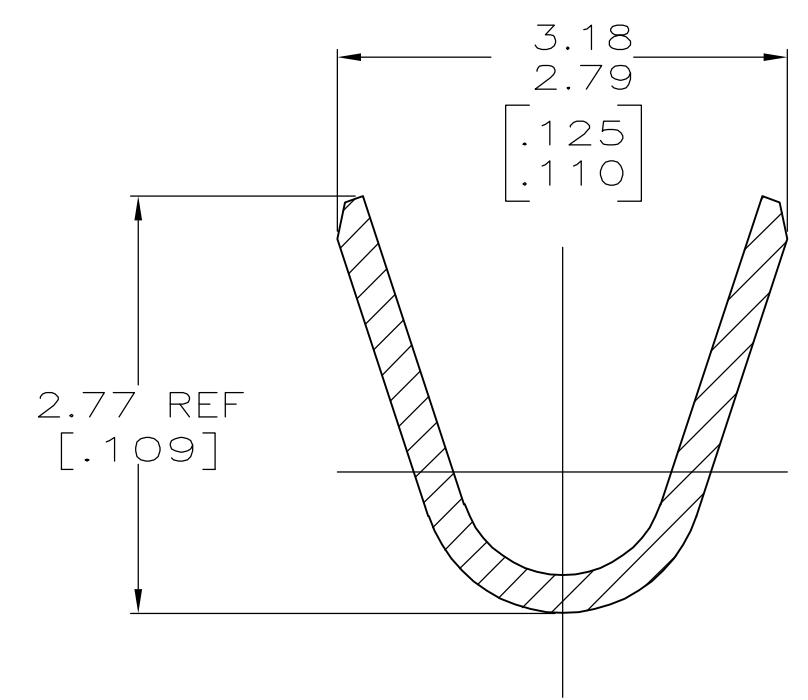
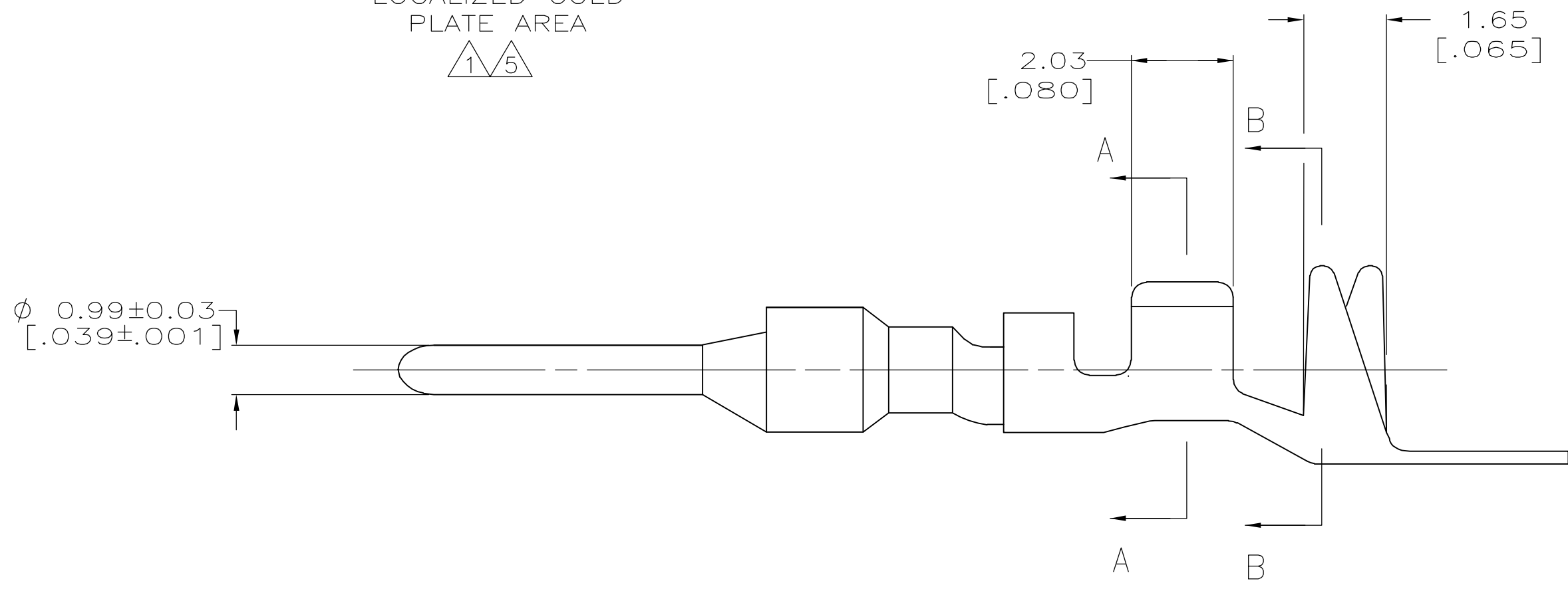

SECTION A-A  
SCALE 20:1

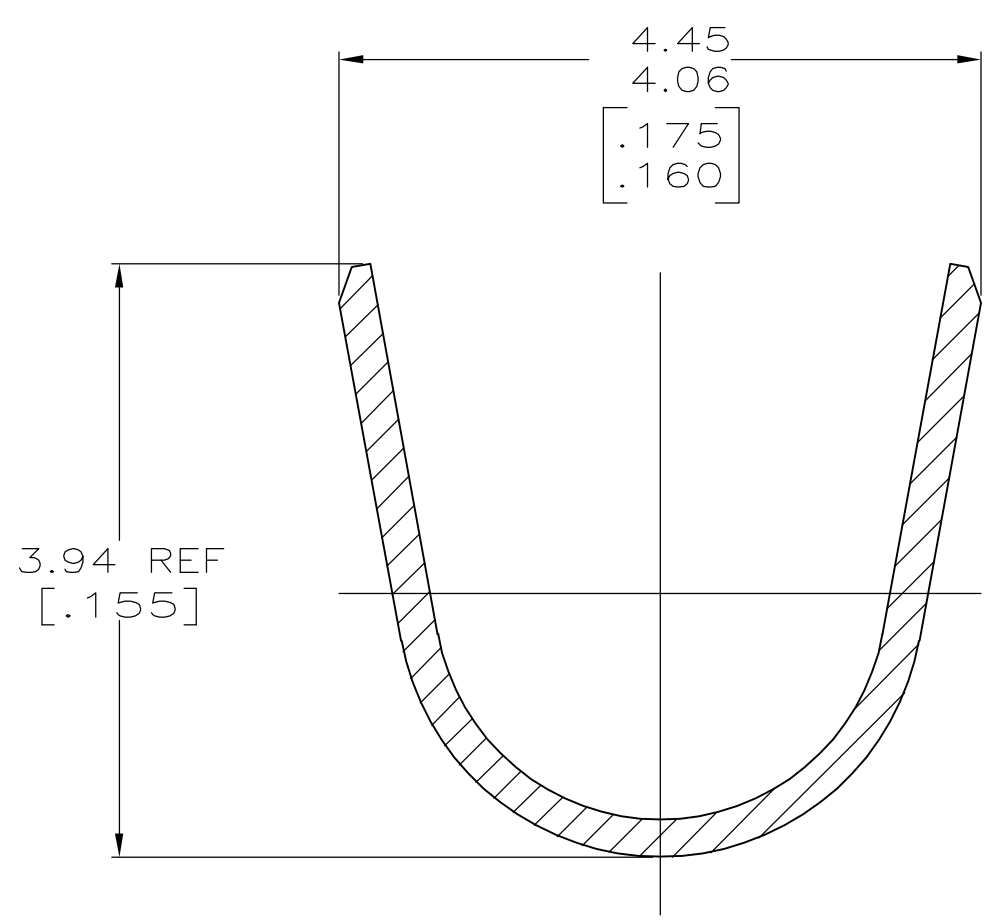

SECTION B-B  
SCALE 20:1

5	0.25[.010] BRASS	1-794222-0
1	0.25[.010] BRASS	794222-3
PRE-TIN	0.25[.010] BRASS	794222-1
FINISH	MATERIAL	PART NUMBER

THIS DRAWING IS A CONTROLLED DOCUMENT.

DWN R. VESTAL 2-20-98	Tyco Electronics Corporation Harrisburg, PA 17105-3608					
CHK R. SWING 2-20-98						
APVD -						
NAME						
DIMENSIONS: mm [INCHES]	PRODUCT SPEC	PIN, MINI UNIVERSAL MATE-N-LOK 2				
TOLERANCES UNLESS OTHERWISE SPECIFIED: 0 PLC ± - 1 PLC ± - 2 PLC ± - 3 PLC ± 0.15 [.006] 4 PLC ± - ANGLES ± -	APPLICATION SPEC					
MATERIAL SEE TABLE	FINISH SEE TABLE	WEIGHT -	SIZE A2	CAGE CODE 00779	DRAWING NO C=794222	RESTRICTED TO -
CUSTOMER DRAWING		SCALE 10:1	SHEET 1 of 1	REV E		