

OPTICAL ISOLATOR

ELECTRONIC MODULES



Introduction

This is a versatile interface between an incremental encoder and receiving electronics. It accepts single ended or differential inputs and provides single ended or differential outputs in either an open collector or line driver configuration. It accommodates all standard operating voltages from 5 to 28 VDC. Up to eight Optical Isolator Modules can be daisy-chained to provide multiple, simultaneous outputs to controllers or PLC's. This Optical Isolator can help clean up noisy signals by converting to a different line driver output. It has a 1 MHz throughput capability and can be used wherever a fast, optically isolated interface is required.

ELECTRICAL SPECIFICATIONS

POWER : The optical isolator can accommodate standard operating voltages from 5 to 28 VDC. It should never be connected directly to AC power mains. The module draws approximately 75 mA and a green LED indicates the unit is powered. The optical isolator module does not provide power to the encoder. Any encoders used in conjunction with this module must be connected to their own power.

SIGNAL : Specifying an optical isolator module requires knowledge of three system parameters: the DC supply voltage available in the system; the encoder output type (logic levels and driver type); and the input signal specifications of the receiving electronics.

MECHANICAL SPECIFICATIONS

Package dimensions are 114.4 mm high by 99 mm wide by 22.5 mm thick. The package mounts to a DIN rail type EN 50 022 (35mm X 7.5mm). A length of DIN rail is supplied with each module. The module simply snaps directly to the DIN rail and is ready to use.

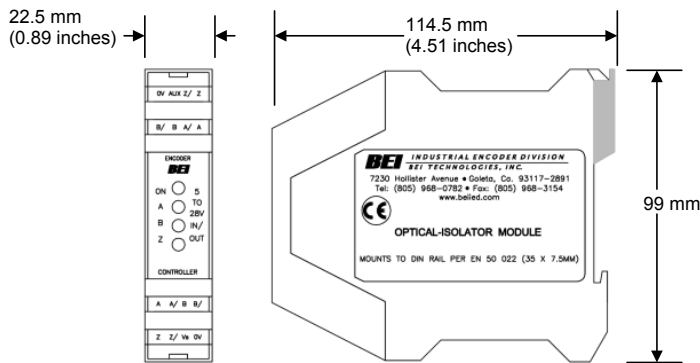

Output Code Format From Encoder	Dual Channel in quadrature with index and complements. Data lines are designated A, B, Z, A/, B/, Z/ at the module
Output Signal Type From Encoder	Differential line driver (Use Connection Instructions #1) Single ended line driver (Use Connection Instructions #2) Single ended open collector with pull-up resistors internal to encoder (Use Connection Instructions #3) Single ended, open collector (Use Connection Instructions #3)
Output Signal Voltage Level From Encoder	5 VDC (TTL, RS422 compatible, line driver) 12-15 VDC 24VDC
Frequency Response of Optical Isolator	1 MHz, maximum
Power Requirements For Optical Isolator	5-28 VDC $\pm 5\%$, 75mA plus load current
Optical Isolator Output Options	28V/V Line Driver, 100mA source/sink, $V_{out} = V_{in}$ 28V/5 Line Driver, 100mA source/sink, $V_{out} = 5V$ (Derate output current to 50mA with supply voltage > 12VDC) 28V/OC NPN Open Collector, 80mA sink
Protection Level	Supply lines protected against over voltage to 60 volts and reverse voltage
Tristate Outputs	Available as -S Special Feature

CONNECTION INSTRUCTIONS #1

Differential Line Driver

Encoder signals from 5 VDC to 24 VDC (must specify the voltage when ordering)

This is the preferred type of encoder output as it has the best noise immunity. Connect each encoder signal to its like optical isolator input (A to A, A/ to A/, etc).

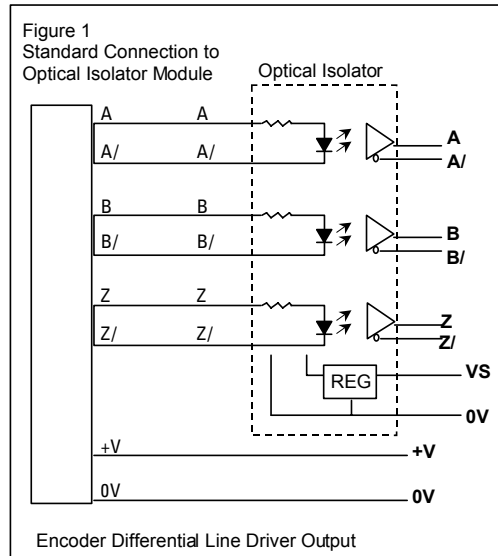
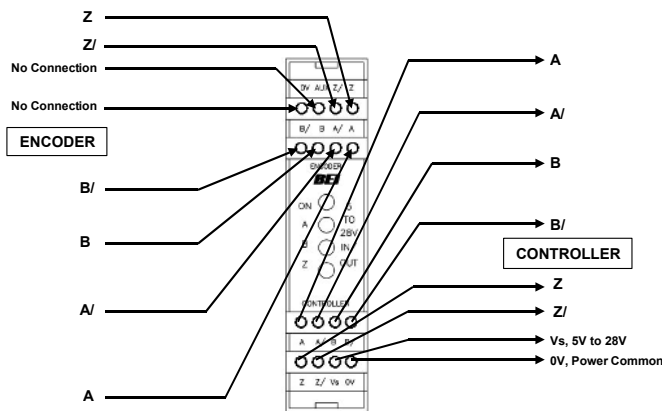

CONNECTION INSTRUCTIONS #2

Single Ended Line Driver

Encoder signal from 5 VDC to 24 VDC (must specify the voltage when ordering)

Connect encoder output A to optical isolator module input channel A, B to B and Z to Z. Connect the A/, B/, and Z/ inputs of the optical isolator to circuit common of the encoder supply. Single ended operation is limited to shorter cable runs and is more susceptible to noise.

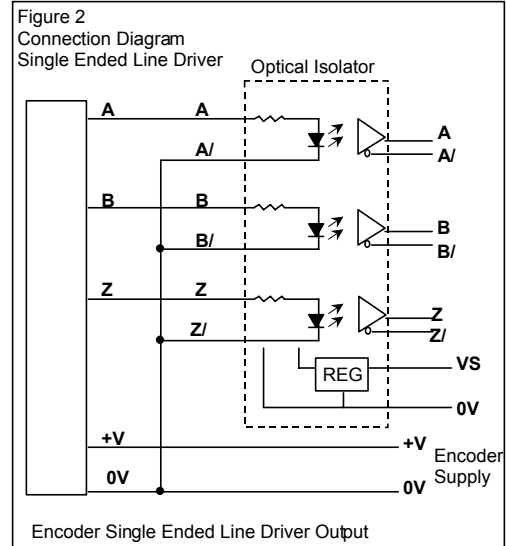
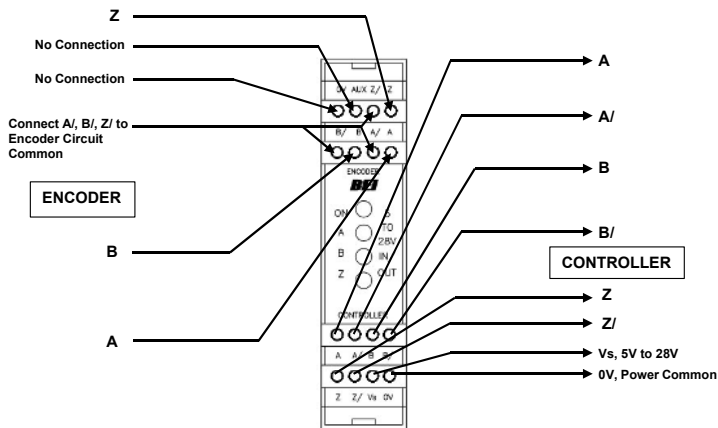

CONNECTION INSTRUCTIONS #3

Open Collector with or without Internal Pull-up Resistors

Encoder NPN (sinking) outputs.

Connect encoder output A to optical isolator module input A/, B to B/ and Z to Z/. Connect the A, B, and Z inputs of the optical isolator to the auxiliary output terminal on the optical isolator module for 5V module and to higher voltage when specified by module model and part number. This connection results in a logic inversion within the optical isolator module. To compensate for the logic reversal, swap A for A/, B for B/, and Z for Z/ at the optical isolator outputs.

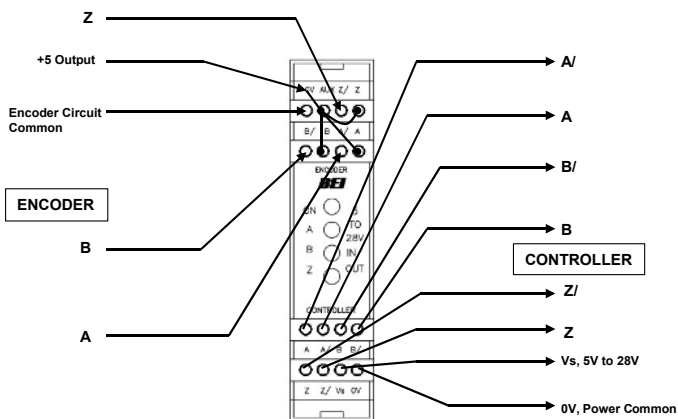

To 5 AUX for 5V module.
To 12-15 for 24V dependent on specified module input voltage.

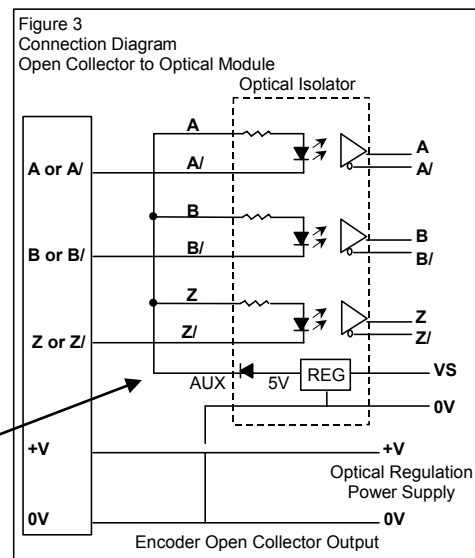



Example 1: Resolve an electrical conflict between encoder output and receiving electronics

Sometimes system constraints result in an incompatibility between the encoder output and the receiving electronics or the cabling. A typical symptom of this problem is missed or intermittent counts. As an example, a single-ended TTL receiver that is more than 20 feet from the encoder may not be able to compensate for the signal attenuation and ringing caused by the encoder cabling. An optical isolator module installed near the receiver as shown in Figure 4 can receive the signal, rejecting the cable effects and produce a signal compatible with the input device.

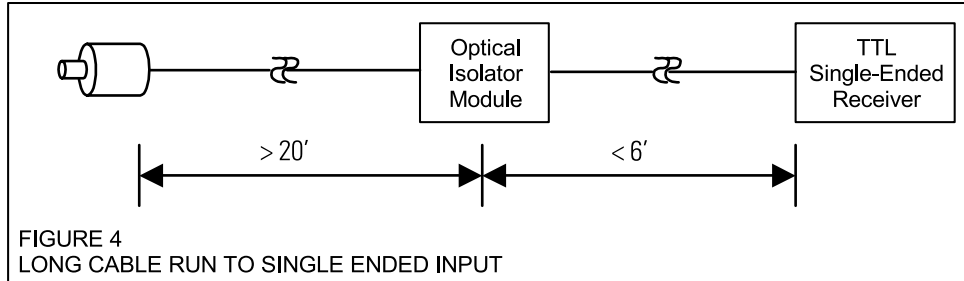

Example 2: Signal Splitter

The optical isolator can be used to connect a single encoder to multiple devices. Optical isolator can be used to split an encoder output to drive up the 8 devices as shown in Figure 5. One optical isolator module is used to drive each receiver. Optical isolator modules can be specified with outputs to match receiver inputs; i.e. an encoder signal can be split to drive a differential TTL input with one module, a 12 V line driver with another module and provide an open collector, NPN signal with another module.

* Also see the BEI Encoder Signal Broadcaster Module on page 5 for this application*

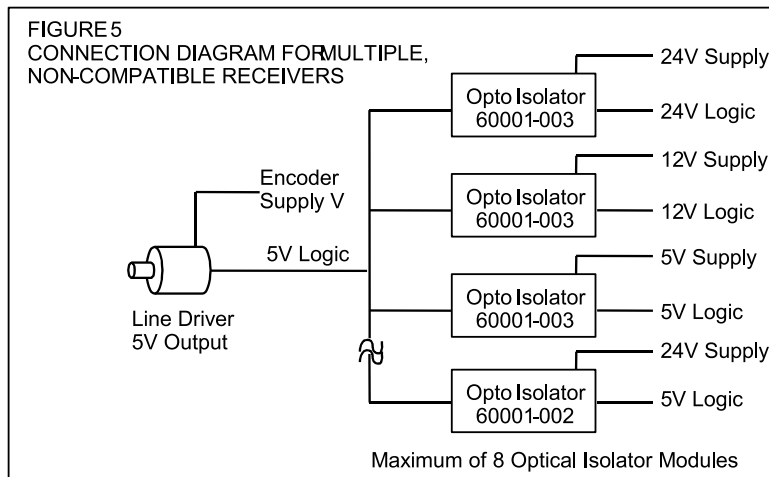

Example 3: Repeater

On extremely long cable runs (greater than 500 feet), an optical isolator module may be needed as a midpoint repeater to receive, amplify and re-broadcast the signal. An example is illustrated in Figure 6.

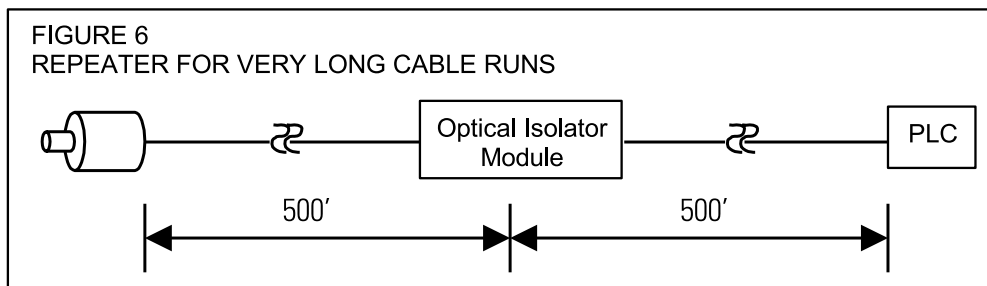

OPTICAL ISOLATOR SELECTION TABLE

To find the correct optical isolator for your application, look in column 1 for the logic voltage of your encoder. Then choose the correct row in column 2 that describes the type of output from the isolator that is compatible with your receiving electronics. Read across to columns 3 and 4 to find the module and part number of the correct optical isolator.

(1) Encoder Output Logic Level Voltage	(2) Optical Isolator Output Logic Level Voltage	(3) Model Number	(4) Part Number
5V	Vout = Vin	EM-DR1-IC-5-TB-28V/V	60001-003
	Vout = 5V	EM-DR1-IC-5-TB-28V/5	60001-002
	Vout = OC	EM-DR1-IC-5-TB-28V/OC	60001-004
12-15 VDC	Vout = Vin	EM-DR1-IC-15-TB-28V/V	60001-008
	Vout = 5V	EM-DR1-IC-15-TB-28V/5	60001-012
	Vout = OC	EM-DR1-IC-15-TB-28V/OC	60001-014
24 VDC	Vout = Vin	EM-DR1-IC-24-TB-28V/V	60001-010
	Vout = 5V	EM-DR1-IC-24-TB-28V/5	60001-011
	Vout = OC	EM-DR1-IC-24-TB-28V/OC	60001-013

ADDITIONAL MODULES AND ACCESSORIES

Encoder Signal Broadcaster Module

Accepts standard incremental encoder inputs and can broadcast up to four encoder signals to four independent devices. Each of the broadcast signals are optically isolated eliminating ground loops.

Power Supply

With a wide range of acceptable input voltages (AC and DC) this DIN Rail mountable power supply is usable in virtually all industrial applications worldwide. It has built in surge protection to reduce faults due to transients and it has 100% reserve capacity for startup and overload conditions.

Cable And Cable Assemblies

Cable reels for your own custom wiring requirements or cable assemblies are available, using high quality custom BEI standard cable consisting of four, low capacitance shielded twisted pairs with an overall shield, extra large conductors for power, and signal ground; all within an abrasion-resistant PVC jacket.

Cable Reels

100 ft. reel Part No. 37048-003-100

500 ft. reel Part No. 37048-003-500

Cable Assemblies

Part Nos. for MS3106F14S-6S Mating Connector

10 ft. # 31186-1410 | 20 ft. # 31186-1420 | 30ft. # 31186-1430

Part Nos. for MS3106F16S-1S Mating Connector

10 ft. # 31186-1610 | 20 ft. # 31186-1620 | 30ft. # 31186-1630

Part Nos. for MS3106F18S-1S Mating Connector

10 ft. # 31186-1810 | 20 ft. # 31186-1820 | 30ft. # 31186-1830





AGENCY APPROVALS & CERTIFICATIONS



Made In France

Page 6

Sensata Technologies, Inc. ("Sensata") data sheets are solely intended to assist designers ("Buyers") who are developing systems that incorporate Sensata products (also referred to herein as "components"). Buyer understands and agrees that Buyer remains responsible for using its independent analysis, evaluation and judgment in designing Buyer's systems and products. Sensata data sheets have been created using standard laboratory conditions and engineering practices. Sensata has not conducted any testing other than that specifically described in the published documentation for a particular data sheet. Sensata may make corrections, enhancements, improvements and other changes to its data sheets or components without notice.

Buyers are authorized to use Sensata data sheets with the Sensata component(s) identified in each particular data sheet. HOWEVER, NO OTHER LICENSE, EXPRESS OR IMPLIED, BY ESTOPPEL OR OTHERWISE TO ANY OTHER SENSATA INTELLECTUAL PROPERTY RIGHT, AND NO LICENSE TO ANY THIRD PARTY TECHNOLOGY OR INTELLECTUAL PROPERTY RIGHT, IS GRANTED HEREIN. SENSATA DATA SHEETS ARE PROVIDED "AS IS". SENSATA MAKES NO WARRANTIES OR REPRESENTATIONS WITH REGARD TO THE DATA SHEETS OR USE OF THE DATA SHEETS, EXPRESS, IMPLIED OR STATUTORY, INCLUDING ACCURACY OR COMPLETENESS. SENSATA DISCLAIMS ANY WARRANTY OF TITLE AND ANY IMPLIED WARRANTIES OF MERCHANTABILITY, FITNESS FOR A PARTICULAR PURPOSE, QUIET ENJOYMENT, QUIET POSSESSION, AND NON-INFRINGEMENT OF ANY THIRD PARTY INTELLECTUAL PROPERTY RIGHTS WITH REGARD TO SENSATA DATA SHEETS OR USE THEREOF.

All products are sold subject to Sensata's terms and conditions of sale supplied at www.sensata.com SENSATA ASSUMES NO LIABILITY FOR APPLICATIONS ASSISTANCE OR THE DESIGN OF BUYERS' PRODUCTS. BUYER ACKNOWLEDGES AND AGREES THAT IT IS SOLELY RESPONSIBLE FOR COMPLIANCE WITH ALL LEGAL, REGULATORY AND SAFETY-RELATED REQUIREMENTS CONCERNING ITS PRODUCTS, AND ANY USE OF SENSATA COMPONENTS IN ITS APPLICATIONS, NOTWITHSTANDING ANY APPLICATIONS-RELATED INFORMATION OR SUPPORT THAT MAY BE PROVIDED BY SENSATA.

Mailing Address: Sensata Technologies, Inc., 529 Pleasant Street, Attleboro, MA 02703, USA.

CONTACT US

Americas

+1 (800) 350 2727

sales.beisensors@sensata.com

Europe, Middle East & Africa

+33 (3) 88 20 8080

position-info.eu@sensata.com

Asia Pacific

sales.isasia@list.sensata.com

China +86 (21) 2306 1500

Japan +81 (45) 277 7117

Korea +82 (31) 601 2004

India +91 (80) 67920890

Rest of Asia +886 (2) 27602006
ext 2808