

UNIT:MM

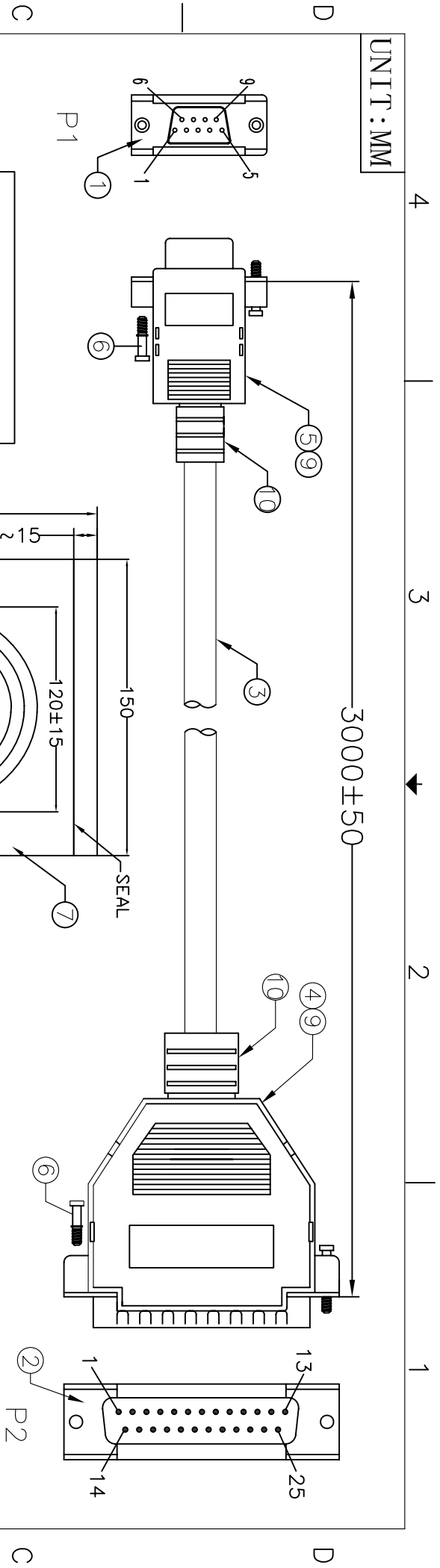

Electronic Test:

1. 100% Test,(Open,Short,Miss Wire)
- 2.Contact Resistance:5 ohm max.
- 3.Insulation Resistance:5M ohm min.
- 4.Hi-Pot:300V DC.

P1		P2	
1	BLACK	4	
2	BROWN	2	
3	RED	3	
4	ORANGE	6,5	
5	YELLOW	7	
6,8	GREEN	20	
7	BLUE	8	
	DRAIN		
	SHELL		

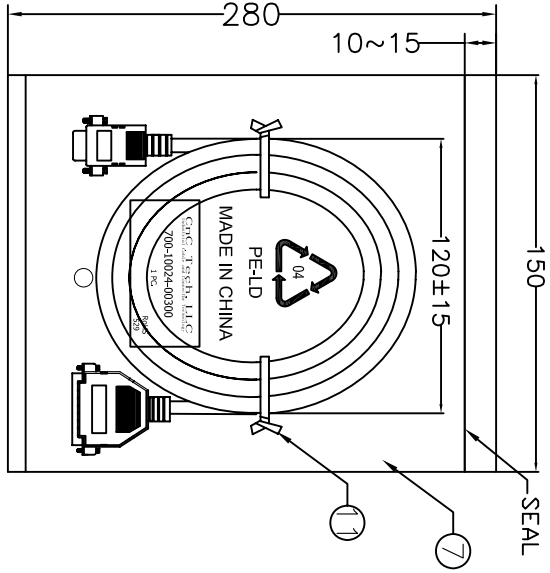

①	TIE	2	WHITE L=100mm
⑩	S/R	5.5g	BEIGE(IV-29#) 45P PVC (MOULD NO.SR-50/SR-51)
⑨	TUBE	50mm	HEAT SHRINK TUBE BLACK OD1.5mm,L1=20mm,L2=30mm
⑧	PE BAG	1/10	CLEAR SIZE: 360*380*0.05mm PRINT BLACK"MADE IN CHINA"+"10PCS"及生产日期,有透气孔.
⑦	PE BAG	1	CLEAR SIZE: 150*280*0.05mm PRINT BLACK"MADE IN CHINA"+"1PC"及生产日期,有透气孔.
⑥	SCREW	4	SCREW #4-40UNC L=12.5mm,NICKEL PLATED
⑤	DKN	1	DB9P DKN W/O NUT BEIGE
④	DKN	1	DB25P DKN W/O NUT BEIGE
③	CABLE	1	NOUL 28AWG(7/0.12)*7C+D+AL OD5.0mm COLOR BEIGE(IV-29#) L=3000±15mm
②	CONN	1	DB25P MALE SOLDER TYPE PIN G/F, BLUE INSULATION
①	CONN	1	DB 9P FEMALE SOLDER TYPE G/F, BLUE INSULATION
NO.	NAME	QTY	

SPECIFICATION

CNC Tech, LLC

Industrial Cable and Connector Technology

DRAWN BY	ZHONGHS	DRAWING NO.	
CHECKED BY		CUSTOMER	
APPROVAL BY		ITEM NO.	700-10024-00300
DECIDE BY		DATE	2012-02-06
VERSIONS/EDIT/TECH	A/0	PROJECT	