

REVISIONS

P	LTR	DESCRIPTION	DATE	DWN	APVD
	A2	REVISED PER ECN-21-122181	26OCT2021	RZ	WK

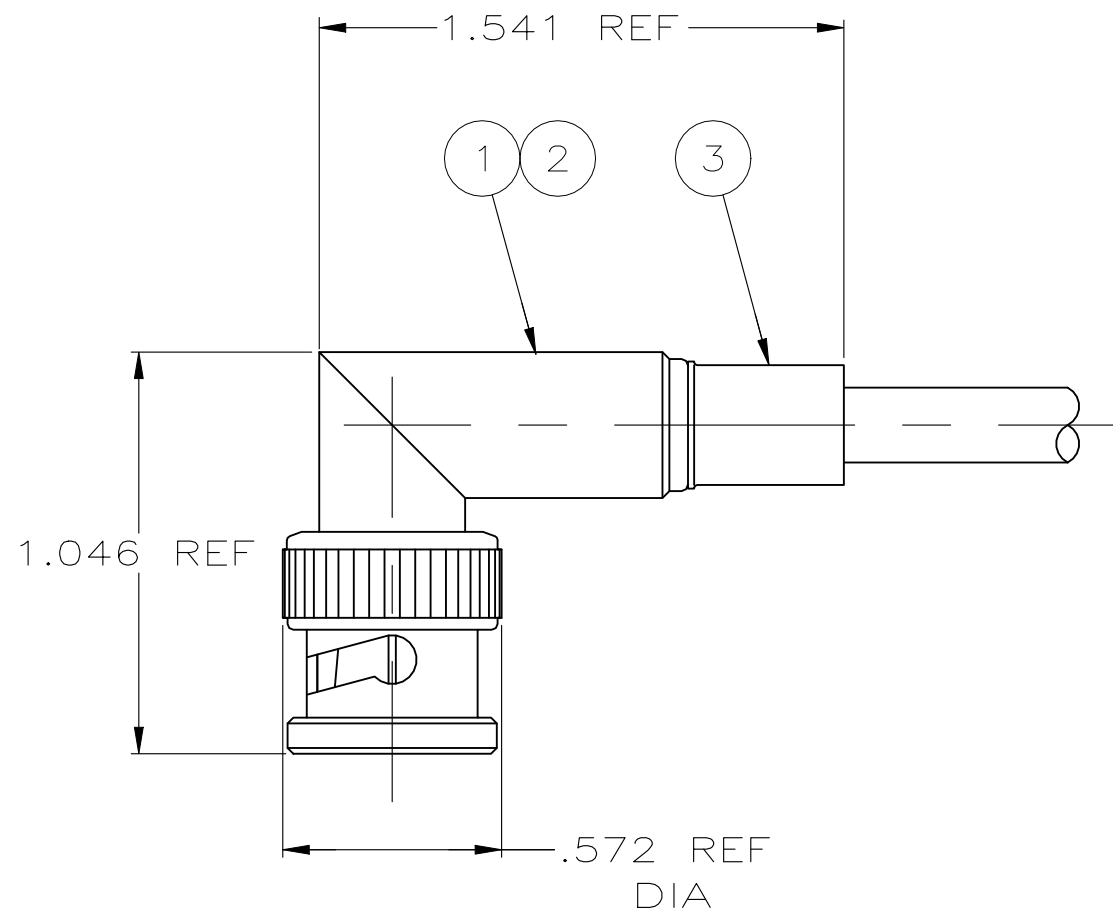

1. USE HAND TOOL 69478-1.
2. SEE INSTRUCTION SHEET 408-1914-5.

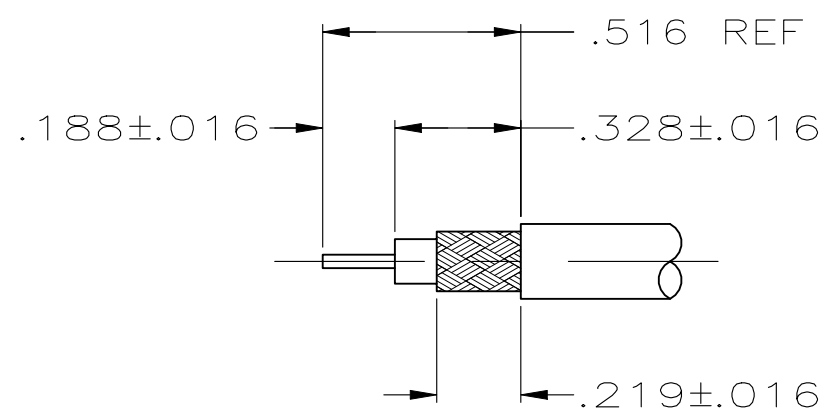

RECOMMENDED STRIP LENGTH

RG 142/U, 142A/U, & 142B/U	9-225382-1	1-331369-2	225975-1	5225973-4
RG 58/U, 58A/U, 58B/U, & 58C/U	9-225381-1	331369	225975-1	5225973-1
CABLE	③ FERRULE QTY=1	② CONTACT QTY=1	① PLUG ASSY QTY=1	PART NUMBER

THIS DRAWING IS A CONTROLLED DOCUMENT.		DWN J. HAVENER 27JUL2005	STE TE Connectivity		
DIMENSIONS: INCHES		CHK J. HAVENER 27JUL2005			
TOLERANCES UNLESS OTHERWISE SPECIFIED:		APVD J. LIPPERT 27JUL2005	NAME PLUG, RIGHT ANGLE DUAL CRIMP, BNC		
0 PLC ± -		PRODUCT SPEC 108-12020	-		
1 PLC ± -		APPLICATION SPEC -	SIZE A3	CAGE CODE 00779	DRAWING NO C-5225973
2 PLC ± -		RESTRICTED TO -	SCALE 2:1		
3 PLC ± -		WEIGHT 0.000000	SHEET 1 OF 1		
4 PLC ± -		CUSTOMER DRAWING	REV A2		
ANGLES ± -					
FINISH -					