

P	LTR	DESCRIPTION	DATE	DWN	APVD
	C3	REVISED PER ECN-22-146347	05APR2022	RZ	WK

	-	9.50	19.40	6.00	6.70	8.70	10.00	10.50	CT125	5-1814821-7
OBSOLETE	-	9.50	19.40	6.00	6.70	8.70	10.00	10.50	CT125	5-1814821-6
OBSOLETE	9-1478243-0	8.50	19.40	4.85	5.70	7.70	9.00	9.50	CT100	5-1814821-5
OBSOLETE	9-1478243-0	8.50	19.40	4.85	5.70	7.70	9.00	9.50	CT100	5-1814821-4
	1583581-1	10.20	19.40	4.85	5.50	9.50	10.80	11.20	RG6/U	5-1814821-3
OBSOLETE	1583581-1	10.20	19.40	4.85	5.50	9.50	10.80	11.20	RG6/U	5-1814821-2
	9-1478243-0	8.50	20.40	3.90	4.70	7.50	9.00	9.50	RG59B/U, 62A/U, 140/U, 210/U, URM90, Belden 9291, 9291, KX6A, KX25, KX52, KX53	5-1814821-1
OBSOLETE	9-1478243-0	8.50	20.40	3.90	4.70	7.50	9.00	9.50	RG59B/U, 62A/U, 140/U, 210/U, URM90, Belden 9291, 9291, KX6A, KX25, KX52, KX53	5-1814821-0
	DIE SET	G	F	E	D	C	B	A	CABLE GROUPS	PART NO.
DIMENSIONS										

NOTES

- 1 SINGLE PACK IN ACCORDANCE WITH AMP SPEC 107-3275
- 2 100 TRAY PACK IN ACCORDANCE WITH AMP SPEC 107-3275
- 3 Ni PLATING
- 4. HAND TOOL: 9-1478240-0
- 5. FOR TECHNICAL DATA REFER TO YOUR LOCAL TE CONNECTIVITY SALES OFFICE
- 6. ALL DIMENSIONS ARE NOMINAL FOR REFERENCE ONLY UNLESS OTHERWISE STATED

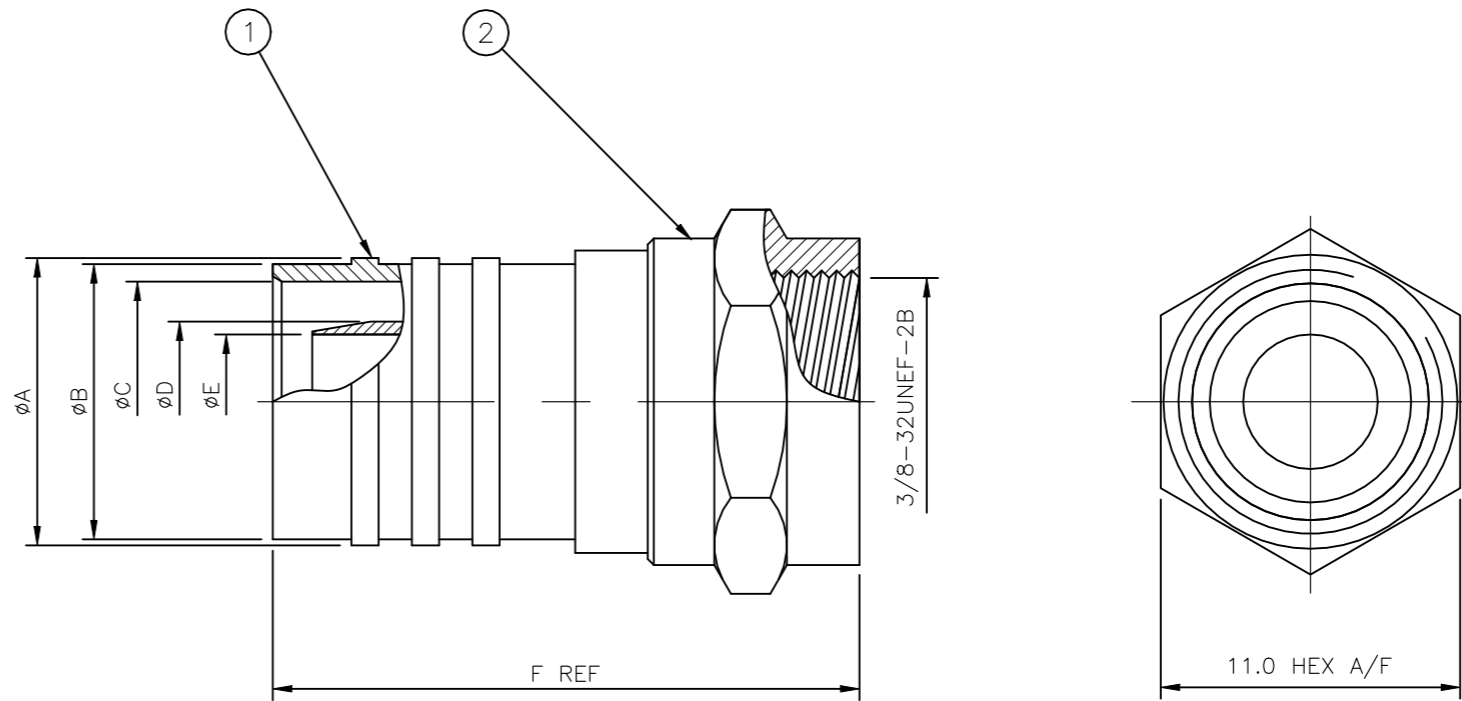

RECOMMENDED CABLE STRIPPING DIM'S

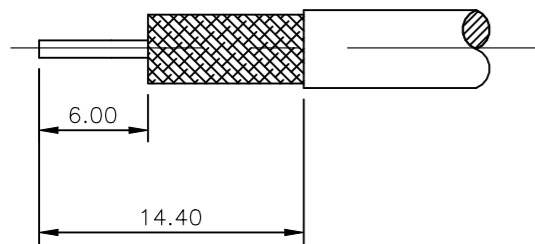

RECOMMENDED CRIMP OUTER FERRULE A/F HEX

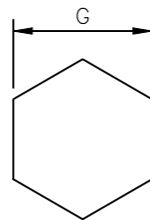

	OBSOLETE	OBSOLETE	OBSOLETE	OBSOLETE	OBSOLETE	OBSOLETE	OBSOLETE				
1	1	1	1	1	1	1	1	ZINC ALLOY	△	COUPLING NUT	2
1	1	1	1	1	1	1	1	BRASS	△	BODY	1
5	75	65	55	45	35	25	15	MATERIAL		DESCRIPTION	ITEM
△	△	△	△	△	△	△	△				
QUANTITY PER ASSY								PARTS LIST			

THIS DRAWING IS A CONTROLLED DOCUMENT.

DWN ANSON MA 14FEB09
 CHK RITA ZUO 14FEB09
 APVD BOB ZHAO 14FEB09

STE TE Connectivity

NAME: F TYPE STRAIGHT PLUG HEX CRIMP

PRODUCT SPEC: 108-112000

APPLICATION SPEC: -

SIZE: - CAGE CODE: A300779 DRAWING NO: C-1814821 RESTRICTED TO: -

WEIGHT: 0.000000

CUSTOMER DRAWING SCALE: NTS SHEET: 1 OF 1 REV: C3