



Is Now Part of



**ON Semiconductor®**

To learn more about ON Semiconductor, please visit our website at  
[www.onsemi.com](http://www.onsemi.com)

Please note: As part of the Fairchild Semiconductor integration, some of the Fairchild orderable part numbers will need to change in order to meet ON Semiconductor's system requirements. Since the ON Semiconductor product management systems do not have the ability to manage part nomenclature that utilizes an underscore (\_), the underscore (\_) in the Fairchild part numbers will be changed to a dash (-). This document may contain device numbers with an underscore (\_). Please check the ON Semiconductor website to verify the updated device numbers. The most current and up-to-date ordering information can be found at [www.onsemi.com](http://www.onsemi.com). Please email any questions regarding the system integration to [Fairchild\\_questions@onsemi.com](mailto:Fairchild_questions@onsemi.com).

ON Semiconductor and the ON Semiconductor logo are trademarks of Semiconductor Components Industries, LLC dba ON Semiconductor or its subsidiaries in the United States and/or other countries. ON Semiconductor owns the rights to a number of patents, trademarks, copyrights, trade secrets, and other intellectual property. A listing of ON Semiconductor's product/patent coverage may be accessed at [www.onsemi.com/site/pdf/Patent-Marking.pdf](http://www.onsemi.com/site/pdf/Patent-Marking.pdf). ON Semiconductor reserves the right to make changes without further notice to any products herein. ON Semiconductor makes no warranty, representation or guarantee regarding the suitability of its products for any particular purpose, nor does ON Semiconductor assume any liability arising out of the application or use of any product or circuit, and specifically disclaims any and all liability, including without limitation special, consequential or incidental damages. Buyer is responsible for its products and applications using ON Semiconductor products, including compliance with all laws, regulations and safety requirements or standards, regardless of any support or applications information provided by ON Semiconductor. "Typical" parameters which may be provided in ON Semiconductor data sheets and/or specifications can and do vary in different applications and actual performance may vary over time. All operating parameters, including "Typicals" must be validated for each customer application by customer's technical experts. ON Semiconductor does not convey any license under its patent rights nor the rights of others. ON Semiconductor products are not designed, intended, or authorized for use as a critical component in life support systems or any FDA Class 3 medical devices or medical devices with a same or similar classification in a foreign jurisdiction or any devices intended for implantation in the human body. Should Buyer purchase or use ON Semiconductor products for any such unintended or unauthorized application, Buyer shall indemnify and hold ON Semiconductor and its officers, employees, subsidiaries, affiliates, and distributors harmless against all claims, costs, damages, and expenses, and reasonable attorney fees arising out of, directly or indirectly, any claim of personal injury or death associated with such unintended or unauthorized use, even if such claim alleges that ON Semiconductor was negligent regarding the design or manufacture of the part. ON Semiconductor is an Equal Opportunity/Affirmative Action Employer. This literature is subject to all applicable copyright laws and is not for resale in any manner.



# FSA8069

## Audio Jack IC Featuring Impedance and Moisture Detection

### Features

- Detection:
  - Accessory Plug-In
  - Send / End Key Press
  - Impedance Detection
  - Prevents False Detection due to Moisture
- $V_{DD}$ : 3.0 V to 4.5 V
- $V_{IO}$ : 1.6 V to  $V_{DD}$
- THD (MIC): 0.01% Typical
- 15 kV Air Gap ESD
- Detects 7 Steps of Headset Impedance
- Integrates LDO for MIC Bias Circuit
- MIC Switch Removes Audio Jack “Pop” and “Click” Caused by MIC Bias

### Description

The FSA8069 is an audio jack detection switch for 3.5 mm and 2.5 mm headsets. The FSA8069 features impedance detection and moisture sensing, which prevents false detection of accessories in the audio jack. An integrated MIC switch allows a processor to configure attached accessories. An LDO provides DC bias to microphone and remote key circuit in accessory. The FSA8069 detects seven headset impedance steps and supports configurable gain in the amplifier according to the type of load. The architecture is designed to allow headphones to be used for listening to music from mobile handsets, personal media players, and portable peripheral devices.

### Applications

- Any Device with 3.5 mm and 2.5 mm Audio Jack
- Cellular Phones, Smart Phones, and Tablets
- MP3, GPS, and PMP

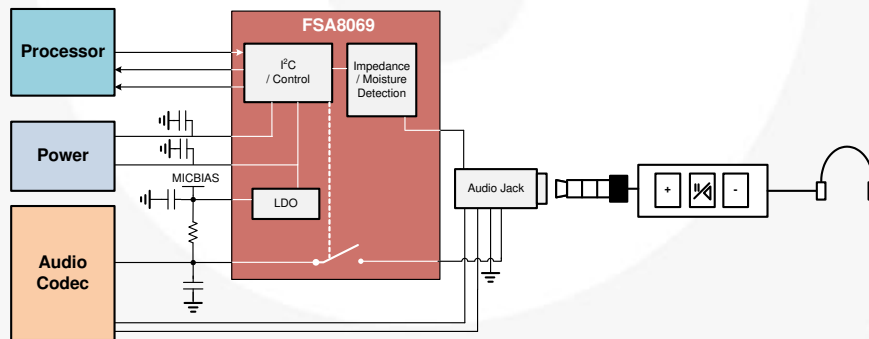


Figure 1. Block Diagram

### Ordering Information

Part Number	Operating Temperature Range	Top Mark	Package	Packing Method
FSA8069UCX <sup>(1)</sup>	-40°C to 85°C	MX	12-Ball WLCSP, 1.415 mm x 1.615 mm, 0.4 mm Pitch	Tape & Reel

#### Notes:

1. Includes backside lamination.

## Typical Application Diagram

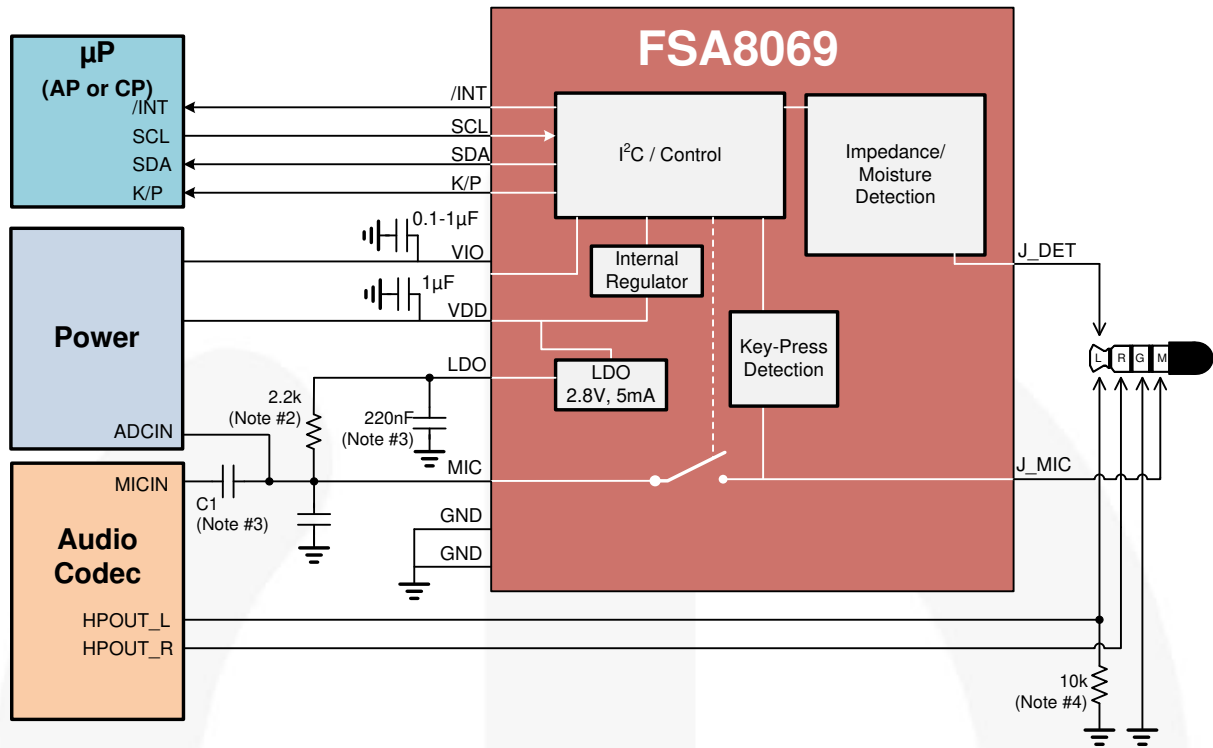


Figure 2. System Diagram

### Notes:

2. 2.2 kΩ can generally be used in applications to bias the accessory microphone. Two separate resistors totaling 2.2 kΩ with a large capacitor between them can improve noise rejection performance, as shown in Figure 7.
3. A DC-blocking capacitor (typically 1 μF) should be used when the codec requires AC-coupled input only. This capacitor can be removed and be tied to directly without C1 if the MICIN of the codec supports DC-coupled input.
4. A pull-down resistor allows the FSA8069 to detect Hi-Z (open cable) type accessories due to J\_DET contact to left when an accessory is inserted.

## Pin Configuration

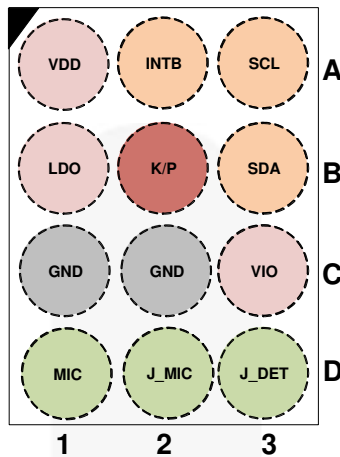


Figure 3. Pin Assignment (Through View)

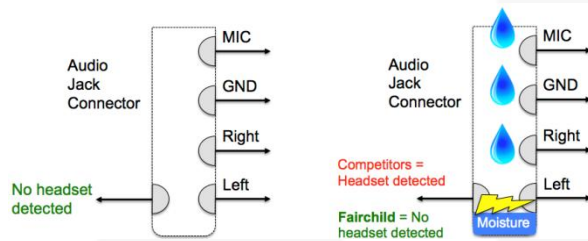
## Pin Definitions

Name	Pin #	Type	Description
VDD	A1	Power	Device supply (3.0 V to 4.5 V)
VIO	C3	Power	I/O supply (1.6 V to V <sub>DD</sub> )
LDO	B1	Power	LDO output (2.8 V)
J_DET	D3	Detection Input	Input from the audio jack; plug insert / removal detection pin
MIC	D1	Signal Path	Microphone switch path that connects to the microphone input of the codec
J_MIC	D2	Signal Path	Microphone switch path that connects to the audio jack
SDA	B3	DATA	I <sup>2</sup> C data
SCL	A3	DATA	I <sup>2</sup> C clock
INTB	A2	Output	Interrupt output LOW: interrupt is asserted (active) HIGH: interrupt is not asserted
K/P	B2	Output	Indicates state of headset key for a 4-pole jack when a key is being pressed HIGH: Key is being pressed LOW: Key is not being pressed
GND	C1, C2	Power	Device ground

## Application Information

### Moisture Detection

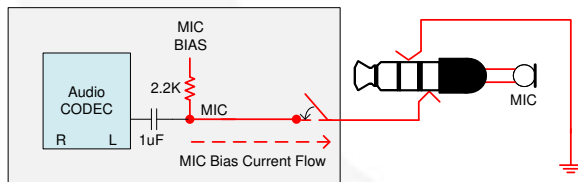
Moisture in the audio jack can cause the phone to incorrectly route audio signals to the audio jack rather than the phone speaker or microphone. Users perceive this as a dropped call or muted phone. The FSA8069 protects against this type of false plug insertion notification and asserts a Moisture Change interrupt in Interrupt1 (0x04h) Register.



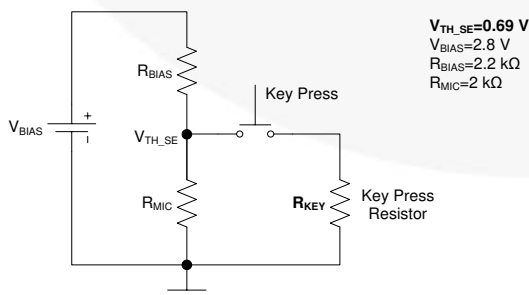
**Figure 4. Moisture Impedance Detection**

### Music Mode

When a 4-pole headset is inserted into the audio jack and a music/listening application is used, the MIC bias is normally enabled for headset button press detection (i.e. mute, volume change, etc.). This consumes power due to a constant path from the MIC bias resistor and microphone in the headset to GND. Fairchild has developed a Music Mode to enable the MIC switch periodically to monitor for a pressed button. This results in a power savings for battery-sensitive devices, such as cell phones or MP3 players. The FSA8069 enters Music Mode when the Music Mode Enable bit in CONTROL(02h) is set and a plug is inserted. Music Mode reduces MIC bias current by approximately 90% with the default Music Mode timing (0Bh) register value.



**Figure 5. MIC Bias Leakage Path**



**Figure 6. Example Key-Press Resistor Calculations and Values**

### Headset Impedance Detection Range

FSA8069 detects jack insertion and removal by monitoring impedance on the J\_DET pin. The accessory types is updated in the Status (03H) register.

**Table 1. Impedance Detection Range**

Accessory Type	Impedance Step	Target Range [Ω]
Headset #1	Step 0	0 to 24
Headset #2	Step 1	24 to 42
Headset #3	Step 2	42 to 100
Headset #4	Step 3	100 to 200
Headset #5	Step 4	200 to 450
Headset #6	Step 5	450 to 1,000
Line_In/Out (CarKit)	Step 6	1000 to 15,000

### LDO Operation

The integrated microphone bias LDO is set to 2.8 V. The LDO can be used to bias a microphone accessory and is enabled / disabled by the I<sup>2</sup>C register bit LDO ENABLE in the COLTROL register(02h). This LDO requires a 0.22 μF to 1 μF coupling capacitor on the output. The coupling capacitor should be placed close to the LDO pin.

### Headset Key-Press Operation

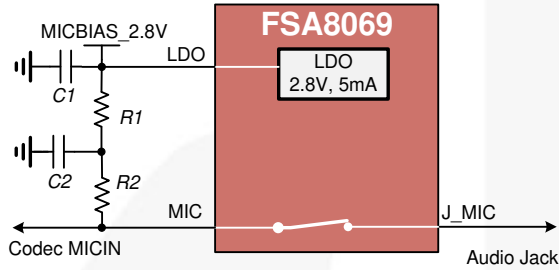
The headset key-press comparator threshold is a function of the MIC bias voltage, MIC bias resistor, and the MIC impedance. All of these variables must be considered when calculating the key-press resistor value. Figure 6 is an example of how to calculate the key-press resistor value.

$$R_{KEY} \leq \frac{1}{\left( \frac{1}{V_{TH\_SE}} - \frac{1}{\frac{V_{BIAS} - V_{TH\_SE}}{R_{BIAS}}} \right) \cdot \frac{1}{R_{MIC}}}$$

$$R_{KEY} \leq 1100 \Omega$$

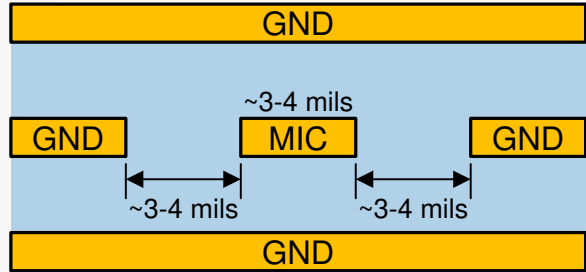
## Recommended LDO Bias Circuit and MIC Switch PCB Layout

PCB layout can degrade the audio quality and be a contributory factor in audible noise coupling issues, high-frequency noise (ESD/ EMI) issues, and signal losses. To avoid unexpected noise issues and to achieve stable regulator output, all external components should be placed as close to the FSA8069 as possible.

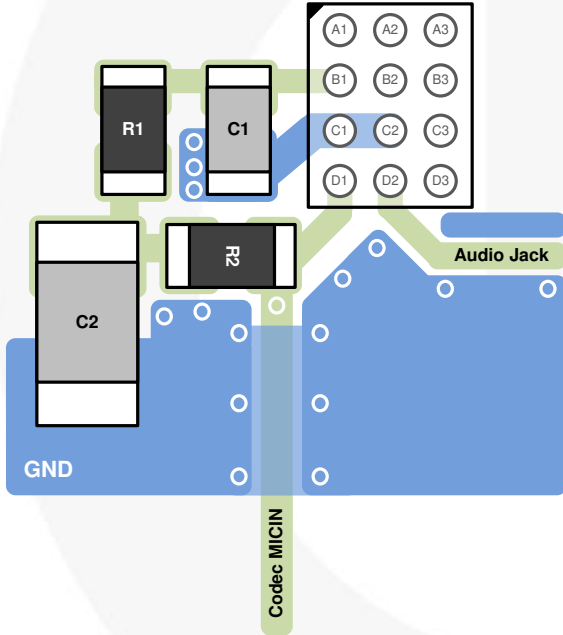


**Figure 7. MIC Bias and MIC Switch Circuit**

Decrease the spacing between the traces for MIC and ground signals between the audio jack to increase the inductive coupling of these signals. In effect, this creates a low-frequency band-pass filter that shunts ESD energy to ground before it reaches internal components. Where feasible, lay the MIC trace as a shielded stripline; as shown in Figure 9.



**Figure 9. MIC PCB Trace as Shield Strip Line**



**Figure 8. Recommended PCB Layout Placement**

## Absolute Maximum Ratings

Stresses exceeding the absolute maximum ratings may damage the device. The device may not function or be operable above the recommended operating conditions and stressing the parts to these levels is not recommended. In addition, extended exposure to stresses above the recommended operating conditions may affect device reliability. The absolute maximum ratings are stress ratings only.

Symbol	Parameter	Min.	Max.	Unit	
$V_{DD}, V_{IO}$	Supply Voltage from Battery	-0.5	6.0	V	
$V_{SW}$	Switch I/O Voltage (MIC, J_MIC)	-0.5	$V_{DD}+0.5$	V	
$V_{JD}$	Input Voltage for J_DET Input	-1.5	$V_{DD}+0.5$	V	
$I_{IK}$	Input Clamp Diode Current	-50		mA	
$I_{SW}$	Switch I/O Current		50	mA	
$T_{STG}$	Storage Temperature Range	-65	+150	°C	
$T_J$	Maximum Junction Temperature		+150	°C	
$T_L$	Lead Temperature (Soldering, 10 Seconds)		+260	°C	
ESD	IEC 61000-4-2 System ESD	Air Gap	15		kV
		Contact	8		
	Human Body Model, ANSI/ESDA/JEDEC JS-001-2012	J_DET, J_MIC, $V_{DD}$ , $V_{IO}$ , GND	8		
		All Other Pins	2		
Charged Device Model, JEDEC JESD22-C101	All Pins	1			

## Recommended Operating Conditions

The Recommended Operating Conditions table defines the conditions for actual device operation. Recommended operating conditions are specified to ensure optimal performance to the datasheet specifications. Fairchild does not recommend exceeding them or designing to Absolute Maximum Ratings.

Symbol	Parameter	Min.	Max.	Unit
$V_{DD}$	Battery Supply Voltage	3.0	4.5	V
$V_{IO}$	Parallel I/O Supply Voltage	1.6	$V_{DD}$	V
$V_{SW}$	Switch Input Voltage (J_MIC, MIC)	0	3.0	V
$T_A$	Operating Temperature	-40	+85	°C
$J\_DET_{AudioV}$	Audio Voltage Range on J_DET Pin	-1.4	+1.4	V
$C_{OUT}$	LDO Output Capacitance	220		nF
$R_{J\_DET}$	Resistance on Audio Accessory Left Channel to Generate Valid Attach		15.75	kΩ

## DC Electrical Characteristics

All typical values are at  $T_A=25^\circ\text{C}$ ,  $C_{IN\_VDD}=1.0\ \mu\text{F}$ ,  $C_{IN\_VIO}=0.1\ \mu\text{F}$ , and  $C_{OUT\_LDO}=0.22\ \mu\text{F}$  unless otherwise specified.

Symbol	Parameter	$V_{DD}$ (V)	Conditions	$T_A = -40$ to $+85^\circ\text{C}$			Unit
				Min.	Typ.	Max.	
<b>MIC Switch</b>							
$R_{ON}$	MIC Switch On Resistance	3.8	$I_{OUT}=30\ \text{mA}$ , $V_{IN}=2.2\ \text{V}$		0.50		$\Omega$
$R_{FLAT(ON)}$	On Resistance Flatness	3.8	$I_{OUT}=30\ \text{mA}$ , $V_{IN}=1.6\ \text{V}$ to $V_{DD}$		0.30	1.50	
$I_{OFF}$	Power-Off Leakage Current Through Switch	0	MIC, J_MIC Ports $V_A=4.3\ \text{V}$			3	$\mu\text{A}$
$I_{ON}$	Input Leakage Current MIC, J_MIC switch ON	3.0 to 4.5	Inputs $V_{MIC}$ , $V_{MIC}=3.0\ \text{V}$ , Other Side of Switch Port Floating			1	$\mu\text{A}$
$I_{OZ}$	Off Leakage Current	4.5	MIC and J_MIC Port $V_{IN}=3.0\ \text{V}$			1	$\mu\text{A}$
<b>Key Press</b>							
$V_{COMP}$	Comparator Threshold for Key Detection	3.0 to 4.5	Detection Threshold (0Fh) [3:0]=1001 (790 mV)		0.79		V
<b>J_DET</b>							
$J\_DET_{Tolerance}$	Tolerance between Impedance Detection Steps (see Table 1)	3.0 to 4.5	Impedance Detection Mode		5%		
<b>Parallel I/O (KP, INTB)</b>							
$V_{OH}$	Output High Voltage		$I_{OH}=-100\ \mu\text{A}$	$0.8 \times V_{IO}$			V
$V_{OL}$	Output Low Voltage		$I_{OL}=+100\ \mu\text{A}$			$0.2 \times V_{IO}$	
<b>I<sup>2</sup>C Controller DC Characteristics Fast Mode (400 kHz)</b>							
$V_{IL}$	Low-Level Input Voltage					$0.3 \times V_{IO}$	V
$V_{IH}$	High-Level Input Voltage			$0.7 \times V_{IO}$			V
$V_{OL1}$	Low-Level Output Voltage at 3 mA Sink Current (Open-Drain)		$V_{IO}>2\ \text{V}$	0		0.4	V
			$V_{IO}<2\ \text{V}$			$0.2 \times V_{IO}$	V
$I_{I2C}$	Input Current of I2C_SDA and I2C_SCL Pins, Input Voltage 0.26 V to 2.34 V			-10		+10	$\mu\text{A}$
<b>Current</b>							
$I_{DD\_SLNA}$	Battery Supply Sleep Mode Current with No Accessory Attached and LDO Disabled	3.0 to 4.5	Static Current during Sleep Mode		1.5		$\mu\text{A}$
$I_{DD\_SLWA}$	Battery Supply Sleep Mode Current with Accessory Attached	3.0 to 4.5	Active Current		30		$\mu\text{A}$
$I_{DD\_LDO}$	LDO Quiescent Current	3.0 to 4.5	$I_{LOAD}=0\ \text{mA}$ , $C_{OUT}=0\ \text{pF}$ , LDO Enabled		100		$\mu\text{A}$
<b>LDO</b>							
$V_{OUT}$	Output Voltage (Output=2.8 V)	3.0 to 4.5	$I_{LOAD}=1\ \text{mA}$	2.77	2.80	2.83	V
$I_{OUT}$	Maximum Output Current	3.0 to 4.5		5			mA



## AC Electrical Characteristics

All typical values are for  $V_{CC}=3.3\text{ V}$  at  $T_A=25^\circ\text{C}$ ,  $C_{IN\_VDD}=1.0\ \mu\text{F}$ ,  $C_{IN\_VIO}=0.1\ \mu\text{F}$ , and  $C_{OUT\_LDO}=0.22\ \mu\text{F}$  unless otherwise specified. Not production tested.

Symbol	Parameter	$V_{DD}$ (V)	Conditions	Typical	Unit
<b>MIC Switch</b>					
THD	Total Harmonic Distortion	3.0	$R_T=600\ \Omega$ , $f=20\ \text{Hz to } 20\ \text{kHz}$ , $V_{IN}=2.0\ \text{V} + 0.5\ V_{pp}$ Sine	0.01	%
OIRR	Off Isolation	3.0	$f=20\ \text{kHz}$ , $R_S=600\ \Omega$ , $C_L=0\ \text{pF}$ , $R_T=600\ \Omega$	-85	dB
PSRR <sub>sw</sub>	Power Supply Rejection Ratio (at 217 Hz)	4.0	Power Supply Noise 300 mV <sub>PP</sub> , 87.5% Duty Cycle,	-80	dB
<b>Timing Characteristics</b>					
$t_{POLL}$	ON Time of MIC Switch for Sensing SEND / END Key Press Oscillator Stable Time	3.0 to 4.5	I <sup>2</sup> C Register Adjustable ( $t_{POLL}[3:0]$ )	15 (Default)	ms
$t_{WAIT}$	Period of MIC Switching for Sensing SEND / END Key Press	3.0 to 4.5	I <sup>2</sup> C Register Adjustable ( $t_{WAIT}[3:0]$ )	150 (Default)	ms
$t_{DET\_IN}$	Debounce Time after J_DET Changes State from HIGH to LOW	3.0 to 4.5	I <sup>2</sup> C Register Adjustable ( $t_{DET\_IN}[3:0]$ )	25 (Default)	ms
$t_{MIC\_SW\_OPEN}$	Time of MIC Switch Open after J_DET Changes State from LOW to HIGH	3.0 to 4.5		30	$\mu\text{s}$
$t_{KBK}$	Debounce Time for Sensing SEND / END Key Press / Release	3.0 to 4.5	I <sup>2</sup> C Register Adjustable ( $t_{KBK}[3:0]$ )	30 (Default)	ms
$t_{DET\_REM}$	Debounce Time from Changing J_DET State from LOW to HIGH to Detect Jack Removal	3.0 to 4.5	I <sup>2</sup> C Register Adjustable ( $t_{DET\_REM}[3:0]$ )	1 (Default)	ms
$t_{EXTRA}$	Additional Time to Keep Switch Closed in Music Mode after Key Release	3.0 to 4.5		600	ms
$t_{REG\_DFT}$	Time to Set Registers to Defaults from Falling and Rising $V_{IO}$	3.0 to 4.5		1	ms
<b>LDO</b>					
PSRR <sub>LDO</sub>	Power Supply Rejection Ratio (at 217 Hz)	4.5	Power Supply Noise 300 mV <sub>PP</sub> , 87.5% Duty Cycle, $C_{OUT}=1\ \mu\text{F}$	-80	dB

## I<sup>2</sup>C Specifications

Symbol	Parameter	Fast Mode		
		Min.	Max.	Unit
f <sub>SCL</sub>	I2C_SCL Clock Frequency	0	400	kHz
t <sub>HD;STA</sub>	Hold Time (Repeated) START Condition	0.6		μs
t <sub>LOW</sub>	Low Period of I2C_SCL Clock	1.3		μs
t <sub>HIGH</sub>	High Period of I2C_SCL Clock	0.6		μs
t <sub>SU;STA</sub>	Set-up Time for Repeated START Condition	0.6		μs
t <sub>HD;DAT</sub>	Data Hold Time	0	0.9	μs
t <sub>SU;DAT</sub>	Data Set-up Time <sup>(6)</sup>	100		ns
t <sub>r</sub>	Rise Time of I2C_SDA and I2C_SCL Signals <sup>(6)</sup>	20+0.1C <sub>b</sub>	300	ns
t <sub>f</sub>	Fall Time of I2C_SDA and I2C_SCL Signals <sup>(6)</sup>	20+0.1C <sub>b</sub>	300	ns
t <sub>SU;STO</sub>	Set-up Time for STOP Condition	0.6		μs
t <sub>BUF</sub>	Bus-Free Time between STOP and START Conditions	1.3		μs
t <sub>SP</sub>	Pulse Width of Spikes that Must Be Suppressed by the Input Filter	0	50	ns

### Notes:

- A Fast-Mode I<sup>2</sup>C-Bus® device can be used in a Standard-Mode I<sup>2</sup>C-Bus system, but the requirement t<sub>SU;DAT</sub> ≥ 250 ns must be met. This is automatically the case if the device does not stretch the LOW period of the I2C\_SCL signal. If a device does stretch the LOW period of the I2C\_SCL signal, it must output the next data bit to the I2C\_SDA line t<sub>r,max</sub> + t<sub>SU;DAT</sub> = 1000 + 250 = 1250 ns (according to the Standard Mode I<sup>2</sup>C-Bus specification) before the I2C\_SCL line is released.
- C<sub>b</sub> equals the total capacitance of one bus line in pF. If mixed with high-speed devices, faster fall times are allowed according to the I<sup>2</sup>C specification.

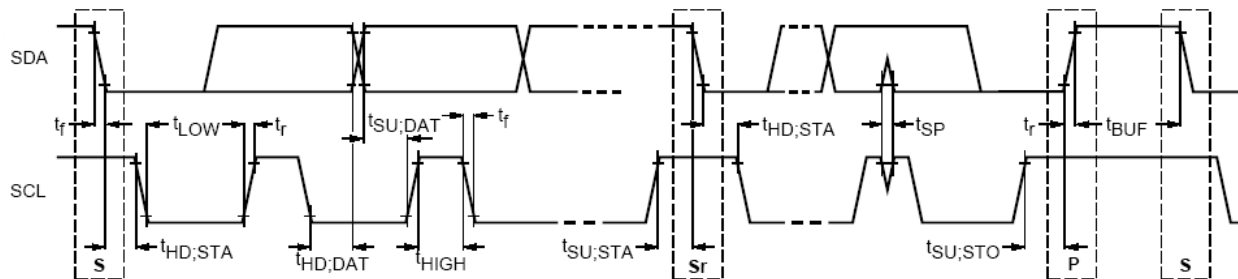


Figure 10. Definition of Timing for Full-Speed Mode Devices on the I<sup>2</sup>C Bus

Table 2. I<sup>2</sup>C Slave Address

Name	Size (Bits)	Bit 7	Bit 6	Bit 5	Bit 4	Bit 3	Bit 2	Bit 1	Bit 0
Slave Address	8	0	1	0	0	0	1	1	Read/Write

## Register Map

Addr.	Register	Type	Reset Values	Bit 7	Bit 6	Bit 5	Bit 4	Bit 3	Bit 2	Bit 1	Bit 0
01H	Device ID	R	0000XXXX	Version ID				Reserved*			
02H	Control	R/W	XXXX0010	Reserved	Reserved	Reserved	Reserved	LDO Enable	Key Detection Enable	Reserved for Future Applications	Music Mode Enable
03H	Status	R	XXXX0000	Reserved	Reserved	Reserved	Reserved	Impedance Attached Status	Impedance status [2:0] 000: Impedance Type 0 (16 Ω) 001: Impedance Type 1 (32 Ω) 010: Impedance Type 2 (64 Ω) 011: Impedance Type 3 (150 Ω) 100: Impedance Type 4 (300 Ω) 101: Impedance Type 5 (600 Ω) 110: Impedance Type 6 (2 kΩ) 111: Moisture Detection		
04H	Interrupt 1	R/C	XXXXX000	Reserved	Reserved	Reserved	Reserved	Reserved	Moisture Change	Plug removal	Plug insertion
05H	Interrupt 2	R/C	XX000000	Reserved	Reserved	Reserved	Reserved	Key Release	Reserved	Reserved	Key Press
07H	Interrupt Mask 1	R/W	XXXXX000	Reserved	Reserved	Reserved*	Reserved*	Reserved*	Moisture Change Mask	Plug Removal Mask	Plug Insertion Mask
08H	Interrupt Mask 2	R/W	XX000000	Reserved	Reserved	Reserved	Reserved	Key Release Mask	Reserved	Reserved	Key Press Mask
0AH	J_DET Timing	R/W	00001001	Insert ( $t_{DET-IN}$ )				Removal ( $t_{DET-REM}$ )			
0BH	Music Mode Timing	R/W	00101000	Key-Press Polling Time ( $t_{POLL}$ )				Key-Press Waiting Time ( $t_{WAIT}$ )			
0CH	Key Debounce Timing	R/W	XXXX0101	Reserved	Reserved	Reserved	Reserved	Key-Press Debounce Timing ( $t_{KBK}$ )			
0EH	Reserved	R/W	XXXX1000	Reserved	Reserved	Reserved	Reserved	Reserved	Reserved	Reserved	Reserved
0FH	Detection Thresholds	R/W	10011000	Key Threshold [3:0]				Reserved	Reserved	Reserved	Reserved
10H	Reset	R/W	XXXXXXXX0	Reserved	Reserved	Reserved	Reserved	Reserved	Reserved	Reserved	Reset

## Notes:

8. Do not use registers that are blank and reserved.
9. Write "0" to undefined register bits.
10. Values read from undefined register bits are not defined and are invalid.



## Register Definition

**Table 3. Address: 01H Type: Read**

DEVICE ID			Default	xxxx0000
Bit #	Name	Size	Function	
3:0	Reserved	4	Do Not Use	
7:4	Version ID	4	0000 = Version 0.0 0001 = Version 0.1	

**Table 4. Address: 02H Type: Read/Write**

CONTROL			Default	xxxx0010
Bit #	Name	Size	Function	
0	Music Mode Enable	1	0: Music Mode disabled (MIC switch keep closed or opened) 1: Music Mode enabled (MIC switch repeats open and close if plug inserted completely)	
1	Reserved	1	Do Not Use Reserved for future applications, default = 1	
2	Key Detection Enable	1	0: Key detection disabled (Default) 1: Key detection enabled	
3	LDO Enable	1	0: LDO disabled (Default) 1: LDO enabled	
7:4	Reserved	4	Do Not Use	

**Table 5. Address: 03H Type: Read**

STATUS			Default	xxxx0000
Bit #	Name	Size	Function	
2:0	Impedance Status	3	Only valid at Impedance Accessory Attached bit set 000: <b>Impedance Type 0 (16 Ω) (Default)</b> 001: Impedance Type 1 (32 Ω) 010: Impedance Type 2 (64 Ω) 011: Impedance Type 3 (150 Ω) 100: Impedance Type 4 (300 Ω) 101: Impedance Type 5 (600 Ω) 110: Impedance Type 6 (2k Ω) 111: Moisture detected	
3	Impedance Accessory Attached	1	0: Accessory not attached (Default) 1: Accessory attached and Impedance Status[2:0] valid	
7:4	Reserved	4	Do Not Use	

**Table 6. Address: 04H Type: Read/Clear**

INTERRUPT 1			Default	xx000000
Bit #	Name	Size	Function	
0	Plug Insertion	1	<b>0: Plug Insertion not detected (Default)</b> 1: Plug Insertion detected	
1	Plug Removal	1	<b>0: Plug removal not detected (Default)</b> 1: Plug removal detected	
2	Moisture Change	1	<b>0: Moisture status not changed (Default)</b> 1: Moisture status changed	
7:4	Reserved	4	Do Not Use	

**Table 7. Address: 05H Type: Read/Clear**

INTERRUPT 2			Default	xxxx0xx0
Bit #	Name	Size	Function	
0	Key Press	1	<b>0: Key not pressed (Default)</b> 1: Key pressed	
2:1	Reserved	2	Do Not Use	
3	Key Release	1	<b>0: Key not released (Default)</b> 1: Key released	
7:4	Reserved	4	Do Not Use	

**Table 8. Address: 07H Type: Read/Write**

ITERRUPT MASK1			Default	xxxxx000
Bit #	Name	Size	Function	
0	Plug Insertion Mask	1	<b>0: Plug insert detection not masked (Default)</b> 1: Plug insert detection masked	
1	Plug Removal Mask	1	<b>0: Plug removal detection not masked (Default)</b> 1: Plug removal detect masked	
2	Moisture Change Mask	1	<b>0: Moisture change not masked (Default)</b> 1: Moisture change masked	
7:3	Reserved	5	Do Not Use	

**Table 9. Address: 08H Type: Read/Write**

INTERRUPT MASK 2			Default	xxxx0xx0
Bit #	Name	Size	Function	
0	Key Press Mask	1	<b>0: Key press not masked (Default)</b> 1: Key press masked	
2:1	Reserved	2	Do Not Use	
3	Key Release Mask	1	<b>0: Key release not masked (Default)</b> 1: Key release masked	
7:4	Reserved	4	Do Not Use	

**Table 10. Address: 0AH**

**Type: Read/Write**

J_DET TIMING			Default	00001001
Bit #	Name	Size	Function	
3:0	<p><b>t<sub>DET_REM</sub>[3:0]</b> Plug Removal Debounce Timing</p>	4	0000: 100 μs 0001: 200 μs 0010: 300 μs 0011: 400 μs 0100: 500 μs 0101: 600 μs 0110: 700 μs 0111: 800 μs 1000: 900 μs <b>1001: 1000 μs</b> 1010: 1200 μs 1011: 1400 μs 1100: 1600 μs 1101: 1800 μs 1110: 2000 μs 1111: 5000 μs	
7:4	<p><b>t<sub>DET_IN</sub>[3:0]</b> Plug Insertion Debounce Time</p>	4	<b>0000: 25 ms</b> 0001: 50 ms 0010: 75 ms 0011: 100 ms 0100: 125 ms 0101: 150 ms 0110: 175 ms 0111: 200 ms 1000: 225ms 1001: 250 ms 1010: 275 ms 1011: 300 ms 1100: 325 ms 1101: 350 ms 1110: 375 ms 1111: 400 ms	

**Table 11. Address: 0BH**

**Type: Read/Write**

MUSIC MODE TIMING			Default	00101000
Bit #	Name	Size	Function	
3:0	<p><b>t<sub>WAIT</sub>[3:0]</b> Key Press Waiting Time in Music Mode</p>	4	0000: 5 ms 0001: 10 ms 0010: 15 ms 0011: 20 ms 0100: 25 ms 0101: 30 ms 0110: 50 ms 0111: 100 ms <b>1000: 150 ms (Default)</b> 1001: 200 ms 1010: 250 ms	



**Table 13. Address: 0FH Type: Read/Write**

DETECTION THRESHOLD			Default	1001xxxx
Bit #	Name	Size	Function	
3:0	Reserved	4	Do Not Use	
7:4	<p><b>Key [3:0]</b></p> <p>Key Threshold</p>	4	0000: 660 mV 0001: 680 mV 0010: 700 mV 0011: 710 mV 0100: 730 mV 0101: 750 mV 0110: 760 mV 0111: 770 mV 1000: 780 mV <b>1001: 790 mV (Default)</b> 1010: 800 mV 1011: 810 mV 1100: 830 mV 1101: 850 mV 1110: 870 mV 1111: 890 mV	

**Table 14. Address: 10H Type: Read/Write**

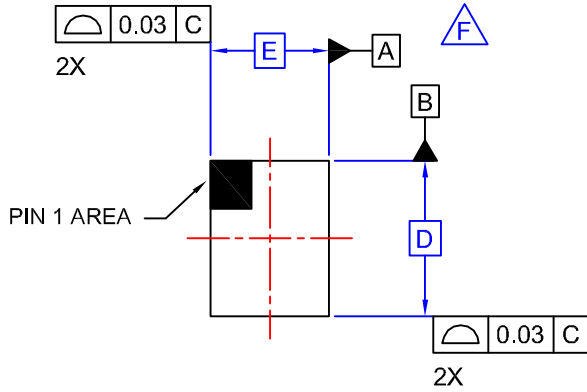
RESET			Default	xxxxxxx0
Bit #	Name	Size	Function	
0	<p><b>Reset</b></p> <p>After reset, this bit is automatically cleared to '0'</p>	4	0: No Change 1: Reset Device – Reset all I <sup>2</sup> C register to default values.	
7:1	Reserved	7	Do Not Use	

**Package Specific Dimensions**

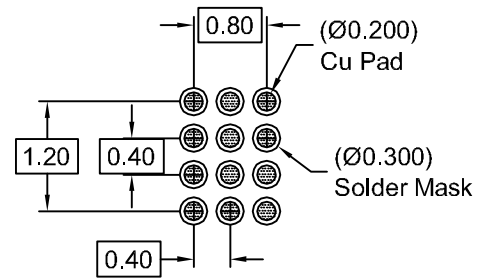
D	E	X	Y
1.615 mm	1.415 mm	0.3075 mm	0.2075 mm



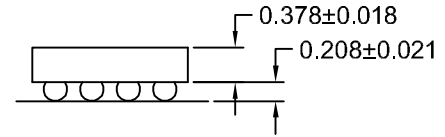
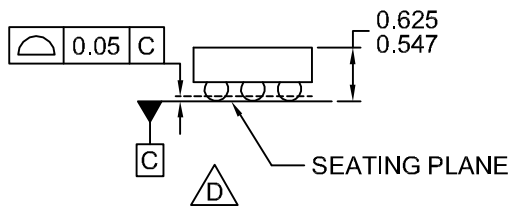
REVISIONS			
REV	DESCRIPTION	DATE	APP'D / SITE
1	Initial drawing release.	8-19-09	L. England / FSME



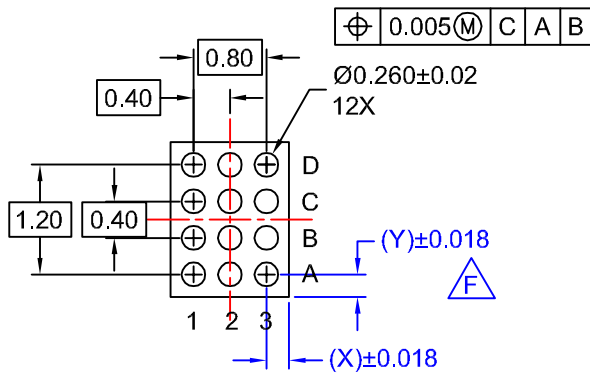
TOP VIEW



RECOMMENDED LAND PATTERN  
(NSMD PAD TYPE)



SIDE VIEWS



BOTTOM VIEW

NOTES:

- A. NO JEDEC REGISTRATION APPLIES.
- B. DIMENSIONS ARE IN MILLIMETERS.
- C. DIMENSIONS AND TOLERANCES PER ASME Y14.5M, 1994.
- D. DATUM C IS DEFINED BY THE SPHERICAL CROWNS OF THE BALLS.
- E. PACKAGE NOMINAL HEIGHT IS 586 MICRONS ±39 MICRONS (547-625 MICRONS).
- F. FOR DIMENSIONS D, E, X, AND Y SEE PRODUCT DATASHEET.
- G. DRAWING FILENAME: MKT-UC012ACrev1.

APPROVALS		DATE	FAIRCHILD SEMICONDUCTOR™			
DRAWN	L. England	8-19-09	12BALL WLCSP, 3X4 ARRAY 0.4MM PITCH, 250UM BALL			
DFTG. CHK.	S. Martin	8-19-09				
ENGR. CHK.						
			SCALE	SIZE	DRAWING NUMBER	REV
			N/A	N/A	MKT-UC012AC	1
			DO NOT SCALE DRAWING		SHEET 1 of 1	

ON Semiconductor and  are trademarks of Semiconductor Components Industries, LLC dba ON Semiconductor or its subsidiaries in the United States and/or other countries. ON Semiconductor owns the rights to a number of patents, trademarks, copyrights, trade secrets, and other intellectual property. A listing of ON Semiconductor's product/patent coverage may be accessed at [www.onsemi.com/site/pdf/Patent-Marking.pdf](http://www.onsemi.com/site/pdf/Patent-Marking.pdf). ON Semiconductor reserves the right to make changes without further notice to any products herein. ON Semiconductor makes no warranty, representation or guarantee regarding the suitability of its products for any particular purpose, nor does ON Semiconductor assume any liability arising out of the application or use of any product or circuit, and specifically disclaims any and all liability, including without limitation special, consequential or incidental damages. Buyer is responsible for its products and applications using ON Semiconductor products, including compliance with all laws, regulations and safety requirements or standards, regardless of any support or applications information provided by ON Semiconductor. "Typical" parameters which may be provided in ON Semiconductor data sheets and/or specifications can and do vary in different applications and actual performance may vary over time. All operating parameters, including "Typicals" must be validated for each customer application by customer's technical experts. ON Semiconductor does not convey any license under its patent rights nor the rights of others. ON Semiconductor products are not designed, intended, or authorized for use as a critical component in life support systems or any FDA Class 3 medical devices or medical devices with a same or similar classification in a foreign jurisdiction or any devices intended for implantation in the human body. Should Buyer purchase or use ON Semiconductor products for any such unintended or unauthorized application, Buyer shall indemnify and hold ON Semiconductor and its officers, employees, subsidiaries, affiliates, and distributors harmless against all claims, costs, damages, and expenses, and reasonable attorney fees arising out of, directly or indirectly, any claim of personal injury or death associated with such unintended or unauthorized use, even if such claim alleges that ON Semiconductor was negligent regarding the design or manufacture of the part. ON Semiconductor is an Equal Opportunity/Affirmative Action Employer. This literature is subject to all applicable copyright laws and is not for resale in any manner.

## PUBLICATION ORDERING INFORMATION

### LITERATURE FULFILLMENT:

Literature Distribution Center for ON Semiconductor  
19521 E. 32nd Pkwy, Aurora, Colorado 80011 USA  
**Phone:** 303-675-2175 or 800-344-3860 Toll Free USA/Canada  
**Fax:** 303-675-2176 or 800-344-3867 Toll Free USA/Canada  
**Email:** [orderlit@onsemi.com](mailto:orderlit@onsemi.com)

**N. American Technical Support:** 800-282-9855 Toll Free  
USA/Canada  
**Europe, Middle East and Africa Technical Support:**  
Phone: 421 33 790 2910  
**Japan Customer Focus Center**  
Phone: 81-3-5817-1050

**ON Semiconductor Website:** [www.onsemi.com](http://www.onsemi.com)  
**Order Literature:** <http://www.onsemi.com/orderlit>  
For additional information, please contact your local  
Sales Representative