

THIS DRAWING IS SUPPLIED FOR INFORMATION ONLY. DESIGN FEATURES, SPECIFICATIONS AND PERFORMANCE DATA SHOWN HEREON ARE THE PROPERTY OF THE AMPHENOL CORPORATION. NO RIGHTS OF REPRODUCTION ARE IMPLIED. ALL DIMENSIONS ARE SUBJECT TO NORMAL MANUFACTURING VARIATIONS.

Customer Drawing

REVISIONS					
REV	ZONE	ECO	DESCRIPTION	DATE	BY APPR
A	--	--	INITIAL RELEASE	03/13/14	RW EC
G	--	--	Add Dust Cap & Change HVIL Wire, Update Spec.	03/29/16	RW TS
H	--	--	Add Geometric Tolerance of Flange & Panel	10/21/16	RW PL
I	--	--	Change Shell and Gasket	05/10/17	Sam Julie

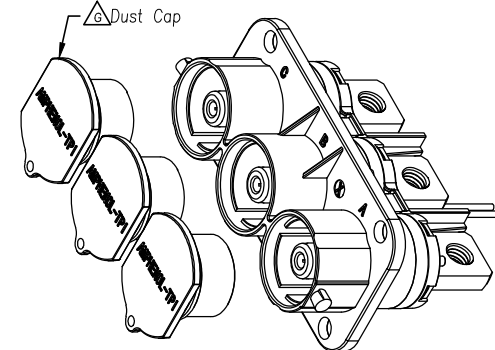
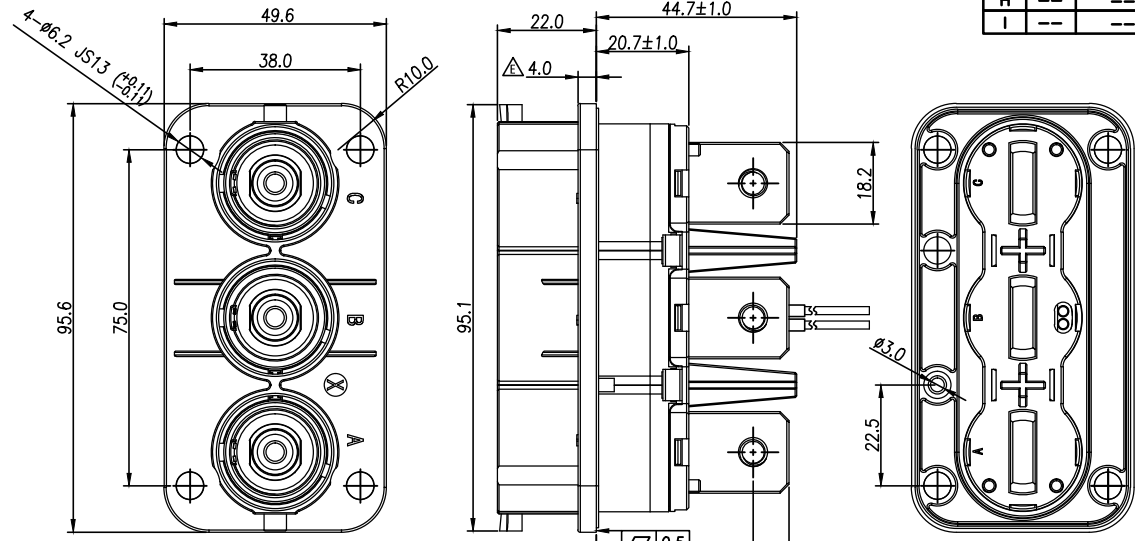

- Notices:
- All non-dimensioned surfaces according to 3D-model & $\nabla 3$
 - Planeness of panel surface should less than or equal to 0.1mm
 - Roughness of panel surface should be $\sqrt{3}$ or better.
 - Thickness of panel should not exceed 12mm.

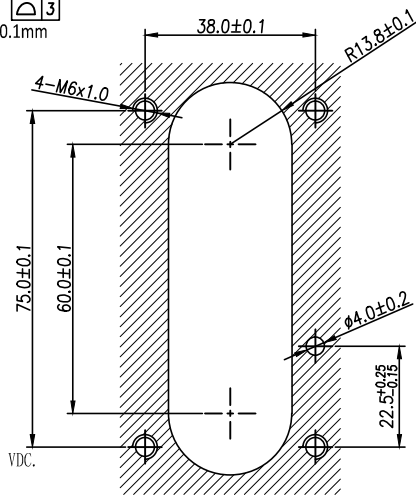

- 规格参数 (Spec.):
- 工作温度 Operating temperature: $-40^{\circ}\text{C} \sim +125^{\circ}\text{C}$.
 - 带高压互锁 Electrical interlock (HVIL).
 - 额定电流 Current rating:
Power: 300A; HVIL: 5A.
 - 额定电压 Operating voltage:
Power: 1000 VDC; Signal: 60 VDC.
 - 耐电压 Dielectric withstanding voltage:
 - 与插头对插后, Pin与铁壳之间
After mating, between pin and metal shell :5000 VDC.
 - 与插头对插后, Pin与HVIL之间
After mating, between pin and HVIL :5000 VDC.
 - 与插头对插后, HVIL与铁壳之间
After mating, between HVIL and metal shell :500 VDC.
 - 与插头对插前, 两个HVIL端子之间耐压
Before mating, between two HVIL terminals :500 VDC.

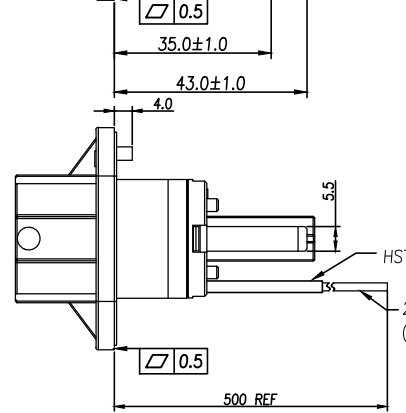

Standard Part List (With HVIL)

P/N	Model NO.	Mating Plug Model NO.
AC-HA001132	PL083X-301-10D10	PL183X-301-XX, PL283X-301-XX
AC-HA001133	PL083Y-301-10D10	PL183Y-301-XX, PL283Y-301-XX
AC-HA001136	PL083X-301-10D8	PL183X-301-XX, PL283X-301-XX
AC-HA001137	PL083Y-301-10D8	PL183Y-301-XX, PL283Y-301-XX
AC-HA001138	PL083X-301-10M8	PL183X-301-XX, PL283X-301-XX
AC-HA001139	PL083Y-301-10M8	PL183Y-301-XX, PL283Y-301-XX
AC-HA001142	PL083X-301-10M6	PL183X-301-XX, PL283X-301-XX
AC-HA001143	PL083Y-301-10M6	PL183Y-301-XX, PL283Y-301-XX

Standard Part List (With Out HVIL)

P/N	Model NO.	Mating Plug Model NO.
AC-HA001144	PL083X-300-10D10	PL183X-300-XX, PL283X-300-XX
AC-HA001145	PL083Y-300-10D10	PL183Y-300-XX, PL283Y-300-XX
AC-HA001148	PL083X-300-10D8	PL183X-300-XX, PL283X-300-XX
AC-HA001149	PL083Y-300-10D8	PL183Y-300-XX, PL283Y-300-XX
AC-HA001150	PL083X-300-10M8	PL183X-300-XX, PL283X-300-XX
AC-HA001151	PL083Y-300-10M8	PL183Y-300-XX, PL283Y-300-XX
AC-HA001154	PL083X-300-10M6	PL183X-300-XX, PL283X-300-XX
AC-HA001155	PL083Y-300-10M6	PL183Y-300-XX, PL283Y-300-XX

订购信息 Ordering Information

PL083	X	-	30	1	-	10	D	8
键位及颜色 Key	高压互锁 HVIL	孔种类 Hole Type	联接螺栓 Bolt Size					
"X" Key	0, 不带互锁 No HVIL	D, 通孔 Through Hole	M, 联接孔 Screw Hole	Customer Define				
"Y" Key	1, 带互锁 With HVIL	H, 腰孔 Slotted Hole						

- 防护等级 Protection class: IP67 & IP2X.
- 电磁屏蔽 Shielding.
- 机械寿命 Mating cycle: 50 Min.
- 带自动二次锁扣 Automatic secondary lock.
- 铜排推荐安装扭矩 Recommended Fasten Torque on Lug:
M6 : 3.6~4.4 Nm
M8 : 7.2~8.8 Nm
M10: 17.1~20.9 Nm
- 推荐法兰盘螺丝安装扭矩 Recommended Screw Assembly Torque on Flange : 6.2~7.6 Nm

Amphenol Technical Products International GZ

第三角投影 THIRD ANGLE PROJECTION	页面 SHEET	幅面 SIZE	版次 REV.	比例 SCALE	PART NAME: PwrLok 10mm 3POS Rcpt Conn
	1 of 1	A3	1		DWG NO: PL083-300-10
签名 SIGNATURE: Sam 日期 DATE: 05/10/17 制图 DRAWN: Sam 审核 CHECKED: Julie 批准 APPROVAL: Hkey					UNLESS OTHERWISE SPECIFIED 1) All dimensions are in metric (mm). 2) Tolerances are as follows: 0 PL DEC ±1.00 1 PL DEC ±0.50 2 PL DEC ±0.20 Angles ±1°
					CUST PART #: N/A
					CUST REV. -