

NOTES:

ELECTRICAL:

1. VOLTAGE RATING : 125 VAC RMS.
2. CURRENT RATING : 1.5 AMP.
3. CONTACT RESISTANCE : 35 MILLIOHMS MAX.
4. INSULATION RESISTANCE: 1000 MEGOHMS MIN @ 500 VDC.
5. DIELECTRIC STRENGTH : 1000 VAC RMS 60Hz, 1MIN.

MECHANICAL:

1. HOUSING MATERIAL : GLASS FILLED PBT UL94V-0.
2. CONTACT MATERIAL : PHOSPHOR BRONZE t=0.35mm.
3. PLATING : GOLD PLATING OVER NICKEL.
4. OPERATING LIFE : 750 CYCLES MIN.
5. PCB RETENTION PRE-SOLDER : 1 LB MIN.
6. PCB RETENTION POST-SOLDER: 10 LBS MIN.

ENVIRONMENTAL:

1. STORAGE TEMPERATURE : -40°C TO +85°C.
2. OPERATION TEMPERATURE: -40°C TO +85°C.
3. WAVE SOLDERING TEMPERATURE: 230°C TO 250°C(3-5 SECONDS).
4. RoHS COMPLIANT.

MATES WITH MODULAR PLUG CONFORMING TO FCC PART 68, SUBPART F.

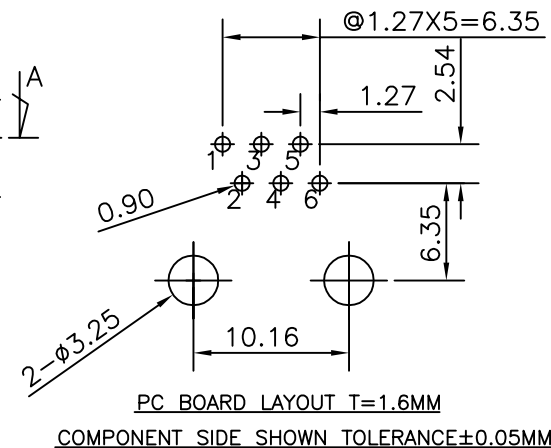
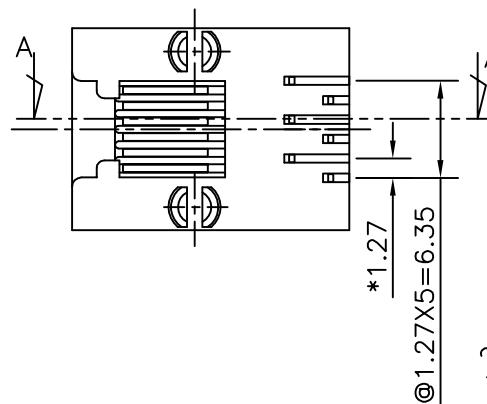

PART NUMBER	CONTACT	GOLD PLATING
E5362-F00212-L	2	6u"
E5362-F00215-L	2	50u"
E5364-F00212-L	4	6u"
E5364-F00214-L	4	30u"
E5366-F00212-L	6	6u"

DETACHED LISTS	← MM (INCH) →	RoHS Compliant			
	TOLERANCES EXCEPT AS NOTED				
	MM	TITLE			
	.0 ± 0.2 ±	DEEP TYPE 11.5 SIDE ENTRY 6P			
.00 ± 0.15 ±	DFTO Cathy		DRAWING NO. CE533079-LC		SIZE
.000 ± 0.075 ±	DATE 2006/09/19		/PART NO. SEE TABLE		REV
ANGLES ± 0.5	SCALE : 3:1		DO NOT SCALE DRAWING		SHEET 1 OF 1