

# OV5695 5-megapixel product brief



## High Quality 1/4-inch 5-Megapixel Selfies for Next-Generation Smartphones and Tablets



available in  
a lead-free  
package

OmniVision's new 1/4-inch OV5695 is a high performance and cost-effective 5-megapixel OmniBSI+™ sensor designed to be a cost-competitive camera solution for both front- and rear-facing camera applications in smartphones and tablets. The OV5695 features an improved design that offers superior image and video quality in a more compact, power-efficient package.

The OV5695 utilizes 1.4-micron OmniBSI+ pixel architecture to capture full resolution video in a native 4:3 aspect ratio at 30 fps or 1080p video at 60 fps with support for interleave row high dynamic range (iHDR).

The sensor's exceptional low-light sensitivity enhances image and video quality when recording in low-light conditions, and reduces user dependence on the device's front-facing flash functionality.

The OV5695 fits into an 8.5 x 8.5 mm module with a z-height of approximately 4.4 mm.

Find out more at [www.ovt.com](http://www.ovt.com).



## Applications

- Smartphones and Feature Phones
- Tablets
- PC Multimedia
- Wearables

## Product Features

- 1.4  $\mu\text{m}$  x 1.4  $\mu\text{m}$  pixel
- 5MP at 30 fps
- programmable controls for:
  - frame rate
  - mirror and flip
  - cropping
  - windowing
- supports images sizes:
  - 5MP (2592x1944)
  - quad HD (2560x1440)
  - 1080p (1920x1080)
  - 720p (1280x720)
  - VGA (640 x 480), and more
- 16 bytes of embedded one-time programmable (OTP) memory for customer use
- ultra low power mode (ULPM)
- support for output formats: 10-bit RGB RAW
- interleave row HDR output
- two-wire serial bus control (SCCB)
- MIPI serial output interface (1- or 2-lane)
- 2x binning support
- image quality control:
  - defect pixel correction
  - automatic black level calibration

# OV5695



## Ordering Information

- OV5695-GA4A-1B**  
(color, chip probing, 200  $\mu\text{m}$  backgrinding, rev 1B, reconstructed wafer)

## Product Specifications

- active array size:** 2592 x 1944
- power supply:**
  - core: 1.14 - 1.26V (1.2V nominal)
  - analog: 2.7 - 3.0V (2.8V nominal)
  - I/O: 1.7 - 1.9V (1.8V nominal)
- power requirements:**
  - active: 155 mW
  - standby: 61  $\mu\text{W}$
  - XSHUTDOWN: 36  $\mu\text{W}$
- temperature range:**
  - operating: -30°C to +70°C junction temperature
  - stable image: -20°C to +60°C junction temperature
- output interface:** 2-lane MIPI serial output
- output formats:** 10-bit RGB RAW
- lens size:** 1/4"
- lens chief ray angle:** 31.08° non-linear
- input clock frequency:** 6 - 27 MHz
- maximum image transfer rate:**
  - 5MP (2592x1944): 30 fps
  - quad HD (2560x1440): 30 fps
  - 1080p (1920x1080): 60 fps
  - 720p (1280x720): 60 fps
  - VGA (640x480): 120 fps
- pixel size:** 1.4  $\mu\text{m}$  x 1.4  $\mu\text{m}$
- dark current:** 15 e<sup>-</sup>/sec @ 60°C junction temperature
- image area:** 3684  $\mu\text{m}$  x 2763  $\mu\text{m}$
- dimensions:**
  - COB: 5022  $\mu\text{m}$  x 3933  $\mu\text{m}$
  - RW: 5072  $\mu\text{m}$  x 3983  $\mu\text{m}$

## Functional Block Diagram

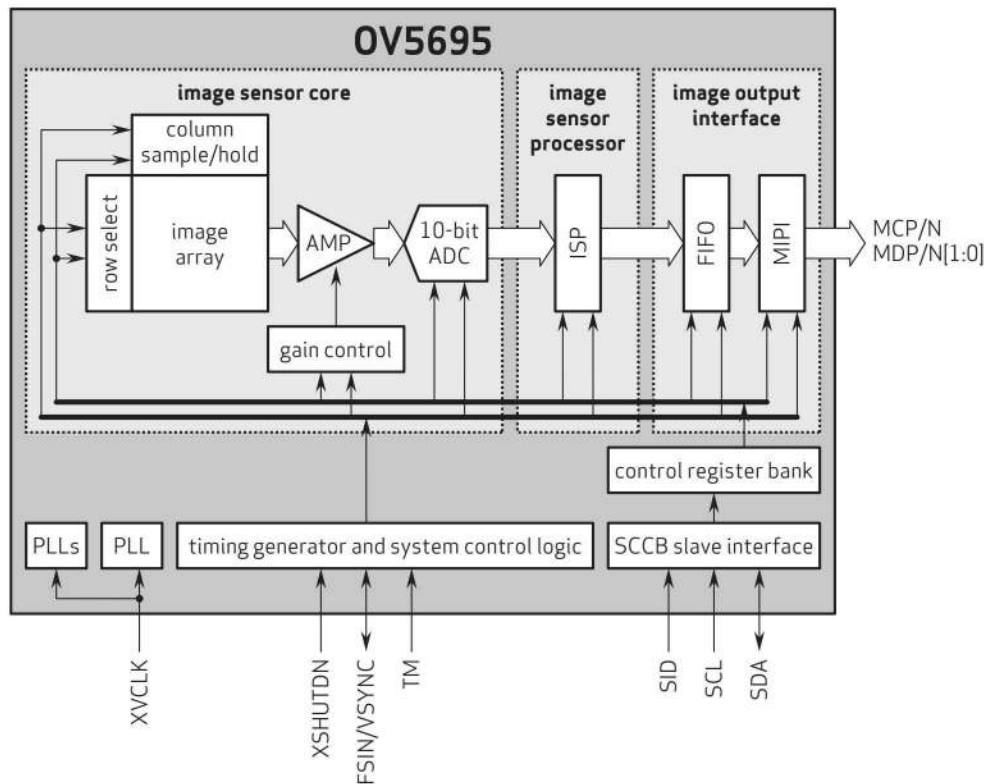

4275 Burton Drive  
Santa Clara, CA 95054  
USA

Tel: +1 408 567 3000  
Fax: +1 408 567 3001  
www.ovt.com

OmniVision reserves the right to make changes to their products or to discontinue any product or service without further notice. OmniVision, the OmniVision logo and OmniPixel are registered trademarks of OmniVision Technologies, Inc. OmniBSI+ is a trademark of OmniVision Technologies, Inc. All other trademarks are the property of their respective owners.



OmniVision