

Isolated DC/DC Converter IC

Isolated Type Fly-back Converter IC with Integrated Switching MOSFET for Automotive

BD7F105EFJ-C

General Description

BD7F105EFJ-C is an opto-coupler-less isolated flyback converter. Feedback circuit by optocouplers or the auxiliary winding of transformers becomes unnecessary, contributing to reduction of set parts. Furthermore, the adoption of original adapted ON-time control technology enables fast load response. In addition, the various protection function realizes the designs of isolated power supply application for high reliability.

Features

- AEC-Q100 Qualified (Note 1)
- No Need for Optocoupler and Third Winding of Transformer
- Set Output Voltage with Two External Resistors and Ratio of Transformer Turns
- Adopt of Original Adapted ON-time Control Technology Fast Load Response
- High Efficiency at Light Load Mode (PFM Operation)
- Shutdown Function / Enable Control
- Built-in 60 V Switching MOSFET
- Frequency Spectrum Spread
- Soft Start Function
- Load Compensation Function
- Various Protection Function
 - Input Low Voltage Lockout (UVLO)
 - Over Current Protection (OCP)
 - Thermal Shutdown (TSD)
 - REF Pin Open Protection (REFOPEN)
 - Short Circuit Protection (SCP)
 - Battery Short Protection (BSP)
- HTSOP-J8 Package
(Note 1) Grade 1

Key Specifications

- Input Voltage Range:
 - VIN Pin 3.4 V to 42.0 V
 - SW Pin 60 V (Max)
- Switching Frequency: 363 kHz (Typ)
- Reference Voltage Precision: $\pm 2.8\%$ (Typ)
- Shutdown Current: 0 μ A (Typ)
- Operating Ambient Temperature Range -40 °C to +125 °C

Package

HTSOP-J8

W (Typ) x D (Typ) x H (Max)

4.9 mm x 6.0 mm x 1.0 mm

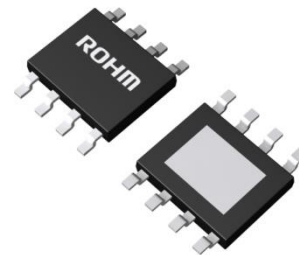

Applications

- Automotive Isolated Power Supplies (E-Comp, Inverter etc)
- Industrial Isolated Power Supplies

Typical Application Circuit

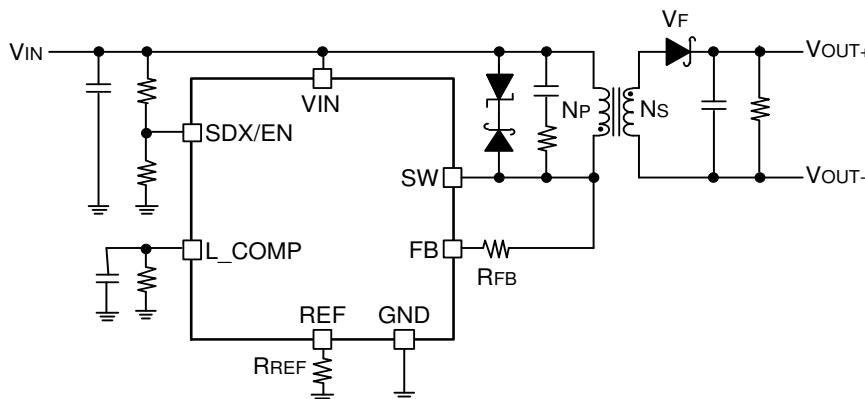

○Product structure : Silicon integrated circuit ○This product has no designed protection against radioactive rays.

Contents

General Description	1
Features.....	1
Key Specifications	1
Package.....	1
Applications	1
Typical Application Circuit.....	1
Contents	2
Pin Configuration	3
Pin Descriptions.....	3
Block Diagram	3
Description of Blocks	4
1 INTERNAL REGULATOR	4
2 Input Low Voltage Lock Out (UVLO)	4
3 Thermal Shutdown (TSD)	5
4 SW VOLTAGE DETECTION	5
5 SOFT START	5
6 PWM COMPARATOR	5
7 ADAPTIVE ON TIME CONTROLLER	5
8 Maximum Frequency Limit Function (MAX FREQ)	5
9 DRIVER	5
10 Nch MOSFET.....	5
11 LOAD COMPENSATION	6
12 Frequency Spectrum Spread (SPECTRUM SPREAD)	6
13 Over Current Protection (OCP), Battery Short Protection (BSP).....	6
14 Short Circuit Protection (SCP), REF Pin Open Protection (REFOPEN).....	7
Absolute Maximum Ratings	8
Thermal Resistance.....	8
Recommended Operating Conditions	8
Electrical Characteristics.....	9
Typical Performance Curves.....	10
Application Examples	18
1 Output Voltage	18
2 Transformer.....	20
3 Output Capacitor	22
4 Input Capacitor.....	22
5 Secondary Output Diode.....	23
6 Output Resistor and Output Zener Diode (Minimum Load Current)	23
7 Snubber Circuit	24
8 Setting of SDX/EN Pin Resistor	24
9 The Output Voltage Compensation Function by L_COMP Pin Resistor	25
10 The Influence to Frequency and Output Voltage for Each Load.....	26
I/O Equivalence Circuits.....	27
Operational Notes.....	28
Ordering Information.....	30
Marking Diagram	30
Physical Dimension and Packing Information	31
Revision History.....	32

Pin Configuration

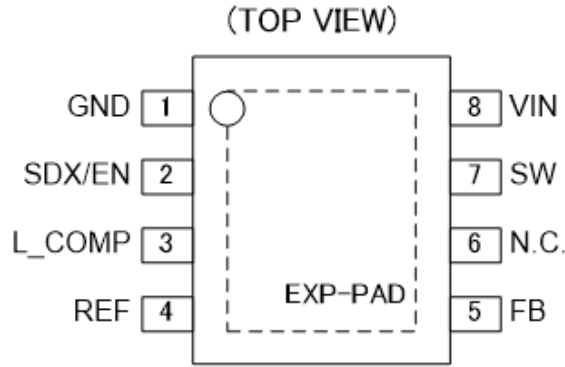

Pin Descriptions

Pin No.	Pin Name	Function
1	GND	GND pin
2	SDX/EN	Shutdown/Enable control pin
3	L_COMP	Setting pin of load current compensation value pin
4	REF	Output voltage setting pin
5	FB	Output voltage setting pin
6	N.C.	No Connect ^(Note 1)
7	SW	Switching output pin
8	VIN	Power supply input pin
-	EXP-PAD	Connect EXP-PAD to GND on PCB ^(Note 2)

(Note 1) The N.C pin does not have internal connection. Open the pin when mounting board.
 (Note 2) The EXP-Pad pin is connected to GND on the mounting board.

Block Diagram

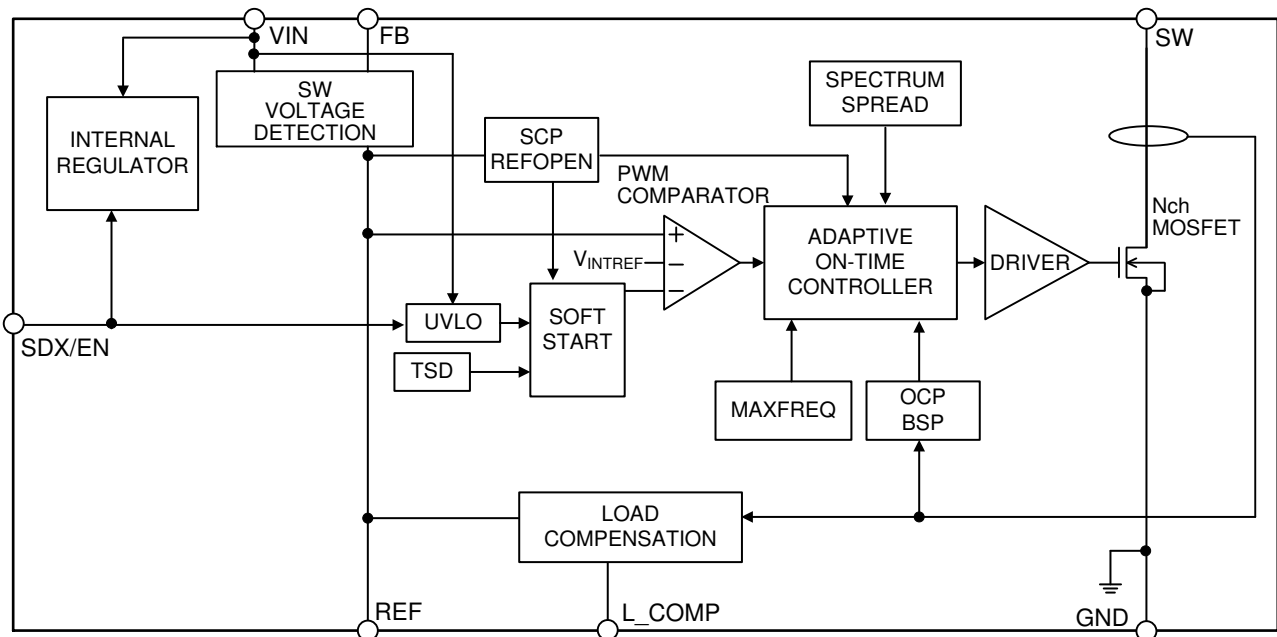

Description of Blocks

1 INTERNAL REGULATOR

This is regulator block for internal circuits.

This block shuts itself down at the shutdown status of SDX/EN pin voltage V_{SDX} or less.

When SDX/EN pin voltage rises above V_{SDX} , IC consumption current increases.

When SDX/EN pin voltage is above V_{EN1} , IC enters the enable status and starts switching operation.

The soft start function operates for t_{SS} period from switching start, and the output voltage rises slowly.

When SDX/EN pin voltage falls below V_{EN2} , IC enters the disable status and the switching operation is stopped.

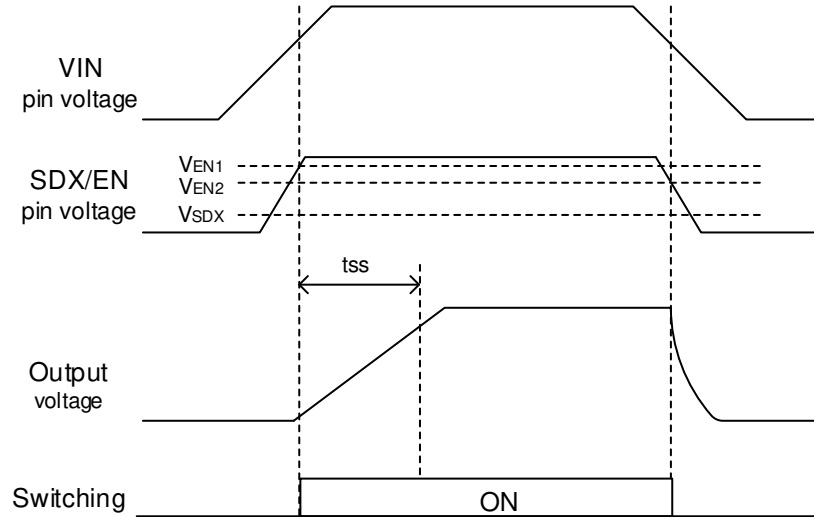

Figure 1. Startup and Stop Timing Chart

2 Input Low Voltage Lock Out (UVLO)

This is the protection function for the low input voltage of the VIN pin.

When VIN pin voltage falls below V_{UVLO1} , IC detects UVLO and stops switching operation.

When VIN pin voltage rises above V_{UVLO2} , IC starts switching operation and a soft start function operates during the period of t_{SS} .

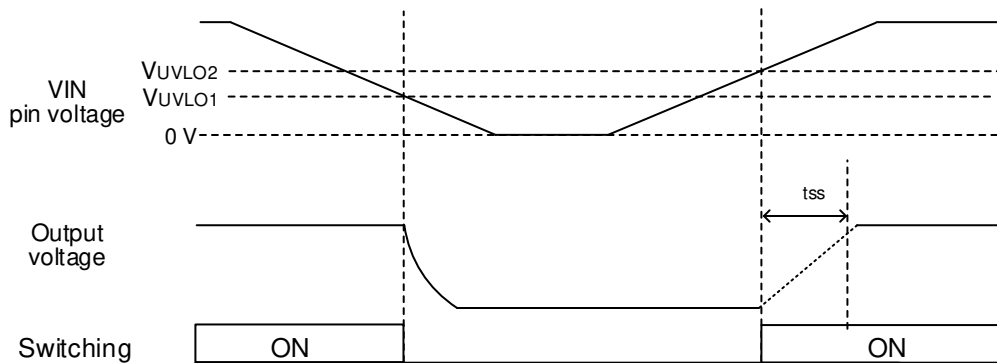

Figure 2. VIN UVLO Timing Chart

Description of Blocks – continued

3 Thermal Shutdown (TSD)

This block is the thermal shutdown circuit that prevents heat damage to the IC. When IC junction temperature rises more than 175 °C (Typ), IC stops switching operation. After that, when IC junction temperature falls IC restarts. The temperature hysteresis is 25 °C (Typ). The TSD function aims to protect itself. So IC junction temperature should be designed less than $T_{jmax} = 150$ °C. For that, it should not use as over temperature protection function of application.

4 SW VOLTAGE DETECTION

This block detects the flyback voltage generated in the SW pin. In turn-off of the transformer, this block converts current to flow from the FB pin into voltage by the resistance of the REF pin and the flyback voltage is detected by this REF pin voltage.

The IC controls REF pin voltage to be equivalent to V_{INTREF} .

5 SOFT START

When IC turns to enable status that SDX/EN pin voltage rises above V_{EN1} , the comparison voltage of the PWM COMPARATOR block increases gradually from 0 V to V_{INTREF} . PWM comparator voltage is constantly V_{INTREF} after soft start time passed.

This operation prevents from the output voltage overshooting. The soft start time is fixed to t_{SS} in the IC.

And, SCP protection is invalid for $t_{MASKSCP}$ period from start-up.

6 PWM COMPARATOR

This block compares REF pin voltage equivalent to feedback voltage of the output voltage with soft start voltage or reference voltage V_{INTREF} . This comparator output decides the ON timing.

Since it does not have error amplifier and constitutes a feedback loop by the comparator, IC enables fast control to load response during PWM operation.

7 ADAPTIVE ON TIME CONTROLLER

This block is ON time control block which uses original adapted ON-time control technology.

Stable load current:	IC operates in PWM operation by constant ON time control.
Fluctuating load current:	IC operates in the constant ON time control and fluctuate the switching frequency. It results from fast response.
Light load:	The switching frequency decreases and realizes a high efficiency by PFM operation during discontinuous mode.

When the load current fluctuates, IC operates within f_{SW_MAX} . IC raises the primary average current by shortening the off time. It results from increasing the secondary current and secondary output voltage is quickly stable.

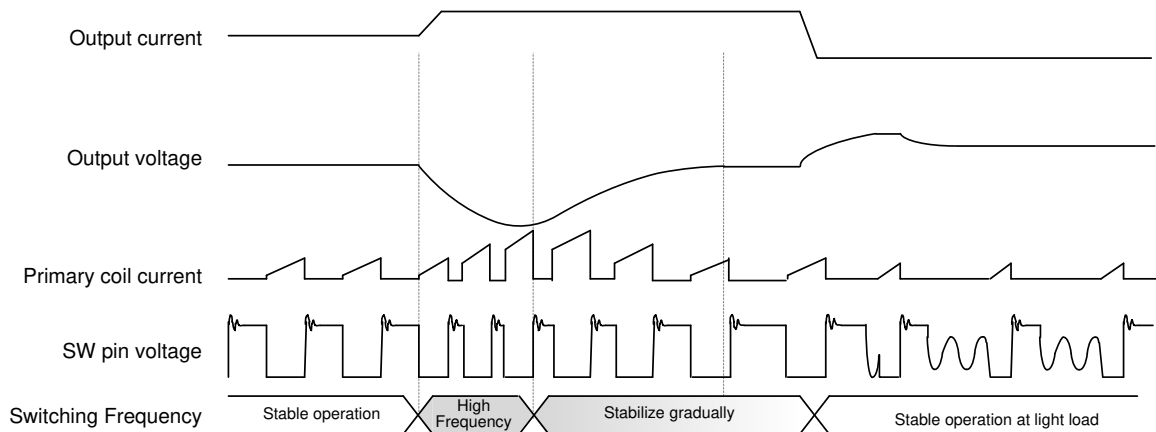

Figure 3. Load Current Response Timing Chart

8 Maximum Frequency Limit Function (MAX FREQ)

This function limits the maximum frequency. The switching frequency is instantly high at ON width control in start-up or load response. It may influence to EMI. For that, IC limits max frequency less than f_{SW_MAX} .

9 DRIVER

This is the block which drives Nch MOSFET for switching.

10 Nch MOSFET

This is Nch MOSFET for switching.

Description of Blocks – continued

11 LOAD COMPENSATION

This block compensates the decrease of output voltage caused by the change of V_F characteristic in the secondary output diode which is proportional to load current. It monitors the current flown to the switching MOSFET and a part of the current flows to the REF pin. The quantity of compensation determines by the external resistor and capacitor at the L_COMP pin and K_{L_COMP} which is coefficient for SW current. For that, as the current flown from the FB pin to the external resistor of the REF pin decreases, the output voltage decrease is compensated.

12 Frequency Spectrum Spread (SPECTRUM SPREAD)

This is the function to spread switching frequency.
The frequency spreading in the range of $\pm 5\%$ contributes to low EMI.

13 Over Current Protection (OCP), Battery Short Protection (BSP)

This function is over current protection of the MOSFET.

13.1 Over Current Protection (OCP)

When the switching MOSFET is on, as the primary transformer peak current becomes I_{LIMIT} or more, IC detects the over current and the switching MOSFET is turned off. Because IC detects OCP per switching cycles, ON duty is limited and the output voltage drops. In addition, to prevent miss detection by turn ON surge, the detection of OCP is invalid for t_{ON_MIN} after the switching MOSFET is turned on.

After IC detects OCP, switching MOSFET is turn off after a delay time. When V_{IN} voltage is increased, I_{LIMIT} is higher by the rise of current slope. ΔI_{LIMIT} depends on L_P value of transformer.

$$\Delta I_{LIMIT} = V_{IN} \times t_{DELAY} / L_P$$

t_{DELAY} : OCP detection delay time

L_P : Primary inductance

t_{DELAY} is always 0.2 μs or less.

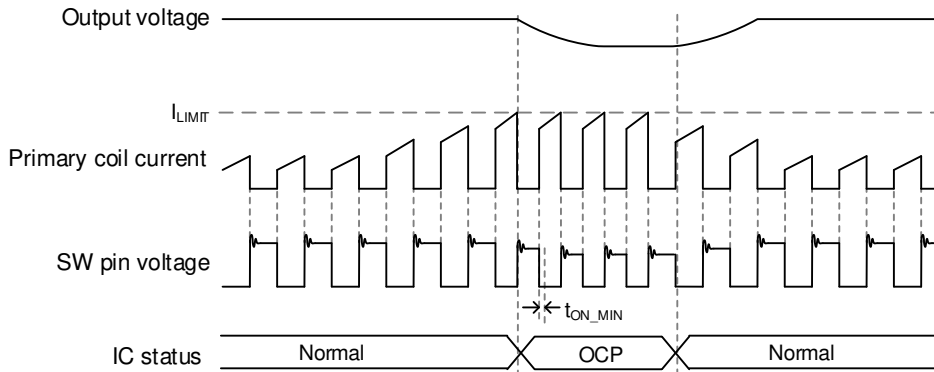

Figure 4. OCP Timing Chart

13.2 Battery Short Protection (BSP)

In the case of increasing peak current by CCM (Continuous Conduction Mode) operation such as the short of the transformer winding or output short of secondary, large current over I_{LIMIT} is flown to the switching MOSFET. To prevent this phenomenon, IC is built-in BSP function. When SW pin current becomes I_{BSP} or more at the switching MOSFET ON, the IC detects BSP. By this function, the switching operation is stopped in the period of t_{BSP} . After it passes t_{BSP} , IC recovers switching operation without soft-start function. When BSP state continues, IC stops switching operation by SCP protection because output voltage is low. BSP is affected by the delay time (t_{DELAY}) the same as OCP, and I_{BSP} increases according to V_{IN} voltage. Also, when primary transformer is short, the function is operated.

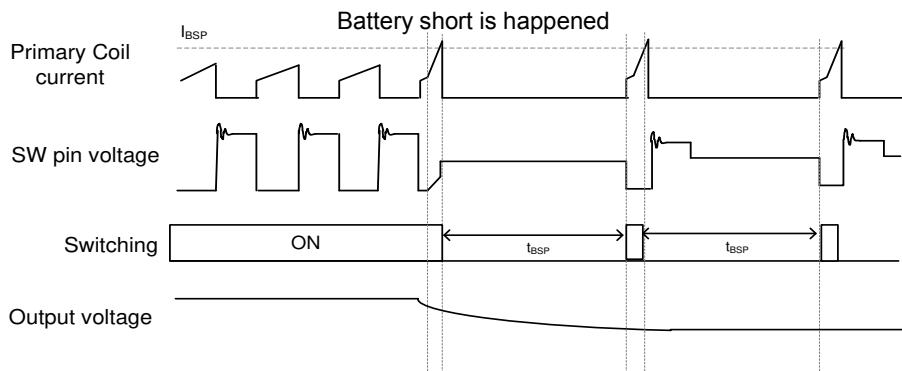

Figure 5. BSP Timing Chart

Description of Blocks – continued

14 Short Circuit Protection (SCP), REF Pin Open Protection (REFOPEN)

This is the block of the short protection and the open protection of the REF pin.

14.1 Short Circuit Protection (SCP)

As IC converts the primary flyback voltage to REF pin voltage, IC detects secondary output status. When secondary output voltage drops, REF pin voltage also drops. When REF pin voltage is below V_{SCP} , IC detects SCP. When the detection continues for t_{MASK} , the switching operation is stopped. After the time of $t_{RESTART}$ passes from the stop, IC restarts with soft start function. To prevent SCP miss detection, the detection of SCP is invalid for $t_{MASKSCP}$ at start-up. When REF voltage is lower than V_{SCP} for $t_{MASKSCP}$ from start-up, IC stops switching for $t_{RESTART}$.

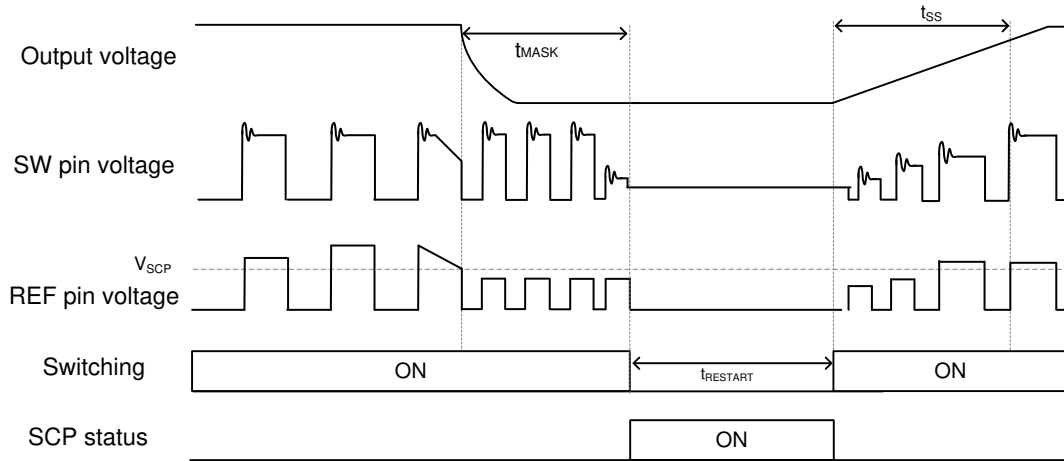

Figure 6. SCP Timing Chart

14.2 REF Pin Open Protection (REFOPEN)

The REF pin detects the secondary output voltage status from the primary flyback voltage. When the REF pin is open, output status is not detected, and switching MOSFET may occur malfunction. Therefore, when REF pin voltage is above V_{REFOP} , the IC detects REFOPEN protection. When the detection continues for t_{MASK} , the switching operation is stopped. After the time of $t_{RESTART}$ from the stop, IC restarts with soft start function. When auto recovery, IC operates for t_{MASK} from start-up. When REF pin voltage is above V_{REFOP} for t_{MASK} , IC stops switching for $t_{RESTART}$.

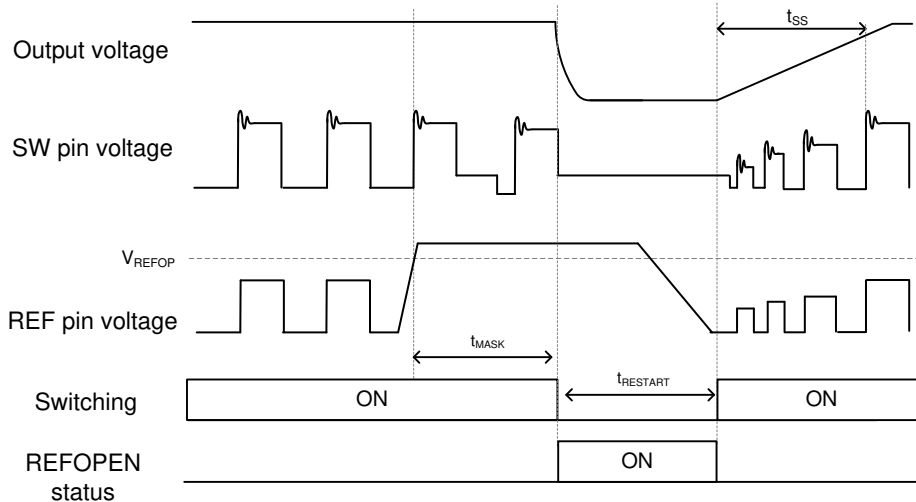

Figure 7. REFOPEN Protection Timing Chart

Absolute Maximum Ratings (Ta = 25 °C)

Parameter	Symbol	Rating	Unit
VIN Pin Voltage	V _{IN}	-0.3 to +45	V
SW Pin Voltage	V _{SW}	-0.3 to +62	V
SDX/EN Pin Voltage	V _{SDX/EN}	-0.3 to +45	V
FB Pin Voltage	V _{FB}	-0.3 to +45	V
REF Pin Voltage	V _{REF}	-0.3 to +7	V
L_COMP Pin Voltage	V _{L_COMP}	-0.3 to +7	V
Maximum Junction Temperature	T _{jmax}	150	°C
Storage Temperature Range	T _{stg}	-55 to +150	°C

Caution 1: Operating the IC over the absolute maximum ratings may damage the IC. The damage can either be a short circuit between pins or an open circuit between pins and the internal circuitry. Therefore, it is important to consider circuit protection measures, such as adding a fuse, in case the IC is operated over the absolute maximum ratings.

Caution 2: Should by any chance the maximum junction temperature rating be exceeded the rise in temperature of the chip may result in deterioration of the properties of the chip. In case of exceeding this absolute maximum rating, design a PCB with thermal resistance taken into consideration by increasing board size and copper area so as not to exceed the maximum junction temperature rating.

Thermal Resistance (Note 1)

Parameter	Symbol	Thermal Resistance (Typ)		Unit
		1s (Note 3)	2s2p (Note 4)	
HTSOP-J8				
Junction to Ambient	θ_{JA}	206.4	45.2	°C/W
Junction to Top Characterization Parameter (Note 2)	Ψ_{JT}	21	13	°C/W

(Note 1) Based on JESD51-2 A (Still-Air).

(Note 2) The thermal characterization parameter to report the difference between junction temperature and the temperature at the top center of the outside surface of the component package.

(Note 3) Using a PCB board based on JESD51-3.

(Note 4) Using a PCB board based on JESD51-5, 7.

Layer Number of Measurement Board	Material	Board Size
Single	FR-4	114.3 mm x 76.2 mm x 1.57 mmt

Top	
Copper Pattern	Thickness
Footprints and Traces	70 μ m

Layer Number of Measurement Board	Material	Board Size	Thermal Via (Note 5)	
			Pitch	Diameter
4 Layers	FR-4	114.3 mm x 76.2 mm x 1.6 mmt	1.20 mm	Φ 0.30 mm

Top		2 Internal Layers		Bottom	
Copper Pattern	Thickness	Copper Pattern	Thickness	Copper Pattern	Thickness
Footprints and Traces	70 μ m	74.2 mm x 74.2 mm	35 μ m	74.2 mm x 74.2 mm	70 μ m

(Note 5) This thermal via connect with the copper pattern of layers 1, 2, and 4. The placement and dimensions obey a land pattern.

Recommended Operating Conditions

Parameter	Symbol	Min	Typ	Max	Unit	Conditions
Operation Power Supply Voltage Range	V _{IN}	3.4	12.0	42.0	V	VIN pin voltage
Operation Voltage Range	V _{SW}	-	-	60	V	SW pin Voltage
Operation Temperature	T _{opr}	-40	-	+125	°C	
REF Pin Resistor	R _{REF}	-	2.7	-	k Ω	External resistor value (Note 6)
L_COMP Voltage Range	V _{L_COMP}	-	-	1.00	V	L_COMP pin voltage
VIN-GND Capacitor	C _{VIN}	10	-	-	μ F	

(Note 6) Set the REF resistor value of 2.7 k Ω (Typ). Choose the resistance accuracy for an output voltage accuracy.

Electrical Characteristics (Unless otherwise Tj = -40 °C to +150 °C, V_{IN} = 12 V, V_{SDX/EN} = 2.5 V)

Parameter	Symbol	Min	Typ	Max	Unit	Conditions
Power Supply Block						
Current at Shutdown	I _{ST}	-	0	10	μA	SDX/EN = 0.3 V Tj ≤ 125 °C
Operating Current at No Switching	I _{CC}	0.43	1.00	1.70	mA	REF = 0.6 V
UVLO Detection Voltage 1	V _{UVLO1}	3.00	3.20	3.40	V	At the VIN pin falling
UVLO Detection Voltage 2	V _{UVLO2}	3.20	3.40	3.60	V	At the VIN pin rising
UVLO Voltage Hysteresis	V _{UVLO_HYS}	0.12	0.20	0.28	V	
Shutdown and Enable Control Block						
Shutdown Voltage at the SDX/EN Pin	V _{SDX}	-	-	0.3	V	
Enable Voltage 1	V _{EN1}	1.90	2.00	2.10	V	At the SDX/EN pin rising
Enable Voltage 2	V _{EN2}	1.60	1.80	2.00	V	At the SDX/EN pin falling
Enable Voltage Hysteresis	V _{EN_HYS}	0.14	0.20	0.26	V	
SDX/EN Pin Current	I _{SDX/EN}	0.50	1.00	2.00	μA	SDX/EN = 2.5 V
SDX/EN Pin Pull-down Resistance	R _{SDX/EN}	1250	2500	3750	kΩ	
Reference Voltage Block						
Reference Voltage	V _{INTREF}	0.525	0.540	0.555	V	
REF Pin Current	I _{REF}	140	200	260	μA	R _{REF} = 2.7 kΩ
Switching Block						
On Resistance	R _{ON}	-	0.40	0.80	Ω	SW-GND I _{SW} = 50 mA
Over Current Detection Current	I _{LIMIT}	2.08	2.60	3.12	A	
BSP Detection Current	I _{BSP}	2.39	3.38	4.52	A	
Averaging Switching Frequency	f _{SW}	300	363	430	kHz	At PWM operation (Duty = 40 %)
Maximum Switching Frequency	f _{SW_MAX}	-	-	498	kHz	
On Time	t _{ON}	0.962	1.102	1.270	μs	At PWM operation (Duty = 40 %)
Minimum ON Time	t _{ON_MIN}	120	250	380	ns	
Maximum OFF Time	t _{OFF_MAX}	25	35	45	μs	
Soft Start Time	t _{SS}	3.0	5.0	7.0	ms	From switching start to V _{INTREF} x 90 %
Protection Function Block						
Short Protection Detection Voltage	V _{SCP}	0.20	0.30	0.40	V	
REFOPEN Protection Detection Voltage	V _{REFOP}	0.60	0.70	0.80	V	
SCP/REFOPEN Detection Mask Time	t _{MASK}	1.05	1.50	1.95	ms	
SCP Mask Time at Start-up	t _{MASKSCP}	5.25	7.50	9.75	ms	
BSP Stop Time at Detection	t _{BSP}	262	375	488	μs	
Restart Time	t _{RESTART}	18.0	24.0	30.0	ms	
Load Compensation Block						
KL_COMP (Compensation Coefficient of REF Current for SW Current)	K _{L_COMP}	0.090	0.128	0.166	%/MΩ	(Note 1)

(Note 1) Load compensation current coefficient is the coefficient which compensates output voltage decrease for output current. It sets by L_COMP pin resistor. It is tested at R_{L_COMP} = 10 kΩ.

Typical Performance Curves

(Reference Data)

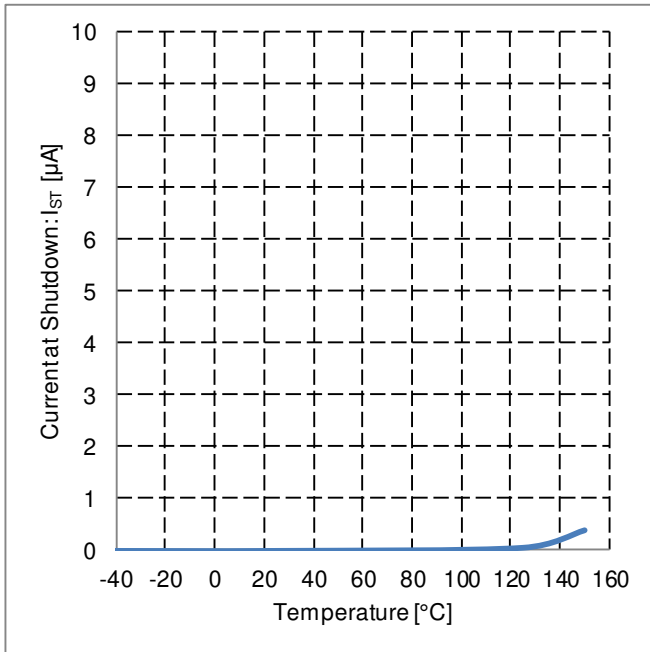

Figure 8. Current at Shutdown vs Temperature

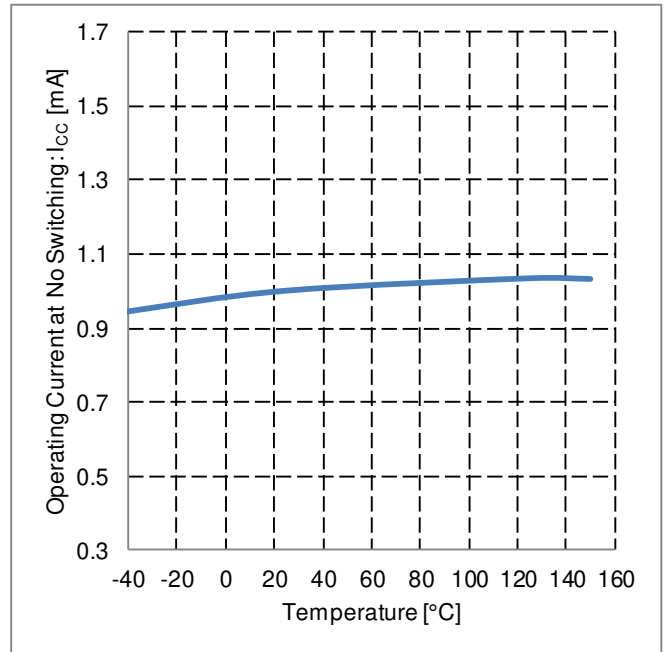

Figure 9. Operating Current at No Switching vs Temperature

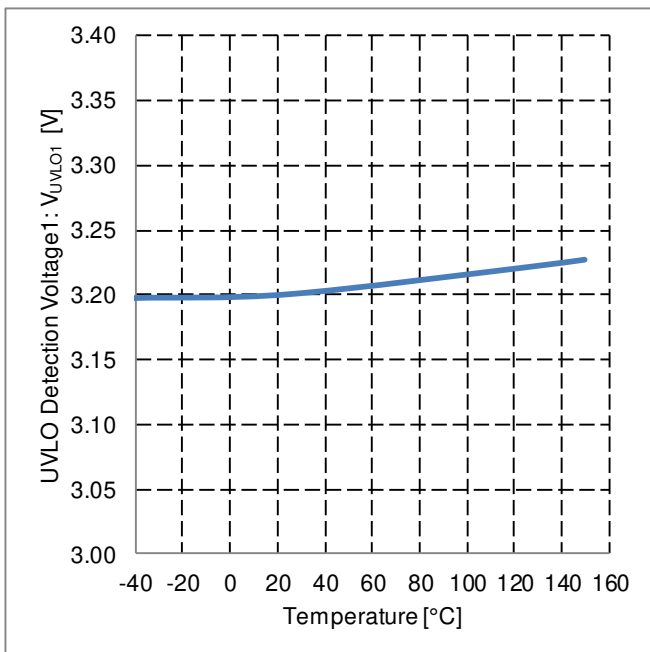

Figure 10. UVLO Detection Voltage1 vs Temperature

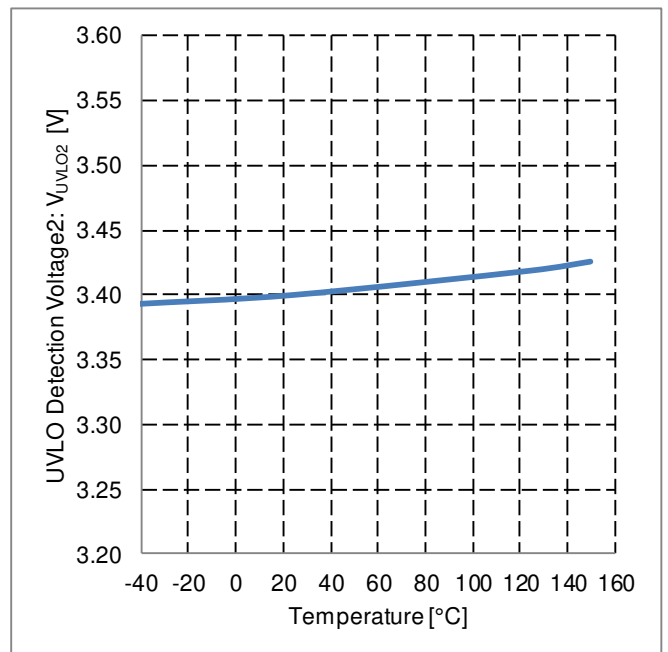

Figure 11. UVLO Detection Voltage2 vs Temperature

Typical Performance Curves – continued

(Reference Data)

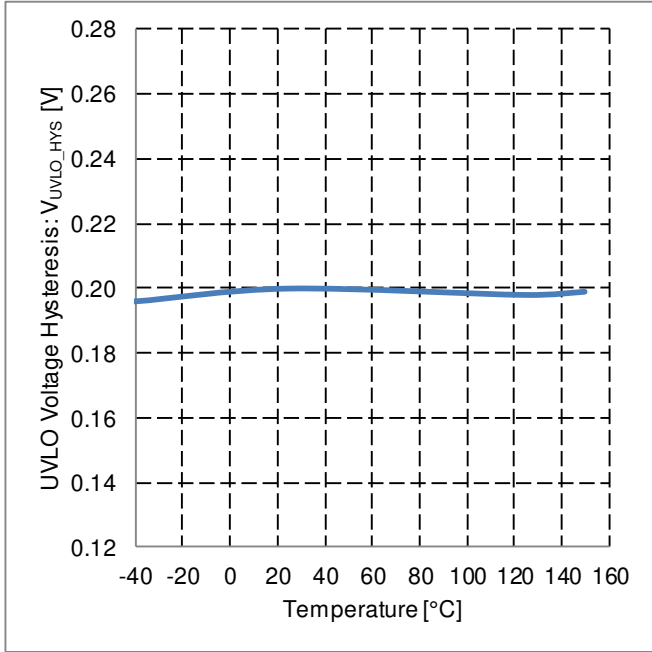

Figure 12. UVLO Voltage Hysteresis vs Temperature

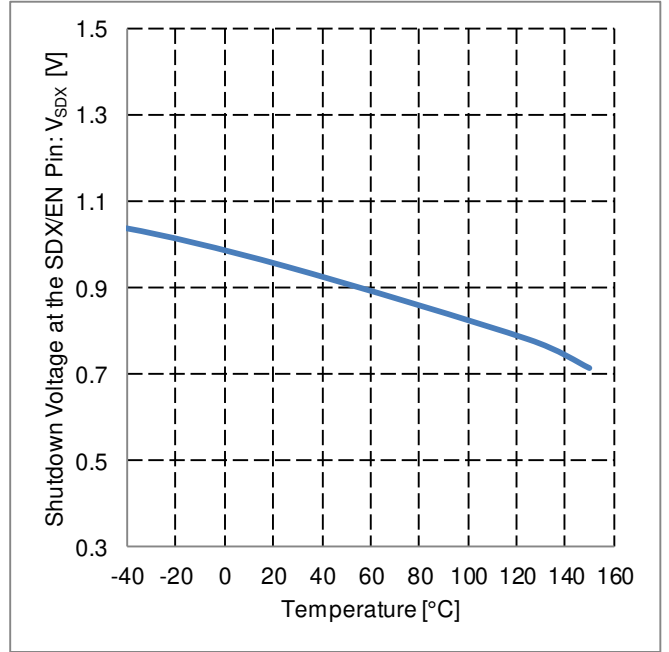

Figure 13. Shutdown Voltage at the SDX/EN Pin vs Temperature

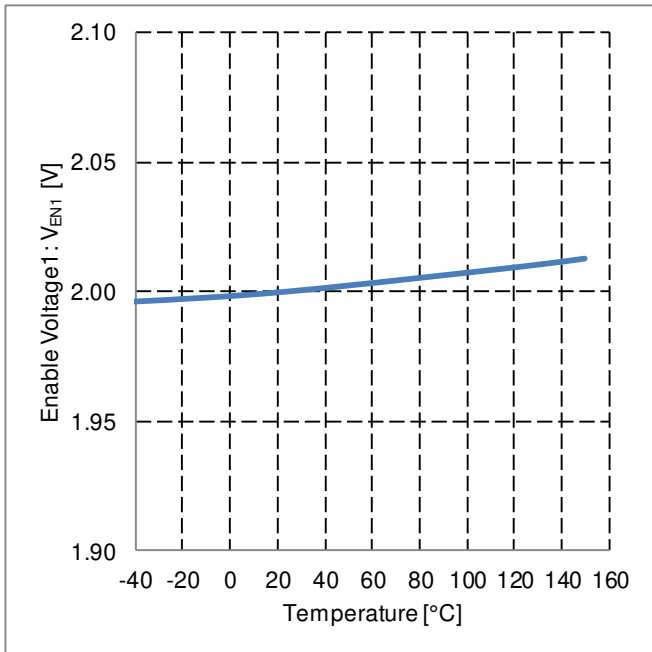

Figure 14. Enable Voltage1 vs Temperature

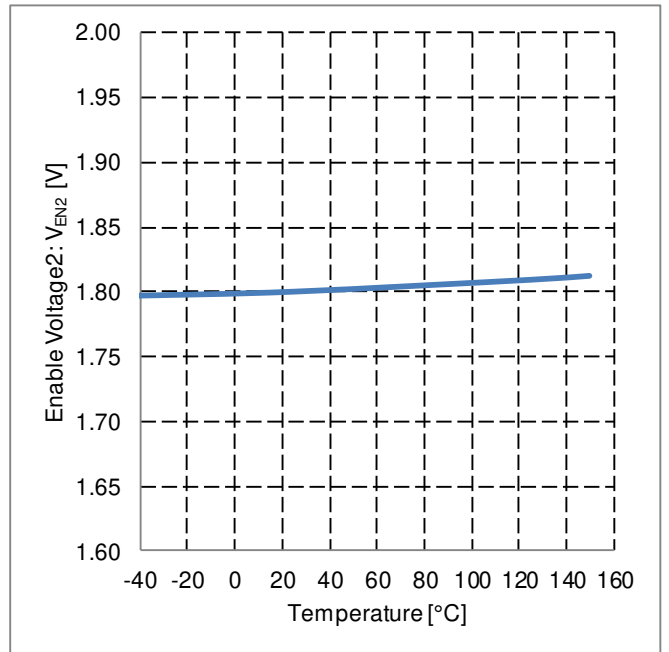

Figure 15. Enable Voltage2 vs Temperature

Typical Performance Curves – continued

(Reference Data)

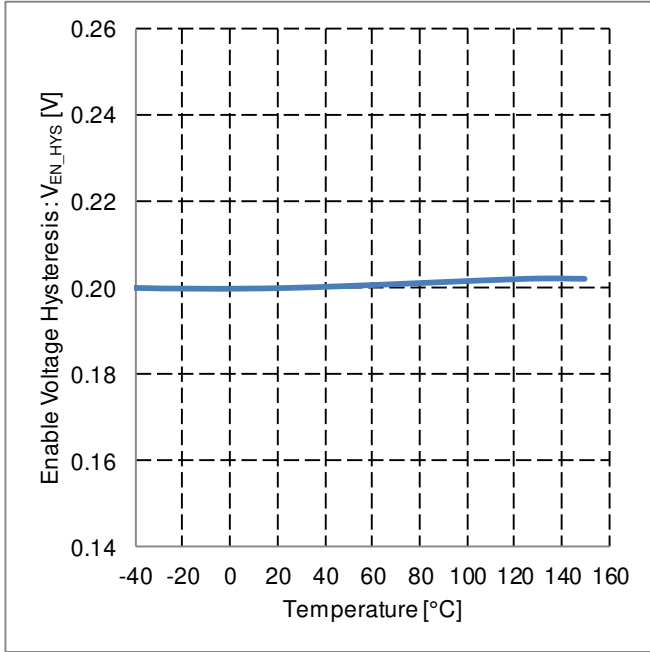

Figure 16. Enable Voltage Hysteresis vs Temperature

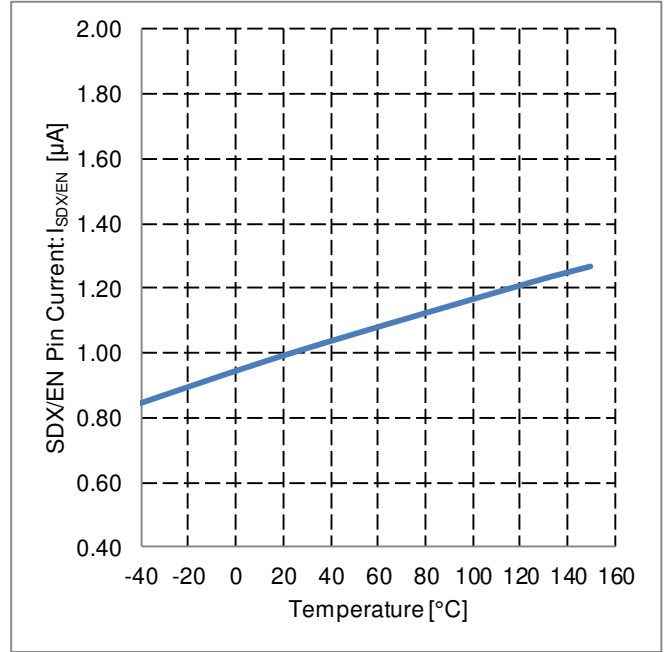

Figure 17. SDX/EN Pin Current vs Temperature

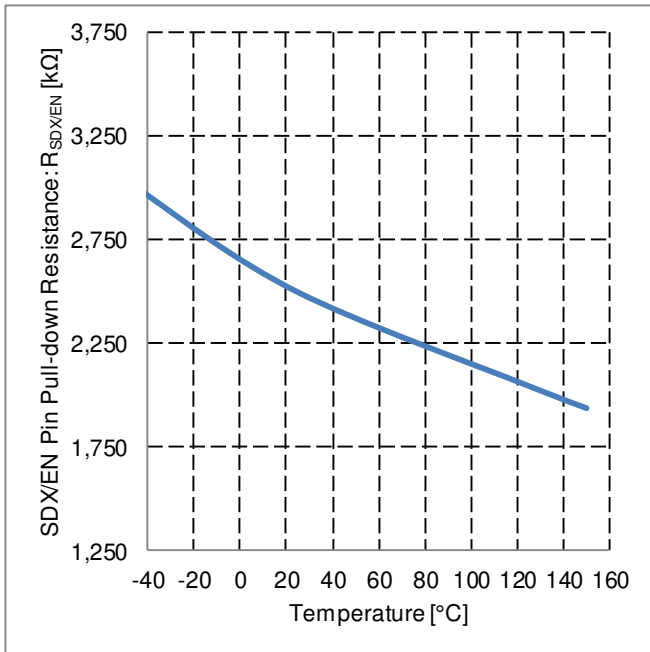

Figure 18. SDX/EN Pin Pull-down Resistance vs Temperature

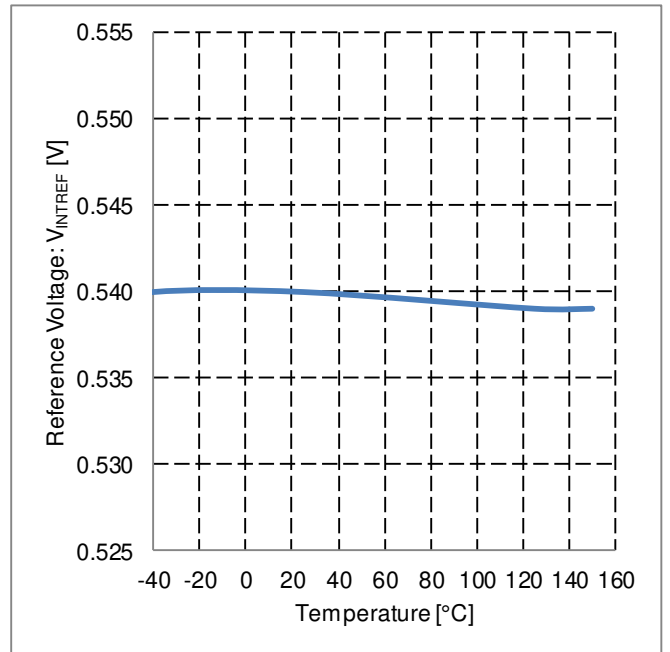

Figure 19. Reference Voltage vs Temperature

Typical Performance Curves – continued

(Reference Data)

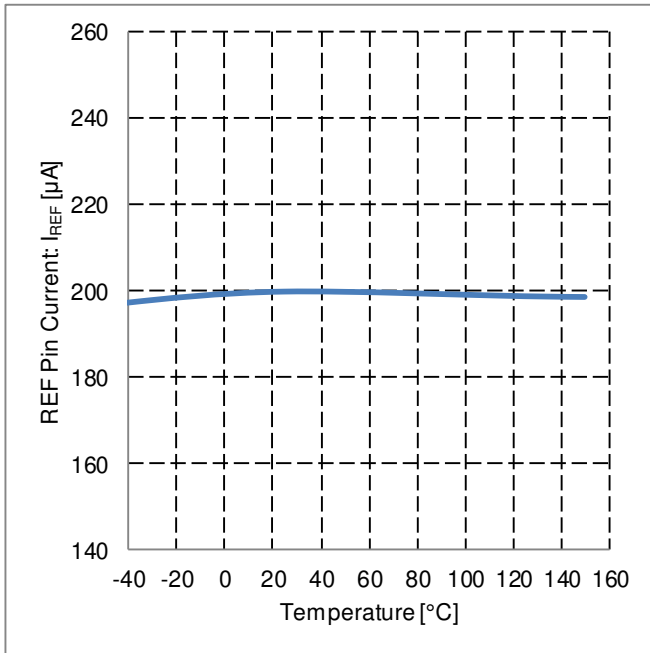

Figure 20. REF Pin Current vs Temperature

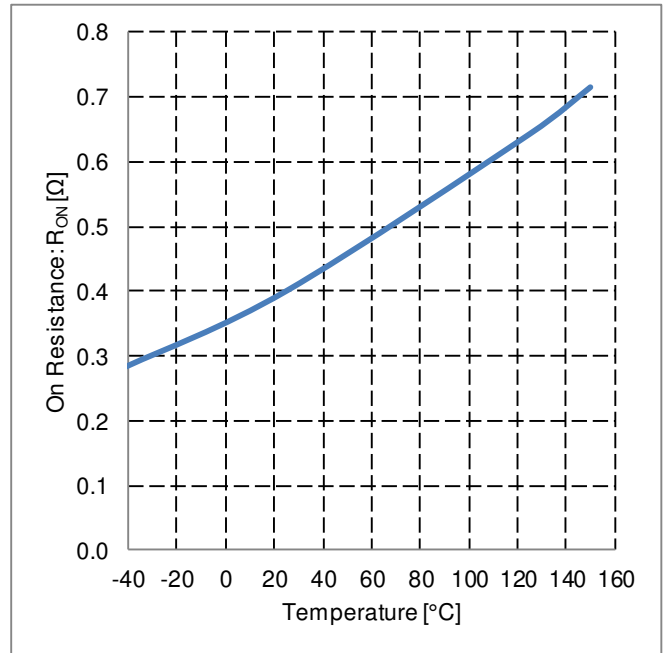

Figure 21. On Resistance vs Temperature

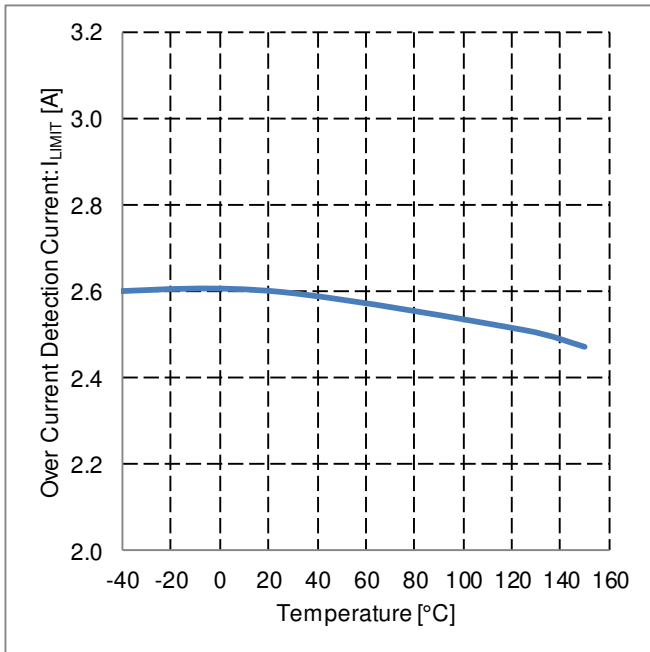

Figure 22. Over Current Detection Current vs Temperature

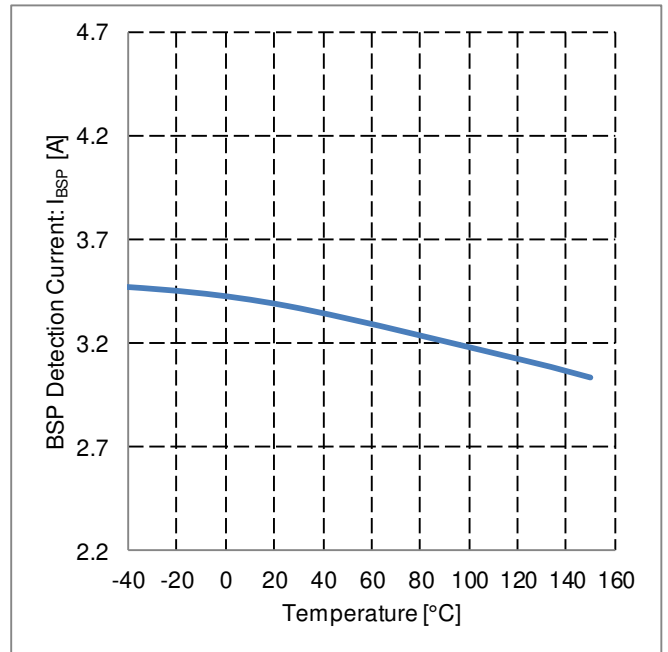

Figure 23. BSP Detection Current vs Temperature

Typical Performance Curves – continued

(Reference Data)

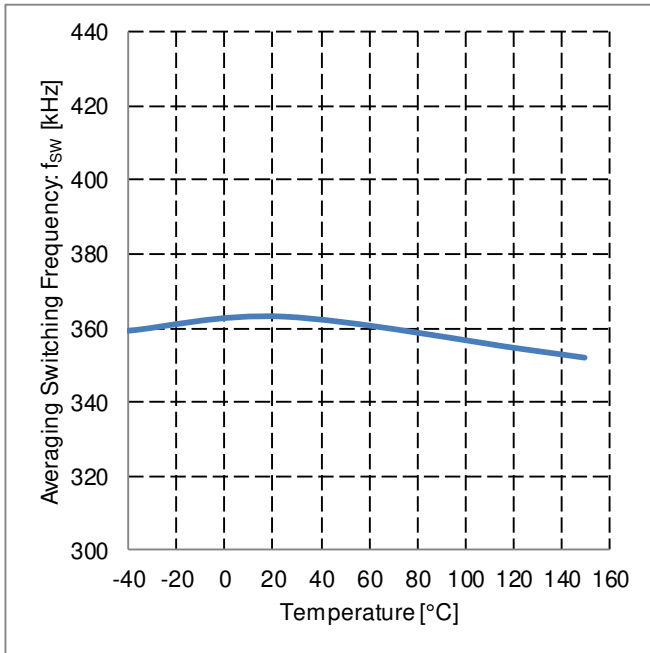

Figure 24. Averaging Switching Frequency vs Temperature

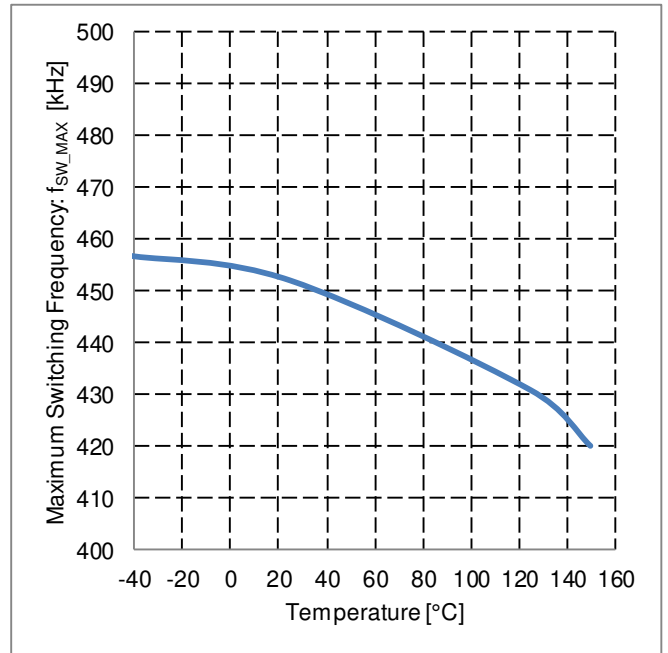

Figure 25. Maximum Switching Frequency vs Temperature

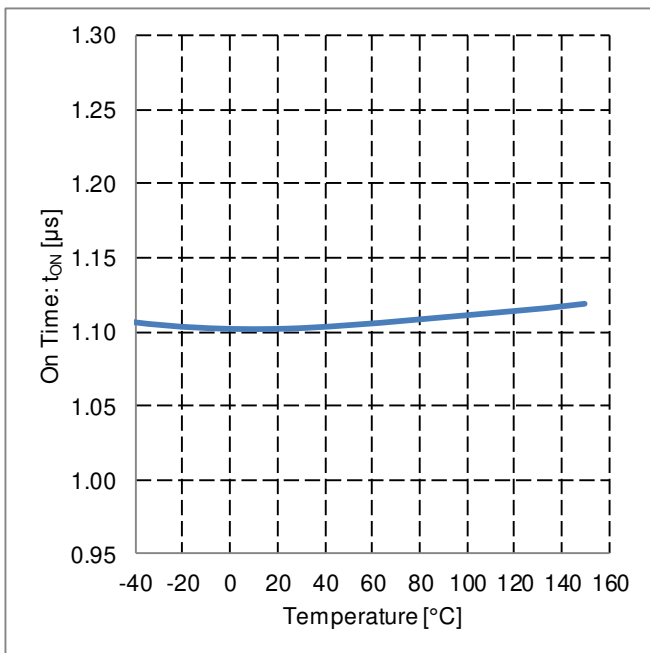

Figure 26. On Time vs Temperature
(Duty = 40 %, f_{sw} = 363 kHz)

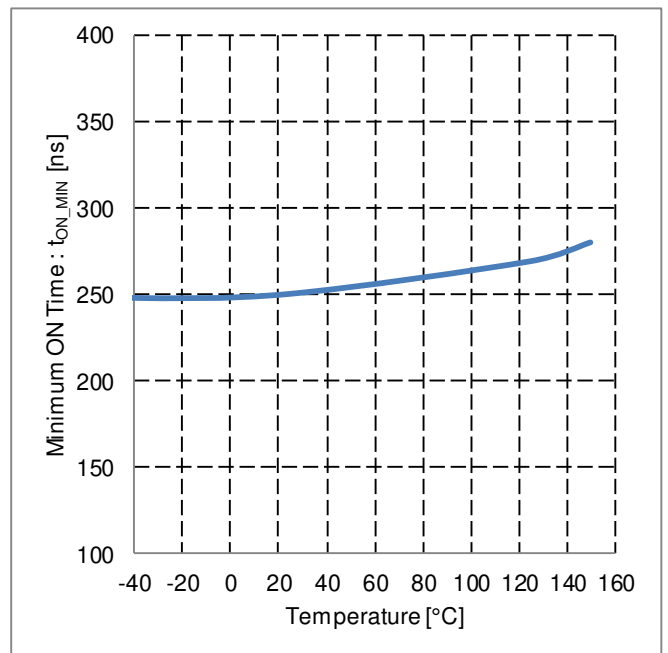

Figure 27. Minimum ON Time vs Temperature

Typical Performance Curves – continued

(Reference Data)

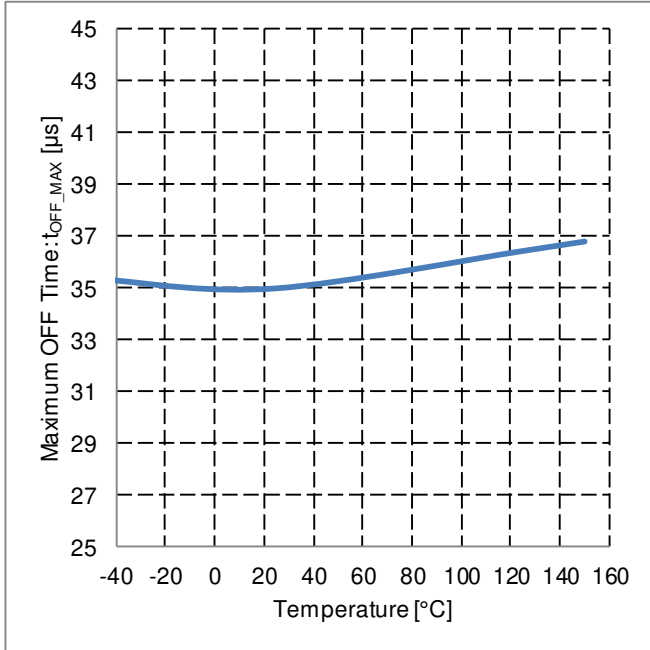

Figure 28. Maximum OFF Time vs Temperature

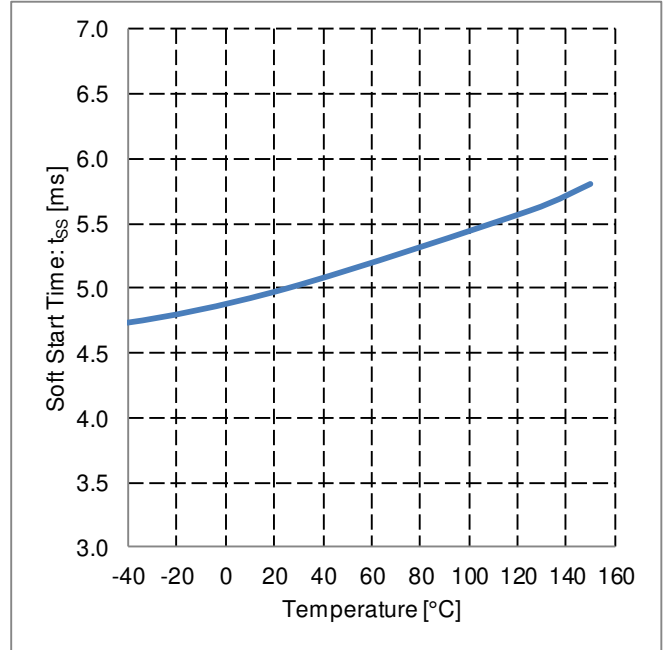

Figure 29. Soft Start Time vs Temperature

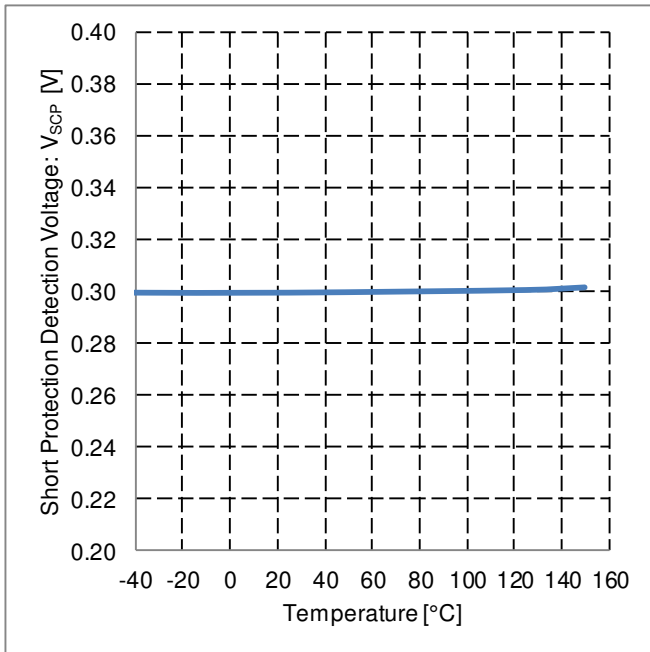

Figure 30. Short Protection Detection Voltage vs Temperature

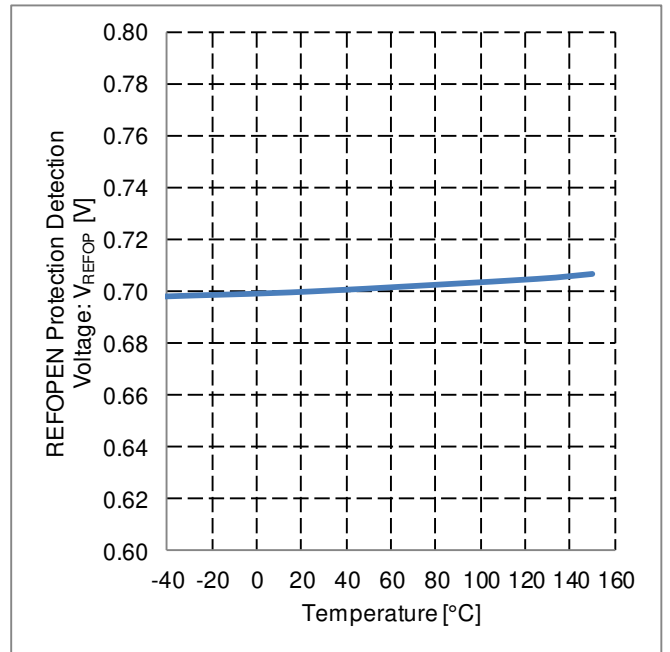

Figure 31. REFOPEN Protection Detection Voltage vs Temperature

Typical Performance Curves – continued

(Reference Data)

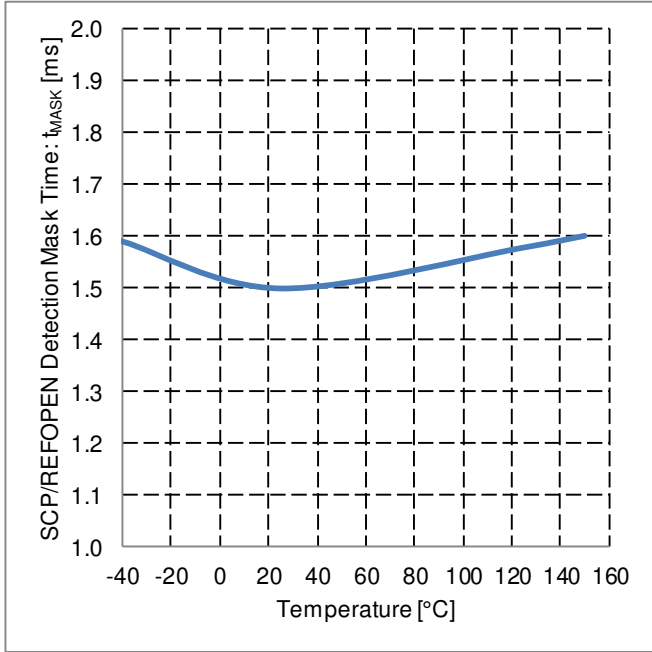

Figure 32. SCP/REFOPEN Detection Mask Time vs Temperature

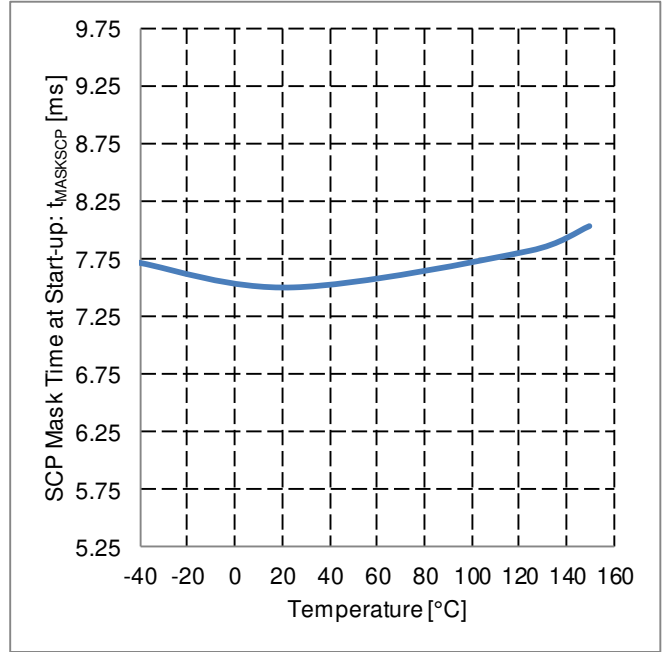

Figure 33. SCP Mask Time at Start-up vs Temperature

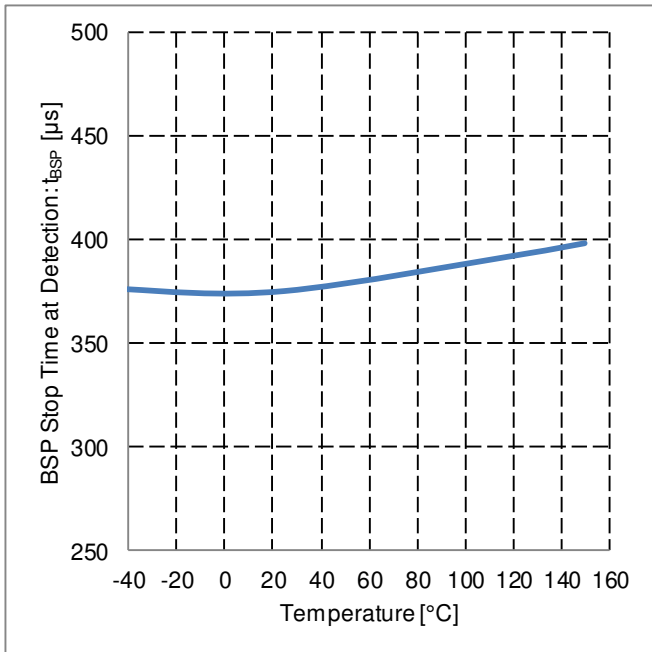

Figure 34. BSP Stop Time vs Temperature

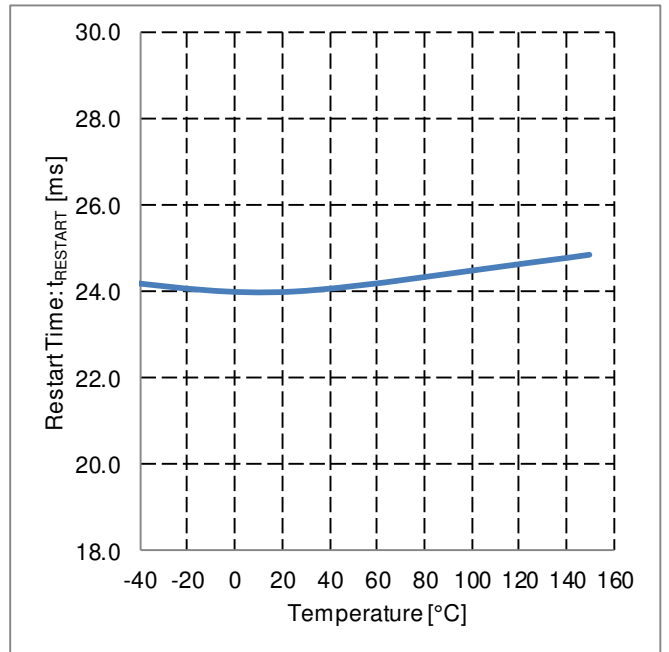

Figure 35. Restart Time vs Temperature

Typical Performance Curves – continued

(Reference Data)

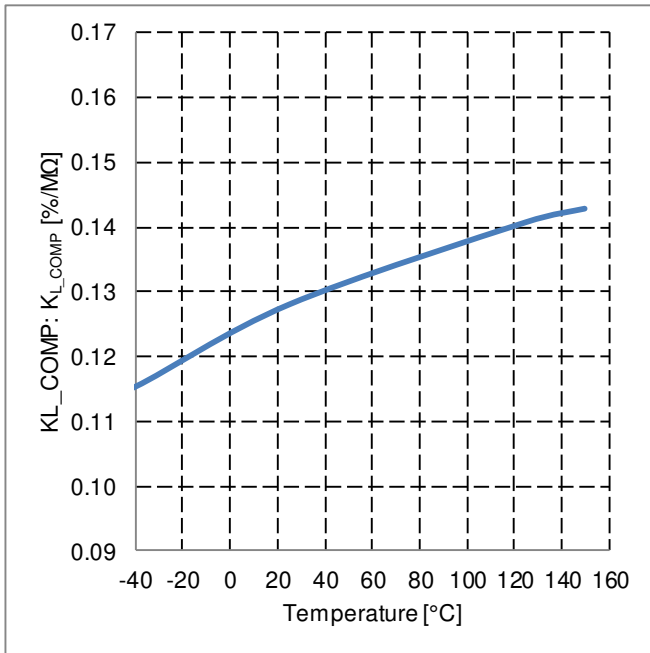

Figure 36. KL_COMP vs Temperature

Application Examples

1 Output Voltage

When the internal switching MOSFET is off, SW pin voltage "V_{SW}" is higher than V_{IN} pin voltage. The secondary output voltage is calculated by the primary flyback voltage, which is described by the difference between this SW pin voltage and V_{IN} pin voltage. SW pin voltage at turn off is calculated by the following formula.

$$V_{SW} = V_{IN} + \frac{N_P}{N_S} \times (V_{OUT} + V_F) \quad [M]$$

where:

V_{SW} is SW pin voltage.

V_{IN} is V_{IN} pin voltage.

N_P is the number of winding at the primary transformer.

N_S is the number of winding at the secondary transformer.

V_{OUT} is the Output voltage.

V_F is the forward voltage of the secondary output diode.

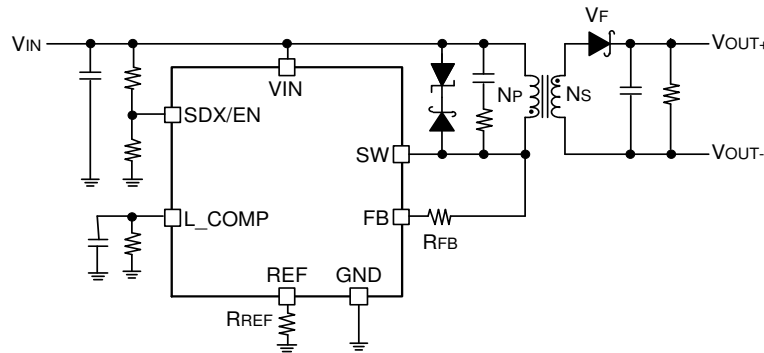

Figure 37. Application Block Diagram

The external resistor R_{FB} between the FB pin and the SW pin converts the primary flyback voltage into FB pin inflow current I_{FB}. I_{FB} is calculated by the formula below because FB pin voltage is nearly equal to V_{IN} pin voltage by IC's internal circuit.

$$I_{FB} = \frac{V_{SW} - V_{FB}}{R_{FB}} = \frac{V_{IN} + \frac{N_P}{N_S} \times (V_{OUT} + V_F) - V_{FB}}{R_{FB}} = \frac{\frac{N_P}{N_S} \times (V_{OUT} + V_F)}{R_{FB}} \quad [A]$$

where:

I_{FB} is FB pin inflow current.

V_{FB} is FB pin voltage.

R_{FB} is the external resistor between the FB pin and the SW pin.

1 Output Voltage – continued

FB current I_{RFB} flows to the REF pin and the external resistor R_{REF} between the REF pin and the GND pin. REF pin voltage is calculated by below equation.

$$V_{REF} = \frac{R_{REF}}{R_{FB}} \times \frac{N_P}{N_S} \times (V_{OUT} + V_F) \quad [V]$$

where:

V_{REF} is REF pin voltage.

R_{REF} is the external resistor between the REF pin and the GND pin.

R_{REF} resistor is necessary to set 2.7 kΩ because REF pin current is equivalent to I_{REF} and REF pin voltage is equivalent to V_{INTREF} .

$$R_{REF} = \frac{0.54 V}{200 \mu A} = 2.7 k\Omega$$

Therefore, REF pin resistor is always needed to set $R_{REF} = 2.7 k\Omega$.

REF pin voltage is input to the comparator with the reference voltage V_{INTREF} in the IC. By the internal circuit, REF pin voltage is equal to the reference voltage. Therefore, the output voltage and REF pin voltage is calculated by the formula below.

$$V_{OUT} = \frac{R_{FB}}{R_{REF}} \times \frac{N_S}{N_P} \times V_{INTREF} - V_F \quad [V]$$

To be shown to the equation, the output voltage is set by the number of winding ratio of the primary and secondary transformer (N_P/N_S) and the resistance ratio of R_{FB} and R_{REF} . According to the relational expression in above, the external resistor R_{FB} between the FB pin and the SW pin is calculated by the formula below.

$$R_{FB} = \frac{R_{REF}}{V_{INTREF}} \times \frac{N_P}{N_S} \times (V_{OUT} + V_F) \quad [\Omega]$$

The ESR of the transformer on the secondary side as well as V_F causes the output voltage drop.

And, when transformer coupling is low, the N_P/N_S turns ratio changes and output voltage is lower than the setting voltage. Therefore, adjust the output voltage by actual evaluation of power supply.

Application Examples – continued

2 Transformer

2.1 The Determine of Winding Ratio N_P / N_S

The winding ratio is the parameter for setting output voltage, Max output power, Duty, SW pin voltage.
The duty of flyback converter is calculated by the following equation:

$$Duty = \frac{\frac{N_P}{N_S} \times (V_{OUT} + V_F)}{V_{IN} + \frac{N_P}{N_S} \times (V_{OUT} + V_F)} \quad [\%]$$

N_P is the Primary transformer winding

N_S is the Secondary transformer winding

V_{OUT} is the Output voltage

V_F is the forward voltage of secondary output diode

V_{IN} is VIN pin voltage

The winding ratio is calculated by below equation.

$$\frac{N_P}{N_S} = \frac{D_{TYP}}{1 - D_{TYP}} \times \frac{V_{IN}}{V_{OUT} + V_F}$$

D_{TYP} is the Duty of VIN voltage (Typ)

In the middle VIN voltage of usual operating range, it recommends that D_{TYP} is set from 30 % to 50 %.

First, it recommends to set $D_{TYP} = 40\%$. The winding ratio is limited by the maximum duty (D_{MAX}) in minimum input voltage condition. D_{MAX} given by the formula below must be not over 70 %. When duty is over 70 %, change D_{TYP} to be lower. If Duty is over 70 %, OFF time is short and the output voltage may change due to the shift in flyback voltage detection.

$$\frac{N_P}{N_S} = \frac{D_{MAX}}{1 - D_{MAX}} \times \frac{V_{IN(Min)}}{V_{OUT(Max)} + V_{F(Max)}}$$

where:

D_{MAX} is the Maximum duty of minimum VIN voltage condition

$V_{OUT(Max)}$ is the Maximum output voltage

$V_{F(Max)}$ is the Maximum forward voltage (V_F) of Secondary diode

Flyback voltage is calculated by below calculation.

$$V_{OR} = (V_{OUT} + V_F) \times \frac{N_P}{N_S} \quad [V]$$

SW pin voltage calculated below must be set so that the withstand voltage is not exceeded.

$$V_{SW} = V_{IN(Max)} + V_{OR} + V_{SURGE} \quad [V]$$

For example, when it has the delating of 90 % for SW pin voltage, SW pin voltage is needed to be less than the value which calculated below.

$$V_{SW} = 60 V \times (100\% - 10\%) = 54 V$$

In the case of $V_{IN(Max)}=30 V$ and $V_{OR}=10 V$, V_{SURGE} voltage is needed to be less than 14 V. This value is calculated below.

$$54 V - (30 V + 10 V) = 14 V$$

V_{SURGE} is occurred by the leakage of transformer. If V_{SURGE} is higher, it needs to decrease the voltage by re-designing transformation structure or snubber circuit adjustment.

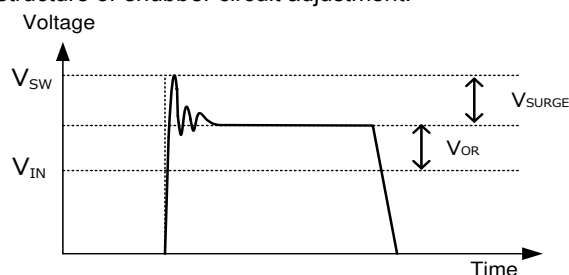

Figure 38. SW Waveform

When designed transformer, temporarily set winding ratio to satisfy above. When the winding ratio is decided, R_{FB} can be set and V_{OUT} also can be set.

2 Transformer – continued

2.2 The Calculation of L_P , L_S

The transformer should be set L_P and L_S value that power supply works CCM operation. For that, L_P and L_S is determined to use “k” which is the indicator of CCM operation. k is expressed from Figure 39 I_{SPK} , I_{SB} by the following equation.

$$k = (I_{SPK} - I_{SB}) / I_{SPK}$$

where:

I_{SPK} is the Secondary transformer peak current

I_{SB} is the Secondary transformer bottom current

k is the Indicator of CCM ratio (It guides that it sets $k = 0.25$ when designing at first.)

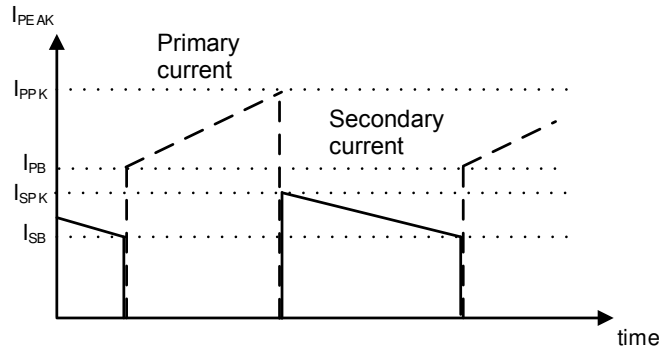

Figure 39. The Waveform Example of Primary and Secondary Current of Transformer

where:

I_{PPK} is the Primary transformer peak current

I_{PB} is the Primary transformer bottom current

I_{LIMIT} shown in electric characteristics determines maximum primary peak current. It enables to decide capable secondary minimum peak current from minimum I_{LIMIT} .

$$I_{SPK1(Min)} = I_{LIMIT(Min)} \times \frac{N_P}{N_S} \quad [A]$$

Next, $I_{SPK2(Max)}$ is calculated from secondary maximum output current ($I_{OUT(Max)}$).

$$I_{SPK2(Max)} = \frac{2 \times I_{OUT(Max)}}{(1 - D_{MAX}) \times (2 - k)} \times \frac{1}{\eta} \quad [A]$$

η is the Efficiency of power supply, it recommends to set to about 70 %

In order to output $I_{OUT(Max)}$, the condition of $I_{SPK2(Max)} < I_{SPK1(Min)}$ must be satisfied.

If not satisfied, re-design to change k value. The higher the k value, the wider the load area of DCM (Discontinuous Conduction Mode) operation. $k = 1$ means that the operation is DCM at all loads. IC has advantage of fast response and low EMI characteristics in CCM operation. For that, k is recommended lower value. Even if k value is high, there is no problem to output voltage regulation operation.

The secondary inductance $L_{S(Max)}$ is calculated by the following equation.

$$L_{S(Max)} = \frac{(2 - k) \times (V_{OUT} + V_F) \times (1 - D_{MAX})^2}{2 \times I_{OUT(Max)} \times f_{SW(Max)} \times k} \quad [\mu H]$$

where:

$f_{SW(Max)}$ is the Switching frequency ($f_{SW(Max)}$ is set to 430 kHz in IC)

$I_{OUT(Max)}$ is the Maximum secondary output current

Primary inductance L_P is calculated by below.

$$L_P = L_S \times \left(\frac{N_P}{N_S}\right)^2 \quad [\mu H]$$

2 Transformer – continued

2.3 The Calculation of I_{PRMS} and I_{SRMS}

Maximum primary RMS current (I_{PRMS}) and Maximum secondary RMS current (I_{SRMS}) are calculated below.

$$I_{PRMS} = \sqrt{\frac{(I_{PPK}^2 + I_{PPK} \times I_{PB} + I_{PB}^2) \times D_{MAX}}{3}} \quad [A]$$

$$I_{SRMS} = \sqrt{\frac{(I_{SPK}^2 + I_{SPK} \times I_{SB} + I_{SB}^2) \times (1 - D_{MAX})}{3}} \quad [A]$$

When selecting the wire diameter of transformer, refer to this RMS current.

3 Output Capacitor

The output capacitor place as close to the secondary diode as possible. Output capacitor value C_{OUT} is needed to set from the output ripple voltage (ΔV_O) and start-up time. The output ripple voltage which occurs by switching is calculated by below equation.

$$\Delta V_O = \frac{I_{OUT(Max)} \times D_{MAX}}{f_{SW(Max)} \times C_{OUT}} \quad [V]$$

On the other hand, when output capacitor is large, start-up time is long.

When SCP detection mask time ($t_{MASKSCP}$) in start-up is passed, if REF voltage is lower than V_{SCP} , power supply cannot output. Therefore, C_{OUT} must be satisfied below condition.

$$C_{OUT} \leq \frac{1}{2} \times \frac{t_{MASKSCP(Min)} \times \left\{ (I_{LIMIT(Min)} \times \frac{N_P}{N_S}) \times (1 - Duty) - I_{OUT(Max)} \right\}}{V_{OUT} \times \left(\frac{V_{SCP(Max)}}{V_{INTREF(Min)}} \right)} \quad [\mu F]$$

$$\text{Here, } \frac{V_{SCP(Max)}}{V_{INTREF(Min)}} = 0.762$$

A large output capacitance is required to hold the output voltage for load response or input voltage response. As a guide for output capacitor, it recommends the capacitance of 20 μF or more. And, ceramic capacitor may be lower capacitance because of temperature characteristics and variance, DC bias characteristics. It needs to select the parts to care them.

4 Input Capacitor

It uses ceramic capacitor to input capacitor and it is placed as close to the IC as possible. The capacitor value is set 10 μF or more.

Application Examples – continued

5 Secondary Output Diode

Because the forward voltage (V_F) of secondary output diode causes an error in the output voltage, it needs to use SBD or FRD which is low forward voltage (V_F). And, the peak of diode reverse voltage must not exceed the rating of the diode. The secondary RMS current must be set that it does not exceed the rating current. Generally, it is recommended that the reverse voltage of secondary output diode sets to have margin of 30 % or more.

$$V_R = (V_{IN(Max)} \times \frac{N_S}{N_P} + V_{OUT}) \times 1.3 + V_{SURGE} \quad [V]$$

where:

V_R is the reverse voltage of secondary output diode

$V_{IN(Max)}$ is VIN maximum pin voltage

N_P is the primary winding turns of transformer

N_S is the secondary winding turns of transformer

V_{OUT} is the Output voltage

V_{SURGE} is the Surge voltage of transformer generated to the diode

And it is recommended that rating current of output diode margin twice or more for I_{SRMS} .

6 Output Resistor and Output Zener Diode (Minimum Load Current)

The output voltage raises in no load or light load. This is the reason IC is always worked by the minimum switching frequency which is determined by maximum OFF time t_{OFF_MAX} and minimum ON time t_{ON_MIN} at light loads.

Because power supply supplies minimum power P_{O_MIN} by this minimum switching frequency, output voltage raises when secondary power is lighter than P_{O_MIN} . P_{O_MIN} is calculated by below.

$$P_{O_MIN} = \frac{V_{IN(Max)}^2}{2 \times L_P} \times t_{ON_MIN(Max)}^2 \times \frac{1}{t_{ON_MIN(Max)} + t_{OFF_MAX(Min)}} \quad [W]$$

$$I_{OUT_MIN} = \frac{P_{O_MIN}}{V_{OUT}} \quad \text{By the equation, } I_{OUT_MIN} \text{ can be also calculated.}$$

When the raise of secondary output voltage is unacceptable, it needs to connect zener diode to secondary output. It operates output voltage suppression less than zener diode voltage.

And it can prevent to rise output voltage by losses which is occurred to connect resistors to secondary output. The secondary load resistor R_{OUT} is less than below equation is needed. Secondary resistor loss is calculated by the equation.

$$P_{LOSS} = \frac{V_{OUT}^2}{R_{OUT}} \quad [W]$$

$$R_{OUT} \leq \frac{V_{OUT}^2}{P_{O_MIN}} = \frac{V_{OUT}^2}{\frac{V_{IN(Max)}^2}{2 \times L_P} \times t_{ON_MIN(Max)}^2 \times \frac{1}{t_{ON_MIN(Max)} + t_{OFF_MAX(Min)}}} \quad [\Omega]$$

In fact, even if R_{OUT} resistance which is calculated above equation is used, output voltage rises transiently in switching OFF time. For that, R_{OUT} should be set low enough. R_{OUT} needs to adjust through evaluation. R_{OUT} resistor is needed to notice power dissipation.

The reason of output voltage raise refers to Application Examples: "10.The Influence to Frequency and Output Voltage for Each Load".

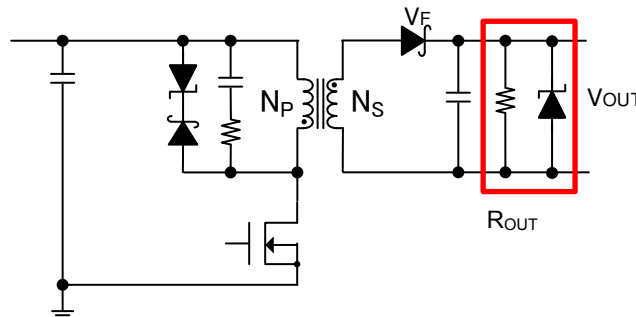

Figure 40. Zener Diode and Resistor to Secondary Output

Application Examples – continued

7 Snubber Circuit

When the combination degree of transformer is low or large current line of board is long, the large surge voltage may be occurred in the SW pin at turn OFF timing of MOSFET. Preventing it, the snubber circuit shown in figure 41 is used. This snubber circuit clamps fly-back voltage + surge voltage when the voltage exceeds snubber voltage.

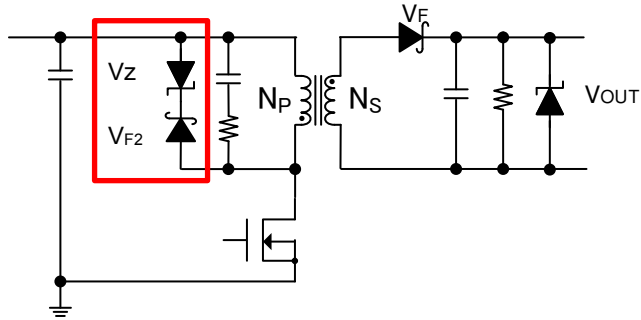

Figure 41. Snubber Circuit

The clamp voltage is determined the following equation.

$$V_{CLAMP} = V_{F2} + V_Z \quad [V]$$

where:

V_{CLAMP} is the Clamp setting voltage of snubber circuit

V_{F2} is the Forward voltage of SBD

V_Z is the Zener diode voltage

When the clamp setting voltage is lower than flyback voltage (equal to $\frac{N_P}{N_S} \times (V_{OUT} + V_F)$), large current flows to Zener diode in the turn off. Therefore, the snubber voltage (V_{CLAMP}) must be higher than flyback voltage. When snubber circuit is slow response, it may not clamp setting voltage. So, SW voltage must be evaluated.

8 Setting of SDX/EN Pin Resistor

8.1 Setting of Enable Voltage

It can set enable voltage V_{IN_ENABLE} by following equation after releasing VIN UVLO.

$$V_{IN_ENABLE} = V_{EN1} \times \frac{R_1 + (R_2 // R_{SDX/EN})}{R_2 // R_{SDX/EN}} \quad [V]$$

where:

V_{IN_ENABLE} is the Target VIN operating start voltage

V_{EN1} is the Enable voltage 1

$R_2 // R_{SDX/EN}$ is the Divided resistor between R_2 and $R_{SDX/EN}$ which is IC internal resistor

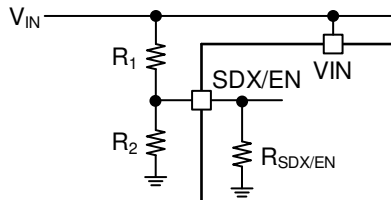

Figure 42. Resistors Connected to the SDX/EN Pin

8.2 Setting of Disable Voltage

It can set disable voltage $V_{IN_DISABLE}$ at VIN pin voltage falling by following equation.

$$V_{IN_DISABLE} = V_{EN2} \times \frac{R_1 + (R_2 // R_{SDX/EN})}{R_2 // R_{SDX/EN}} \quad [V]$$

where:

$V_{IN_DISABLE}$ is the Target VIN operating stop voltage

V_{EN2} is the Enable voltage2

Application Examples – continued

9 The Output Voltage Compensation Function by L_COMP Pin Resistor

This IC is built in output voltage compensation function which is prevented that output voltage decrease when primary transformer peak current (I_P) increase. The cause of the drop of output voltage V_{OUT} are the forward voltage change of secondary diode and transformer leakage etc.

The example of output voltage compensation is shown in Figure 43.

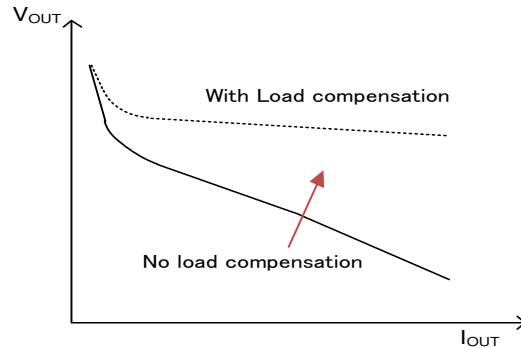

Figure 43. L_COMP Voltage Compensation Example

This function compensates the output voltage by increasing $I_{REFCOMP}$ current to the REF current that determines the output voltage.

$$V_{OUT} = R_{FB} \times \frac{N_S}{N_P} \times \left(\frac{V_{INTREF}}{R_{REF}} + I_{REFCOMP} \right) - V_F \quad [V]$$

REF current $\frac{V_{INTREF}}{R_{REF}}$ is fixed to 200 μA (Typ). $I_{REFCOMP}$ is increased for primary current increasing. As the result, output voltage is compensated by output current on the secondary side. $I_{REFCOMP}$ is calculated to below.

$$I_{REFCOMP} = R_{L_COMP} \times K_{L_COMP} \times I_{SW(Ave)} \quad [\mu A]$$

where:

R_{L_COMP} is the Resistor connected to the L_COMP pin

$I_{SW(Ave)}$ is the Averaging current flown to the SW pin

K_{L_COMP} is the Fixed value determined by IC

Averaging current $I_{SW(Ave)}$ of the SW pin can be converted below.

$$I_{SW(Ave)} = I_{S(Ave)} \times \frac{N_S}{N_P} = I_{OUT} \times \frac{1}{\eta} \times \frac{N_S}{N_P} \quad [A]$$

where:

η is the efficiency (It recommends 70 % in design. And adjust R_{L_COMP} in application evaluation.)

Because $I_{SW(Ave)}$ is proportional to I_{OUT} as shown in the above equation, it enables to compensate output voltage. The compensation degree can adjust by resistor value of the L_COMP pin.

Because I_{SW} is triangle wave current, connect the capacitor 0.1 μF or more at the L_COMP pin to flatten it.

The resistor value of the L_COMP pin is calculated by the following equation.

$$R_{L_COMP} = \frac{I_{REFCOMP}}{I_{SW(Ave)}} \times \frac{1}{K_{L_COMP}} \quad [k\Omega]$$

Be sure to evaluate the output voltage characteristics in the application and adjust L_COMP resistance as necessary. And, if the function is no use, the L_COMP pin is needed to connect to GND.

Application Examples – continued

10 The Influence to Frequency and Output Voltage for Each Load

This IC enables high efficiency to be lower switching frequency in light load. In CCM operation, the switching frequency is f_{SW} for a constant load. When the load is light, the operation is changed from CCM operation to DCM operation. Then, switching frequency is reduced from f_{SW} .

The output load $I_{OUT_f_{SW1}}$ is calculated below.

$$I_{OUT_f_{SW1}} = \frac{1}{2} \times \frac{(V_{IN} \times Duty)^2}{L_P \times f_{SW} \times V_{OUT}} \times \eta \quad [A]$$

where:

$I_{OUT_f_{SW1}}$ is the Switched output current from DCM to CCM

f_{SW} is the Switching frequency

V_{IN} is VIN pin voltage

L_P is the Primary inductance

V_{OUT} is the Output voltage

η is the Efficiency

As the load is further lightened, the ON time and OFF time decreases. ON time is operated by t_{ON_MIN} . The load current operated by t_{ON_MIN} is below.

$$I_{OUT_f_{SW2}} = \frac{1}{2} \times \frac{f_{SW} \times (V_{IN} \times t_{ON_MIN})^2}{L_P \times V_{OUT}} \times \eta \quad [A]$$

where:

$I_{OUT_f_{SW2}}$ is the Load current operated by minimum ON time

t_{ON_MIN} is the Minimum ON time

As the load is further lightened, the ON time is not shorter than the t_{ON_MIN} and the OFF time is longer. Because IC is determined maximum OFF time.

f_{SW_MIN} is calculated to below.

$$f_{SW_MIN} = \frac{1}{t_{ON_MIN} + t_{OFF_MAX}} \quad [kHz]$$

where:

f_{SW_MIN} is the Minimum switching frequency

t_{OFF_MAX} is the Maximum OFF time

Therefore, constant output power is generated by f_{SW_MIN} operation in no load or light load. For that, output voltage raises in no load or light load.

And the IC builds in frequency spectrum spread function for EMI improvement. For that, the switching frequency is changed within a constant rate. An output voltage ripple which is dependent on spectrum spread occurs by the function.

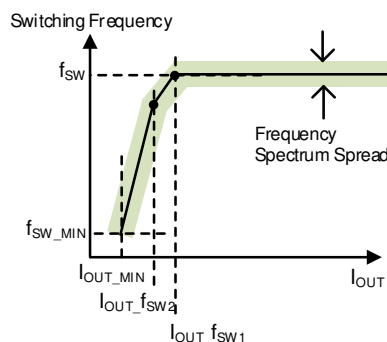
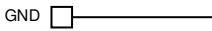
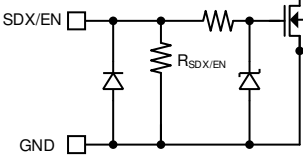
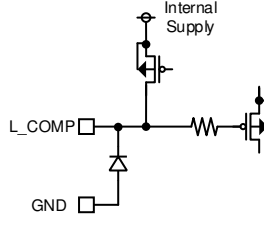
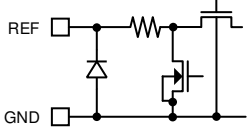
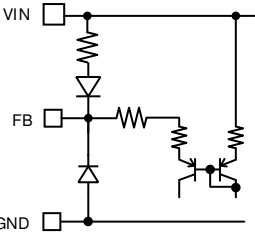
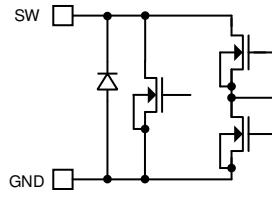
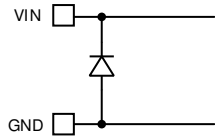

Figure 44. Switching Frequency

I/O Equivalence Circuits

1	GND	2	SDX/EN	3	L_COMP	4	REF
							
5	FB	6	N.C.	7	SW	8	VIN
							

Operational Notes

1. Reverse Connection of Power Supply

Connecting the power supply in reverse polarity can damage the IC. Take precautions against reverse polarity when connecting the power supply, such as mounting an external diode between the power supply and the IC's power supply pins.

2. Power Supply Lines

Design the PCB layout pattern to provide low impedance supply lines. Furthermore, connect a capacitor to ground at all power supply pins. Consider the effect of temperature and aging on the capacitance value when using electrolytic capacitors.

3. Ground Voltage

Ensure that no pins are at a voltage below that of the ground pin at any time, even during transient condition.

4. Ground Wiring Pattern

When using both small-signal and large-current ground traces, the two ground traces should be routed separately but connected to a single ground at the reference point of the application board to avoid fluctuations in the small-signal ground caused by large currents. Also ensure that the ground traces of external components do not cause variations on the ground voltage. The ground lines must be as short and thick as possible to reduce line impedance.

5. Recommended Operating Conditions

The function and operation of the IC are guaranteed within the range specified by the recommended operating conditions. The characteristic values are guaranteed only under the conditions of each item specified by the electrical characteristics.

6. Inrush Current

When power is first supplied to the IC, it is possible that the internal logic may be unstable and inrush current may flow instantaneously due to the internal powering sequence and delays, especially if the IC has more than one power supply. Therefore, give special consideration to power coupling capacitance, power wiring, width of ground wiring, and routing of connections.

7. Testing on Application Boards

When testing the IC on an application board, connecting a capacitor directly to a low-impedance output pin may subject the IC to stress. Always discharge capacitors completely after each process or step. The IC's power supply should always be turned off completely before connecting or removing it from the test setup during the inspection process. To prevent damage from static discharge, ground the IC during assembly and use similar precautions during transport and storage.

8. Inter-pin Short and Mounting Errors

Ensure that the direction and position are correct when mounting the IC on the PCB. Incorrect mounting may result in damaging the IC. Avoid nearby pins being shorted to each other especially to ground, power supply and output pin. Inter-pin shorts could be due to many reasons such as metal particles, water droplets (in very humid environment) and unintentional solder bridge deposited in between pins during assembly to name a few.

9. Unused Input Pins

Input pins of an IC are often connected to the gate of a MOS transistor. The gate has extremely high impedance and extremely low capacitance. If left unconnected, the electric field from the outside can easily charge it. The small charge acquired in this way is enough to produce a significant effect on the conduction through the transistor and cause unexpected operation of the IC. So unless otherwise specified, unused input pins should be connected to the power supply or ground line.

Operational Notes – continued

10. Regarding the Input Pin of the IC

This monolithic IC contains P+ isolation and P substrate layers between adjacent elements in order to keep them isolated. P-N junctions are formed at the intersection of the P layers with the N layers of other elements, creating a parasitic diode or transistor. For example (refer to figure below):

When $GND > Pin A$ and $GND > Pin B$, the P-N junction operates as a parasitic diode.

When $GND > Pin B$, the P-N junction operates as a parasitic transistor.

Parasitic diodes inevitably occur in the structure of the IC. The operation of parasitic diodes can result in mutual interference among circuits, operational faults, or physical damage. Therefore, conditions that cause these diodes to operate, such as applying a voltage lower than the GND voltage to an input pin (and thus to the P substrate) should be avoided.

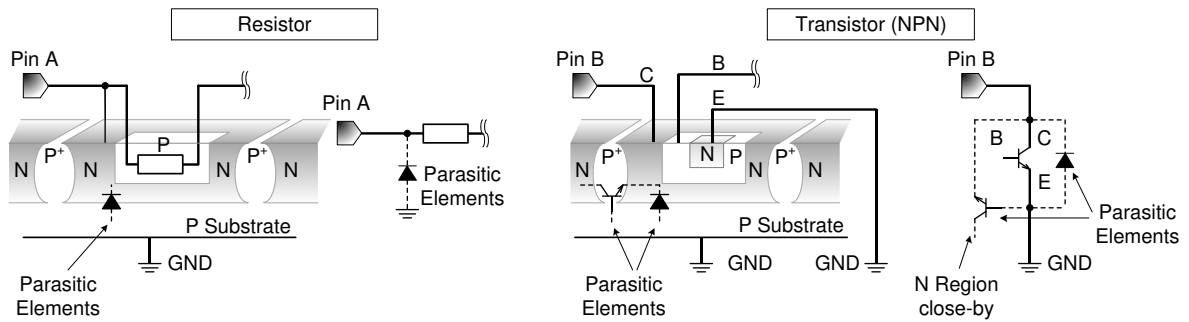

Figure 45. Example of Monolithic IC Structure

11. Ceramic Capacitor

When using a ceramic capacitor, determine a capacitance value considering the change of capacitance with temperature and the decrease in nominal capacitance due to DC bias and others.

12. Thermal Shutdown Circuit (TSD)

This IC has a built-in thermal shutdown circuit that prevents heat damage to the IC. Normal operation should always be within the IC's maximum junction temperature rating. If however the rating is exceeded for a continued period, the junction temperature (T_j) will rise which will activate the TSD circuit that will turn OFF power output pins. When the T_j falls below the TSD threshold, the circuits are automatically restored to normal operation.

Note that the TSD circuit operates in a situation that exceeds the absolute maximum ratings and therefore, under no circumstances, should the TSD circuit be used in a set design or for any purpose other than protecting the IC from heat damage.

13. Over Current Protection Circuit (OCP)

This IC incorporates an integrated overcurrent protection circuit that is activated when the load is shorted. This protection circuit is effective in preventing damage due to sudden and unexpected incidents. However, the IC should not be used in applications characterized by continuous operation or transitioning of the protection circuit.

Ordering Information



Marking Diagram

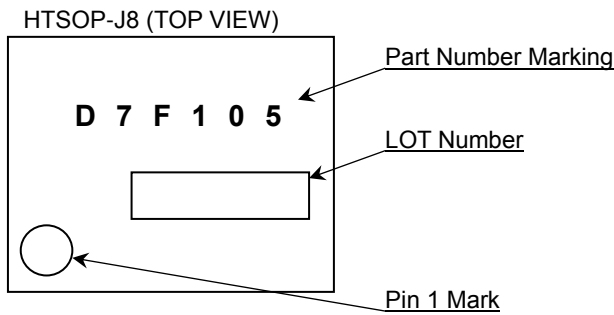

Physical Dimension and Packing Information

Package Name	HTSOP-J8
--------------	----------

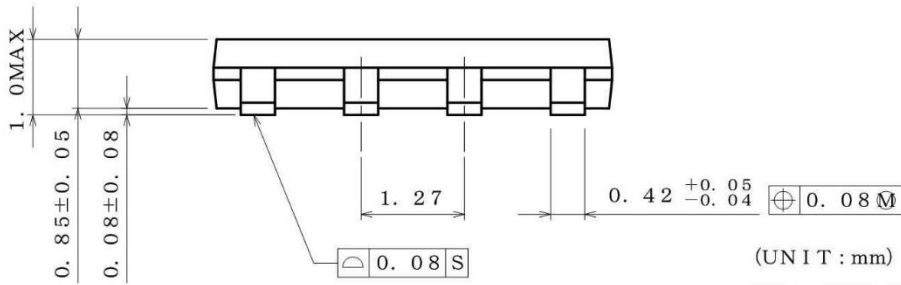
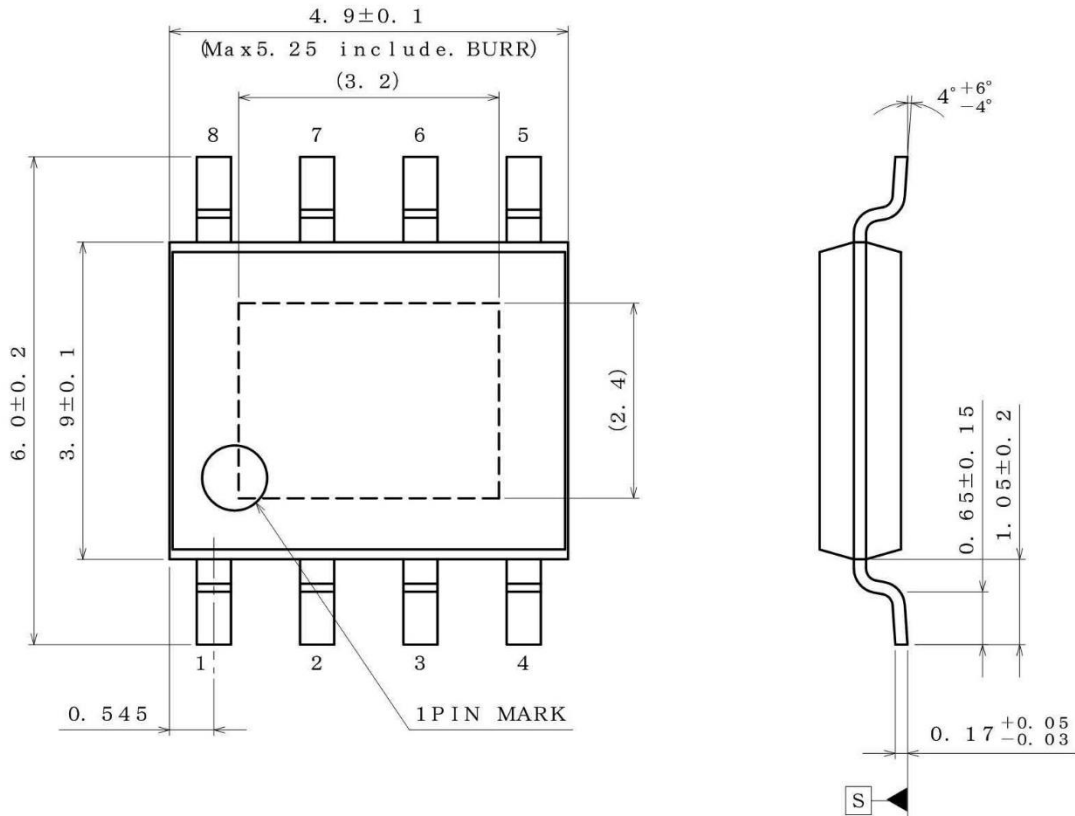

(UNIT : mm)

PKG : HTSOP-J8

Drawing No. EX169-5002-2

< Tape and Reel Information >

Tape	Embossed carrier tape
Quantity	2500pcs
Direction of feed	E2 The direction is the pin 1 of product is at the upper left when you hold reel on the left hand and you pull out the tape on the right hand

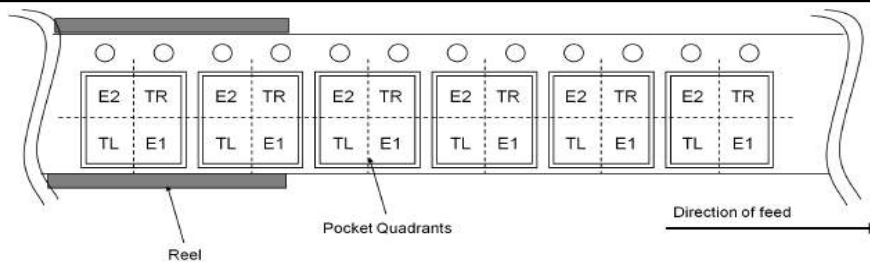

Revision History

Date	Revision	Changes
01.Mar.2022	001	New Release

Notice

Precaution on using ROHM Products

1. If you intend to use our Products in devices requiring extremely high reliability (such as medical equipment ^(Note 1), aircraft/spacecraft, nuclear power controllers, etc.) and whose malfunction or failure may cause loss of human life, bodily injury or serious damage to property ("Specific Applications"), please consult with the ROHM sales representative in advance. Unless otherwise agreed in writing by ROHM in advance, ROHM shall not be in any way responsible or liable for any damages, expenses or losses incurred by you or third parties arising from the use of any ROHM's Products for Specific Applications.

(Note1) Medical Equipment Classification of the Specific Applications

JAPAN	USA	EU	CHINA
CLASS III	CLASS III	CLASS II b	CLASS III
CLASS IV		CLASS III	

2. ROHM designs and manufactures its Products subject to strict quality control system. However, semiconductor products can fail or malfunction at a certain rate. Please be sure to implement, at your own responsibilities, adequate safety measures including but not limited to fail-safe design against the physical injury, damage to any property, which a failure or malfunction of our Products may cause. The following are examples of safety measures:
 - [a] Installation of protection circuits or other protective devices to improve system safety
 - [b] Installation of redundant circuits to reduce the impact of single or multiple circuit failure
3. Our Products are not designed under any special or extraordinary environments or conditions, as exemplified below. Accordingly, ROHM shall not be in any way responsible or liable for any damages, expenses or losses arising from the use of any ROHM's Products under any special or extraordinary environments or conditions. If you intend to use our Products under any special or extraordinary environments or conditions (as exemplified below), your independent verification and confirmation of product performance, reliability, etc. prior to use, must be necessary:
 - [a] Use of our Products in any types of liquid, including water, oils, chemicals, and organic solvents
 - [b] Use of our Products outdoors or in places where the Products are exposed to direct sunlight or dust
 - [c] Use of our Products in places where the Products are exposed to sea wind or corrosive gases, including Cl₂, H₂S, NH₃, SO₂, and NO₂
 - [d] Use of our Products in places where the Products are exposed to static electricity or electromagnetic waves
 - [e] Use of our Products in proximity to heat-producing components, plastic cords, or other flammable items
 - [f] Sealing or coating our Products with resin or other coating materials
 - [g] Use of our Products without cleaning residue of flux (Exclude cases where no-clean type fluxes is used. However, recommend sufficiently about the residue.); or Washing our Products by using water or water-soluble cleaning agents for cleaning residue after soldering
 - [h] Use of the Products in places subject to dew condensation
4. The Products are not subject to radiation-proof design.
5. Please verify and confirm characteristics of the final or mounted products in using the Products.
6. In particular, if a transient load (a large amount of load applied in a short period of time, such as pulse, is applied, confirmation of performance characteristics after on-board mounting is strongly recommended. Avoid applying power exceeding normal rated power; exceeding the power rating under steady-state loading condition may negatively affect product performance and reliability.
7. De-rate Power Dissipation depending on ambient temperature. When used in sealed area, confirm that it is the use in the range that does not exceed the maximum junction temperature.
8. Confirm that operation temperature is within the specified range described in the product specification.
9. ROHM shall not be in any way responsible or liable for failure induced under deviant condition from what is defined in this document.

Precaution for Mounting / Circuit board design

1. When a highly active halogenous (chlorine, bromine, etc.) flux is used, the residue of flux may negatively affect product performance and reliability.
2. In principle, the reflow soldering method must be used on a surface-mount products, the flow soldering method must be used on a through hole mount products. If the flow soldering method is preferred on a surface-mount products, please consult with the ROHM representative in advance.

For details, please refer to ROHM Mounting specification

Precautions Regarding Application Examples and External Circuits

1. If change is made to the constant of an external circuit, please allow a sufficient margin considering variations of the characteristics of the Products and external components, including transient characteristics, as well as static characteristics.
2. You agree that application notes, reference designs, and associated data and information contained in this document are presented only as guidance for Products use. Therefore, in case you use such information, you are solely responsible for it and you must exercise your own independent verification and judgment in the use of such information contained in this document. ROHM shall not be in any way responsible or liable for any damages, expenses or losses incurred by you or third parties arising from the use of such information.

Precaution for Electrostatic

This Product is electrostatic sensitive product, which may be damaged due to electrostatic discharge. Please take proper caution in your manufacturing process and storage so that voltage exceeding the Products maximum rating will not be applied to Products. Please take special care under dry condition (e.g. Grounding of human body / equipment / solder iron, isolation from charged objects, setting of Ionizer, friction prevention and temperature / humidity control).

Precaution for Storage / Transportation

1. Product performance and soldered connections may deteriorate if the Products are stored in the places where:
 - [a] the Products are exposed to sea winds or corrosive gases, including Cl₂, H₂S, NH₃, SO₂, and NO₂
 - [b] the temperature or humidity exceeds those recommended by ROHM
 - [c] the Products are exposed to direct sunshine or condensation
 - [d] the Products are exposed to high Electrostatic
2. Even under ROHM recommended storage condition, solderability of products out of recommended storage time period may be degraded. It is strongly recommended to confirm solderability before using Products of which storage time is exceeding the recommended storage time period.
3. Store / transport cartons in the correct direction, which is indicated on a carton with a symbol. Otherwise bent leads may occur due to excessive stress applied when dropping of a carton.
4. Use Products within the specified time after opening a humidity barrier bag. Baking is required before using Products of which storage time is exceeding the recommended storage time period.

Precaution for Product Label

A two-dimensional barcode printed on ROHM Products label is for ROHM's internal use only.

Precaution for Disposition

When disposing Products please dispose them properly using an authorized industry waste company.

Precaution for Foreign Exchange and Foreign Trade act

Since concerned goods might be fallen under listed items of export control prescribed by Foreign exchange and Foreign trade act, please consult with ROHM in case of export.

Precaution Regarding Intellectual Property Rights

1. All information and data including but not limited to application example contained in this document is for reference only. ROHM does not warrant that foregoing information or data will not infringe any intellectual property rights or any other rights of any third party regarding such information or data.
2. ROHM shall not have any obligations where the claims, actions or demands arising from the combination of the Products with other articles such as components, circuits, systems or external equipment (including software).
3. No license, expressly or implied, is granted hereby under any intellectual property rights or other rights of ROHM or any third parties with respect to the Products or the information contained in this document. Provided, however, that ROHM will not assert its intellectual property rights or other rights against you or your customers to the extent necessary to manufacture or sell products containing the Products, subject to the terms and conditions herein.

Other Precaution

1. This document may not be reprinted or reproduced, in whole or in part, without prior written consent of ROHM.
2. The Products may not be disassembled, converted, modified, reproduced or otherwise changed without prior written consent of ROHM.
3. In no event shall you use in any way whatsoever the Products and the related technical information contained in the Products or this document for any military purposes, including but not limited to, the development of mass-destruction weapons.
4. The proper names of companies or products described in this document are trademarks or registered trademarks of ROHM, its affiliated companies or third parties.

General Precaution

1. Before you use our Products, you are requested to carefully read this document and fully understand its contents. ROHM shall not be in any way responsible or liable for failure, malfunction or accident arising from the use of any ROHM's Products against warning, caution or note contained in this document.
2. All information contained in this document is current as of the issuing date and subject to change without any prior notice. Before purchasing or using ROHM's Products, please confirm the latest information with a ROHM sales representative.
3. The information contained in this document is provided on an "as is" basis and ROHM does not warrant that all information contained in this document is accurate and/or error-free. ROHM shall not be in any way responsible or liable for any damages, expenses or losses incurred by you or third parties resulting from inaccuracy or errors of or concerning such information.