

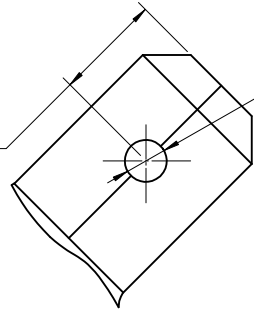

MATERIAL NUMBER	ENGINEERING NUMBER	PLATING 
190430010	VWA-0	NONE
190430027	VWA-0-1	ELECTRO-TIN
190430028	VWA-0-HT	ELECTRO-NICKEL

 $\frac{.186}{4.72}$ MAX TYP.2



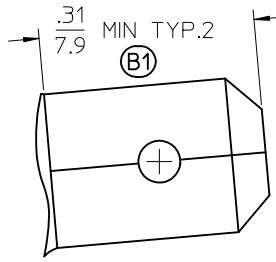
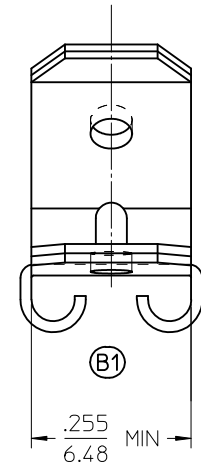
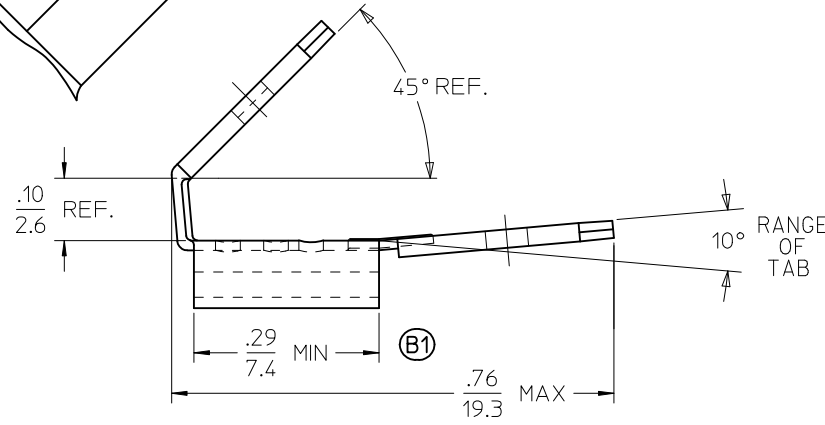

 $\phi .063$ MIN
1.60 TYP.2



SALES DRAWING

NOTE:

1. MATERIAL: BRASS, .015 THICK REF.
-  2. PLATING SEE CHART.

RLS IN ME10, MOD TOLRNCS EC NO: WNA2011-0262 DRW:ETHRODAHL 2009/07/28 CHKD:JMACNEIL 2010/11/16 APPR:JMACNEIL 2010/12/06	QUALITY SYMBOLS	GENERAL TOLERANCES (UNLESS SPECIFIED)		DIMENSION STYLE	SCALE	DESIGN UNITS	THIRD ANGLE PROJECTION		
	 = 0	mm	INCH	IN/MM	5:1	INCH			
	 = 0	4 PLACES ± --- ± ---	3 PLACES ± --- ± .005	DRAWN BY	DATE	TITLE			
		2 PLACES ± 0.13 ± .01	1 PLACE ± 0.25 ± ---	CHECKED BY	DATE	3 WAY CONNECTOR 2 MALE TABS, 1 FEMALE .250X.032 QUICK DISCONN			
		ANGULAR ± 20°		APPROVED BY	DATE				
	REV	DESCRIPTION	DRAFT WHERE APPLICABLE MUST REMAIN WITHIN DIMENSIONS		MATERIAL NO.	DOCUMENT NO.	SHEET NO.		
B1				SEE CHART	SD-19043-003	1 OF 1			