

10 9 8 7 6 5 4 3 2 1

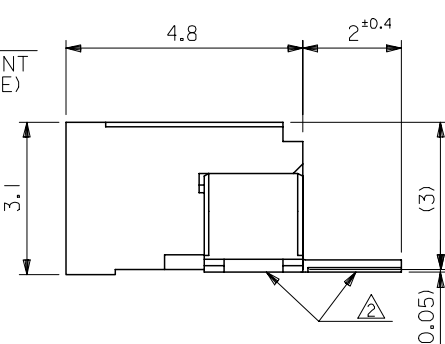
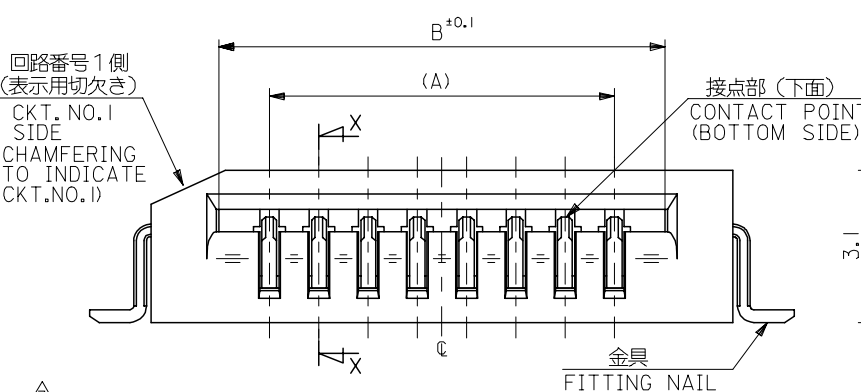
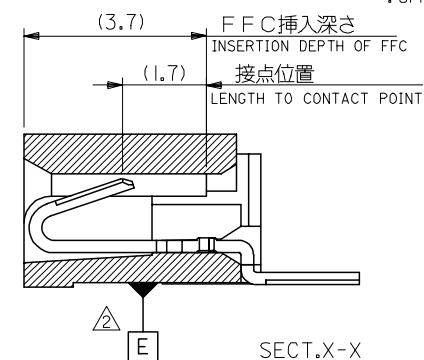
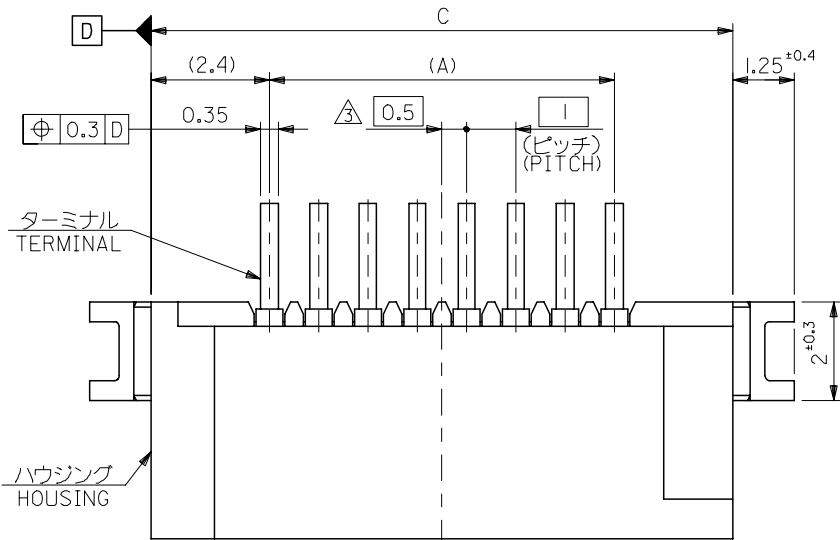

注記 NOTES:

1. 使用材料 MATERIAL  
 ハウジング: PPS,UL94V-0  
 ターミナル: リン青銅 (τ=0.25)  
 メッキ: ニッケル下地鍍ビスマスメッキ  
 金具: リン青銅 (τ=0.25)  
 メッキ: ニッケル下地鍍メッキ

HOUSING : PPS,UL94V-0  
 TERMINAL : PHOSPHOR BRONZE  
 PLATING : TIN-BISMUTH OVER NICKEL  
 FITTING NAIL : PHOSPHOR BRONZE  
 PLATING : TIN OVER NICKEL

△ 基準面 E からのソルダーテールとフィッティングネイルの半田付け面のズレ量は、  
 上方向に0.1MAX、下方向0.15MAXとする。  
 MISALIGNMENT OF SOLDER TAIL AND FITTING NAIL FROM E  
 : UPPER DIRECTION 0.1 MAX., LOWER DIRECTION 0.15 MAX.

33.8	31.05	29	52852-3019	30
32.8	30.05	28	-2919	29
31.8	29.05	27	-2819	28
30.8	28.05	26	-2719	27
29.8	27.05	25	-2619	26
28.8	26.05	24	-2519	25
27.8	25.05	23	-2419	24
26.8	24.05	22	-2319	23
25.8	23.05	21	-2219	22
24.8	22.05	20	-2119	21
23.8	21.05	19	-2019	20
22.8	20.05	18	-1919	19
21.8	19.05	17	-1819	18
20.8	18.05	16	-1719	17
19.8	17.05	15	-1619	16
18.8	16.05	14	-1519	15
17.8	15.05	13	-1419	14
16.8	14.05	12	-1319	13
15.8	13.05	11	-1219	12
14.8	12.05	10	-1119	11
13.8	11.05	9	-1019	10
12.8	10.05	8	-0919	9
11.8	9.05	7	-0819	8
10.8	8.05	6	-0719	7
9.8	7.05	5	-0619	6
8.8	6.05	4	-0519	5
7.8	5.05	3	52852-0419	4
C	B	A	MATERIAL NO.	極数 CIRCUIT

△ 偶数極に適用。  
 APPLY FOR EVEN CKT.  
 4. 本製品は 52852-\*\*\*10 の鉛フリー品である。  
 THIS PRODUCT IS LEAD FREE OF 52852-\*\*\*10

REVISED EC NO: J2005-1451 DRAWN: NAIDA 2004/11/16 CHKD: KTOJO 2004/11/17 APPR: NUKITA 2004/11/26	GENERAL TOLERANCES (UNLESS SPECIFIED)		DIMENSION STYLE MM ONLY		SCALE ---	DESIGN UNITS METRIC	MODEL NO. 52852-***19
	10 UNDER	±0.2	DRAWN BY M. NAGATA	DATE '04/02/27	TITLE 1.0 FFC CONN NON ZIF SMT RA (BOTTOM CONTACT) -LEAD FREE-		
	10 OVER 30 UNDER	±0.25	CHECKED BY K. TOJO	DATE '04/02/27	MOLEX INCORPORATED		
	30 OVER	±0.3	APPROVED BY M. SASAO	DATE '04/02/27	DOCUMENT NO. SD-52852-010	SHEET NO. 1 OF 2	
A	ANGULAR	±3 °	MATERIAL NO. SEE CAHRT		THIS DRAWING CONTAINS INFORMATION THAT IS PROPRIETARY TO MOLEX INCORPORATED AND SHOULD NOT BE USED WITHOUT WRITTEN PERMISSION		
DRAFT WHERE APPLICABLE MUST REMAIN WITHIN DIMENSIONS							

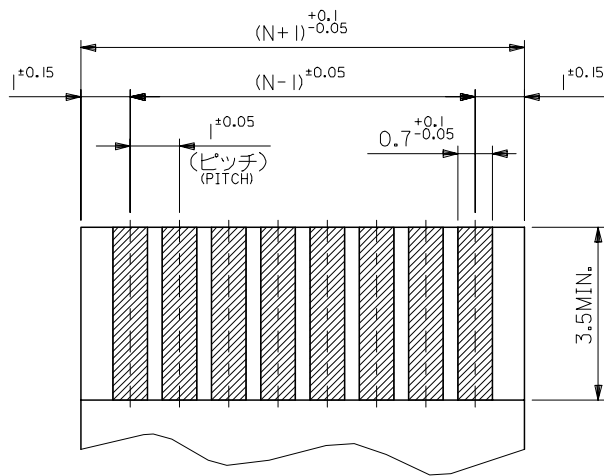

(仕上がり厚さ)  $0.3 \pm 0.03$   
 THICKNESS  
 適合 FPC/FFC 推奨寸法  
 APPLICABLE FPC/FFC  
 RECOMMENDED DIMENSION.

FPC/FFCについて:

打抜き方向は導体側から補強板側を推奨いたします。

ABOUT FPC/FFC

RECOMMENDED PUNCHER DIRECTION : FROM CONDUCTOR SIDE TO STIFFENER FILM SIDE.

FPCについて:

補強フィルム材質はポリイミドを推奨します。

接着剤は熱硬化接着剤を推奨します。

ABOUT FPC

RECOMMENDED MATERIAL :  
 STIFFENER FILM : POLYIMIDE  
 BONDING AGENT : THERMOSETTING BONDING AGENT

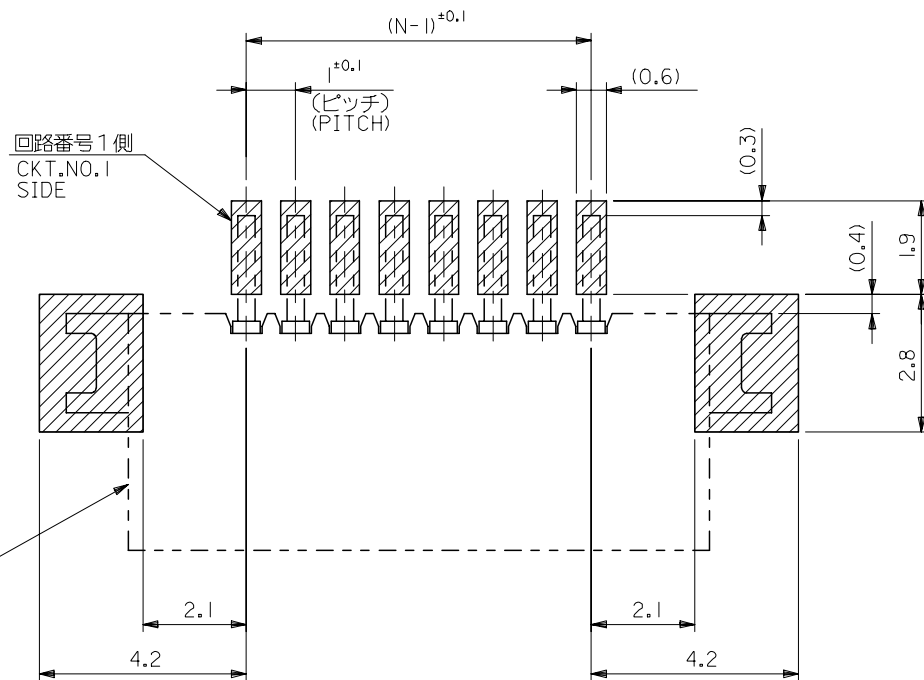

コネクタ位置  
 CONNECTOR  
 POSITION

参考基板レイアウト (マウント面)

RECOMMENDED P.C.BOARD  
 PATTERN DIMENSION. (REF.)  
 (MOUNTING AREA)

MODEL NO. 52852-\*\*\*19

REVISED EC NO: J2005-1451 DRAWN:NAIDA 2004/11/16 CHKD:KTOJO 2004/11/17 APPR:NUKITA 2004/11/26	GENERAL TOLERANCES (UNLESS SPECIFIED)		DIMENSION STYLE MM ONLY		SCALE ---	DESIGN UNITS METRIC	THIRD ANGLE PROJECTION
	10 UNDER	±0.2	DRAWN BY M. NAGATA	DATE '04/02/27	TITLE 1.0 FFC CONN NON ZIF SMT RA (BOTTOM CONTACT) -LEAD FREE-		
	10 OVER 30 UNDER	±0.25	CHECKED BY K. TOJO	DATE '04/02/27			
	30 OVER	±0.3	APPROVED BY M. SASAO	DATE '04/02/27	MOLEX INCORPORATED		
ANGULAR	±3 °	MATERIAL NO.	DOCUMENT NO. SD-52852-010	SHEET NO. 2 OF 2			
A	DRAFT WHERE APPLICABLE MUST REMAIN WITHIN DIMENSIONS		SEE CHART		THIS DRAWING CONTAINS INFORMATION THAT IS PROPRIETARY TO MOLEX INCORPORATED AND SHOULD NOT BE USED WITHOUT WRITTEN PERMISSION		

NOTES

- 製品詳細寸法は製品単体図面を参照して下さい。  
FOR DETAIL OF CONNECTOR DIMENSIONS, PLEASE SEE THE DRAWING OF CONNECTOR ITSELF (NOT PACKAGED).
- 梱包数量：1000個/リール  
NUMBER OF CONNECTORS : 1000PCS/REEL
- リードテープ長さ LEAD TAPE LENGTH

引き出し方向  
PULL OUT DIRECTION

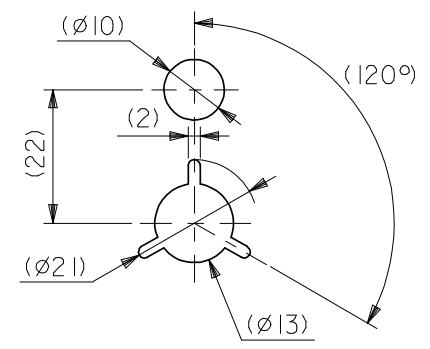
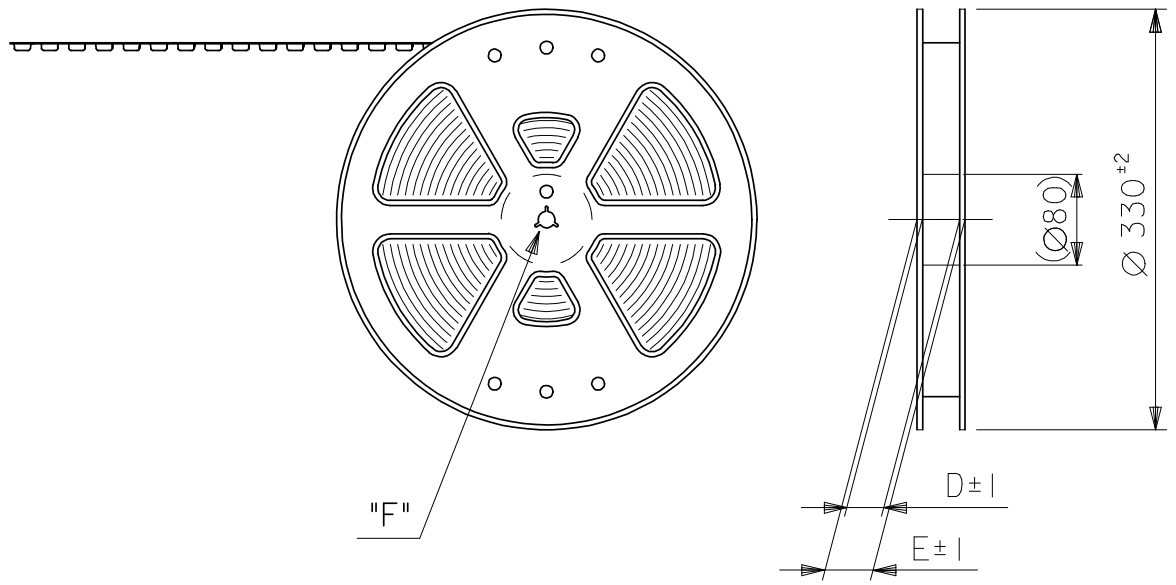

DETAIL "F"

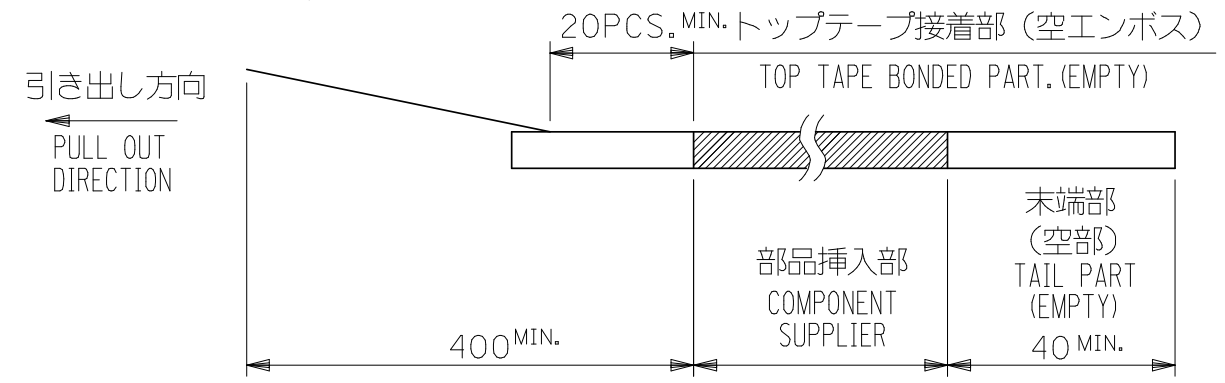

- トップテープの剥離強度：0.1～1.3N(10～130gf)  
(剥離方向は下図参照)  
尚、本規格値は出荷時に適用。(但し、輸送時に剥離が発生しないこと。)  
PEELING OFF FORCE OF TOP TAPE : 0.1～1.3N(10～130gf)  
(PEELING DIRECTION AS SHOWN IN FOLLOWING FIG.)  
THIS REQUIREMENT SHOULD BE APPLIED AT SHIPMENT.  
PEEL OFF SHOULD NOT BE ALLOWED , DURING TRANSPORTATION.

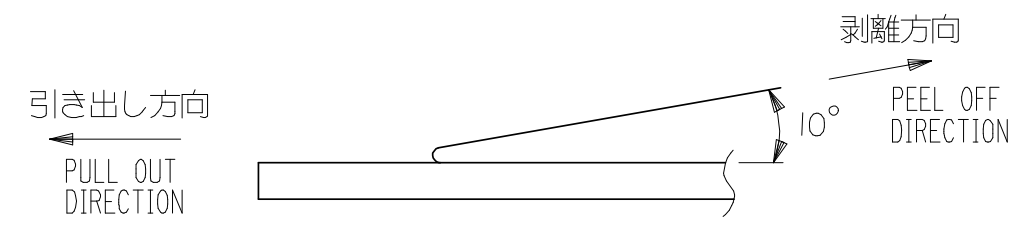

- 材料(MATERIAL)  
キャリアテープ(CARRIER TAPE)：ポリプロピレン(POLYPROPYLENE)  
トップテープ(TOPTAPE)：PET , PE , PEF  
リール(REEL)：ポリスチレン (P S) <リサイクル材を含む>  
POLYSTYREN(PS) <RECYCLE MATERIAL CONTAINED>

- 本製品は 52852-\*\*\*90 の鉛フリー品である。  
THIS PRODUCT IS LEAD FREE OF 52852-\*\*\*90

MODEL NO. 52852-\*\*\*70

REVISED EC NO: J2008-1818 DRWN: MNABEI 2007/11/12 CHKD: MISOGAYA 2007/11/13 APPR: NUKITA 2007/11/26	DESCRIPTION GENERAL TOLERANCES (UNLESS SPECIFIED)	10 UNDER ±0.2	DIMENSION STYLE MM ONLY	SCALE ---	DESIGN UNITS METRIC	THIRD ANGLE PROJECTION	
		10 OVER 30 UNDER ±0.25	DRAWN BY DATE M. NAGATA '04/02/27	TITLE 1.0 FPC CONN NON ZIF SMT RA BOTTOM CONTACT EMBSTP -LEAD FREE-			
		30 OVER ±0.3	CHECKED BY DATE K. TOJO '04/02/27	MOLEX INCORPORATED			
		ANGULAR ±3 °	APPROVED BY DATE M. SASAO '04/02/27	MATERIAL NO. SEE TABLE	DOCUMENT NO. SD-52852-011		SHEET NO. 1 OF 5
		DRAFT WHERE APPLICABLE MUST REMAIN WITHIN DIMENSIONS	SIZE A3	THIS DRAWING CONTAINS INFORMATION THAT IS PROPRIETARY TO MOLEX INCORPORATED AND SHOULD NOT BE USED WITHOUT WRITTEN PERMISSION			

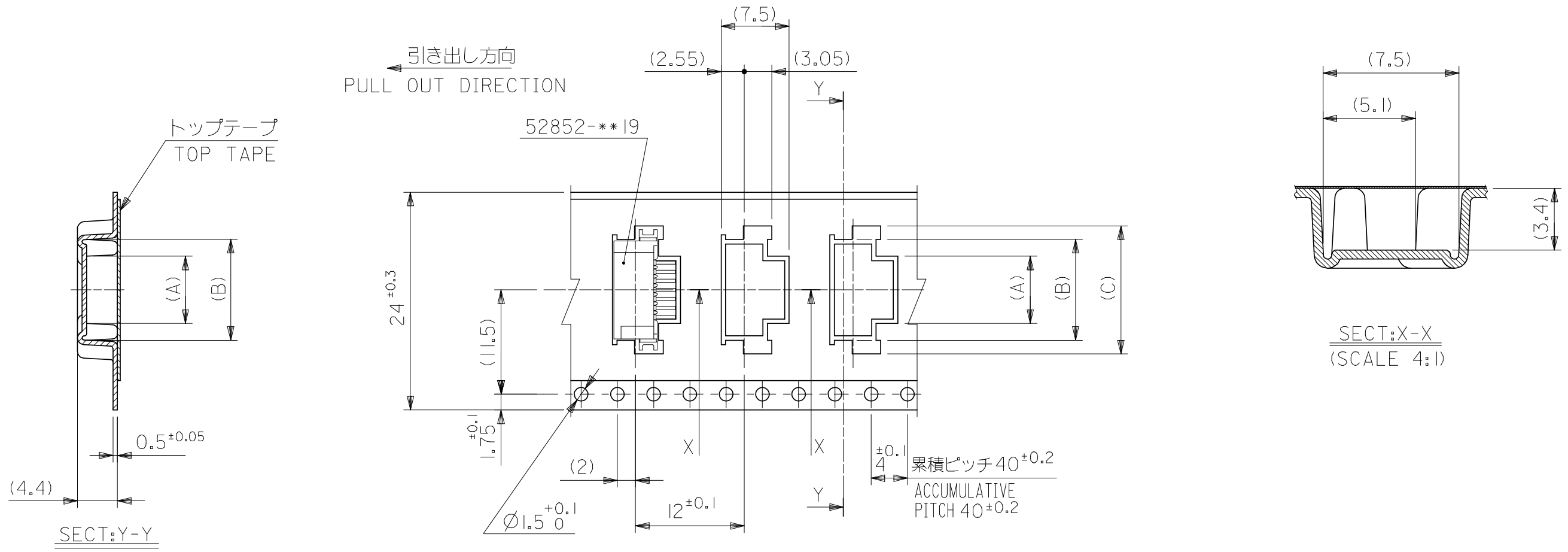

24mm幅キャリアテープ  
24mm WIDTH CARRIER TAPE

24	29.4	25.4	18.1	15.1	11.4	52852-1170	11
			17.1	14.1	10.4	52852-1070	10
			16.1	13.1	9.4	52852-0970	9
			15.1	12.1	8.4	52852-0870	8
			14.1	11.1	7.4	52852-0770	7
			13.1	10.1	6.4	52852-0670	6
			12.1	9.1	5.4	52852-0570	5
			11.1	8.1	4.4	52852-0470	4
キャリアテープ幅 CARRIER TAPE WIDTH	E	D	(C)	(B)	(A)	MATERIAL NO.	極数 CKT.

REVISED EC NO: J2008-1818 DRWN: MNABEI 2007/11/12 CHKD: M. ISOGAYA 2007/11/13 APPR: NUKITA 2007/11/26	DESCRIPTION 10 UNDER ±0.2 10 OVER 30 UNDER ±0.25 30 OVER ±0.3 ANGULAR ±3 ° DRAFT WHERE APPLICABLE MUST REMAIN WITHIN DIMENSIONS	GENERAL TOLERANCES (UNLESS SPECIFIED)		DIMENSION STYLE MM ONLY		SCALE ---	DESIGN UNITS METRIC	MODEL NO. 52852-***70	THIRD ANGLE PROJECTION	
		DRAWN BY M. NAGATA		DATE '04/02/27		TITLE 1.0 FPC CONN NON ZIF SMT RA BOTTOM CONTACT EMBSTP -LEAD FREE-				
		CHECKED BY K. TOJO		DATE '04/02/27		MOLEX INCORPORATED				
		APPROVED BY M. SASAO		DATE '04/02/27		MATERIAL NO. SEE TABLE		DOCUMENT NO. SD-52852-011		SHEET NO. 2 OF 5
		SIZE A3		THIS DRAWING CONTAINS INFORMATION THAT IS PROPRIETARY TO MOLEX INCORPORATED AND SHOULD NOT BE USED WITHOUT WRITTEN PERMISSION						

引き出し方向  
PULL OUT DIRECTION

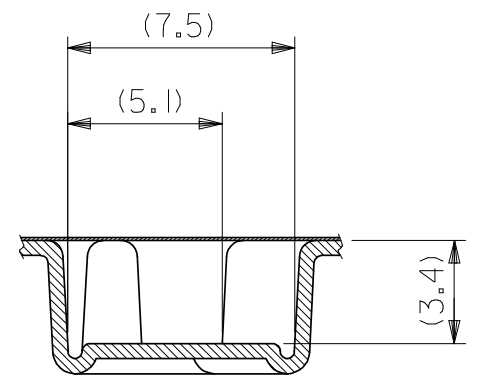
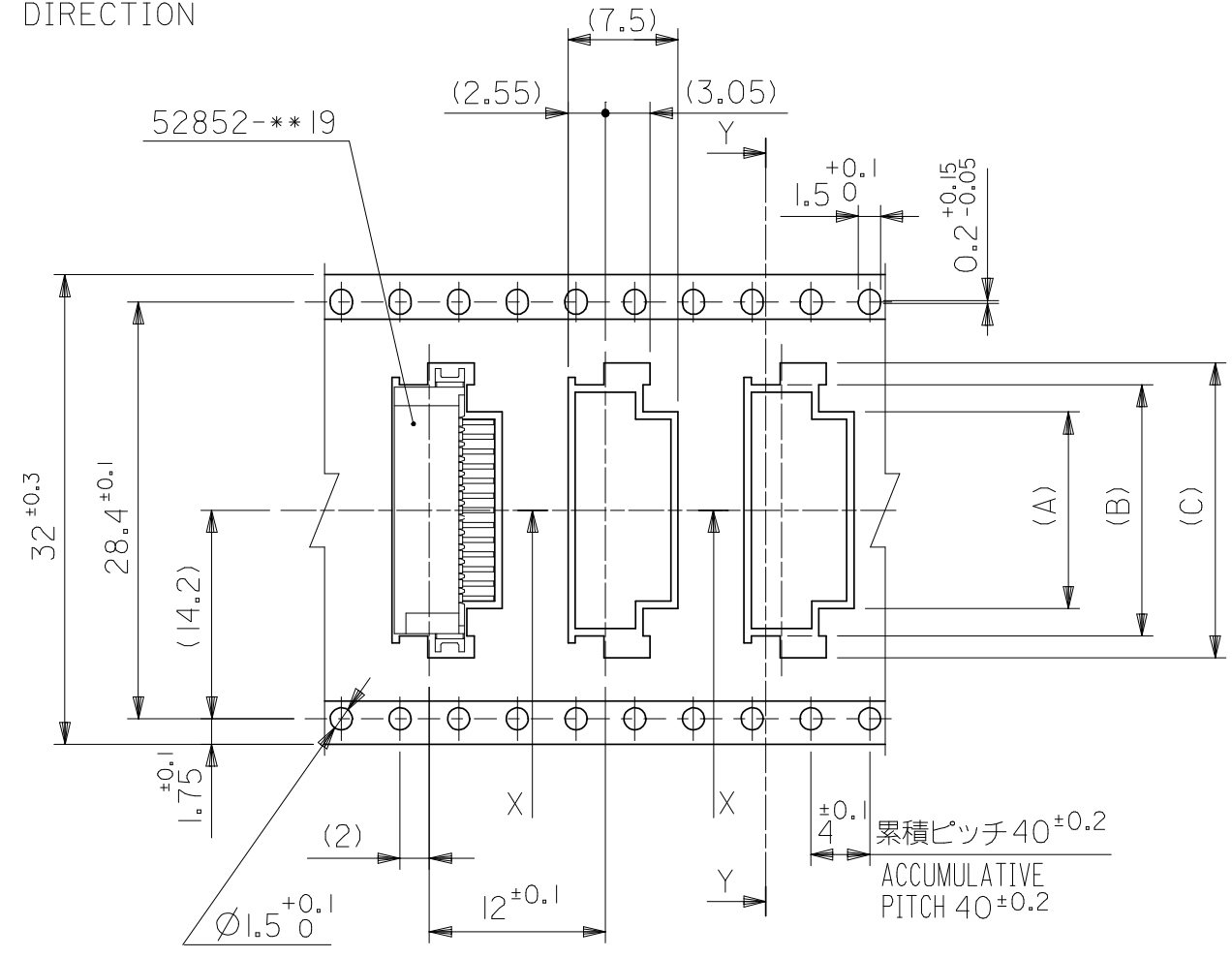
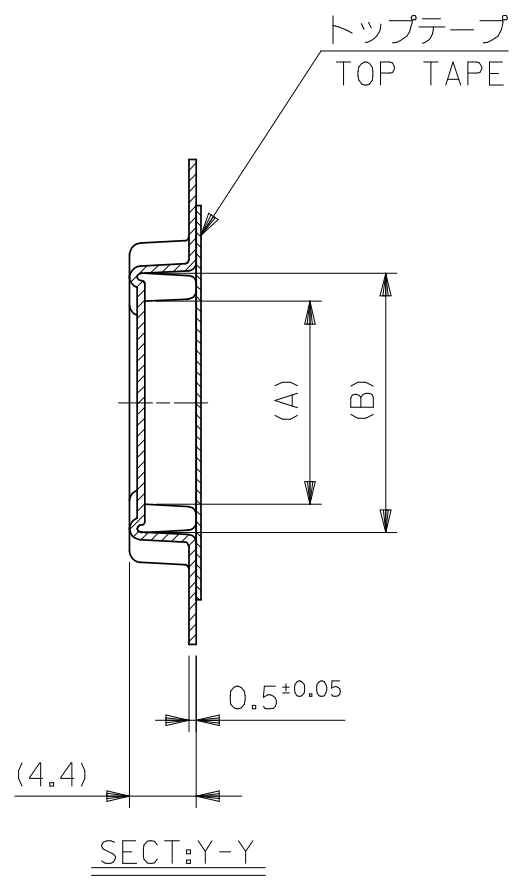

32mm幅キャリアテープ  
32mm WIDTH CARRIER TAPE

32	37.5	33.5	23.1	20.1	16.4	52852-1670	16
			22.1	19.1	15.4	52852-1570	15
			21.1	18.1	14.4	52852-1470	14
			20.1	17.1	13.4	52852-1370	13
			19.1	16.1	12.4	52852-1270	12
キャリアテープ幅 CARRIER TAPE WIDTH	E	D	(C)	(B)	(A)	MATERIAL NO.	極数 CKT.

REVISED EC NO: J2008-1818 DRWN: MNABEI 2007/11/12 CHKD: M. ISOGAYA 2007/11/13 APPR: NUKITA 2007/11/26	DESCRIPTION 10 UNDER ± 0.2 10 OVER 30 UNDER ± 0.25 30 OVER ± 0.3 ANGULAR ± 3 ° DRAFT WHERE APPLICABLE MUST REMAIN WITHIN DIMENSIONS	GENERAL TOLERANCES (UNLESS SPECIFIED)	DIMENSION STYLE MM ONLY	SCALE ---	DESIGN UNITS METRIC	MODEL NO. 52852-***70	THIRD ANGLE PROJECTION
		DRAWN BY M. NAGATA	DATE '04/02/27	TITLE 1.0 FPC CONN NON ZIF SMT RA BOTTOM CONTACT EMBSTP -LEAD FREE-			
		CHECKED BY K. TOJO	DATE '04/02/27	MOLEX INCORPORATED			
		APPROVED BY M. SASAO	DATE '04/02/27	MATERIAL NO. SEE TABLE	DOCUMENT NO. SD-52852-011	SHEET NO. 3 OF 5	
		SIZE A3		THIS DRAWING CONTAINS INFORMATION THAT IS PROPRIETARY TO MOLEX INCORPORATED AND SHOULD NOT BE USED WITHOUT WRITTEN PERMISSION			

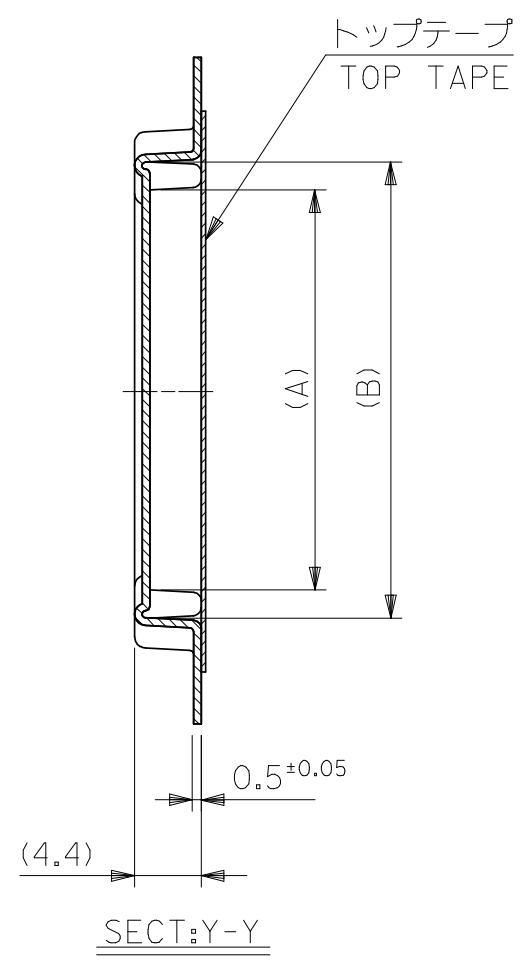
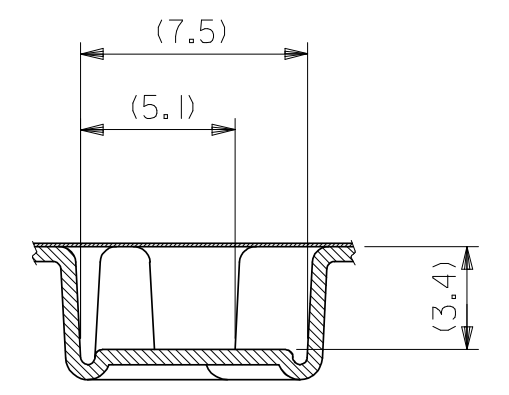
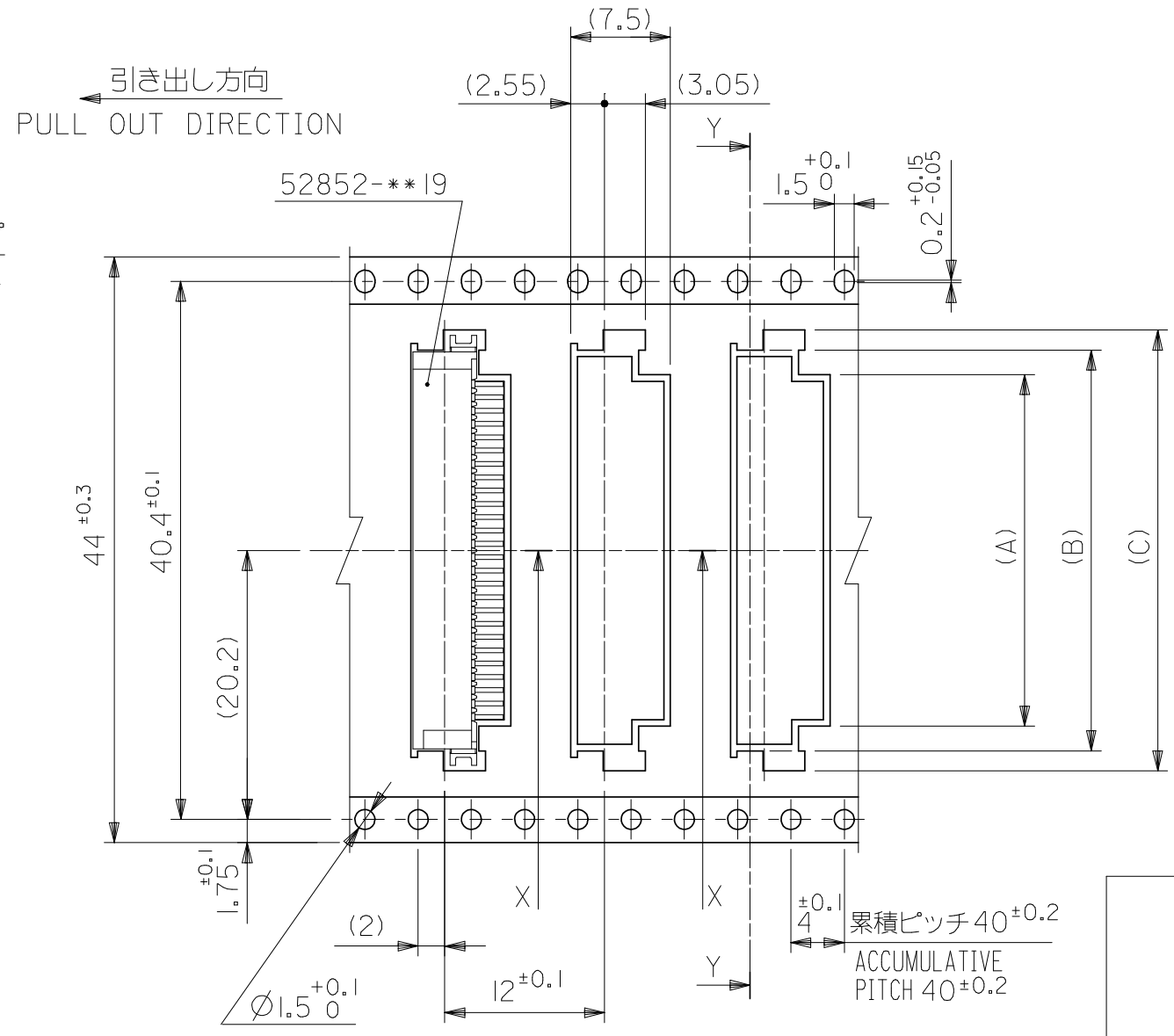

44mm幅キャリアテープ  
44mm WIDTH CARRIER TAPE

44	49.5	45.5	34.1	31.1	27.4	52852-2770	27		
			33.1	30.1	26.4	52852-2670	26		
			32.1	29.1	25.4	52852-2570	25		
			31.1	28.1	24.4	52852-2470	24		
			30.1	27.1	23.4	52852-2370	23		
			29.1	26.1	22.4	52852-2270	22		
			28.1	25.1	21.4	52852-2170	21		
			27.1	24.1	20.4	52852-2070	20		
			26.1	23.1	19.4	52852-1970	19		
			25.1	22.1	18.4	52852-1870	18		
24.1	21.1	17.4	52852-1770	17					
キャリアテープ幅 CARRIER TAPE WIDTH			E	D	(C)	(B)	(A)	MATERIAL NO.	極数 CKT.

REVISED EC NO: J2008-1818 DRWN: MNABEI 2007/11/12 CHKD: M. ISOGAYA 2007/11/13 APPR: NUKITA 2007/11/26	DESCRIPTION 10 UNDER ±0.2 10 OVER 30 UNDER ±0.25 30 OVER ±0.3 ANGULAR ±3 ° DRAFT WHERE APPLICABLE MUST REMAIN WITHIN DIMENSIONS	GENERAL TOLERANCES (UNLESS SPECIFIED)		DIMENSION STYLE MM ONLY		SCALE ---	DESIGN UNITS METRIC	MODEL NO. 52852-***70 THIRD ANGLE PROJECTION			
		DRAWN BY M. NAGATA DATE '04/02/27		CHECKED BY K. TOJO DATE '04/02/27		APPROVED BY M. SASAO DATE '04/02/27		TITLE 1.0 FPC CONN NON ZIF SMT RA BOTTOM CONTACT EMBSTP -LEAD FREE-			
		MATERIAL NO. SEE TABLE		DOCUMENT NO. SD-52852-011			SHEET NO. 4 OF 5				
		SIZE A3		THIS DRAWING CONTAINS INFORMATION THAT IS PROPRIETARY TO MOLEX INCORPORATED AND SHOULD NOT BE USED WITHOUT WRITTEN PERMISSION							
		REV A									

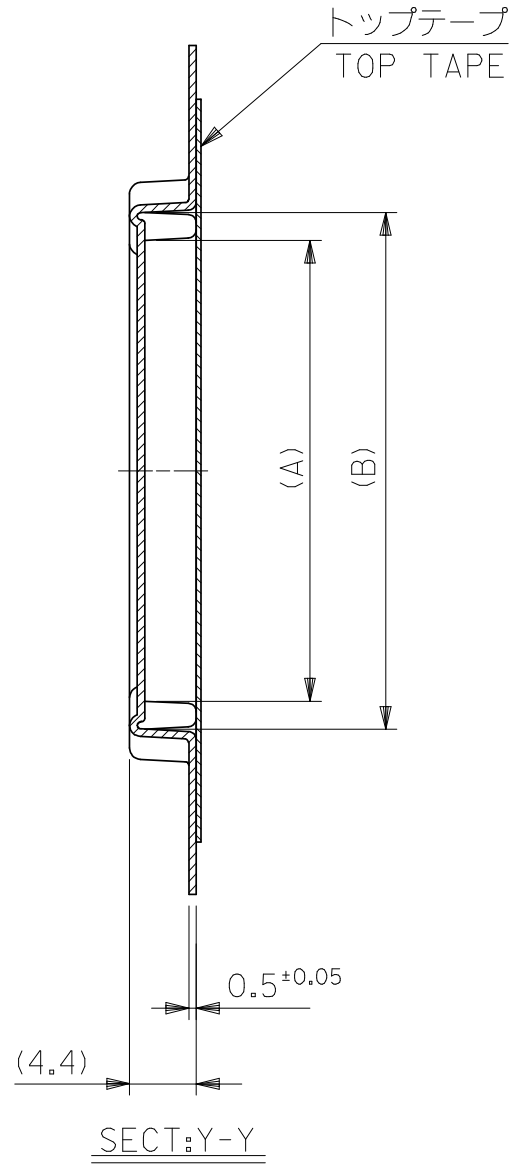
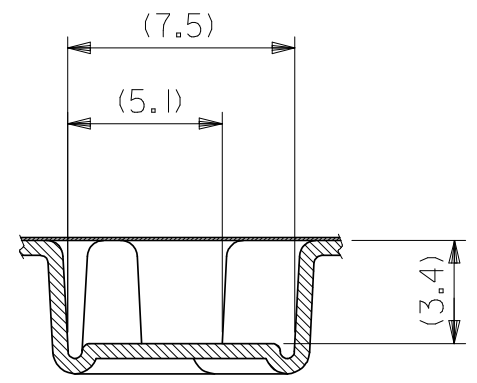
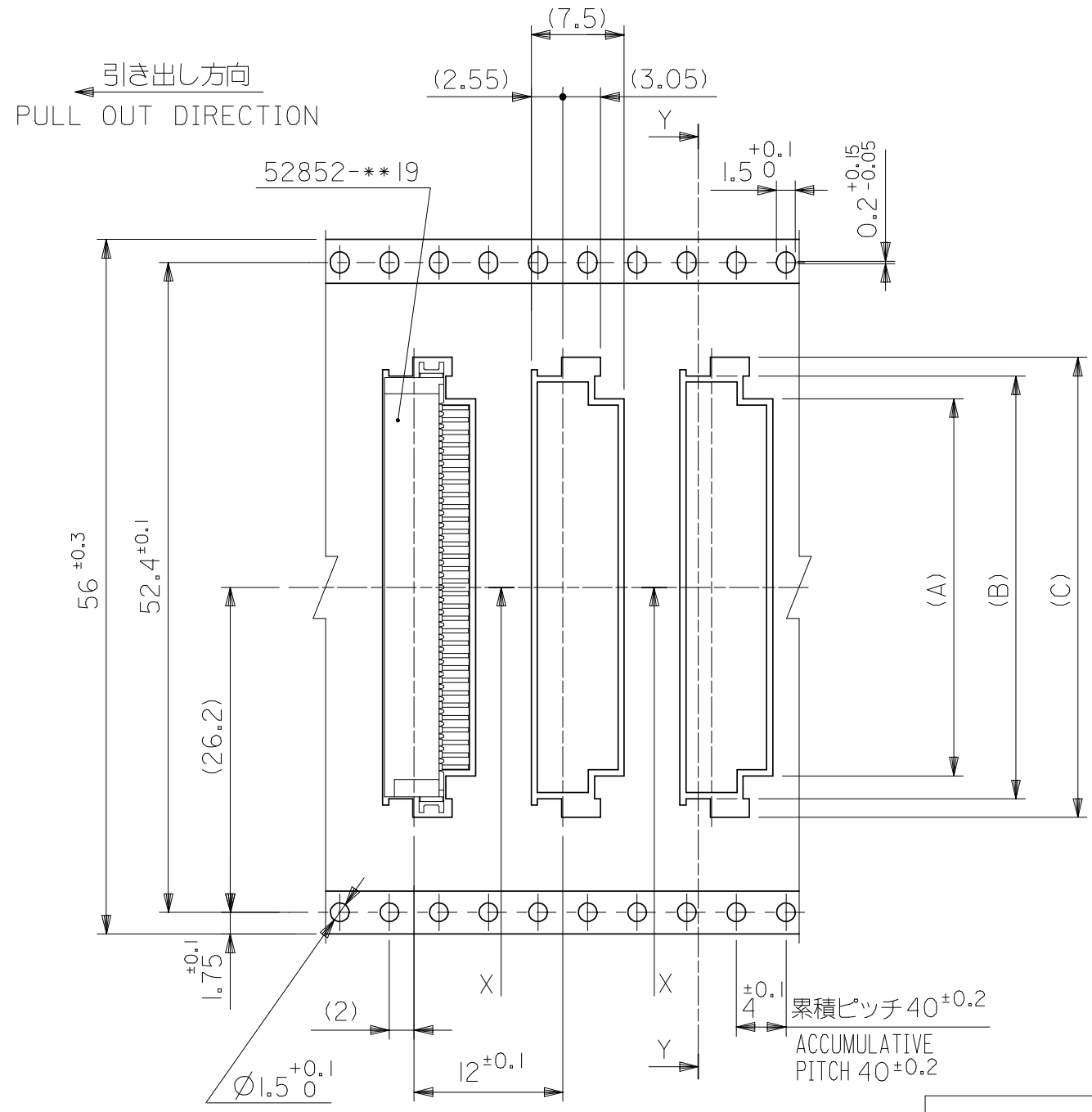

56mm幅キャリアテープ  
56mm WIDTH CARRIER TAPE

56	61.5	57.5	37.1	34.1	30.4	52852-3070	30
			36.1	33.1	29.4	52852-2970	29
			35.1	32.1	28.4	52852-2870	28
キャリアテープ幅 CARRIER TAPE WIDTH	E	D	(C)	(B)	(A)	MATERIAL NO.	極数 CKT.

REVISED EC NO: J2008-1818 DRWN: MNABEI CHKD: MISOGAYA APPR: NUKITA	DESCRIPTION 2007/11/12 2007/11/13 2007/11/26	GENERAL TOLERANCES (UNLESS SPECIFIED)		DIMENSION STYLE MM ONLY		SCALE ---	DESIGN UNITS METRIC	MODEL NO. 52852-***70	THIRD ANGLE PROJECTION	
		10 UNDER	±0.2	DRAWN BY M. NAGATA		DATE '04/02/27	TITLE 1.0 FPC CONN. N-ZIF R/A RA BOTTOM CONTACT EMBSTP -LEAD FREE-			
		10 OVER 30 UNDER	±0.25	CHECKED BY K. TOJO		DATE '04/02/27				
		30 OVER	±0.3	APPROVED BY M. SASAO		DATE '04/02/27	MOLEX INCORPORATED			
A	REV	ANGULAR ±3 °		MATERIAL NO. SEE TABLE		DOCUMENT NO. SD-52852-011		SHEET NO. 5 OF 5		
		DRAFT WHERE APPLICABLE MUST REMAIN WITHIN DIMENSIONS		THIS DRAWING CONTAINS INFORMATION THAT IS PROPRIETARY TO MOLEX INCORPORATED AND SHOULD NOT BE USED WITHOUT WRITTEN PERMISSION						