

THESE DRAWINGS ARE THE PROPERTY OF QUALTEK ELECTRONICS AND NOT TO BE REPRODUCED FOR OR COMMUNICATED TO A THIRD PARTY WITHOUT THE EXPRESS WRITTEN PERMISSION OF AN OFFICER OF QUALTEK ELECTRONICS.

REVISION			
REV.	DESCRIPTION	DATE	APPROVED

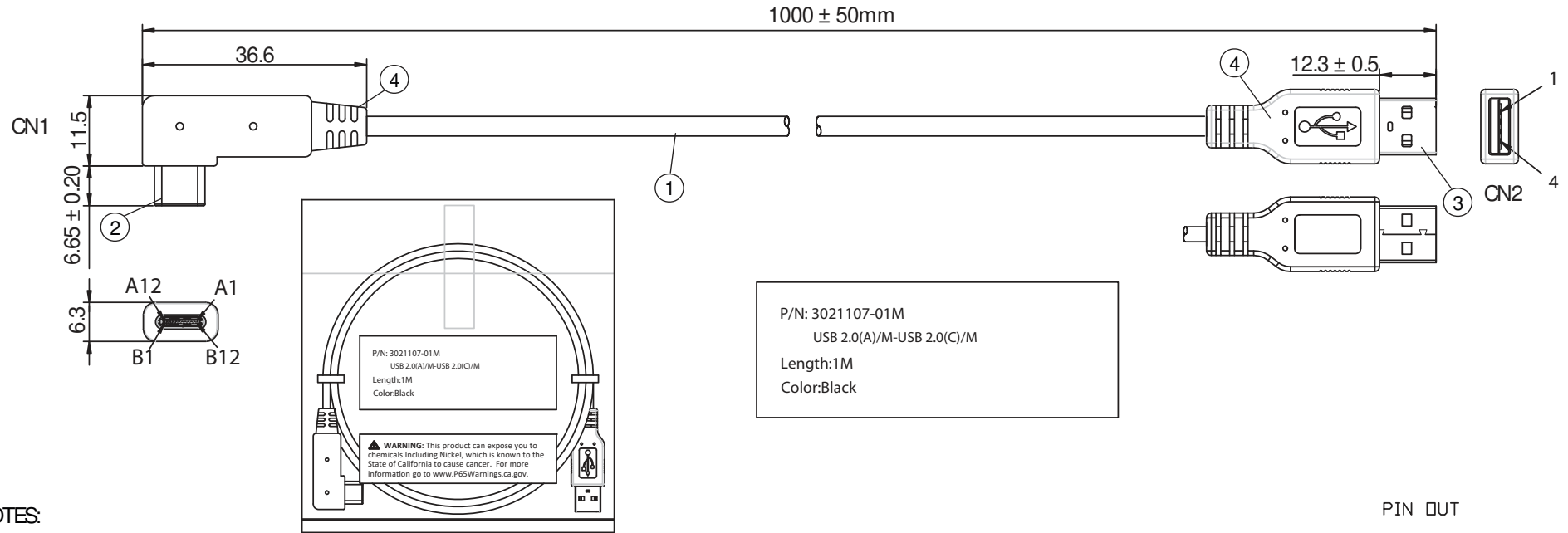

P/N: 3021107-01M
 USB 2.0(A)/M-USB 2.0(C)/M
 Length:1M
 Color:Black

NOTES:

- CABLE
 (19/0.08TA+250DNylon)x2C+(52/0.08TA+250DNylon)x1C+AB 80%
 PVC OUTER JACKET: BLACK, OD: 3.0 ± 0.2mm
- CONNECTOR: USB 2.0 TYPE C MALE
 INSULATOR: BLACK PBT
 PIN G/F
 NICKEL PLATED SHELL
- CONNECTOR: USB 2.0 A TYPE MALE
 INSULATOR: WHITE PBT
 PIN G/F
 NICKEL PLATED SHELL
- PVC MOLDED: 45P COLOR BLACK
- ELECTRICAL TEST:
 <1>.100% OPEN SHORT & MISS WIRE TEST
 <2>.HI-POT: 50V AC/0.01 SEC 50V DC/0.01 SEC
 <3>.INSULATION RESISTANCE: 10M OHM (MIN)
 <4>.CONDUCTIVE RESISTANCE: 2 OHM (MAX)
 <5>.RESISTANCE DETECTION: Rp 56Kohm ± 10% BETWEEN A4 AND A5
- DATA TRANSFER RATE UP TO 480Mbps (NOMINAL)
- CURRENT RATING UP TO 3A (NOMINAL)
- VOLTAGE RATING UP TO 5V (NOMINAL)
- PACKING: 1PC/POLYBAG/W/ LABEL

PIN OUT

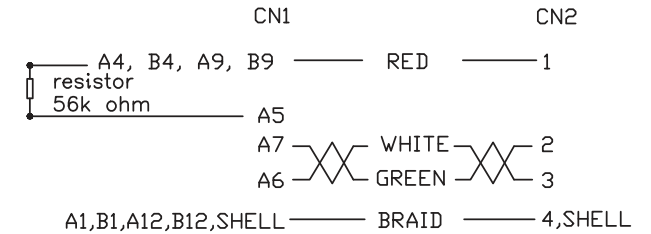

CONTROLLED

Dim range (mm)	Tolerance +/- (mm)	Qualtek Electronics Corp. WCI DIVISION		
		Part Number: 3021107-01M	RoHS Compliant	
0-1	0.15	Description: USB 2.0(C)/M LEFT ANGLE - USB 2.0 (A)/M		
1-6	0.20			
6-18	0.30	UNIT: mm		
18-50	0.50	UNIT: mm		
50-120	0.70	Drawn / Date	Checked / Date	Approved / Date
120-250	0.90	R Nuti 08-06-20	08-06-20	LY / 08-06-20
250-500	1.20			