

Product Document



austriamicrosystems AG

is now

ams AG

The technical content of this austriamicrosystems datasheet is still valid.

Contact information:

Headquarters:

ams AG
Tobelbaderstrasse 30
8141 Unterpremstaetten, Austria
Tel: +43 (0) 3136 500 0
e-Mail: ams_sales@ams.com

Please visit our website at www.ams.com

AS3675

Flexible Lighting Management Unit (Charge Pump, DCDC, 13 Current Sinks, ADC, LED Test, LDO, Audio Controlled Light)

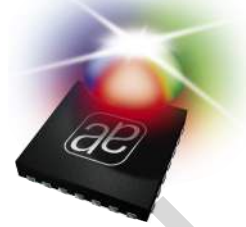

1 General Description

The AS3675 is a highly-integrated CMOS Power and Lighting Management Unit for mobile telephones, and other 1-cell Li+ or 3-cell NiMH powered devices.

The AS3675 incorporates one Step Up DC/DC Converter for white backlight LEDs, one high-power Charge Pump, one Analog-to-Digital Converter, 13 current sinks, the RGB and white LEDs can be controlled by an audio input, LED in-circuit function test, a two wire serial interface, and control logic all onto a single device. Output voltages and output currents are fully programmable.

The AS3675 is part of the austriamicrosystems AS3676, AS3687/87XM and AS3689 lighting management units family. It is software compatible to AS3687/87XM and AS3689 and pin and software compatible to AS3676.

2 Key Features

- High-Efficiency Step Up DC/DC Converter
 - Up to 16V/55mA (or 25V/35mA) for White LEDs
 - Programmable Output Voltage with External Resistors and Serial Interface
 - Over voltage Protection
- High-Efficiency High-Power Charge Pump
 - 1:1, 1:1.5, and 1:2 Mode
 - Automatic Up Switching (can be disabled and 1:2 mode can be blocked)
 - Output Current up to 300mA/500mA pulsed
 - Efficiency up to 95%
 - Very Low effective Resistance (2.5Ω typ. in 1:1.5)
 - Only 4 External Capacitors Required: 2 x 1μF Flying Capacitors, 2 x 2.2μF Input/Output Capacitors
 - Supports LCD White Backlight LEDs, or RGB LEDs
- 13 Current Sinks
 - All 13 current sinks fully Programmable (8-bit) from: 0.15mA to 38.5mA (up to 75.6mA for CURR30...CURR33)
 - Three current sinks are High Voltage capable (CURR1, CURR2, CURR6)
 - Programmable Hardware Control (Strobe, and Preview or PWM)
 - Selectively Enable/Disable Current Sinks
- Internal PWM Generation
 - 8 Bit resolution
 - Autonomous Logarithmic up/down dimming

- Led Pattern Generator
 - Autonomous driving for Fun RGB LEDs
 - Support indicator LEDs
- 10-bit Successive Approximation ADC
 - 27μs Conversion Time
 - Selectable Inputs: GPIO, all current sources, VBAT, CPOUT, DCDC_FB
 - Internal Temp. Measurement
 - Light Sensor input
- Support for automatic LED testing (open and shorted LEDs can be identified)
- Support for external Temperature Sensor for high current LED protection (CURR3x)
- Strobe Timeout protection
 - Up to 1600ms
 - Three different timing modes
- Two General Purpose Inputs/Output
 - VANA/GPI Input, GPIO Input/Output
 - Digital Input, Digital Output using VANA/GPI supply and Tristate
 - VANA/GPI internal pull down
 - GPIO Programmable Pull-Up/Down
- Programmable LDO
 - 1.85 to 3.4V, 150mA
 - Programmable via Serial Interface
- Standby LDO always on
 - Regulated 2.5V max. output 10mA
 - 3μA Quiescent Current
- Audio can be used to drive RGB LED or up to four white LEDs
 - RGB Color and Brightness is dependent on audio input amplitude or frequency
- White LEDs can be controlled by amplitude or frequency (different modes like bar-type or two and two LEDs driven by frequency filters)
- Wide Battery Supply Range: 3.0 to 5.5V
- Two Wire Serial Interface Control
- Over current and Thermal Protection
- WL-CSP30 3x2.5mm, 0.5mm pitch Package

3 Applications

Power- and lighting-management for mobile telephones and other 1-cell Li+ or 3-cell NiMH powered devices.

Figure 1. Block Diagram

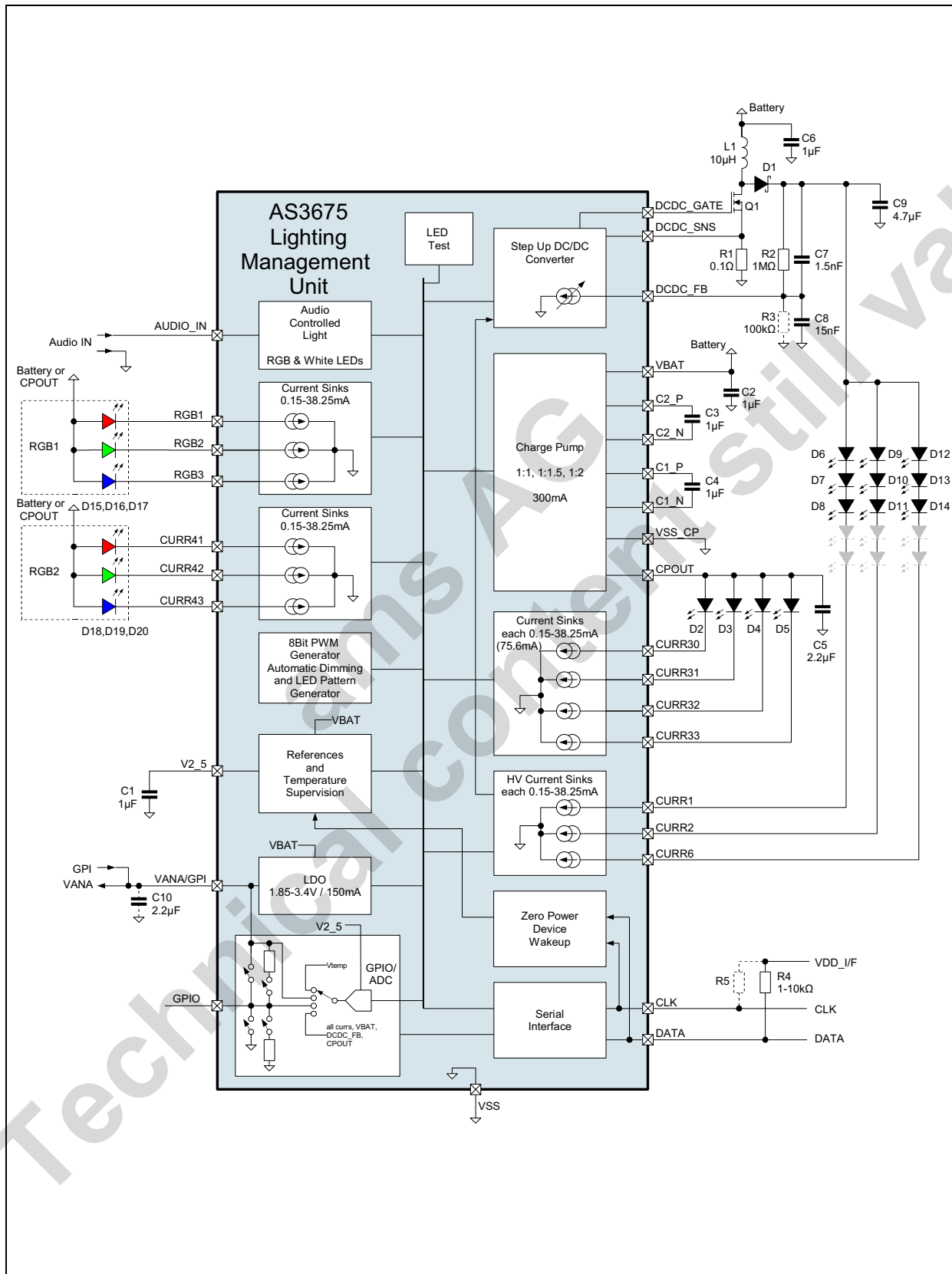

Contents

1 General Description	1
2 Key Features	1
3 Applications	1
4 Pinout	4
4.1 Pin Definitions	5
5 Absolute Maximum Ratings	6
6 Electrical Characteristics	6
7 Typical Operating Characteristics	7
8 Detailed Description	9
8.1 Analog LDO	9
8.2 Step Up DC/DC Converter	11
8.3 Charge Pump	16
8.4 Current Sinks	24
8.5 General Purpose Input / Output	46
8.6 LED Test	51
8.7 Analog-to-Digital Converter	53
8.8 Audio controlled LEDs	56
8.9 Power-On Reset	65
8.10 Temperature Supervision	67
8.11 Serial Interface	67
8.12 Operating Modes	70
9 Register Map	71
10 External Components	74
11 Package Drawings and Markings	75
11.1 Tape & Reel Information	76
12 Ordering Information	77

4 Pinout

Table 1. Pin Description for AS3675

Pin Number	Pin Name	Type	Description
A1	GPIO	AIO	General Purpose Input Output
A2	VANA/GPI	AIO	LDO Output/General Purpose Input
A3	C2_N	AIO	Charge Pump flying capacitor; connect a ceramic capacitor of 500nF to this pin.
A4	C1_P	AIO	Charge Pump flying capacitor; connect a ceramic capacitor of 500nF to this pin.
A5	CPOUT	AO	Output voltage of the Charge Pump; connect a ceramic capacitor of 1 μ F (\pm 20%).
A6	DATA	DIO	Serial interface data input/output.
B1	AUDIO_IN	AI	Audio Input
B2	VSS_CP	GND	Ground Pad for Charge Pump
B3	C1_N	AIO	Charge Pump flying capacitor; connect a ceramic capacitor of 500nF to this pin.
B4	C2_P	AIO	Charge Pump flying capacitor; connect a ceramic capacitor of 500nF to this pin.
B5	DCDC_GATE	AO	DCDC gate driver.
B6	CLK	DI	Clock input for serial interface.
C1	CURR41	AI	Analog current sink input
C2	RGB3	AI	Analog current sink input
C3	VSS	GND	Ground pad
C4	VBAT	S	Supply pad. Connect to battery.
C5	CURR30	AI	Analog current sink input, intended for activity icon LED
C6	DCDC_SNS	AI	Sense input of shunt resistor for Step Up DC/DC Converter.
D1	CURR43	AI	Analog current sink input
D2	RGB1	AI	Analog current sink input
D3	CURR33	AI	Analog current sink input, intended for activity icon LED
D4	CURR31	AI	Analog current sink input, intended for activity icon LED
D5	CURR2	AI_HV	Analog current sink input (intended for Keyboard backlight)
D6	DCDC_FB	AI	DCDC feedback. Connect to resistor string.
E1	CURR42	AI	Analog current sink input
E2	RGB2	AI	Analog current sink input
E3	CURR32	AI	Analog current sink input, intended for activity icon LED
E4	CURR6	AI_HV	Analog current sink input (intended for Keyboard backlight)
E5	CURR1	AI_HV	Analog current sink input (intended for Keyboard backlight)
E6	V2_5	AO3	Output voltage of the Low-Power LDO; always connect a ceramic capacitor of 1 μ F (\pm 20%) or 2.2 μ F (+100%/-50%). Do not load this pin during device startup.

4.1 Pin Definitions

Table 2. Pin Type Definitions

Type	Description
DI	Digital Input
DO	Digital Output
DIO	Digital Input/Output
AIO	Analog Pad
AI	Analog Input
AI_HV	High-Voltage (15V) Pin
AO3	Analog Output (3.3V)
S	Supply Pad
GND	Ground Pad

5 Absolute Maximum Ratings

Stresses beyond those listed in [Table 3](#) may cause permanent damage to the device. These are stress ratings only, and functional operation of the device at these or any other conditions beyond those indicated in [Table 4](#), “[Operating Conditions](#),” on [page 6](#) is not implied. Exposure to absolute maximum rating conditions for extended periods may affect device reliability.

Table 3. Absolute Maximum Ratings

Symbol	Parameter	Min	Max	Units	Comments
V _{IN_HV}	15V Pins	-0.3	17	V	Applicable for high-voltage current sink pins CURR1, CURR2, CURR6
V _{IN_MV}	5V Pins	-0.3	7.0	V	Applicable for 5V pins VBAT, CURR30-33, CURR41-43, RGB1-3, C1_N, C2_N, C1_P, C2_P, CPOUT, DCDC_FB, DCDC_GATE, CLK, DATA;
V _{IN_LV}	3.3V Pins	-0.3	5.0	V	Applicable for 3.3V pins V2_5; DCDC_SNS, GPIO, VANA/GPI, AUDIO_IN
	Input Pin Current	-25	+25	mA	At 25°C, Norm: JEDEC 17
T _{strg}	Storage Temperature Range	-55	125	°C	
I _{IN}	Humidity	5	85	%	Non-condensing
V _{ESD}	Electrostatic Discharge	-2000	2000	V	Norm: MIL 883 E Method 3015
P _t	Total Power Dissipation		0.75	W	TA = 70 °C, T _{junc_max} = 125°C
T _{BODY}	Peak Body Temperature		260	°C	T = 20 to 40s, in accordance with IPC/JEDEC J-STD 020.

6 Electrical Characteristics

Table 4. Operating Conditions

Symbol	Parameter	Condition	Min	Typ	Max	Unit
General Operating Conditions						
V _{HV}	High Voltage	Applicable for high-voltage current sink pins CURR1, CURR2 and CURR6.	0.0		15.0	V
V _{BAT}	Battery Voltage	Pin VBAT	3.0	3.6	5.5	V
V _{PERI}	Periphery Supply Voltage	For serial interface pins.	1.5		5.5	V
V _{2_5}	Voltage on Pin V2_5	Internally generated	2.4	2.5	2.6	V
T _{AMB}	Operating Temperature Range		-30	25	85	°C
I _{ACTIVE}	Battery current	Normal Operating current (see Operating Modes on page 71)		35		µA
I _{STANDBY}	Standby Mode Current	Current consumption in standby mode. Only 2.5V regulator on, interface active		8	13	µA
I _{SHUTDOWN}	Shutdown Mode Current	interface inactive (CLK and DATA set to 0V)		0.1	3	µA

7 Typical Operating Characteristics

Figure 2. DCDC Step Up Converter: Efficiency of +15V, Step Up to 15V vs. Load Current at VBAT=3.8V

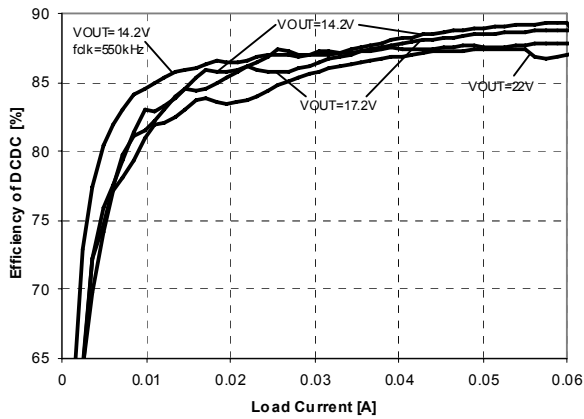

Figure 4. Charge Pump: Battery Current vs. VBAT

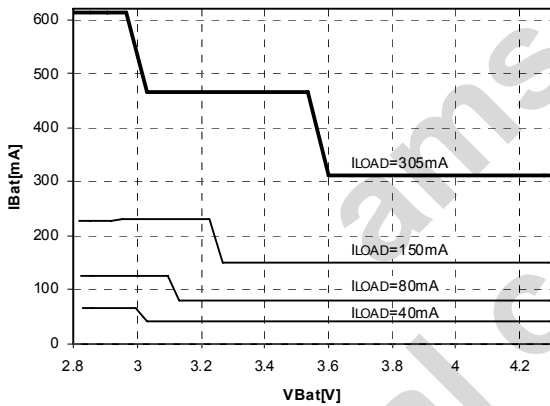

Figure 6. Current Sink CURR1 Protection Current

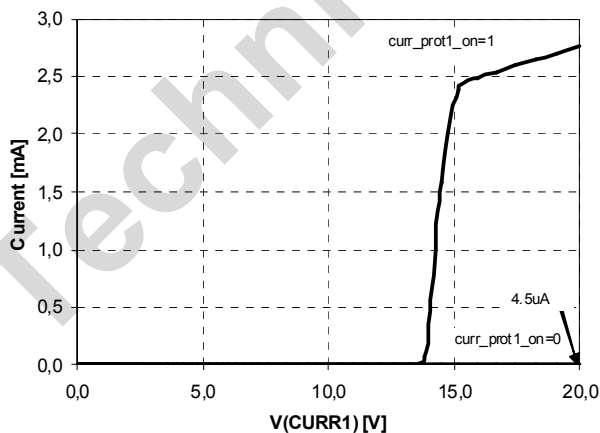

Figure 3. Charge Pump: Efficiency vs. VBAT

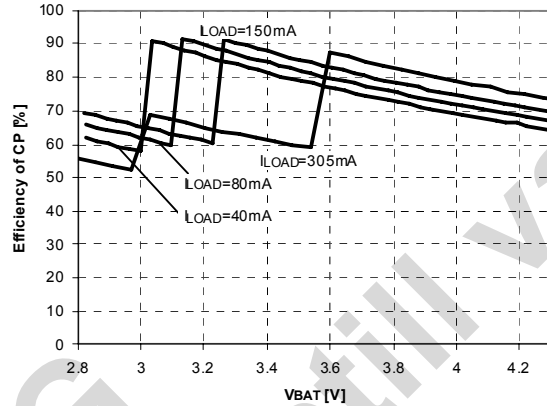

Figure 5. Current Sink CURR1 vs. V(CURRx)

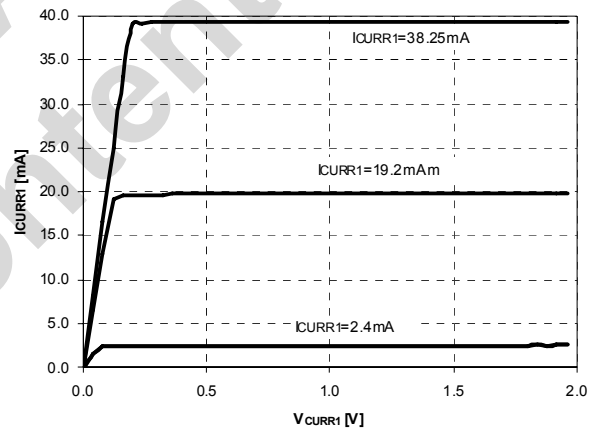

Figure 7. Current Sink CURR3x vs. VBAT

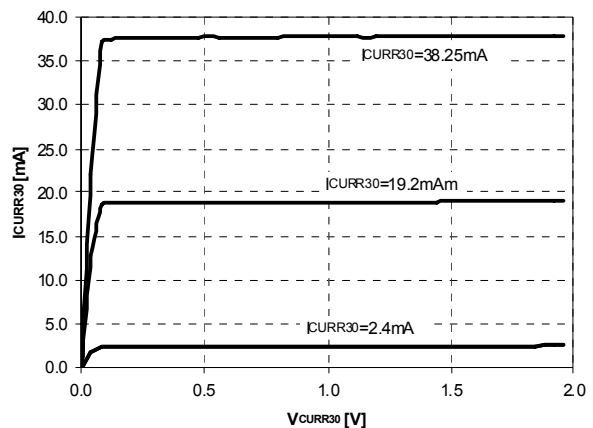

Figure 8. Charge Pump Input and Output Ripple
1:1.5 Mode, 100mA load

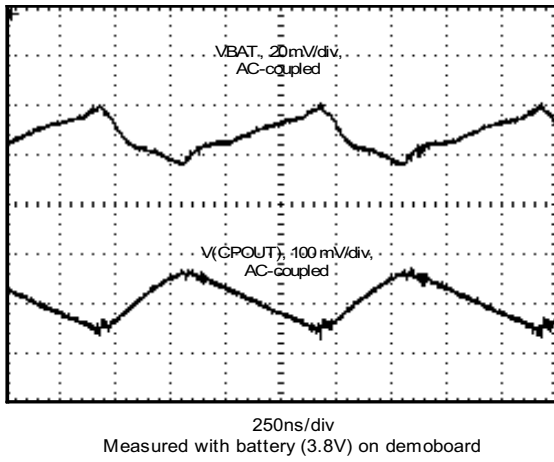

Figure 9. Charge Pump Input and Output Ripple
1:2 Mode, 100mA load

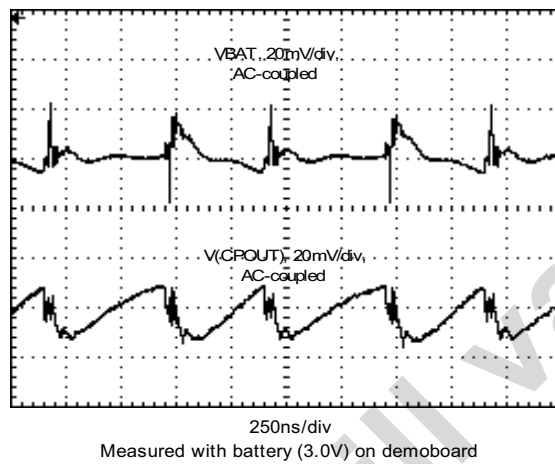
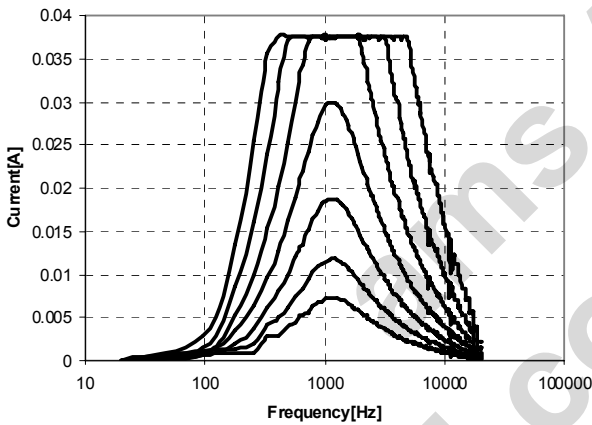

Figure 10. Characteristics frequency mode, BP filter 512/2048Hz
BP Gain +6/+4/+2/0/-2/-4/-6dB



VBAT = 3.6V, T_A = +25°C (unless otherwise specified).

8 Detailed Description

8.1 Analog LDO

The LDO is a general purpose LDO and the output pin is shared with the general purpose input (GPI) connected to VANA/GPI. The design is optimized to deliver the best compromise between quiescent current and regulator performance for battery powered devices.

Stability is guaranteed with ceramic output capacitors (of $1\mu\text{F} \pm 20\%$ (X5R) or $2.2\mu\text{F} +100/-50\%$ (Z5U)). The low ESR of these capacitors ensures low output impedance at high frequencies. The low impedance of the power transistor enables the device to deliver up to 150mA even at nearly discharged batteries without any decrease in performance.

The LDO is off by default after start-up.

Figure 11. Analog LDO Block Diagram

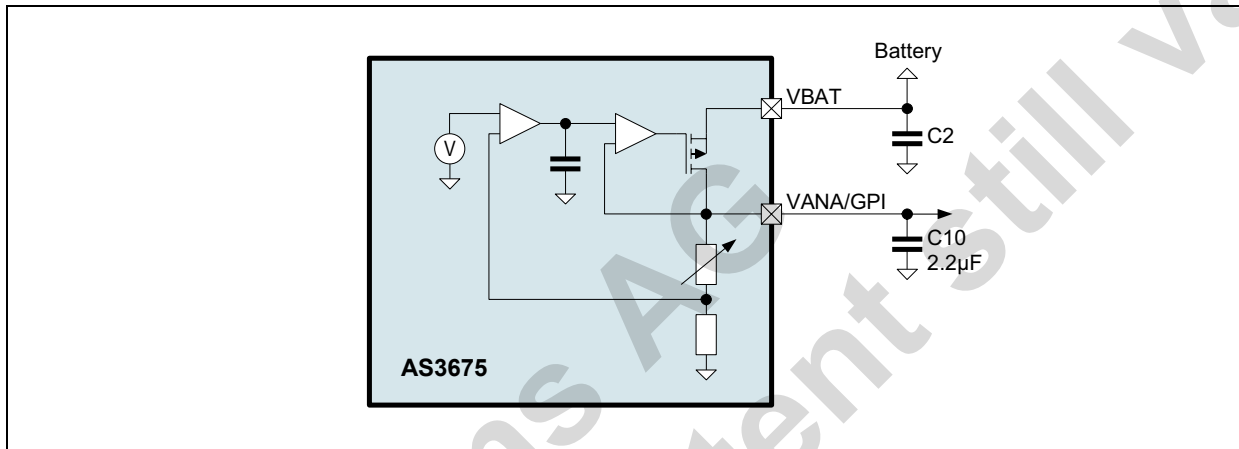

Table 5. Electrical Characteristics

Symbol	Parameter	Condition	Min	Typ	Max	Unit
V _{BAT}	Supply Voltage Range		3.0		5.5	V
R _{ON}	On Resistance	@150mA, full operating temperature range			1.0	Ω
V _{DROPOUT}	Dropout Voltage	@150mA, <i>ldo_ana_lpo</i> (see page 10)= 0			150	mV
		@50mA, <i>ldo_ana_lpo</i> = 0			50	mV
		@5mA, <i>ldo_ana_lpo</i> = 1			500	mV
I _{ON}	Supply Current	Without load		50		µA
		Without load, <i>ldo_ana_lpo</i> = 1 <i>ldo_ana</i> only		3		
		With 150mA load		150		
I _{OFF}	Shutdown Current	Without load			100	nA
t _{start}	Start-up Time				200	µs
V _{out_tol}	Output Voltage Tolerance		-3		+3	%
V _{OUT}	Output Voltage	V _{BAT} > 3.0V and I _{OUT} =150mA	1.8		2.85	V
		Full Programmable Range	1.8		3.35	V
I _{LIMIT} ¹	LDO Current Limit <i>ldo_ana_lpo</i> = 0	Pin VANA. LDO acts as current source if the output current exceeds I _{LIMIT} .	300	450 ²		mA
	LDO Current Limit <i>ldo_ana_lpo</i> = 1	V _{BAT} -V _{VANA} ≥0.2V	4	8		mA

1. Not production tested – guaranteed by design and laboratory verification
2. During startup of the LDO the current limit is half the value of I_{LIMIT}

8.1.1 LDO Registers

Table 6. *Reg. control Register*

Addr: 00		Reg. control			
This register enables/disables the LDOs, Charge Pumps, Charge Pump LEDs, current sinks, the Step Up DC/DC Converter, and low-power mode.					
Bit	Bit Name	Default	Access	Description	
0	ldo_ana_on	0	R/W	0	Analog LDO is switched off
				1	Analog LDO is switched on
7	ldo_ana_lpo	0	R/W	0	Normal Operation
				1	Low-power mode; current consumption is reduced by about 75µA. Reduced performance of LDO: max 5mA load, internal oscillator is switched off. The device will exit low-power mode automatically, if blocks requiring the oscillator are enabled.

Table 7. *LDO ANA1 Voltage Register*

Addr: 07h		LDO ANA1 Voltage			
This register sets the output voltage (VANA) for the LDO.					
Bit	Bit Name	Default	Access	Description	
4:0	ldo_ana_voltage	00000b	R/W	Controls LDO voltage selection.	
				00000b	1.85V
				...	LSB=50mV
				11111b	3.4V

8.2 Step Up DC/DC Converter

The Step Up DC/DC Converter is a high-efficiency current mode PWM regulator, providing output voltage up to e.g. 25V/35mA or e.g. 16V/55mA. A constant switching-frequency results in a low noise on the supply and output voltages.

Figure 12. Step Up DCDC Converter Block Diagram Option: Current Feedback with Over voltage protection

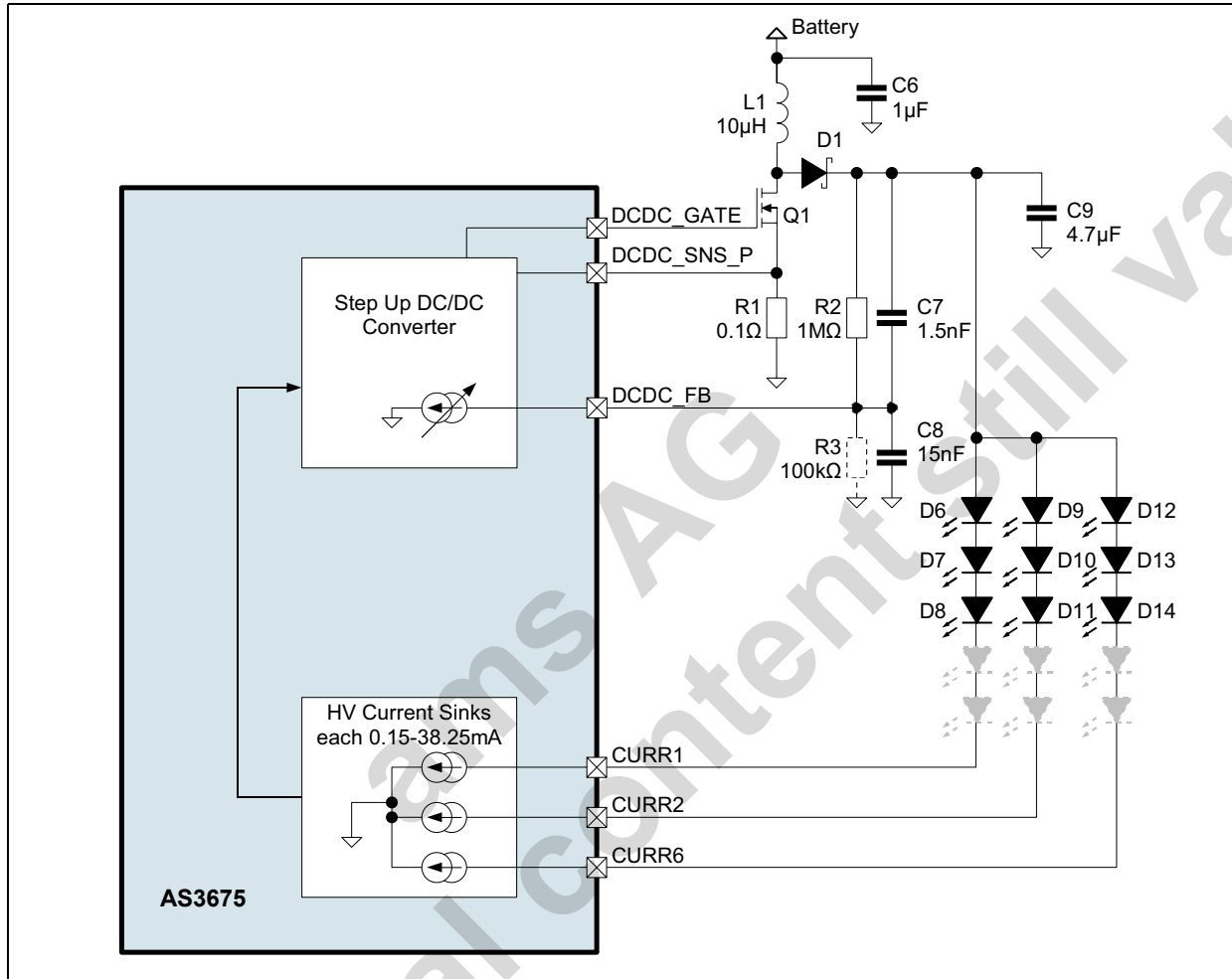

Table 8. Step Up DC/DC Converter Parameters

Symbol	Parameter	Condition	Min	Typ	Max	Unit
I _{VDD}	Quiescent Current	Pulse skipping mode.		140		µA
V _{FB1}	Feedback Voltage for External Resistor Divider	For constant voltage control. <i>step_up_res</i> = 1	1.20	1.25	1.30	V
V _{FB2}	Feedback Voltage for Current Sink Regulation	on CURR1, CURR2 or CURR6 in regulation. <i>step_up_res</i> = 0	0.4	0.5	0.6	V
I _{DCDC_FB}	Additional Tuning Current at Pin DCDC_FB and over voltage protection	Adjustable by software using Register DCDC control1 1µA step size (0-31µA) V _{PROTECT} = 1.25V + I _{DCDC_FB} * R2	0		31	µA
	Accuracy of Feedback Current at full scale		-6		6	%

Table 8. Step Up DC/DC Converter Parameters

Symbol	Parameter	Condition	Min	Typ	Max	Unit
V _{sense_max}	Current Limit Voltage at R1	e.g., 0.66A for 0.1Ω sense resistor.	46	66	85	mV
		For fixed startup time of 500us	25	33	43	
		If <code>Step_up_lowcur= 1</code>	30	43	57	
R _{SW}	Switch Resistance	ON-resistance of external switching transistor.			1	Ω
I _{LOAD}	Load Current	At 16V output voltage	0		55	mA
		At 25V output voltage	0		35	
f _{IN}	Switching Frequency	Internally trimmed	0.9	1	1.1	MHz
C _{OUT}	Output Capacitor	Ceramic, ±20%. Use nominal 4.7μF capacitors to obtain at least 0.7μF under all conditions (voltage dependence of capacitors)	0.7	4.7		μF
L	Inductor	Use inductors with small C _{parasitic} (<100pF) to get high efficiency.	7	10	13	μH
t _{MIN_ON}	Minimum on Time		90	140	190	ns
MDC	Maximum Duty Cycle		88	91		%
V _{ripple}	Voltage ripple >20kHz	C _{out} =4.7μF, I _{out} =0..45mA, V _{BAT} =3.0...4.2V			160	mV
	Voltage ripple <20kHz				40	mV
Efficiency	Efficiency	I _{out} =20mA, V _{out} =17V, V _{BAT} =3.8V		85		%

To ensure soft startup of the dc/dc converter, the over current limits are reduced for a fixed time after enabling the dc/dc converter. The total startup time for an output voltage of e.g. 25V is less than 2ms.

8.2.1 Feedback Selection

Register `DCDC control1` and `DCDC control2` selects the type of feedback for the Step Up DC/DC Converter.

The feedback for the DC/DC converter can be selected either by current sinks (CURR1, CURR2, CURR6) or by a voltage feedback at pin DCDC_FB. If the register bit `step_up_fb_auto` is set, the feedback path is automatically selected between CURR1, CURR2 and CURR6 (the lowest voltage of these current sinks is used).

Setting `step_up_fb` enables feedback on the pins CURR1, CURR2 or CURR6. The Step Up DC/DC Converter is regulated such that the required current at the feedback path can be supported. (Bit `step_up_res` should be set to 0 in this configuration)

Note: Always choose the path with the highest voltage drop as feedback to guarantee adequate supply for the other (unregulated) paths or enable the register bit `step_up_fb_auto`.

8.2.2 Over voltage Protection in Current Feedback Mode

The over voltage protection in current feedback mode (`step_up_fb = 01, 10 or 11` or `step_up_fb_auto = 1`) works as follows: Only resistor R2 and C7/C8 is soldered and R3 is omitted. An internal current source (sink) is used to generate a voltage drop across the resistor R2. If then the voltage on DCDC_FB is above 1.25V, the DCDC is momentarily disabled to avoid too high voltages on the output of the DCDC converter.

The protection voltage can be calculated according to the following formula:

$$V_{PROTECT} = 1.25V + I_{DCDC_FB} * R_2 \quad (EQ 1)$$

Note: The voltage on the pin DCDC_FB is limited by an internal protection diode to V_{BAT} + one diode forward voltage (typ. 0.6V).

If the over voltage protection is not used in current feedback mode, connect DCDC_FB to ground.

Figure 13. Step Up DC/DC Converter Detail Diagram; Option: Regulated Output Current, Feedback is automatically selected between CURRE1, CURRE2, CURRE6 ($step_up_fb_auto=1$); over voltage protection is enabled ($step_up_prot=1$); 1MHz clock frequency ($step_up_freq=0$)

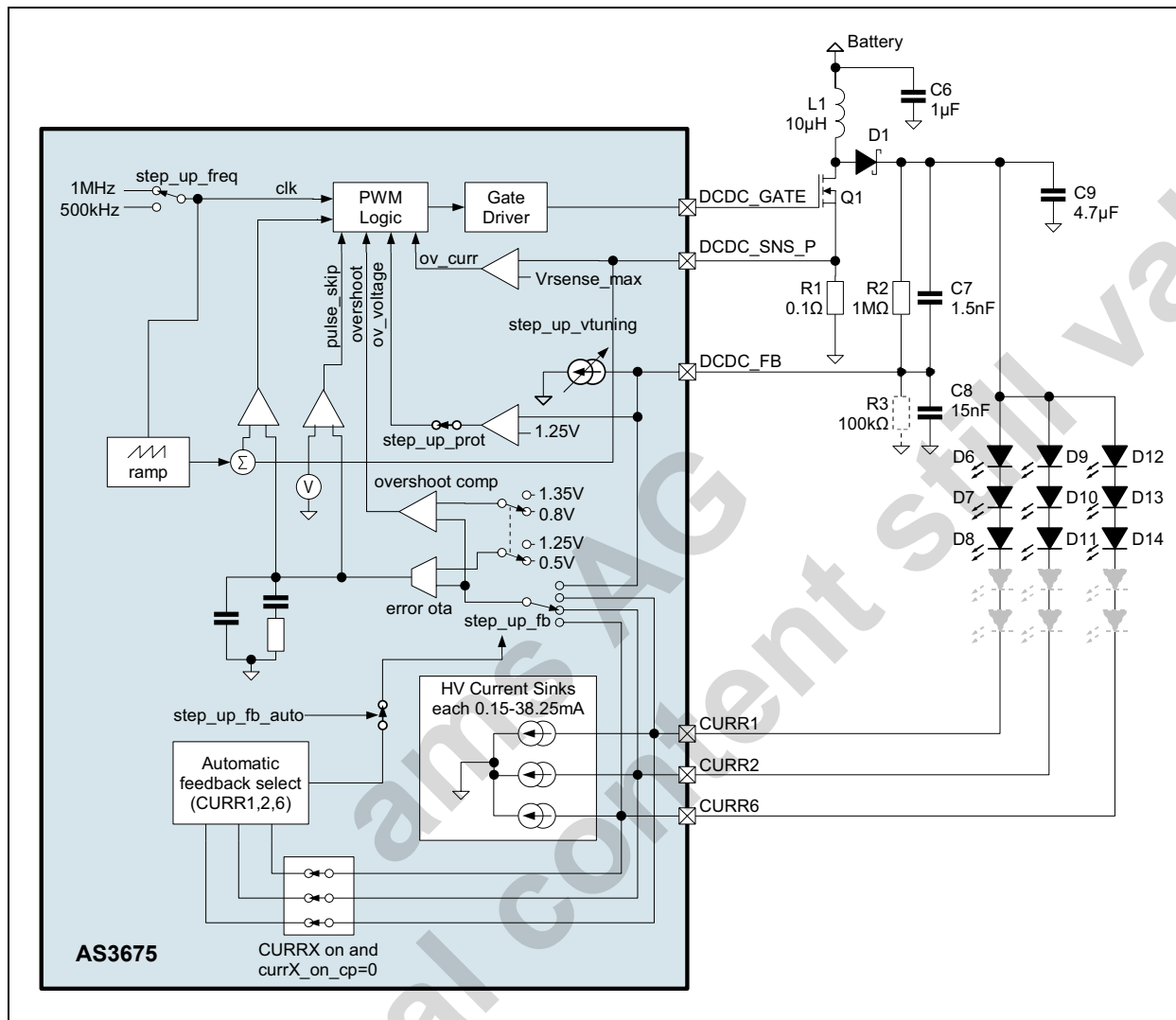

8.2.3 Voltage Feedback

Setting bit $step_up_fb$ (see page 15) = 00 enables voltage feedback at pin DCDC_FB.

The output voltage is regulated to a constant value, given by (Bit $step_up_res$ should be set to 1 in this configuration)

$$U_{Step\ up_out} = (R_2+R_3)/R_3 * 1.25 + I_{DCDC_FB} * R_2 \quad (EQ\ 2)$$

If R4 is not used, the output voltage is by (Bit $step_up_res$ should be set to 0 in this configuration)

$$U_{Step\ up_out} = 1.25 + I_{DCDC_FB} * R_2 \quad (EQ\ 3)$$

Where:

$U_{Step\ up_out}$ = Step Up DC/DC Converter output voltage

R2 = Feedback resistor R2

R3 = Feedback resistor R3

IdCDC_FB = Tuning current at ball DCDC_FB; 0 to 31 μ A

Table 9. Voltage Feedback Example Values

IDCDC_FB	UStep up_out	
	R2 = 1M Ω , R3 not used	R2 = 500k Ω , R3 = 50k Ω
μ A		
0	-	13.75
1	-	14.25
2	-	14.75
3	-	15.25
4	-	15.75
5	6.25	16.25
6	7.25	16.75
7	8.25	17.25
8	9.25	17.75
9	10.25	18.25
10	11.25	18.75
11	12.25	19.25
12	13.25	19.75
13	14.25	20.25
14	15.25	20.75
15	16.25	21.25
...
30	31.25	28.75
31	32.25	29.25

Note: The voltage on CURR1, CURR2 and CURR6 must not exceed 15V (see page 25)

8.2.4 PCB Layout Hints

To ensure good EMC performance of the DCDC converter, keep its external power components C6, R1, L1, Q1, D1 and C9 close together. Connect the ground of C6, R1 and C9 locally together and connect this with a short path to AS3675 VSS. This ensures that local high-frequency currents will not flow to the battery.

8.2.5 Step up Registers

Table 10. Reg. control Register

Addr: 00		Reg. control			
This register enables/disables the Charge Pump and the Step Up DC/DC Converter.					
Bit	Bit Name	Default	Access	Description	
3	step_up_on	0	R/W	Enable the step up converter	
				0b	Disable the Step Up DC/DC Converter
				1b	Enable the Step Up DC/DC Converter

Table 11. DCDC control1 Register

Addr: 21h		DCDC control1			
This register controls the Step Up DC/DC Converter.					
Bit	Bit Name	Default	Access	Description	
0	step_up_frequ	0	R/W	Defines the clock frequency of the Step Up DC/DC Converter.	
				0	1MHz
				1	500kHz
2:1	step_up_fb	00	R/W	Controls the feedback source if step_up_fb_auto = 0	
				00	DCDC_FB enabled (external resistor divider). Set step_up_fb=00 (DCDC_FB)
				01	CURR1 feedback enabled (feedback via LEDs)
				10	CURR2 feedback enabled (feedback via LEDs)
				11	CURR6 feedback enabled (feedback via LEDs)
7:3	step_up_vtuning	00000	R/W	Defines the tuning current at pin DCDC_FB.	
				00000	0 μ A
				00001	1 μ A
				00010	2 μ A
				
				10000	15 μ A
				
				11111	31 μ A

Table 12. DCDC control2 Register

Addr: 22h		DCDC control2			
This register controls the Step Up DC/DC Converter and low-voltage current sinks CURR3x.					
Bit	Bit Name	Default	Access	Description	
0	step_up_res	0	R/W	Gain selection for Step Up DC/DC Converter	
				0	Select 0 if Step Up DC/DC Converter is used with current feedback (CURR1, CURR2, CURR6) or if DCDC_FB is used with current feedback only – R2, C7, C8 connected, R3 not used
				1	Select 1 if DCDC_FB is used with external resistor divider using 2 resistors: R2 and R3
1	skip_fast	0	R/W	Step Up DC/DC Converter output voltage at low loads, when pulse skipping is active	
				0	Accurate output voltage, more ripple
				1	Elevated output voltage, less ripple
2	step_up_prot	1	R/W	Step Up DC/DC Converter protection	
				0	No over voltage protection
				1	Over voltage protection on pin DCDC_FB enabled voltage limitation = 1.25V on DCDC_FB

Table 12. DCDC control2 Register

Addr: 22h		DCDC control2			
		This register controls the Step Up DC/DC Converter and low-voltage current sinks CURR3x.			
Bit	Bit Name	Default	Access	Description	
3	Step up_lowcur	1	R/W	Step Up DC/DC Converter coil current limit	
				0	Normal current limit
				1	Current limit reduced by approx. 33%
7	step_up_fb_auto	0	R/W	0	step_up_fb select the feedback of the DCDC converter
				1	The feedback is automatically chosen within the current sinks CURR1, CURR2 and CURR6 (never DCDC_FB). Only those are used for this selection, which are enabled (currX_mode must not be 00) and not connected to the charge pump (currX_on_cp must be 0).

8.3 Charge Pump

The Charge Pump uses two external flying capacitors C3, C4 to generate output voltages higher than the battery voltage. There are three different operating modes of the charge pump itself:

- 1:1 Bypass Mode
 - Battery input and output are connected by a low-impedance switch
 - battery current = output current.
- 1:1.5 Mode
 - The output voltage is up to 1.5 times the battery voltage (without load), but is limited to VCPOUTmax all the time
 - battery current = 1.5 times output current.
- 1:2 Mode
 - The output voltage is up to 2 times the battery voltage (without load), but is limited to VCPOUTmax all the time
 - battery current = 2 times output current

As the battery voltage decreases, the Charge Pump must be switched from 1:1 mode to 1:1.5 mode and eventually in 1:2 mode in order to provide enough supply for the current sinks. Depending on the actual current the mode with best overall efficiency can be automatically or manually selected:

Examples:

- Battery voltage = 3.7V, LED dropout voltage = 3.5V. The 1:1 mode will be selected and there is 200mV drop on the current sink and on the Charge Pump switch. Efficiency 95%.
- Battery voltage = 3.5V, LED dropout voltage = 3.5V. The 1:1.5 mode will be selected and there is 1.5V drop on the current sink and 250mV on the Charge Pump. Efficiency 66%.
- Battery voltage = 3.8V, LED dropout voltage = 4.5V (Camera Flash). The 1:2 mode can be selected and there is 600mV drop on the current sink and 2.5V on the Charge Pump. Efficiency 60%.

The efficiency is dependent on the LED forward voltage given by:

$$Eff = (V_{LED} \cdot I_{out}) / (U_{in} \cdot I_{in}) \quad (EQ 4)$$

The charge pump mode switching can be done manually or automatically with the following possible software settings:

- Automatic up all modes allowed (1:1, 1:1.5, 1:2)
 - Start with 1:1 mode
 - Switch up automatically 1:1 to 1:1.5 to 1:2
- Automatic up, but only 1:1 and 1:1.5 allowed
 - Start with 1:1 mode
 - Switch up automatically only from 1:1 to 1:1.5 mode; 1:2 mode is not used
- Manual
 - Set modes 1:1, 1:1.5, 1:2 by software

Figure 14. Charge Pump Pin Connections

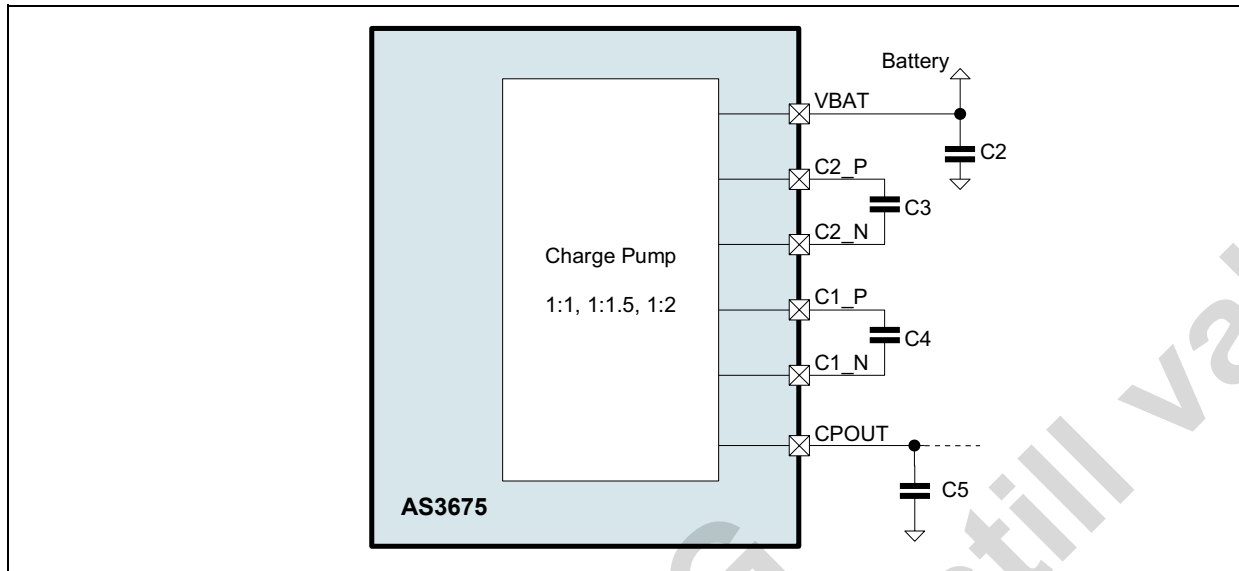

The Charge Pump requires the external components listed in the following table:

Table 13. Charge Pump External Components

Symbol	Parameter	Condition	Min	Typ	Max	Unit
C2	External Decoupling Capacitor	Ceramic low-ESR capacitor between pins VBAT and VSS.		1.0		μF
C3, C4	External Flying Capacitor (2x)	Ceramic low-ESR capacitor between pins C1_P and C1_N, between pins C2_P and C2_N and between VBAT and VSS		1.0		μF
C5	External Storage Capacitor	Ceramic low-ESR capacitor between pins CPOUT and VSS, pins CPOUT and VSS. Use nominal 2.2 μF capacitors (size 0603)		2.2		μF

Note: The connections of the external capacitors C2, C3, C4 and C5 should be kept as short as possible.

The maximum voltage on the flying capacitors C3 and C4 is VBAT.

Table 14. Charge Pump Characteristics

Symbol	Parameter	Condition	Min	Typ	Max	Unit
ICPOUT	Output Current Continuous	Depending on PCB layout	0.0		300	mA
	Output Current Pulsed	max. 200ms $V_{CPOUT} = V_{BAT} * CP_{MODE} - I_{LOAD} * R_{CP}$	0.0		500	mA
VCPOUTmax	Output Voltage	Internally limited, Including output ripple			5.6	V
η	Efficiency	Including current sink loss; ICPOUT < 100mA.	60		90	%
ICP1_1.5	Power Consumption without Load fclk = 1 MHz	1:1.5 Mode		3.4		mA
ICP1_2		1:2 Mode		3.8		
Rcp1_1	Effective Charge Pump Output Resistance (Open Loop, fclk = 1MHz)	1:1 Mode; VBAT \geq 3.5V		0.57		Ω
Rcp1_1.5		1:1.5 Mode; VBAT \geq 3.3V		2.65		
Rcp1_2		1:1.2 Mode; VBAT \geq 3.1V		3.25		
fclk Accuracy	Accuracy of Clock Frequency		-10		10	%

Table 14. Charge Pump Characteristics

Symbol	Parameter	Condition	Min	Typ	Max	Unit
currhv_switch	CURR1, 2, 6 minimum voltage				0.45	V
currlv_switch	CURR30-33, RGB1-3, CURR41-3 minimum voltage	If the voltage drops below this threshold, the charge pump will use the next available mode (1:1 -> 1:1.5 or 1:1.5 -> 1:2)			0.2	V
	CURR30-33 0-75.6mA range for strobe if <code>curr3x_strobe_high=1</code>				0.4	V
tdeb	CP automatic up- switching debounce time	<code>cp_start_debounce=0</code>		240		µsec
		After switching on CP (<code>cp_on</code> set to 1), if <code>cp_start_debounce=1</code>		2000		µsec

8.3.1 Charge Pump Mode Switching

If automatic mode switching is enabled (`cp_mode_switching` (see page 20) = 00 or `cp_mode_switching` = 01) the charge pump monitors the current sinks, which are connected via a led to the output CPOUT. To identify these current sources (sinks), the registers `CP mode Switch1` and `CP mode Switch2` (register bits `curr30_on_cp` (see page 21) ... `curr33_on_cp`, `rgb1_on_cp` ... `rgb3_on_cp`, `curr1_on_cp`, `curr2_on_cp`, `curr41_on_cp` ... `curr43_on_cp` and `curr6_on_cp`) should be setup before starting the charge pump (`cp_on` (see page 20) = 1). If any of the voltage on these current sources drops below the threshold (`currlv_switch`, `currhv_switch`), the next higher mode is selected after the debounce time.

To avoid switching into 1:2 mode (battery current = 2 times output current), set `cp_mode_switching` = 01.

If the `currX_on_cp=0` and the according current sink is connected to the charge pump, the current sink will be functional, but there is no up switching of the charge pump, if the voltage compliance is too low for the current sink to supply the specified current.

Figure 15. Automatic Mode Switching

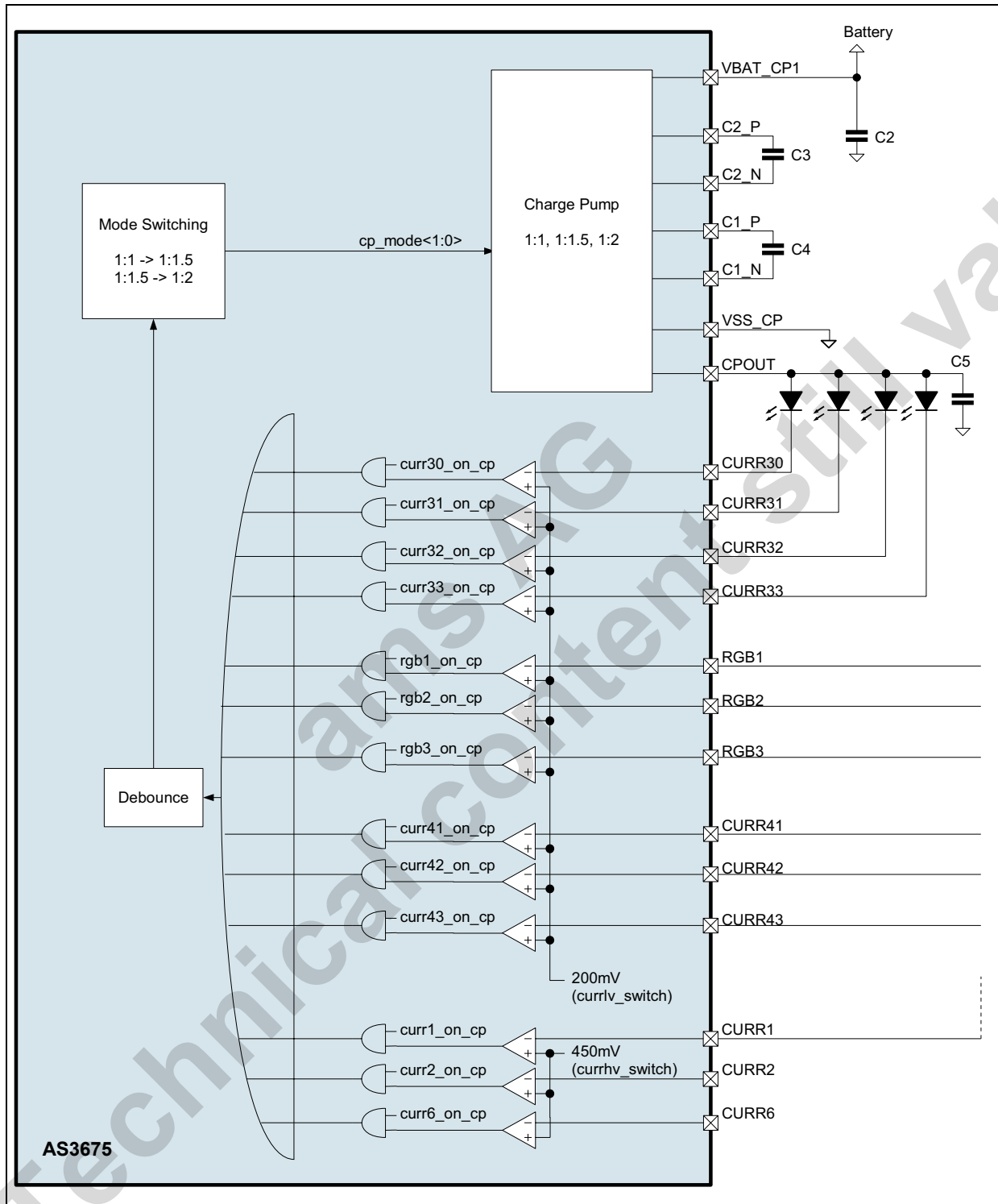

8.3.2 Soft Start

An implemented soft start mechanism reduces the inrush current. Battery current is smoothed when switching the charge pump on and also at each switching condition. This precaution reduces electromagnetic radiation significantly.

8.3.3 Charge Pump Registers

Table 15. *Reg. control* Register

Addr: 00h		Reg. control			
This register controls the Charge Pump.					
Bit	Bit Name	Default	Access	Description	
2	cp_on	0	R/W	0	Set Charge Pump into 1:1 mode (off state) unless cp_auto_on is set
				1	Enable manual or automatic mode switching

Table 16. *CP control* Register

Addr: 23h		CP control			
This register enables/disables the Charge Pump and the Step Up DC/DC Converter.					
Bit	Bit Name	Default	Access	Description	
0	cp_clk	0	R/W	Clock frequency selection.	
				0	1 MHz
				1	500 kHz
2:1	cp_mode	00b	R/W	Charge Pump mode (in manual mode sets this mode, in automatic mode reports the actual mode used) ¹	
				00	1:1 mode
				01	1:1.5 mode
				10	1:2 mode
				11	NA
4:3	cp_mode_switching	00b	R/W	Set the mode switching algorithm	
				00	Automatic Mode switching; 1:1, 1:1.5 and 1:2 allowed
				01	Automatic Mode switching; only 1:1 and 1:1.5 allowed
				10	Manual Mode switching; register cp_mode defines the actual charge pump mode used
				11	Reserved
5	cp_start_debounce	0	R/W	0	Mode switching debounce timer is always 240µs
				1	Upon startup (cp_on set to 1) the mode switching debounce time is first started with 2ms then reduced to 240µs
6	cp_auto_on	0	R/W	0	Charge Pump is switched on/off with cp_on
				1	Charge Pump is automatically switched on if a current sink, which is connected to the charge pump (defined by registers CP Mode Switch 1 & 2) is switched on

1. Direct switching from 1:1.5 mode into 1:2 in manual mode and vice versa is not allowed. Always switch over 1:1 mode.

Table 17. CP mode Switch1 Register

Addr: 24h		CP mode Switch1			
		Setup which current sinks are connected (via leds) to the charge pump; if set to '1' the correspond current source (sink) is used for automatic mode selection of the charge pump			
Bit	Bit Name	Default	Access	Description	
0	curr30_on_cp	0	R/W	0	current Sink CURR30 is not connected to charge pump
				1	current sink CURR30 is connected to charge pump
1	curr31_on_cp	0	R/W	0	current Sink CURR31 is not connected to charge pump
				1	current sink CURR31 is connected to charge pump
2	curr32_on_cp	0	R/W	0	current Sink CURR32 is not connected to charge pump
				1	current sink CURR32 is connected to charge pump
3	curr33_on_cp	0	R/W	0	current Sink CURR33 is not connected to charge pump
				1	current sink CURR33 is connected to charge pump
4	rgb1_on_cp	0	R/W	0	current Sink RGB1 is not connected to charge pump
				1	current sink RGB1 is connected to charge pump
5	rgb2_on_cp	0	R/W	0	current Sink RGB2 is not connected to charge pump
				1	current sink RGB2 is connected to charge pump
6	rgb3_on_cp	0	R/W	0	current Sink RGB3 is not connected to charge pump
				1	current sink RGB3 is connected to charge pump

Table 18. CP mode Switch2 Register

Addr: 25h		CP mode Switch2			
		Setup which current sinks are connected (via LEDs) to the charge pump; if set to '1' the correspond current source (sink) is used for automatic mode selection of the charge pump			
Bit	Bit Name	Default	Access	Description	
0	curr1_on_cp	0	R/W	0	current Sink CURR1 is not connected to charge pump
				1	current sink CURR1 is connected to charge pump
1	curr2_on_cp	0	R/W	0	current Sink CURR2 is not connected to charge pump
				1	current sink CURR2 is connected to charge pump
2	curr41_on_cp	0	R/W	0	current Sink CURR41 is not connected to charge pump
				1	current sink CURR41 is connected to charge pump
3	curr42_on_cp	0	R/W	0	current Sink CURR42 is not connected to charge pump
				1	current sink CURR42 is connected to charge pump

Table 18. CP mode Switch2 Register (Continued)

Addr: 25h		CP mode Switch2			
		Setup which current sinks are connected (via LEDs) to the charge pump; if set to '1' the correspond current source (sink) is used for automatic mode selection of the charge pump			
Bit	Bit Name	Default	Access	Description	
4	curr43_on_cp	0	R/W	0	current Sink CURR43 is not connected to charge pump
				1	current sink CURR43 is connected to charge pump
7	curr6_on_cp	0	R/W	0	current Sink CURR6 is not connected to charge pump
				1	current sink CURR6 is connected to charge pump

Table 19. Curr low voltage status1 Register

Addr: 2Ah		Curr low voltage status1			
		Indicates the low voltage status of the current sinks. If the currX_low_v bit is set, the voltage on the current sink is too low, to drive the selected output current			
Bit	Bit Name	Default	Access	Description	
0	curr30_low_v	NA	R	0	voltage of current Sink CURR30 >currlv_switch
				1	voltage of current Sink CURR30 <currlv_switch
1	curr31_low_v	NA	R	0	voltage of current Sink CURR31 >currlv_switch
				1	voltage of current Sink CURR31 <currlv_switch
2	curr32_low_v	NA	R	0	voltage of current Sink CURR32 >currlv_switch
				1	voltage of current Sink CURR32 <currlv_switch
3	curr33_low_v	NA	R	0	voltage of current Sink CURR33 >currlv_switch
				1	voltage of current Sink CURR33 <currlv_switch
4	rgb1_low_v	NA	R	0	voltage of current Sink RGB1 >currlv_switch
				1	voltage of current Sink RGB1 <currlv_switch
5	rgb2_low_v	NA	R	0	voltage of current Sink RGB2 >currlv_switch
				1	voltage of current Sink RGB2 <currlv_switch
6	rgb3_low_v	NA	R	0	voltage of current Sink RGB3 >currlv_switch
				1	voltage of current Sink RGB31 <currlv_switch
7	curr6_low_v	NA	R	0	voltage of current Sink CURR6 >currlv_switch
				1	voltage of current Sink CURR6 <currlv_switch

Table 20. Curr low voltage status2 Register

Addr: 2Bh		Curr low voltage status2			
		Indicates the low voltage status of the current sinks. If the currX_low_v bit is set, the voltage on the current sink is too low, to drive the selected output current			
Bit	Bit Name	Default	Access	Description	
0	curr1_low_v	NA	R	0	voltage of current Sink CURR1 >currhv_switch
				1	voltage of current Sink CURR1 <currhv_switch

Table 20. Curr low voltage status2 Register (Continued)

Addr: 2Bh		Curr low voltage status2			
		Indicates the low voltage status of the current sinks. If the currX_low_v bit is set, the voltage on the current sink is too low, to drive the selected output current			
Bit	Bit Name	Default	Access	Description	
1	curr2_low_v	NA	R	0	voltage of current Sink CURRE2 >currhv_switch
				1	voltage of current Sink CURRE2 <currhv_switch
2	curr41_low_v	NA	R	0	voltage of current Sink CURRE41 >currlv_switch
				1	voltage of current Sink CURRE41 <currlv_switch
3	curr42_low_v	NA	R	0	voltage of current Sink CURRE42 >currlv_switch
				1	voltage of current Sink CURRE42 <currlv_switch
4	curr43_low_v	NA	R	0	voltage of current Sink CURRE43 >currlv_switch
				1	voltage of current Sink CURRE43 <currlv_switch

8.4 Current Sinks

The AS3675 contains general purpose current sinks intended to control RGB LEDs, white LEDs (e.g. backlights) and can also be used for buzzers or vibrators. All current sinks have an integrated over voltage protection.

CURR1, CURR2 and CURR6 are also used as feedback for the Step Up DC/DC Converter (regulated to 0.5V in this configuration) see [Feedback Selection on page 12](#).

- Current sinks CURR1, CURR2 and CURR6 are high-voltage compliant (15V) current sinks, used e.g., for series of white LEDs
- Current sinks CURR3x (CURR30, CURR31, CURR32 and CURR33) are parallel 5V current sinks, used for back-lighting, indicator LEDs or RGB LEDs.
- Current sinks RGB1, RGB2, and RGB3 are general purpose current sinks e.g. for a fun LED.
- Current sinks CURR4x (CURR41, CURR42, and CURR43) are general purpose current sinks.

Table 21. Current Sink Function Overview

Current Sink	Max. Voltage (V)	Max. Current (mA)	Resolution		Software Current Control	Hardware On/Off Control	Can be assigned to Audio Controlled LED Channel
			(Bits)	(mA)			
CURR1	15.0	38.25	8	0.15	Separate	LED Pattern; Internal PWM	ch1
CURR2							ch2
CURR6							ch3
CURR30	VBAT (5.5V)	38.25 (75.6mA for strobe if <code>curr3x_strobe_high=1</code>)	8	0.15	Combined in Strobe/Preview or Separated	Flash LED Strobe (CURR1 or CURR30) & Preview (CURR2); Internal PWM; LED Pattern	Completely individual assignment of the audio channels ch1, ch2 and ch3 to the outputs
CURR31							
CURR32							
CURR33							
RGB1		38.25	8	0.15	Separate	LED Pattern; Internal PWM	ch1
RGB2							ch2
RGB3							ch3
CURR41		38.25	8	0.15	Separate	LED Pattern; Internal PWM	ch1
CURR42							ch2
CURR43							ch3

8.4.1 High Voltage Current Sinks CURR1, CURR2, CURR6

The high voltage current sinks have a resolution of 8 bits. Additionally an internal protection circuit monitors with a voltage divider (max 3µA @ 15V) the voltage on CURR1, CURR2 and CURR6 and increases the current in off state in case of over voltage.

Table 22. HV Current Sinks Characteristics

Symbol	Parameter	Condition	Min	Typ	Max	Unit
I _{BIT7}	Current sink if Bit7 = 1	For V(CURRx) > 0.45V		19.2		mA
I _{BIT6}	Current sink if Bit6 = 1			9.6		
I _{BIT5}	Current sink if Bit5 = 1			4.8		
I _{BIT4}	Current sink if Bit4 = 1			2.4		
I _{BIT3}	Current sink if Bit3 = 1			1.2		
I _{BIT2}	Current sink if Bit2 = 1			0.6		
I _{BIT1}	Current sink if Bit1 = 1			0.3		
I _{BIT0}	Current sink if Bit0 = 1			0.15		
Δm	matching Accuracy	CURR1,CURR2,CURR6	-10		+10	%
Δ	absolute Accuracy		-15		+15	%
V _{CURR1,2,6x}	Voltage compliance		0.45		15	V
Ov_prot_13V	Over voltage Protection of current sink CURR1,2,6	At 13V, independent of curr1_prot_on, curr2_prot_on or curr6_prot_on			3.0	µA
Ov_prot_15V	Over voltage Protection of current sink CURR1,2,6	At 15V, step_up_on=1, curr1_prot_on=1 for CURR1, curr2_prot_on=1 for CURR2, curr6_prot_on=1 for CURR6	0.8		4.0	mA

High Voltage Current Sinks CURR1, CURR2, CURR6 Registers

Table 23. Curr1 current Register

Addr: 09h		Curr1 current			
This register controls the High voltage current sink current.					
Bit	Bit Name	Default	Access	Description	
7:0	curr1_current	0	R/W	Defines current into current sink curr1	
				00h	0 mA
				01h	0.15 mA
			
				FFh	38.25 mA

Table 24. Curr2 current Register

Addr: 0Ah		Curr2 current			
This register controls the High voltage current sink current.					
Bit	Bit Name	Default	Access	Description	
7:0	curr2_current	0	R/W	Defines current into current sink curr2	
				00h	0 mA
				01h	0.15 mA
			
				FFh	38.25 mA

Table 25. curr6 current Register

Addr: 2Fh		curr6 current			
This register controls the High voltage current sink current.					
Bit	Bit Name	Default	Access	Description	
7:0	curr6_current	0	R/W	Defines current into current sink CURR6	
				00h	0 mA
				01h	0.15 mA
			
				FFh	38.25 mA

Table 26. curr12 control Register

Addr: 01h		curr12 control			
This register select the mode of the current sinks controls High voltage current sink current.					
Bit	Bit Name	Default	Access	Description	
1:0	curr1_mode	0	R/W	Select the mode of the current sink curr1	
				00b	off
				01b	on
				10b	PWM controlled
				11b	LED pattern controlled
3:2	curr2_mode	0	R/W	Select the mode of the current sink curr2	
				00b	off
				01b	on
				10b	PWM controlled
				11b	LED pattern controlled

Table 27. *curr rgb control* Register

Addr: 02h		curr rgb control			
This register select the mode of the current sinks CURR6.					
Bit	Bit Name	Default	Access	Description	
7:6	curr6_mode	0	R/W	Select the mode of the current sink CURR6	
				00b	off
				01b	on
				10b	PWM controlled
				11b	LED pattern controlled

Table 28. *DCDC control2* Register

Addr: 22h		DCDC control2			
This register controls the Step Up DC/DC Converter and low-voltage current sinks CURR3x.					
Bit	Bit Name	Default	Access	Description	
4	curr1_prot_on	0	R/W	0	No over voltage protection
				1	Pull down current on CURR1 switched on, if voltage on CURR1 exceeds 13.75V, and step_up_on=1
5	curr2_prot_on	0	R/W	0	No over voltage protection
				1	Pull down current on CURR2 switched on, if voltage exceeds on CURR2 13.75V, and step_up_on=1
6	curr6_prot_on	0	R/W	0	No over voltage protection
				1	Pull down current on CURR6 switched on, if voltage on CURR6 exceeds 13.75V, and step_up_on=1

8.4.2 Current Sinks CURR30, CURR31, CURR32, CURR33

These current sinks have a resolution of 8 bits and can sink up to 38.25mA. The current values can be controlled individually with `curr30_current` – `curr33_current` or common with `curr3x_strobe` or `curr3x_preview`.

Table 29. *Current Sinks CURR30,31,32,33 Parameters*

Symbol	Parameter	Condition	Min	Typ	Max	Unit
I _{BIT7}	Current sink if Bit7 = 1	For V(CURR3x) > 0.2V		19.2		mA
I _{BIT6}	Current sink if Bit6 = 1			9.6		
I _{BIT5}	Current sink if Bit5 = 1			4.8		
I _{BIT4}	Current sink if Bit4 = 1			2.4		
I _{BIT3}	Current sink if Bit3 = 1			1.2		
I _{BIT2}	Current sink if Bit2 = 1			0.6		
I _{BIT1}	Current sink if Bit1 = 1			0.3		
I _{BIT0}	Current sink if Bit0 = 1			0.15		
Δ _m	matching Accuracy	CURR30-33	-10		+10	%
Δ	absolute Accuracy		-15		+15	%
V _{CURR3X}	Voltage compliance		0.2		CPO UT	V
		<code>curr3x_strobe_high=1</code> and strobe function	0.4			

Current Sinks CURR3x Registers

Table 30. Curr3 control2 Register

Addr: 12h		Curr3 control2			
This register selects the modes of the current sinks30..33 current.					
Bit	Bit Name	Default	Access	Description	
0	preview_off_after_strobe	0b	R/W	Select the switch off mode after strobe pulse	
				0	normal preview/strobe mode
				1	switch off preview after strobe duration has expired. To reinitiate the torch mode the preview_ctrl has to be set off and on again
2:1	preview_ctrl	00b	R/W	Preview is triggered by	
				00b	off
				01b	software trigger (setting this bit automatically triggers preview)
				10b	CURR2 active high; set gpi_curr2_en=1
5	curr3x_strobe_high	0b	R/W	Double current on CURR30...CURR33 during strobe function	
				0	normal strobe current (0-37.8mA)
				1	double strobe current (0-75.6mA)
7	strobe_pin	0	R/W	Select strobe input pin and current sink outputs (only if strobe_ctrl=10 or 11)	
				0	CURR1 is strobe input; CURR30...CURR33 flash output; set gpi_curr1_en=1
				1	CURR30 is strobe input; CURR1, CURR2, CURR6 flash output; set gpi_curr30_en=1

Table 31. Curr3 strobe control Register

Addr: 11h		Curr3 strobe control			
This register selects the modes of the current sinks30..33 current.					
Bit	Bit Name	Default	Access	Description	
1:0	strobe_ctrl	00b	R/W	Strobe is triggered by	
				00b	off
				01b	software trigger (setting this bit automatically triggers strobe)
				10b	CURR1 (or CURR30 see strobe_pin) active high
3:2	strobe_mode	00b	R/W	Selects strobe mode	
				00b	Mode1 (Tstrobe=Ts; strobe trigger signal ≥ 10µs)
				01b	Mode 2 (Tstrobe=max Ts)
				10b	Mode 3 (Tstrobe = strobe signal)
				11b	not used

Table 31. *Curr3 strobe control Register (Continued)*

Addr: 11h		Curr3 strobe control			
This register selects the modes of the current sinks30..33 current.					
Bit	Bit Name	Default	Access	Description	
7:4	strobe_timing	0000b	R/W	Selects strobe time (Ts)	
				0000b	100 msec
				0001b	200 msec
				0010b	300 msec
				0011b	400 msec
				0100b	500 msec
				0101b	600 msec
				0110b	700 msec
				0111b	800 msec
				1000b	900 msec
				1001b	1000 msec
				1010b	1100 msec
				1011b	1200 msec
				1100b	1300 msec
				1101b	1400 msec
				1110b	1500 msec
1111b	1600 msec				

Table 32. *Curr3x strobe Register*

Addr: 0Eh		Curr3x strobe			
This register selects the strobe current of the current sinks30..33					
Bit	Bit Name	Default	Access	Description	
5:0	curr3x_strobe	00	R/W	Defines Strobe current of Current sinks curr30-33	
				00h	0 mA
				01h	0.6 mA (1.2mA if curr3x_strobe_high=1)
			
				3Fh	37.8 mA (75.6mA if curr3x_strobe_high=1)

Table 33. *Curr3x preview Register*

Addr: 0Fh		Curr3x preview			
This register selects the preview current of the current sinks30..33					
Bit	Bit Name	Default	Access	Description	
5:0	curr3x_preview	00	R/W	Defines Preview current of Current sinks curr30-33	
				00h	0 mA
				01h	0.6 mA
			
				3Fh	37.8 mA

Table 34. Curr3x other Register

Addr: 10h		Curr3x other			
This register selects the current of the current sinks30..33					
Bit	Bit Name	Default	Access	Description	
5:0	curr3x_other	00	R/W	Selects curr30 current, if curr30 is not used for strobe/preview (curr30_mode=11b)	
				00h	0 mA
				01h	0.6 mA
			
				3Fh	37.8 mA

Table 35. Curr30 current Register

Addr: 40h		Curr30 current			
This register selects the current of the current sink30					
Bit	Bit Name	Default	Access	Description	
7:0	curr30_current	00	R/W	Selects curr30 current, if curr30 is not used for strobe/preview (curr30_mode=11b)	
				00h	0 mA
				01h	0.15 mA
			
				FFh	38.25 mA

Table 36. Curr31 current Register

Addr: 41h		Curr31 current			
This register selects the current of the current sink31					
Bit	Bit Name	Default	Access	Description	
7:0	curr31_current	00	R/W	Selects curr30 current, if curr30 is not used for strobe/preview (curr31_mode=11b)	
				00h	0 mA
				01h	0.15 mA
			
				FFh	38.25 mA

Table 37. Curr32 current Register

Addr: 42h		Curr32 current			
This register selects the current of the current sink32					
Bit	Bit Name	Default	Access	Description	
7:0	curr32_current	00	R/W	Selects CURR32 current, if CURR32 is not used for strobe/preview (curr32_mode=11b)	
				00h	0 mA
				01h	0.15 mA
			
				FFh	38.25 mA

Table 38. Curr33 current Register

Addr: 43h		Curr33 current			
This register selects the current of the current sink33					
Bit	Bit Name	Default	Access	Description	
7:0	curr33_current	00	R/W	Selects curr33 current, if curr33 is not used for strobe/preview (curr33_mode=11b)	
				00h	0 mA
				01h	0.15 mA
			
				FFh	38.25 mA

Table 39. curr3 control1 Register

Addr: 03h		curr3 control1			
This register select the mode of the current sinks30 - 33					
Bit	Bit Name	Default	Access	Description	
1:0	curr30_mode	0	R/W	Select the mode of the current sink curr30	
				00b	off
				01b	strobe/preview
				10b	curr30_current or curr3x_other PWM controlled
				11b	curr30_current or curr3x_other - don't use curr3x_other if softdim_pattern=1, use curr30_current instead
3:2	curr31_mode	0	R/W	Select the mode of the current sink curr31	
				00b	off
				01b	strobe/preview
				10b	curr31_current or curr3x_other PWM controlled
				11b	curr31_current - don't use curr3x_other if softdim_pattern=1, use curr31_current instead
5:4	curr32_mode	0	R/W	Select the mode of the current sink CURR32	
				00b	off
				01b	strobe/preview
				10b	curr32_current or curr3x_other PWM controlled
				11b	curr32_current or curr3x_other - don't use curr3x_other if softdim_pattern=1, use curr32_current instead
7:6	curr33_mode	0	R/W	Select the mode of the current sink curr33	
				00b	off
				01b	strobe/preview
				10b	curr33_current or curr3x_other PWM controlled
				11b	curr33_current or curr3x_other - don't use curr3x_other if softdim_pattern=1, use curr33_current instead

Table 40. Pattern control Register

Addr: 18h		Pattern control			
This register controls the LED pattern					
Bit	Bit Name	Default	Access	Description	
4	curr30_pattern	0b	R/W	Additional CURR33 LED pattern control bit	
				0b	CURR30 controlled according curr30_mode register
				1b	CURR30 controlled by LED pattern generator
5	curr31_pattern	0b	R/W	Additional CURR33 LED pattern control bit	
				0b	CURR31 controlled according curr31_mode register
				1b	CURR31 controlled by LED pattern generator
6	curr32_pattern	0b	R/W	Additional CURR33 LED pattern control bit	
				0b	CURR32 controlled according curr33_mode register
				1b	CURR32 controlled by LED pattern generator
7	curr33_pattern	0b	R/W	Additional CURR33 LED pattern control bit	
				0b	CURR33 controlled according curr33_pattern register
				1b	CURR33 controlled by LED pattern generator

8.4.3 Current Sinks RGB1, RGB2, RGB3

These current sinks have a resolution of 8 bits and can sink up to 38.25mA.

Table 41. Current Sinks RGB1, RGB2, RGB3 Parameters

Symbol	Parameter	Condition	Min	Typ	Max	Unit
I _{BIT7}	Current sink if Bit7 = 1	For V(RGBx) > 0.2V		19.2		mA
I _{BIT6}	Current sink if Bit6 = 1			9.6		
I _{BIT5}	Current sink if Bit5 = 1			4.8		
I _{BIT4}	Current sink if Bit4 = 1			2.4		
I _{BIT3}	Current sink if Bit3 = 1			1.2		
I _{BIT2}	Current sink if Bit2 = 1			0.6		
I _{BIT1}	Current sink if Bit1 = 1			0.3		
I _{BIT0}	Current sink if Bit0 = 1			0.15		
Δm	matching Accuracy	RGB1, RGB2, RGB3	-10		+10	%
Δ	absolute Accuracy		-15		+15	%
V _{RGBX}	Voltage compliance		0.2		CPO UT	V

RGB Current Sinks Registers

Table 42. *curr rgb control* Register

Addr: 02h		curr rgb control			
This register select the mode of the current sinks RGB1, RGB2, RGB3					
Bit	Bit Name	Default	Access	Description	
1:0	rgb1_mode	0	R/W	Select the mode of the current sink RGB1	
				00b	off
				01b	on
				10b	PWM controlled
				11b	LED pattern controlled
3:2	rgb2_mode	0	R/W	Select the mode of the current sink RGB2	
				00b	off
				01b	on
				10b	PWM controlled
				11b	LED pattern controlled
5:4	rgb3_mode	0	R/W	Select the mode of the current sink RGB3	
				00b	off
				01b	on
				10b	PWM controlled
				11b	LED pattern controlled

Table 43. *Rgb1 current* Register

Addr: 0Bh		Rgb1 current			
This register controls the RGB current sink current.					
Bit	Bit Name	Default	Access	Description	
7:0	rgb1_current	0	R/W	Defines current into Current sink RGB1	
				00h	0 mA
				01h	0.15 mA
			
				FFh	38.25 mA

Table 44. *Rgb2 current* Register

Addr: 0Ch		Rgb2 current			
This register controls the RGB current sink current.					
Bit	Bit Name	Default	Access	Description	
7:0	rgb2_current	0	R/W	Defines current into Current sink RGB2	
				00h	0 mA
				01h	0.15 mA
			
				FFh	38.25 mA

Table 45. *Rgb3 current Register*

Addr: 0Dh		Rgb3 current			
This register controls the RGB current sink current.					
Bit	Bit Name	Default	Access	Description	
7:0	rgb3_current	0	R/W	Defines current into Current sink RGB3	
				00h	0 mA
				01h	0.15 mA
			
				FFh	38.25 mA

8.4.4 General Purpose Current Sinks CURR4x

These low voltage current sinks have a resolution of 8 bits and can sink up to 38.25mA.

Table 46. *CURR4x Sinks Characteristics*

Symbol	Parameter	Condition	Min	Typ	Max	Unit
I _{BIT7}	Current sink if Bit7 = 1	For V(CURRx) > 0.2V		19.2		mA
I _{BIT6}	Current sink if Bit6 = 1			9.6		
I _{BIT5}	Current sink if Bit5 = 1			4.8		
I _{BIT4}	Current sink if Bit4 = 1			2.4		
I _{BIT3}	Current sink if Bit3 = 1			1.2		
I _{BIT2}	Current sink if Bit2 = 1			0.6		
I _{BIT1}	Current sink if Bit1 = 1			0.3		
I _{BIT0}	Current sink if Bit0 = 1			0.15		
Δm	matching Accuracy	CURR1,CURR2	-10		+10	%
Δ	absolute Accuracy		-15		+15	%
V _{CURR41,42,43x}	Voltage compliance		0.2		CPO UT	V

General Purpose Current Sinks CURR4x Registers

Table 47. *curr4 control Register*

Addr: 04h		curr4 control			
This register selects the mode of the current sinks CURR41, CURR42, CURR43					
Bit	Bit Name	Default	Access	Description	
1:0	curr41_mode	0	R/W	Select the mode of the current sink CURR41	
				00b	off
				01b	on
				10b	PWM controlled
				11b	LED pattern controlled

Table 47. *curr4 control Register (Continued)*

Addr: 04h		curr4 control			
This register selects the mode of the current sinks CURR41, CURR42, CURR43					
Bit	Bit Name	Default	Access	Description	
3:2	curr42_mode	0	R/W	Select the mode of the current sink CURR42	
				00b	off
				01b	on
				10b	PWM controlled
5:4	curr43_mode	0	R/W	Select the mode of the current sink CURR43	
				00b	off
				01b	on
				10b	PWM controlled
				11b	LED pattern controlled

Table 48. *Curr41 current Register*

Addr: 13h		Curr41 current			
This register controls the curr41 current sink current.					
Bit	Bit Name	Default	Access	Description	
7:0	curr41_current	0	R/W	Defines current into Current sink CURR41	
				00h	0 mA
				01h	0.15 mA
			
				FFh	38.25 mA

Table 49. *Curr42 current Register*

Addr: 14h		Curr42 current			
This register controls the curr42 current sink current.					
Bit	Bit Name	Default	Access	Description	
7:0	curr42_current	0	R/W	Defines current into Current sink CURR42	
				00h	0 mA
				01h	0.15 mA
			
				FFh	38.25 mA

Table 50. Curr43 current Register

Addr: 15h		Curr43 current			
This register controls the curr43 current sink current.					
Bit	Bit Name	Default	Access	Description	
7:0	curr43_current	0	R/W	Defines current into Current sink CURR43	
				00h	0 mA
				01h	0.15 mA
			
				FFh	38.25 mA

8.4.5 LED Pattern Generator

The LED pattern generator is capable of producing a pattern with 32 bits length and 1 second duration (31.25ms for each bit). The pattern itself can be started every second, every 2nd, 3rd up to 7th second¹.

With this pattern all current sinks can be controlled. The pattern itself switches the configured current sources between 0 and their programmed current.

If everything else is switched off, the current consumption in this mode is IACTIVE. (excluding current through switched on current source) and the charge pump, if required. The charge pump can be automatically switched on/off depending on the pattern (set register cp_auto_on on page 20=1) to reduce the overall current consumption.

Figure 16. LED Pattern Generator AS3675 for pattern_color = 0

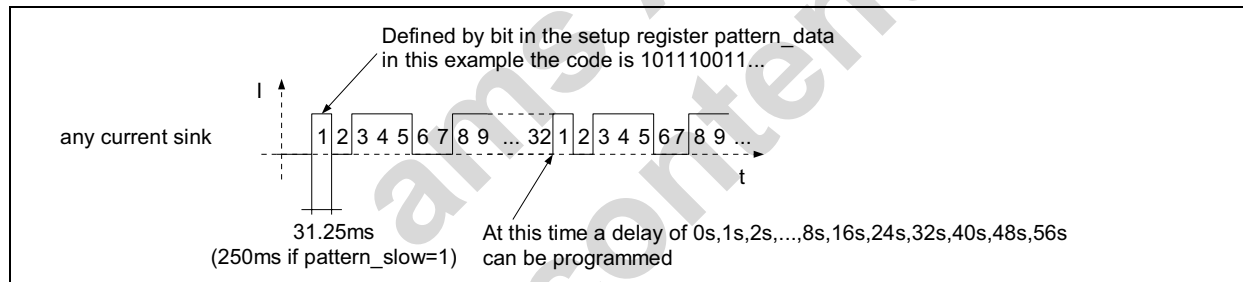

To select the different current sinks to be controlled by the LED pattern generator, see the 'xxxx'_mode registers (where 'xxxx' stands for the to be controlled current sink, e.g. curr1_mode for CURR1 current sink). See also the description of the different current sinks.

To allow the generator of a color patterns set the bit pattern_color to '1'. Then the pattern can be connected to CURRx as follows:

Figure 17. LED Pattern Generator AS3675 for pattern_color = 1

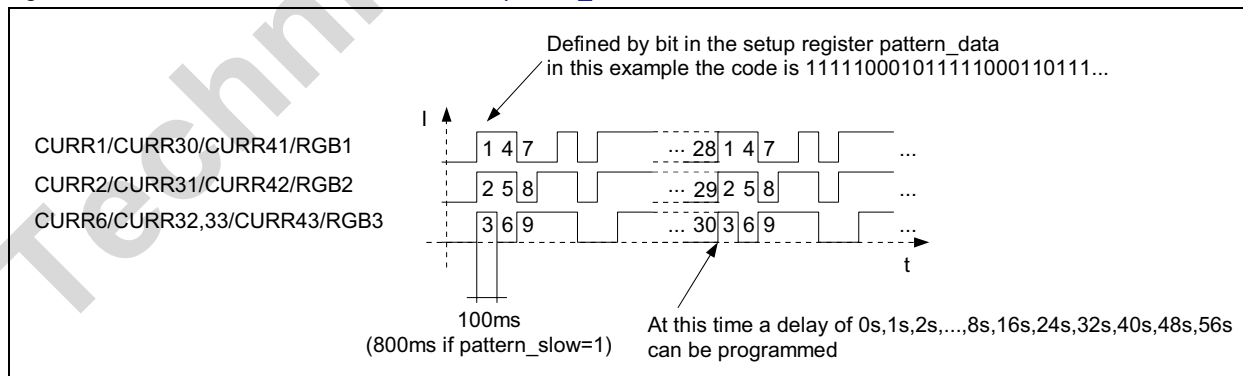

1. All times can be extended by a factor of 8 by setting pattern_slow=1 (this result in a delay of up to 56s)

Only those current sinks will be controlled, where the 'xxxx'_mode register is configured for LED pattern.

If the register bit `pattern_slow` is set, all pattern times are increased by a factor of eight. (bit duration: 250ms if `pattern_color=0` / 800ms if `pattern_color=1`, delays between pattern up to 56s).

Soft Dimming for Pattern

The internal pattern generator can be combined with the internal pwm dimming modulator to obtain as shown in the following figure:

Figure 18. Soft dimming Architecture for the AS3675 (`softdim_pattern=1` and `pattern_color = 1`)

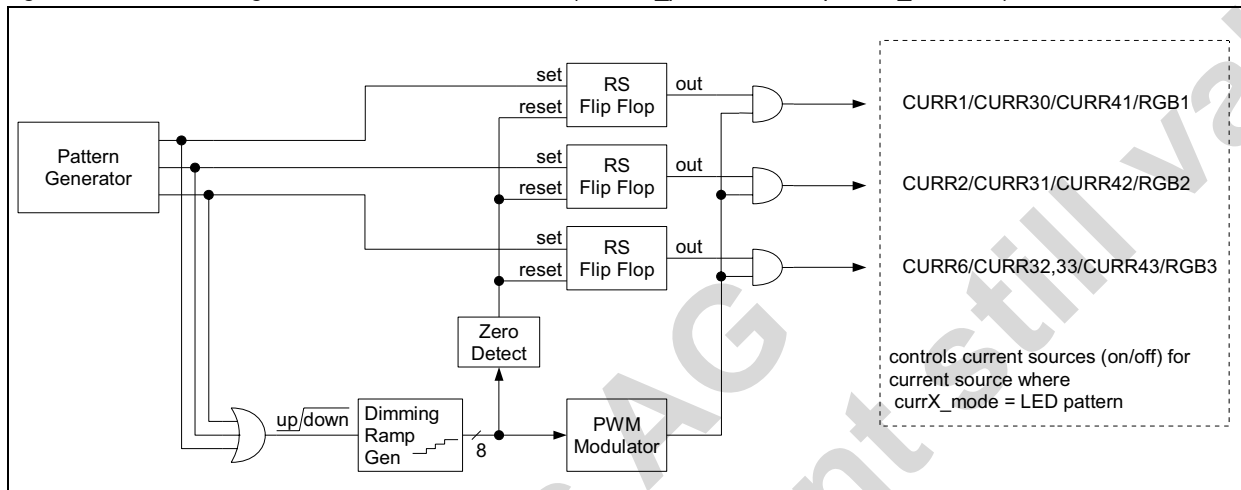

With the AS3675 smooth fade-in and fade-out effects can be automatically generated.

As there is only one dimming ramp generator and one pwm modulator following constraints have to be considered when setting up the pattern (applies only if `pattern_color=1`):

Figure 19. Soft dimming example Waveform for CURRE30-32

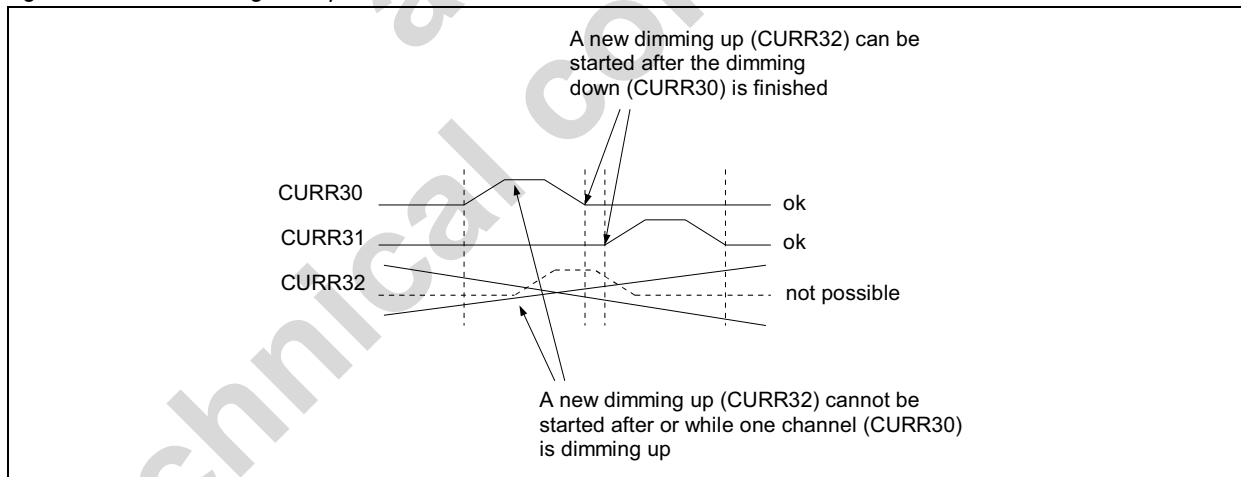

However using the identical dimming waveform for two channels is possible as shown in the following figure:

Figure 20. Soft dimming example Waveform for CURR30-32

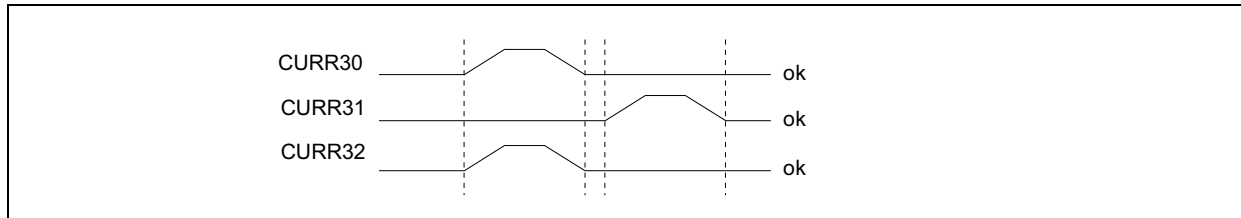

LED Pattern Registers

Table 51. Pattern data0...Pattern data3 Registers

Addr: 19h,1Ah,1Bh,1Ch		Pattern data0, Pattern data1, Pattern data2, Pattern data3		
This registers contains the pattern data for the current sinks.				
Bit	Bit Name	Default	Access	Description
7:0	pattern_data[7:0] ¹	0	R/W	Pattern data0
7:0	pattern_data[15:8]1111 ¹	0	R/W	Pattern data1
7:0	pattern_data[23:16]1111 ¹	0	R/W	Pattern data2
7:0	pattern_data[31:24]1111 ¹	0	R/W	Pattern data3

- Update any of the pattern register only if none of the current sources is connected to the pattern generator ('xxxx'_mode must not be 11b). The pattern generator is automatically started at the same time when any of the current sources is connected to the pattern generator

Table 52. Pattern control Register

Addr: 18h		Pattern control			
This register controls the LED pattern					
Bit	Bit Name	Default	Access	Description	
0	pattern_color	0	R/W	Defines the pattern type for the current sinks	
				0b	single 32 bit pattern (also set currX_mode = 11)
				1b	RGB pattern with each 10 bits (set all currX_mode = 11)
2:1	pattern_delay	00b	R/W	Delay between pattern, details (see Table 55); together with pattern_delay2 sets the delay time between patterns	
3	softdim_pattern ¹	0b	R/W	Enable the 'soft' dimming feature for the pattern generator	
				0	Pattern generator directly control current sources
				1	'Soft Dimming' is performed (see page 37)

- If softdim_pattern=1, don't set curr30_mode, curr31_mode, curr32_mode or curr33_mode to 11b.

Table 53. gpio current Register

Addr: 2Ch		gpio current		
Bit	Bit Name	Default	Access	Description
4	pattern_delay2	0	R/W	Delay between pattern (see Table 55 on page 39); together with pattern_delay sets the delay time between patterns

Table 53. *gpio current* Register (Continued)

Addr: 2Ch		gpio current			
Bit	Bit Name	Default	Access	Description	
6	pattern_slow	0	R/W	Pattern timing control	
				0b	normal mode
				1b	slow mode (all pattern times are increased by a factor of eight)

Table 54. *Pattern End* Register

Addr: 54h		Pattern End			
Bit	Bit Name	Default	Access	Description	
0	pattern_end	0	R	pattern_end is toggled from 0 to 1 (or from 1 to 0) at each end of the pattern just before restarting of the internal pattern generator at the first bit of the pattern data (can be used to synchronize the baseband software to the pattern generator) ¹	

1. pattern_end toggles whenever the AS3675 is in active mode (see [Section 8.12 Operating Modes](#) on page 71) even if no pattern data has been setup.

Table 55. *LED Pattern timing*

pattern_slow	pattern_delay2	pattern_delay[1..0]	bit duration [ms]		delay [s] between patterns	pattern duration [s] (total cycle time: pattern + delay)
	delay between patterns		pattern_color=0	pattern_color=1		
0	0	00	31	100	0 ¹	1
0	0	01	31	100	1	2
0	0	10	31	100	2	3
0	0	11	31	100	3	4
0	1	00	31	100	4	5
0	1	01	31	100	5	6
0	1	10	31	100	6	7
0	1	11	31	100	7	8
1	0	00	250	800	0	8
1	0	01	250	800	8	16
1	0	10	250	800	16	24
1	0	11	250	800	24	32
1	1	00	250	800	32	40
1	1	01	250	800	40	48
1	1	10	250	800	48	56
1	1	11	250	800	56	64

1. Even by setting 000 for pattern delay, there is a small delay before the new patterns starts.

8.4.6 PWM Generator

The PWM generator can be used for any current sink. The setting applies for all current sinks, which are controlled by the pwm generator (e.g. CURR1 is pwm controlled if `curr1_mode = 10`). The pwm modulated signal can switch on/off the current sinks and therefore depending on its duty cycle change the brightness of an attached LED.

Internal PWM Generator

The internal PWM generator uses the 2MHz internal clock as input frequency and its dimming range is 6 bits digital ($2\text{MHz} / 2^6 = 31.3\text{kHz}$ pwm frequency) and 2 bits analog. Depending on the actual code in the register `pwm_code` the following algorithm is used:

If `pwm_code` bit 7 = 1

Then the upper 6 bits (Bits 7:2) of `pwm_code` are used for the 6 bits PWM generation, which controls the selected current sinks directly

If `pwm_code` bit 7 = 0 and bit 6 = 1

Then bits 6:1 of `pwm_code` are used for the 6 bits PWM generation. This signal controls the selected current sinks, but the analog current of these sinks is divided by 2

If `pwm_code` bit 7 and bit 6 = 0

Then bits 5:0 of `pwm_code` are used for the 6 bits PWM generation. This signal controls the selected current sinks, but the analog current of these sinks is divided by 4

Figure 21. PWM Control

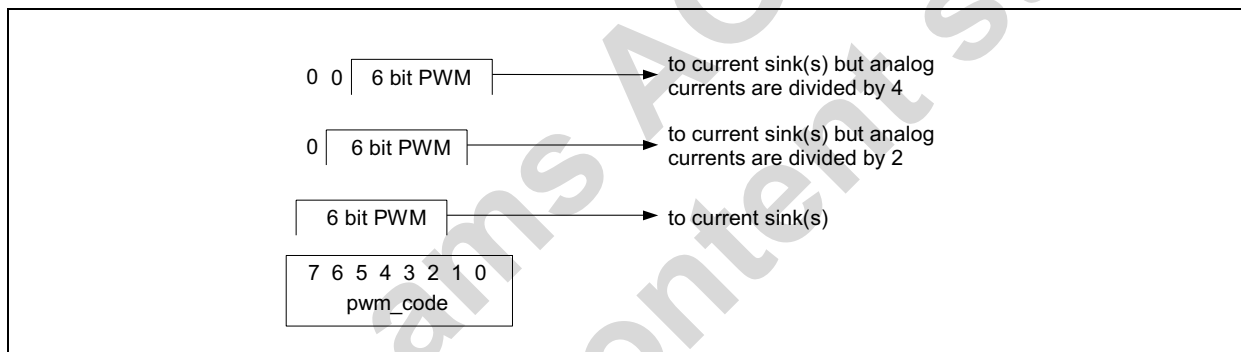

Automatic Up/Down Dimming

If the register `pwm_dim_mode` is set to 01 (up dimming) or 10 (down dimming) the value within the register `pwm_code` is increased (up dimming) or decreased (down dimming) every time and amount (either $1/4^{\text{th}}$ or $1/8^{\text{th}}$) defined by the register `pwm_dim_speed`. The maximum value of 255 (completely on) and the minimum value of 0 (off) is never exceeded. It is used to smoothly and automatically dim the brightness of the LEDs connected to any of the current sinks. The PWM code is readable all the time (also during up and down dimming).

The waveform for up dimming looks as follows (cycles omitted for simplicity):

Figure 22. PWM Dimming Waveform for up dimming (`pwm_dim_mode = 01`); `currX_mode = PWM controlled` (not all steps shown)

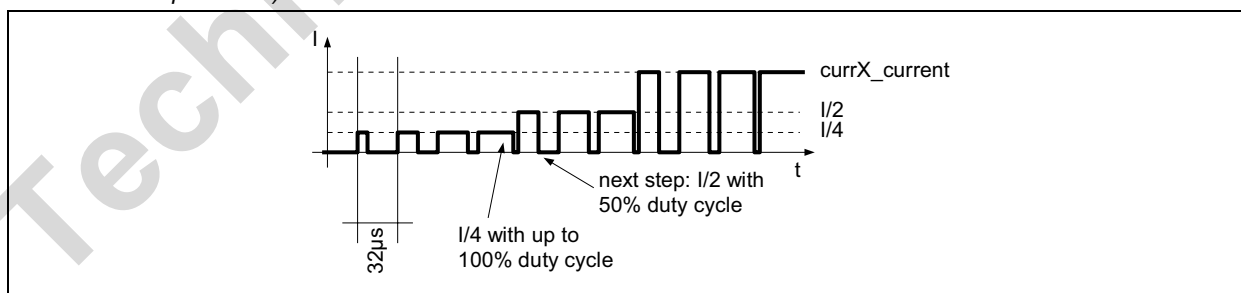

The internal pwm modulator circuit controls the current sinks as shown in the following figure:

Figure 23. PWM Control Circuit ($\text{currX_mode} = 10\text{b}$ (PWM controlled)); $X = \text{any current sink}$

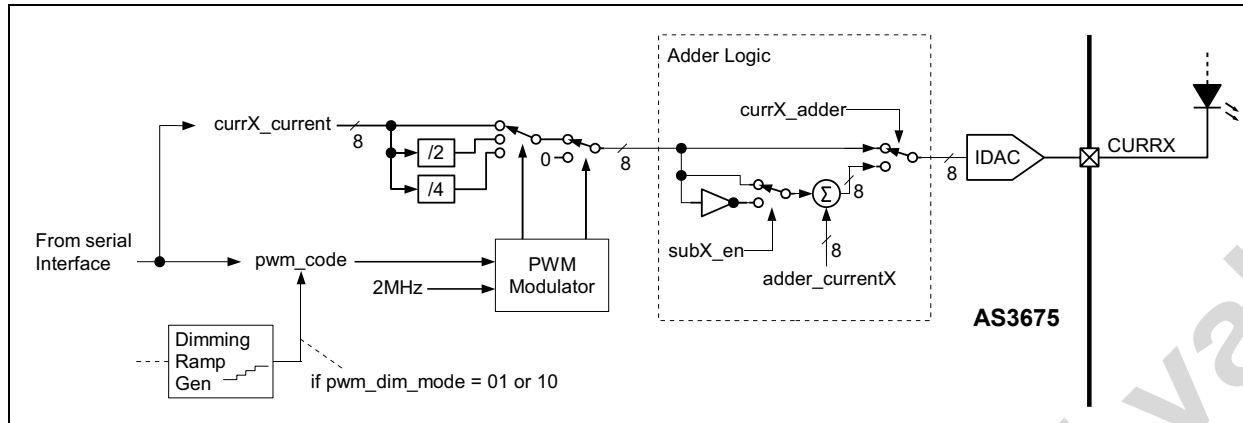

The adder logic (available for all current sinks) is intended to allow dimming not only from 0% to 100% (or 100% to 0%) of currX_current , but also e.g. from 10% to 110% (or 110% to 10%) of currX_current . The starting current for up dimming is defined by $0 + \text{currX_adder}$ and the end current is defined by $\text{currX_current} + \text{currX_adder}$.

An overflow of the internal bus (8 Bits wide to the IDAC) has to be avoided by the register settings ($\text{currX_current} + \text{currX_adder}$ must not exceed 255).

If the register subX_en is set, the result from the pwm modulator is inverted logically. That means for up dimming the starting current is defined by $\text{currX_adder} - 1$ and the end current is defined by $\text{currX_adder} - \text{currX_current} - 1$. An overflow of the internal bus (8 Bits wide to the IDAC) has to be avoided by the register settings ($\text{currX_adder} - \text{currX_current} - 1$ must not be below zero).

Its purpose is to dim one channel e.g. CURR30 from e.g. 110% to 10% of curr30_current and at the same time dim another channel e.g. CURR31 from 20% to 120% of curr31_current .

Note: The adder logic operates independent of the currX_mode setting, but its main purpose is to work together with the pwm modulator (improved up/down dimming)

If the adder logic is not used anymore, set the bit currX_adder to 0. (Setting adder_currentX to 0 is not sufficient)

At the end of up/down dimming, the pwm_code register keeps its final value (for up-dimming 255 and for down-dimming 0). This can be used to identify the exact time, when up/down dimming is finished.

Table 56. PWM Dimming Table

Step	Decrease by 1/4th every step		Decrease by 1/8th every step		Seconds	Seconds	Seconds	Seconds
	%Dimming	PWM	%Dimming	PWM	50msec/Step	25msec/Step	5msec/Step	2.5msec/Step
1	100,0	255	100,0	255	0,00s	0,00s	0,000s	0,000s
2	75,3	192	87,8	224	0,05s	0,03s	0,005s	0,003s
3	56,5	144	76,9	196	0,10s	0,05s	0,010s	0,005s
4	42,4	108	67,5	172	0,15s	0,08s	0,015s	0,008s
5	31,8	81	59,2	151	0,20s	0,10s	0,020s	0,010s
6	23,9	61	52,2	133	0,25s	0,13s	0,025s	0,013s
7	18,0	46	45,9	117	0,30s	0,15s	0,030s	0,015s
8	13,7	35	40,4	103	0,35s	0,18s	0,035s	0,018s
9	10,6	27	35,7	91	0,40s	0,20s	0,040s	0,020s
10	8,2	21	31,4	80	0,45s	0,23s	0,045s	0,023s
11	6,3	16	27,5	70	0,50s	0,25s	0,050s	0,025s

Table 56. PWM Dimming Table

Step	Decrease by 1/4th every step		Decrease by 1/8th every step		Seconds	Seconds	Seconds	Seconds
	%Dimming	PWM	%Dimming	PWM	50msec/Step	25msec/Step	5msec/Step	2.5msec/Step
12	4,7	12	24,3	62	0,55s	0,28s	0,055s	0,028s
13	3,5	9	21,6	55	0,60s	0,30s	0,060s	0,030s
14	2,7	7	19,2	49	0,65s	0,33s	0,065s	0,033s
15	2,4	6	16,9	43	0,70s	0,35s	0,070s	0,035s
16	2,0	5	14,9	38	0,75s	0,38s	0,075s	0,038s
17	1,6	4	13,3	34	0,80s	0,40s	0,080s	0,040s
18	1,2	3	11,8	30	0,85s	0,43s	0,085s	0,043s
19	0,8	2	10,6	27	0,90s	0,45s	0,090s	0,045s
20	0,4	1	9,4	24	0,95s	0,48s	0,095s	0,048s
21	0,0	0	8,2	21	1,00s	0,50s	0,100s	0,050s
22			7,5	19	1,05s	0,53s	0,105s	0,053s
23			6,7	17	1,10s	0,55s	0,110s	0,055s
24			5,9	15	1,15s	0,58s	0,115s	0,058s
25			5,5	14	1,20s	0,60s	0,120s	0,060s
26			5,1	13	1,25s	0,63s	0,125s	0,063s
27			4,7	12	1,30s	0,65s	0,130s	0,065s
28			4,3	11	1,35s	0,68s	0,135s	0,068s
29			3,9	10	1,40s	0,70s	0,140s	0,070s
30			3,5	9	1,45s	0,73s	0,145s	0,073s
31			3,1	8	1,50s	0,75s	0,150s	0,075s
32			2,7	7	1,55s	0,78s	0,155s	0,078s
33			2,4	6	1,60s	0,80s	0,160s	0,080s
34			2,0	5	1,65s	0,83s	0,165s	0,083s
35			1,6	4	1,70s	0,85s	0,170s	0,085s
36			1,2	3	1,75s	0,88s	0,175s	0,088s
37			0,8	2	1,80s	0,90s	0,180s	0,090s
38			0,4	1	1,85s	0,93s	0,185s	0,093s
39			0,0	0	1,90s	0,95s	0,190s	0,095s

PWM Generator Registers

Table 57. Pwm control Register

Addr: 16h		Pwm control			
This register controls PWM generator					
Bit	Bit Name	Default	Access	Description	
2:1	pwm_dim_mode	00b	R/W	Selects the dimming mode	
				00b	no dimming; actual content of register <code>pwm_code</code> is used for pwm generator
				01b	logarithmic up dimming (codes are increased). Start value is actual <code>pwm_code</code>
				10b	logarithmic down dimming (codes are decreased). Start value is actual <code>pwm_code</code> ; switch off the dimmed current source after dimming is finished to avoid unnecessary quiescent current
				11b	NA
5:3	pwm_dim_speed	000b	R/W	Defines dimming speed by increase/decrease <code>pwm_code</code>	
				000b	by 1/4 th every 50 msec (total dim time 1.0s)
				001b	by 1/8 th every 50 msec (total dim time 1.9s)
				010b	by 1/4 th every 25 msec (total dim time 0.5s)
				011b	by 1/8 th every 25 msec (total dim time 0.95s)
				100b	by 1/4 th every 5 msec (total dim time 100ms)
				101b	by 1/8 th every 5 msec (total dim time 190ms)
				110b	by 1/4 th every 2.5 msec (total dim time 50ms)
				111b	by 1/8 th every 2.5 msec (total dim time 95ms)

Table 58. pwm code Register

Addr: 17h		pwm code			
This register controls the Pwm code.					
Bit	Bit Name	Default	Access	Description	
7:0	pwm_code	00b	R/W	Selects the PWM code	
				00h	0% duty cycle
				FFh	100% duty cycle
			

Table 59. Adder Current 1 Register

Addr: 30h		Adder Current 1			
		This register defines the current which can be added to CURR1, CURR30, CURR41, RGB1			
Bit	Bit Name	Default	Access	Description	
7:0	adder_current1	00b	R/W	Selects the added current value – do not exceed together with currX_current the internal 8 Bit range (see text)	
				00h	0 (represents 0mA)
			
				FFh	255 (represents 38.25mA)

Table 60. Adder Current 2 Register

Addr: 31h		Adder Current 2			
		This register defines the current which can be added to CURR2, CURR31, CURR42, RGB2			
Bit	Bit Name	Default	Access	Description	
7:0	adder_current2	00b	R/W	Selects the added current value – do not exceed together with currX_current the internal 8 Bit range (see text)	
				00h	0 (represents 0mA)
			
				FFh	255 (represents 38.25mA)

Table 61. Adder Current 3 Register

Addr: 32h		Adder Current 3			
		This register defines the current which can be added to CURR6, CURR32, CURR43, RGB3			
Bit	Bit Name	Default	Access	Description	
7:0	adder_current3	00b	R/W	Selects the added current value – do not exceed together with currX_current the internal 8 Bit range (see text)	
				00h	0 (represents 0mA)
			
				FFh	255 (represents 38.25mA)

Table 62. Adder Current 4 Register

Addr: 52h		Adder Current 4			
		This register defines the current which can be added to CURR33			
Bit	Bit Name	Default	Access	Description	
7:0	adder_current4	00b	R/W	Selects the added current value – do not exceed together with currX_current the internal 8 Bit range (see text)	
				00h	0 (represents 0mA)
			
				FFh	255 (represents 38.25mA)

Table 63. Adder Enable 1 Register

Addr: 33h		Adder Enable 1			
		Enables the adder circuit for the selected current sources			
Bit	Bit Name	Default	Access	Description	
0	rgb1_adder	0	R/W	Enables adder circuit for current source RGB1	
				0	Normal Operation of the current source
				1	adder_current1 gets added to the current source current
1	rgb2_adder	0	R/W	Enables adder circuit for current source RGB2	
				0	Normal Operation of the current source
				1	adder_current2 gets added to the current source current
2	rgb3_adder	0	R/W	Enables adder circuit for current source RGB3	
				0	Normal Operation of the current source
				1	adder_current3 gets added to the current source current
3	curr41_adder	0	R/W	Enables adder circuit for current source CURR41	
				0	Normal Operation of the current source
				1	adder_current1 gets added to the current source current
4	curr42_adder	0	R/W	Enables adder circuit for current source CURR42	
				0	Normal Operation of the current source
				1	adder_current2 gets added to the current source current
5	curr43_adder	0	R/W	Enables adder circuit for current source CURR43	
					Normal Operation of the current source
					adder_current3 gets added to the current source current

Table 64. Adder Enable 2 Register

Addr: 34h		Adder Enable 2			
		Enables the adder circuit for the selected current sources			
Bit	Bit Name	Default	Access	Description	
0	curr1_adder	0	R/W	Enables adder circuit for current source CURR1	
				0	Normal Operation of the current source
				1	adder_current1 gets added to the current source current
1	curr2_adder	0	R/W	Enables adder circuit for current source CURR2	
				0	Normal Operation of the current source
				1	adder_current2 gets added to the current source current
2	curr6_adder	0	R/W	Enables adder circuit for current source CURR6	
				0	Normal Operation of the current source
				1	adder_current3 gets added to the current source current

Table 64. Adder Enable 2 Register (Continued)

Addr: 34h		Adder Enable 2			
Enables the adder circuit for the selected current sources					
Bit	Bit Name	Default	Access	Description	
3	curr30_adder	0	R/W	Enables adder circuit for current source CURR30	
				0	Normal Operation of the current source
				1	adder_current1 gets added to the current source current
4	curr31_adder	0	R/W	Enables adder circuit for current source CURR31	
				0	Normal Operation of the current source
				1	adder_current2 gets added to the current source current
5	curr32_adder	0	R/W	Enables adder circuit for current source CURR32	
				0	Normal Operation of the current source
				1	adder_current3 gets added to the current source current
6	curr33_adder	0	R/W	Enables adder circuit for current source CURR33	
				0	Normal Operation of the current source
				1	adder_current4 gets added to the current source current

Table 65. Subtract Enable Register

Addr: 35h		Subtract Enable			
Enable the inversion from the signal from the pwm generator					
Bit	Bit Name	Default	Access	Description	
0	sub_en1	0	R/W	Inverts the signal from the pwm generator	
				0	Direct Operation (no inversion)
				1	The signal from the pwm generator for which the adder is enabled (curr1_adder = 1, curr30_adder = 1, rgb1_adder = 1, curr41_adder = 1) is inverted
1	sub_en2	0	R/W	Inverts the signal from the pwm generator	
				0	Direct Operation (no inversion)
				1	The signal from the pwm generator for which the adder is enabled (curr2_adder = 1, curr31_adder = 1, rgb2_adder = 1, curr42_adder = 1) is inverted
2	sub_en3	0	R/W	Inverts the signal from the pwm generator	
				0	Direct Operation (no inversion)
				1	The signal from the pwm generator for which the adder is enabled (curr6_adder = 1, curr32_adder = 1, rgb3_adder = 1, curr43_adder = 1) is inverted

Table 65. Subtract Enable Register (Continued)

Addr: 35h		Subtract Enable			
		Enable the inversion from the signal from the pwm generator			
Bit	Bit Name	Default	Access	Description	
3	sub_en4	0	R/W	Inverts the signal from the pwm generator	
				0	Direct Operation (no inversion)
				1	The signal from the pwm generator for which the adder is enabled (<code>curr33_adder = 1</code>) is inverted

8.5 General Purpose Input / Output

The GPIO is a highly-configurable general purpose input/output pin which can be used for the following functionality:

- Digital Schmitt Trigger Input
- Digital Output with 4mA Driving Capability at 2.8V Supply (VANA)
- Tristate Output
- Analog Input to the ADC
- Default Mode for GPIO and VANA/GPI is Input (Pull-Down)

Table 66. GPIO Pin Function Summary

GPIO Pin	Configuration	Additional Function
GPIO	Digital Input, Totem-Pole Output (Push/Pull), Open Drain (PMOS or NMOS), High-Z, Pull-Down or Pull-Up Resistor	ADC Input
VANA/GPI	Digital Input	ADC Input, LDO output

Figure 24. GPIO and VANA/GPI Blockdiagram

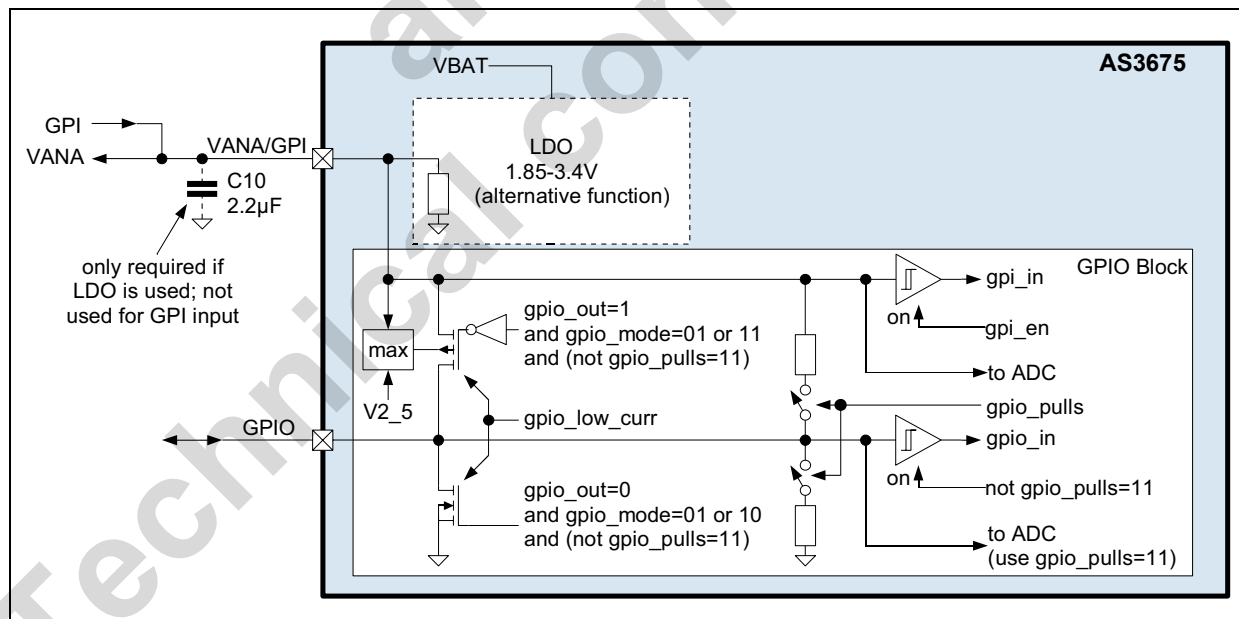

8.5.1 Unused GPIO Pin

If the pin GPIO is not used, they can be left open (an internal pulldown, which is enabled by default, will pull them to GND).

8.5.2 GPIO Characteristics

Table 67. GPIO DC Characteristics

Symbol	Parameter	Condition	Min	Typ	Max	Unit
Rpull	Pull up/Pull down Resistance	enabled by <code>gpio_pulls</code>	30		75	kΩ
VGPIO	Supply Voltage	=VANA/GPI	1.5		3.4	V
V _{IH}	High Level Input Voltage		0.7·VANA min. 1.75V			V
V _{IL}	Low Level Input Voltage				0.3· VANA min. 0.75V	V
V _{HYS}	Hysteresis		0.1· VANA min. 250mV			V
I _{LEAK}	Input Leakage Current	To V2_5 or VANA/GPI and VSS	-5		5	μA
V _{OH}	High Level Output Voltage	at I _{OUT}	0.8·VANA			V
V _{OL}	Low Level Output Voltage	at I _{OUT}			0.2· VANA	V
I _{OUT}	Driving Capability	VANA/GPI = 2.8V, <code>gpio_low_curr</code> = 1	4			mA
		VANA/GPI = 2.8V, <code>gpio_low_curr</code> = 0	16			
CLOAD	Capacitive Load				50	pF

8.5.3 GPIO Registers

Table 68. GPIO output 1 Register

Addr: 05h		GPIO output 1			
This register controls GPIO outputs.					
Bit	Bit Name	Default	Access	Description	
0	gpi_curr1_en	0	R/W	Enables the CURR1 input	
				0	input disabled
				1	input enabled
1	gpi_curr2_en	0	R/W	Enables the CURR2 input	
				0	input disabled
				1	input enabled
2	gpi_curr6_en	0	R/W	Enables the CURR6 input	
				0	input disabled
				1	input enabled
3				not used	
4	gpi_curr30_en	0	R/W	Enables the CURR30 input	
				0	input disabled
				1	input enabled

Table 68. GPIO output 1 Register (Continued)

Addr: 05h		GPIO output 1			
This register controls GPIO outputs.					
Bit	Bit Name	Default	Access	Description	
5	gpi_curr31_en	0	R/W	Enables the CURR31 input	
				0	input disabled
				1	input enabled
6	gpi_curr32_en	0	R/W	Enables the CURR32 input	
				0	input disabled
				1	input enabled
7	gpi_curr33_en	0	R/W	Enables the CURR33 input	
				0	input disabled
				1	input enabled

Table 69. GPIO signal 1 Register

Addr: 06h		GPIO signal 1		
This register controls GPIO outputs.				
Bit	Bit Name	Default	Access	Description
0	gpi_curr1_in	N/A	R	Reads a logic signal from pin CURR1; if gpi_curr1_en=1
1	gpi_curr2_in	N/A	R	Reads a logic signal from pin CURR2; if gpi_curr2_en=1
2	gpi_curr6_in	N/A	R	Reads a logic signal from pin CURR6; if gpi_curr6_en=1
3		N/A		not used
4	gpi_curr30_in	N/A	R	Reads a logic signal from pin CURR30; if gpi_curr30_en=1
5	gpi_curr31_in	N/A	R	Reads a logic signal from pin CURR31; if gpi_curr31_en=1
6	gpi_curr32_in	N/A	R	Reads a logic signal from pin CURR32; if gpi_curr32_en=1
7	gpi_curr33_in	N/A	R	Reads a logic signal from pin CURR33; if gpi_curr33_en=1

Table 70. GPIO output 2 Register

Addr: 50h		GPIO output 2			
This register controls GPIO outputs.					
Bit	Bit Name	Default	Access	Description	
0	gpio_out	0	R/W	Writes a logic signal to pin GPIO; this is independent of any other bit setting e.g., gpio_mode Table 72.	
1	gpi_en	0	R/W	Enables the VANA/GPI input	
				0	input disabled
				1	input enabled
2	gpi_rgb1_en	0	R/W	Enables the RGB1 input	
				0	input disabled
				1	input enabled
3	gpi_rgb2_en	0	R/W	Enables the RGB2 input	
				0	input disabled
				1	input enabled

Table 70. GPIO output 2 Register (Continued)

Addr: 50h		GPIO output 2			
This register controls GPIO outputs.					
Bit	Bit Name	Default	Access	Description	
4	gpi_rgb3_en	0	R/W	Enables the RGB3 input	
				0	input disabled
				1	input enabled
5	gpi_curr41_en	0	R/W	Enables the CURR41 input	
				0	input disabled
				1	input enabled
6	gpi_curr42_en	0	R/W	Enables the CURR42 input	
				0	input disabled
				1	input enabled
7	gpi_curr43_en	0	R/W	Enables the CURR43 input	
				0	input disabled
				1	input enabled

Table 71. GPIO signal 2 Register

Addr: 51h		GPIO signal 2		
This register controls GPIO outputs.				
Bit	Bit Name	Default	Access	Description
0	gpio_in	N/A	R	Reads a logic signal from pin GPIO; this is independent of any other setting e.g., Table 72 except gpio_pulls=11
1	gpi_in	N/A	R	Reads a logic signal from pin VANA/GPI; if gpi_en=1
2	gpi_rgb1_in	N/A	R	Reads a logic signal from pin RGB1; if gpi_rgb1_en=1
3	gpi_rgb2_in	N/A	R	Reads a logic signal from pin RGB2; if gpi_rgb2_en=1
4	gpi_rgb3_in	N/A	R	Reads a logic signal from pin RGB3; if gpi_rgb3_en=1
5	gpi_curr41_in	N/A	R	Reads a logic signal from pin CURR41; if gpi_curr41_en=1
6	gpi_curr42_in	N/A	R	Reads a logic signal from pin CURR42; if gpi_curr42_en=1
7	gpi_curr43_in	N/A	R	Reads a logic signal from pin CURR43; if gpi_curr43_en=1

Table 72. GPIO control Register

Addr: 1Eh		GPIO control			
This register controls GPIO and GPIO1 pin functions.					
Bit	Bit Name	Default	Access	Description	
1:0	gpio_mode	00	R/W	Defines the direction for pin GPIO	
				00	Input only
				01	Output (push and pull)
				10	Output (open drain, only push; only NMOS is active)
				11	Output (open drain, only pull; only PMOS is active)

Table 72. GPIO control Register (Continued)

Addr: 1Eh		GPIO control			
This register controls GPIO and GPIO1 pin functions.					
Bit	Bit Name	Default	Access	Description	
3:2	gpio_pulls	01	R/W	Adds the following pullup/pulldown to pin GPIO; this is independent of setting of bits <code>gpio_mode</code>	
				00	None
				01	Pulldown
				10	Pullup
				11	ADC input (<code>gpio_mode = XX</code>); recommended for analog signals

Table 73. GPIO driving cap Register

Addr: 20h		GPIO driving cap			
This register enables low current mode for GPIOs.					
Bit	Bit Name	Default	Access	Description	
0	gpio_low_curr	0	R/W	Defines the driving capability of pin GPIO	
				0	Iout
				1	Iout /4

8.6 LED Test

Figure 25. LED Function Testing

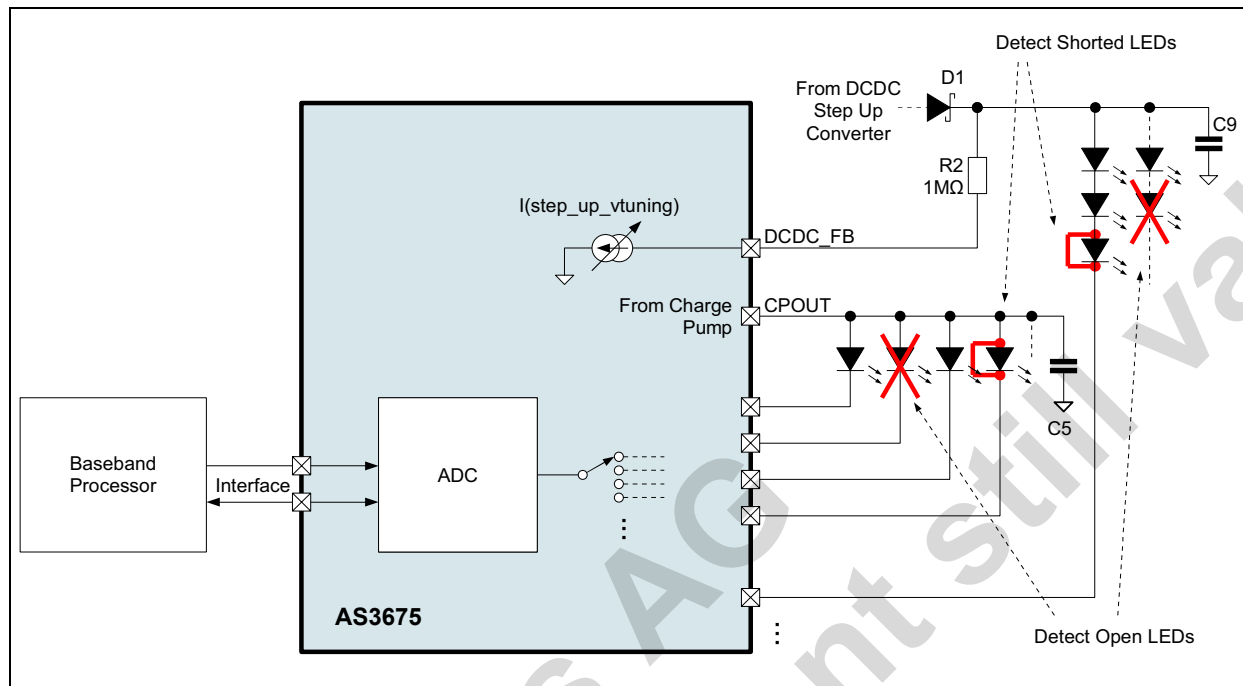

The AS3675 supports the verification of the functionality of all the connected LEDs (open and shorted LEDs can be detected). This feature is especially useful in production test to verify the correct assembly of the LEDs, all its connectors and cables. It can also be used in the field to verify if any of the LEDs is damaged. A damaged LED can then be disabled (to avoid unnecessary currents).

The current sources, charge pump, dc/dc converter and the internal ADC are used to verify the forward voltage of the LEDs. If this forward voltage is within the specified limits of the LEDs, the external circuitry is assumed to operate.

8.6.1 Function Testing for single LEDs connected to the Charge Pump

For any current source connected to the charge pump (CURR30-33) where only one LED is connected between the charge pump and the current sink (see Figure 1) use:

Table 74. Function Testing for LEDs connected to the Charge Pump

Step	Action	Example Code
1	Switch on the charge pump and set it into manual 1:2 mode (to avoid automatic mode switching during measurements)	Reg 23h ≤ 14h (<code>cp_mode</code> = 1:2, manual) Reg 00h ≤ 04h (<code>cp_on</code> = 1)
2	Switch on the current sink for the LED to be tested	e.g. for register CURR31 set to 9mA use Reg 10h ≤ 0Fh (<code>curr3x_other</code> = 9mA) Reg 03h ≤ 0ch (<code>curr31_mode</code> = <code>curr31_other</code>)
3	Measure with the ADC the voltage on CPOUT	Reg 26h ≤ 95h (<code>adc_select</code> =CPOUT, start ADC) Fetch the ADC result from Reg 27h and 28h
4	Measure with the ADC the voltage on the switched on current sink	Reg 26h ≤ 8bh (<code>adc_select</code> =CURR31, start ADC) Fetch the ADC result from Reg 27h and 28h
5	Switch off the current sink for the LED to be tested	Reg 03h ≤ 00h (<code>curr31_mode</code> = off)
6	Compare the difference between the ADC measurements (which is the actual voltage across the tested LED) against the specification limits of the tested LED	Calculation performed in baseband uProcessor

Table 74. Function Testing for LEDs connected to the Charge Pump

Step	Action	Example Code
7	Do the same procedure for the next LED starting from point 2	Jump to 2. If not all the LEDs have been tested
8	Switch off the charge pump set charge pump automatic mode	Reg 00h ≤ 00h (cp_on = 0) Reg 23h ≤ 00h

8.6.2 Function Testing for LEDs connected to the Step Up DCDC Converter

For LEDs connected to the DCDC converter (usually current sinks CURR1, CURR2 and CURR6) use the following procedure:

Table 75. Function Testing for LEDs connected to the DCDC converter

Step	Action	Example Code
1	Switch on the current sink for the LED string to be tested (CURR1,2 or 6)	e.g. Test LEDs on CURR1: Reg 01h ≤ 01h (curr1_mode=on) Reg 09h ≤ 3ch (curr1_current = 9mA)
2	Select the feedback path for the LED string to be tested (e.g. step_up_fb = 01 for LED string on CURR1)	Reg 21h ≤ 02h (step_up_fb=curr1)
3	Set the current for step_up_vtuning exactly above the maximum forward voltage of the tested LED string + 0.6V (for the current sink) + 0.25V; add 6% margin (accuracy of step_up_vtuning); this sets the maximum output voltage limit for the DCDC converter	e.g. 4 LEDs with UfMAX = 4.1V gives 17.25V +6% = 18.29V; if R2=1MΩ and R3 = open, then select step_up_vtuning = 18 (Reg 21h ≤ 92h; results in 19.25V over voltage protection voltage – Table 9 on page 14)
4	Set step_up_prot = 1	Reg 22h ≤ 04h
5	Switch on the DCDC converter	Reg 00h ≤ 08h
6	Wait 80ms (DCDC_FB settling time)	
7	Measure the voltage on DCDC_FB (ADC)	Reg 26h ≤ 96h (adc_select=DCDC_FB, start ADC; Fetch the ADC result from Reg 27h and 28h)
8	If the voltage on DCDC_FB is above 1.0V, the tested LED string is broken – then skip the following steps	(Code >199h)
9	Switch off the over voltage protection (step_up_prot =0)	Reg 22h ≤ 00h
10	Reduce step_up_vtuning step by step until the measured voltage on DCDC_FB (ADC) is above 1.0V. After changing step_up_vtuning always wait 80ms, before AD-conversion	e.g.: Reg 21h ≤ 62h (step_up_vtuning =12): ADC result=1,602V
11	Measure voltage on DCDC_FB	e.g. DCDC_FB=1.602V
12	Switch off the DCDC converter	Reg 00h ≤ 00h
13	The voltage on the LED string can be calculated now as follows (R4 = open): $V_{LEDSTRING} = V(DCDC_FB) + I(\text{step_up_vtuning}) * R2 - 0.5V$ (current sinks feedback voltage: VFB2). V(DCDC_FB) = ADC Measurement from point 11 I(step_up_vtuning) = last setting used for point 10	e.g.: $V_{LED} = (1.602V + 12V - 0.5V) / 4 = 3.276V$
14	Compare the calculated value against the specification limits of the tested LEDs	

Note: With the above described procedures electrically open and shorted LEDs can be automatically detected

8.7 Analog-to-Digital Converter

The AS3675 has a built-in 10-bit successive approximation analog-to-digital converter (ADC). It is internally supplied by V2_5, which is also the full-scale input range (0V defines the ADC zero-code). For input signals exceeding V2_5 (typ. 2.5V) a resistor divider with a gain of 0.4 (Ratioprescaler) is used to scale the input of the ADC converter. Consequently the resolution is:

Table 76. ADC Input Ranges, Compliances and Resolution

Channels (Pins)	Input Range	VLSB	Note
DCDC_FB, GPIO, AUDIO_IN, VANA/ GPI, audio controlled LED buffer output	0V-2.5V	2.44mV	V _{LSB} =2.5/1024
ADCTEMP_CODE	-30°C to 125°C	1 / ADCTC	junction temperature
CURR30-33, CURR4x, RGBx VBAT, CPOUT	0V-5.5V	6.1mV	V _{LSB} =2.5/1024 * 1/0.4; internal resistor divider used
CURR1, CURR2, CURR6	0V-1.0V	2.44mV	V _{LSB} =2.5/1024

Table 77. ADC Parameters

Symbol	Parameter	Condition	Min	Typ	Max	Unit
	Resolution		10			Bit
V _{IN}	Input Voltage Range	V _{SUPPLY} = V2_5	V _{SS}		see Table 76	V
DNL	Differential Non- Linearity			± 0.25		LSB
INL	Integral Non-Linearity			± 0.5		LSB
V _{OS}	Input Offset Voltage			± 0.25		LSB
R _{IN}	Input Impedance		100			MΩ
C _{IN}	Input Capacitance				9	pF
V _{SUPPLY} (V2_5)	Power Supply Range	± 2%, internally trimmed.		2.5		V
I _{DD}	Power Supply Current	During conversion only.		500		μ A
I _{DD}	Power Down Current			100		nA
T _{TOL}	Temperature Sensor Accuracy	@ 25 °C	-10		+10	°C
ADCTOFFSET	ADC temperature measurement offset value			375		°C
ADCTC	Code temperature coefficient	Temperature change per ADC LSB		1.293 9		°C/ Code
RatiOPRESCALE R	Ratio of Prescaler	For all low voltage current sinks, CPOUT and VBAT		0.4		
Transient Parameters (2.5V, 25 °C)						
T _c	Conversion Time	All signals are internally generated and triggered by <code>start_conversion</code>		27		μs
f _c	Clock Frequency			1.0		MHz
t _s	Settling Time of S&H			16		μs

The junction temperature (T_{JUNCTION}) can be calculated with the following formula (ADCTEMP_CODE is the adc conversion result for channel 04h selected by register `adc_select` = 000100b):

$$T_{JUNCTION} [^{\circ}\text{C}] = ADCTOFFSET - ADCTC \cdot ADCTEMP_CODE \quad (\text{EQ } 5)$$

ADC Registers

Table 78. *ADC_MSB result Register*

Addr: 27h		ADC_MSB result			
		Together with Register 27h, this register contains the results (MSB) of an ADC cycle.			
Bit	Bit Name	Default	Access	Description	
6:0	D9:D3	N/A	R	ADC results register.	
7	result_not_ready	N/A	R	Indicates end of ADC conversion cycle	
				0	Result is ready
				1	Conversion is running

Table 79. *ADC_LSB result Register*

Addr: 28h		ADC_LSB result		
		Together with Register 28h, this register contains the results (LSB) of an ADC cycle		
Bit	Bit Name	Default	Access	Description
2:0	D2:D0	N/A	R	ADC result register

Table 80. ADC_control Register

Addr: 26h		ADC_control			
This register input source selection and initialization of ADC					
Bit	Bit Name	Default	Access	Description	
Selects input source as ADC input					
5:0	adc_select ¹	03h	R/W	000000 (00h)	AUDIO_IN
				000001 (01h)	VANA/GPI
				000010 (02h)	GPIO
				000011 (03h)	audio controlled LED buffer output
				000100 (04h)	reserved
				000101 (05h)	RGB1
				000110 (06h)	RGB2
				000111 (07h)	RGB3
				001000 (08h)	CURR1
				001001 (09h)	CURR2
				001010 (0Ah)	CURR30
				001011 (0Bh)	CURR31
				001100 (0Ch)	CURR32
				001101 (0Dh)	CURR33
				001110 (0Eh)	CURR41
				001111 (0Fh)	CURR42
				010000 (10h)	CURR43
				010001 (11h)	reserved
				010010 (12h)	reserved
				010011 (13h)	CURR6
010100 (14h)	VBAT				
010101 (15h)	CPOUT				
010110 (16h)	DCDC_FB				
010111 (17h)	ADCTEMP_CODE (junction temperature)				
	011xxx, 1xxxxx	reserved			
6				NA	
7	start_conversion	N/A	W	Writing a 1 into this bit starts one ADC conversion cycle.	

1. See Table [Table 76](#) for ADC ranges and resultion.

Figure 26. ADC Circuit

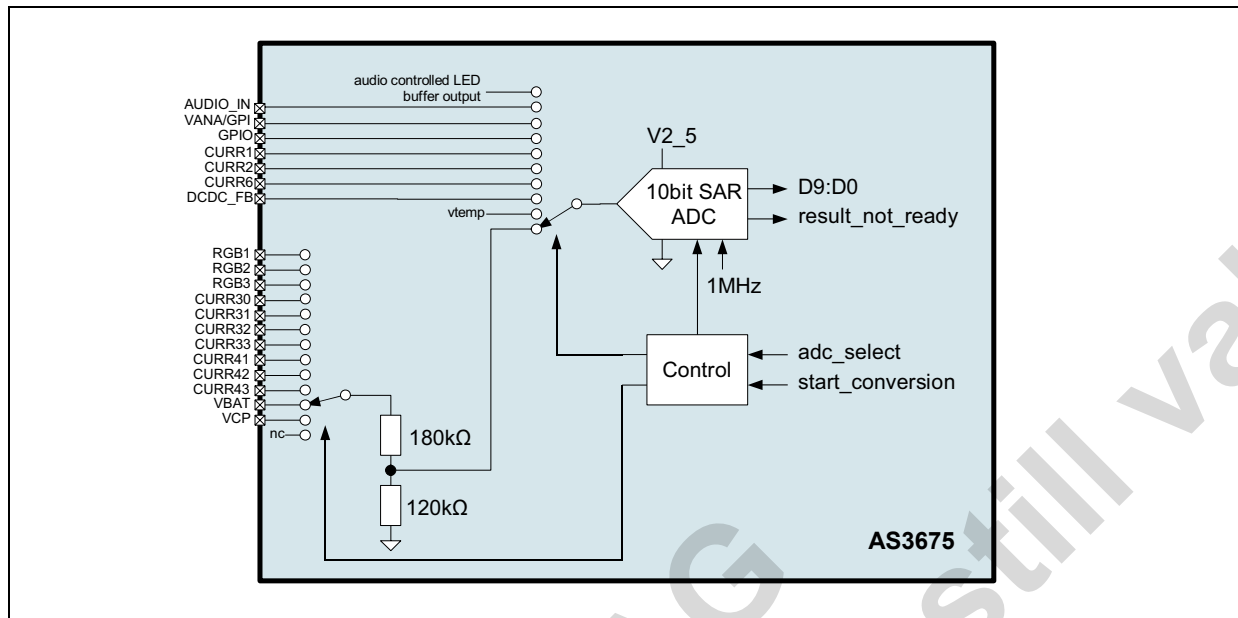

8.8 Audio controlled LEDs

Up to four RGB LEDs and/or up to 13 LEDs (number of LEDs is fully configurable) can be controlled by an audio source (connected to the pin AUDIO_IN). The audio controlled LED block can operate in two modes:

Amplitude Mode: The color of the RGB LED(s) or the brightness of the single color LED(s) is depending on the input amplitude. For the RGB LEDs it starts from black transitions to blue, green, cyan, yellow, red and for high amplitudes white is used (internal lookup table if `audio_color=000b`).

Frequency Mode: Three internal fully configurable filters define the brightness of the single color LED(s) or the color of the RGB LED(s). Each of the filters can be configured individually in amplitude, frequency response and type (lowpass filter, bandpass filter, highpass filter).

Figure 27. Audio controlled LED internal circuit

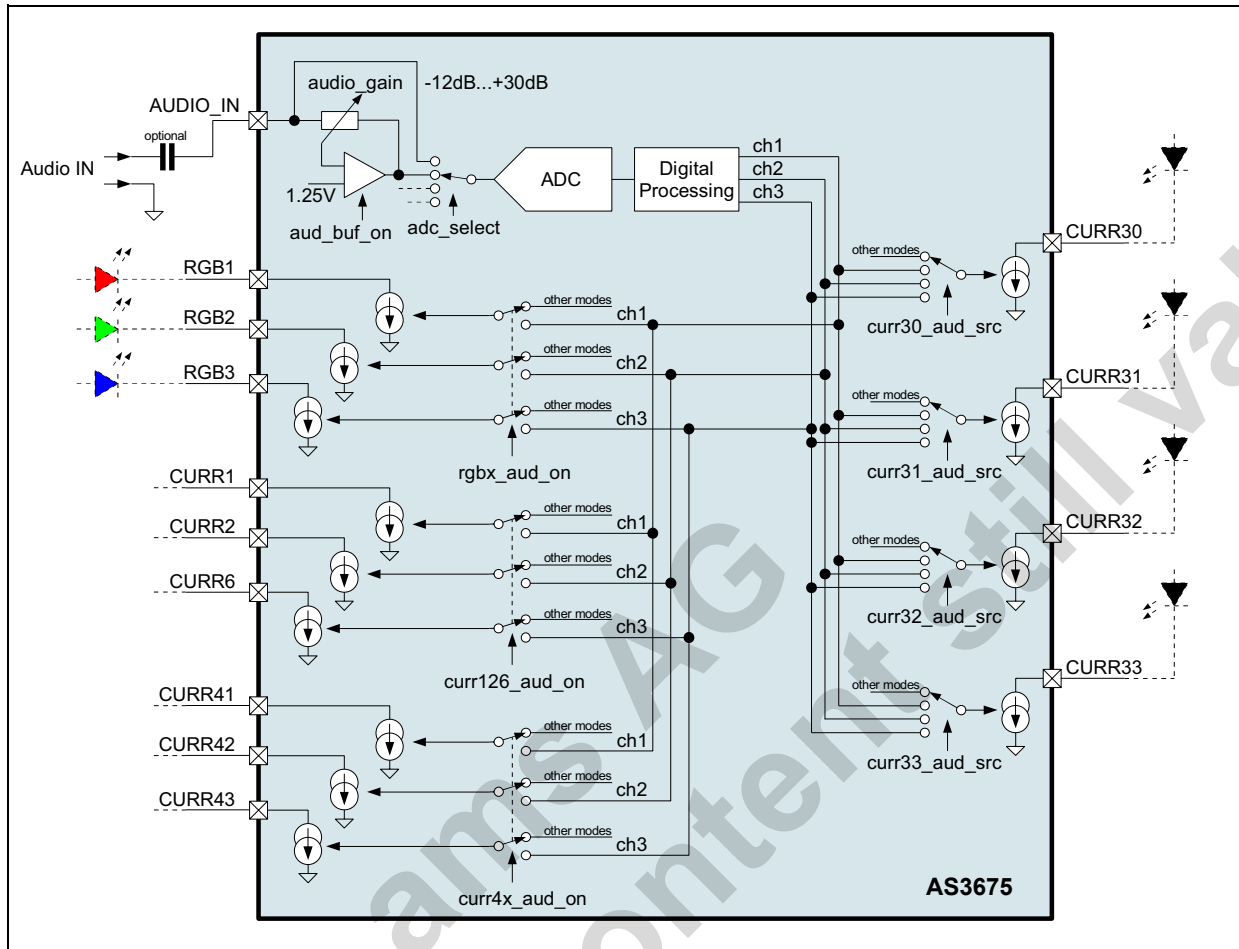

The audio controlled LED block is enabled if any of the registers `curr30_aud_src[1:0]`...`curr33_aud_src[1:0]`, `curr126_aud_on`, `rgbx_aud_on` or `curr4x_aud_on` not equal zero.

The audio input amplifier (enabled by `aud_buf_on=1`) is used to allow the attenuation (or amplification of the input signal) and has the following parameters:

Table 81. Audio input Parameters

Symbol	Parameter	Condition	Min	Typ	Max	Unit
V_{IN}	Input Voltage Range		0		2.5	V
R_{in_min}	min. Input Impedance	at max. input gain (30dB)		20		k Ω

The signal is converted with the ADC (If the audio controlled LED is active, the internal ADC is continuously running at a sample frequency of 45.4kHz. In this case the ADC cannot be used for any other purpose). The digital processing converts this signal into 3 channels (ch1, ch2, ch3):

Figure 28. Audio controlled LED digital processing internal circuit

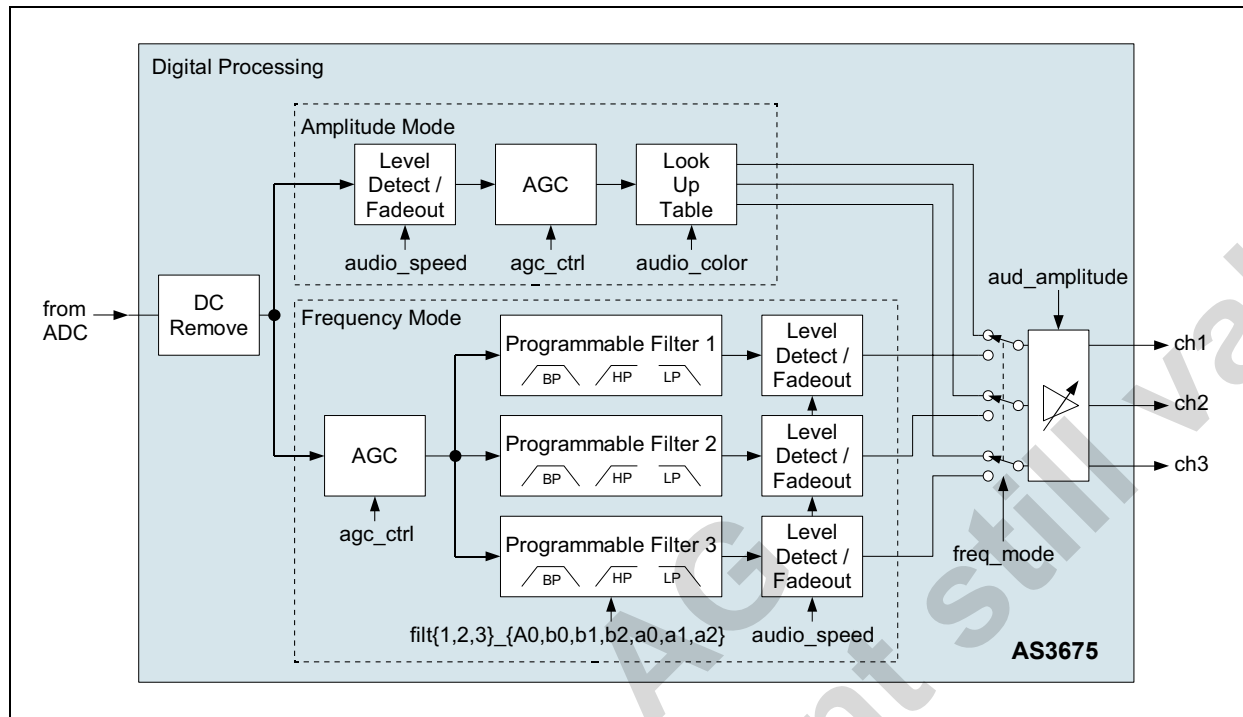

These three output channels (ch1, ch2, ch3) can be routed to any of the current sources according to [Figure 27](#).

The digital processing can be done in two different operating modes (defined by the register bit `freq_mode`):

8.8.1 Amplitude Mode

This mode is selected by `freq_mode=0`.

The input amplitude is mapped into different colors for RGB LED(s) or brightness for single color LED(s). The mapping is controlled by the register `audio_color`. If `audio_color = 000`, then the mapping is done as follows:

Very low amplitudes are mapped to black, for higher amplitudes, the color smoothly transitions from blue, green, cyan, yellow, red and eventually to white (for high input amplitudes).

8.8.2 Frequency Mode

This mode is selected by `freq_mode=1`.

The input signal is frequency filtered by three digital filters. The filters are 2nd order biquad IIR (infinite impulse response filters). Each of these filters has the following structure (sampling frequency = 45.4kHz / internal clock of 1MHz divided by 22):

Figure 29. Audio controlled LED frequency filter

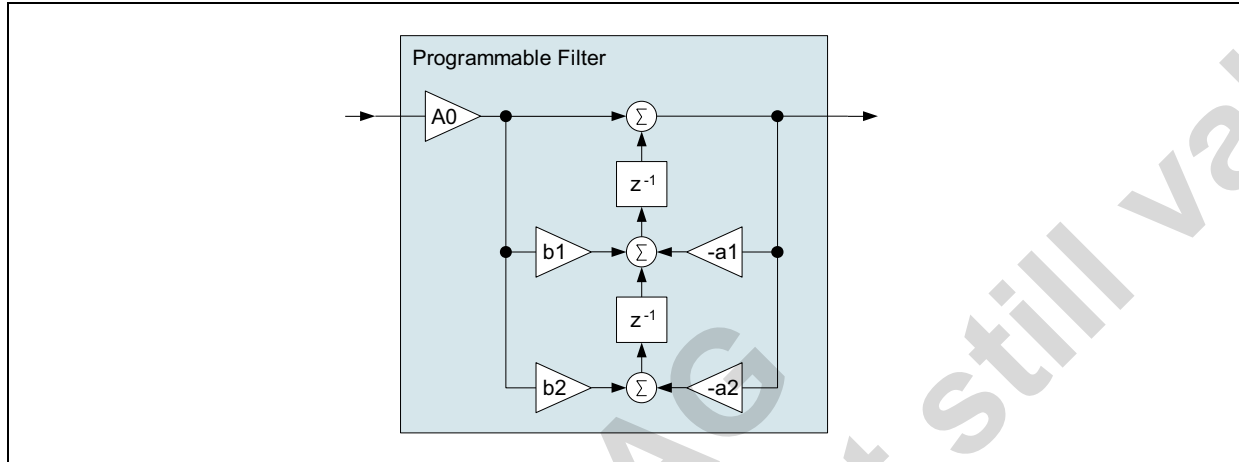

The mathematical formula for these filters is:

$$y(n) = A0(x(n) + b1 x(n-1) + b2 x(n-2)) - a1 y(n-1) - a2 y(n-2) \quad (\text{EQ 6})$$

The internal calculation is performed using 12bits coefficients (state variables (z^{-1}) are rounded to 12bit, the output uses 8bits). All coefficients can be set individually for each of the three filters (filter1, filter2, filter3). (see [Audio Controlled LED Registers on page 62](#)), registers `filt_type` (70h) and registers 71h to 82h. It is recommended to use austriamicrosystems 'Demoboard Software' for simple control of the filter cutoff frequencies and filter type.

Note: Do not set filter cutoff frequencies below 500Hz.

8.8.3 AGC

The AGC (available in amplitude and frequency mode) is used to 'compress' the input signal and to attenuate very low input amplitude signals (this is performed to ensure no light output for low signals especially for noisy input signals).

The AGC monitors the input signal amplitude and filters this amplitude with a filter with a short attack time, but a long decay time (decay time depends on the register `agc_ctrl`). This amplitude measurement (represented by an integer value from 0 to 15) is then used to amplify or attenuate the input signal with one of the following amplification ratios (output to input ratio) – the curve A, B, or C is selected depending on the register `agc_ctrl`:

Figure 30. AGC curve A (x-axis: input amplitude, y-axis: output amplitude; actual value: gain between output to input)

15																		1,3	1,2	1,1	1,0
14									1,8	1,6	1,4	1,3									
13					3,3	2,6	2,2	1,9													
12				4,0																	
11				4,0																	
10				4,0																	
9				4,0																	
8			4,0																		
7			4,0																		
6			4,0																		
5			4,0																		
4		4,0																			
3		4,0																			
2		4,0																			
1		4,0																			
0	0,0																				
	0	1	2	3	4	5	6	7	8	9	10	11	12	13	14	15					

Figure 31. AGC curve B (x-axis: input amplitude, y-axis: output amplitude; actual value: gain between output to input)

15																					1,0
14																			1,2	1,1	1,0
13										1,4	1,3	1,2									
12								2,0	1,7	1,5											
11							2,2														
10					2,5																
9				3,0																	
8				3,0																	
7				3,0																	
6				3,0																	
5				3,0																	
4				3,0																	
3		3,0																			
2		3,0																			
1		3,0																			
0	0,0																				
	0	1	2	3	4	5	6	7	8	9	10	11	12	13	14	15					

Figure 32. AGC curve C (x-axis: input amplitude, y-axis: output amplitude; actual value: gain between output to input)

15																					1,0
14																				1,1	1,0
13													1,2	1,1							
12											1,3	1,2									
11									1,6	1,4											
10								1,7													
9							1,8														
8					2,0																
7					2,0																
6					2,0																
5					2,0																
4				2,0																	
3				2,0																	
2		2,0																			
1		2,0																			
0	0,0																				
	0	1	2	3	4	5	6	7	8	9	10	11	12	13	14	15					

8.8.4 Audio Controlled LED Registers

Table 82. Audio Control Register

Addr: 46h		Audio Control			
		Audio Sync Mode control			
Bit	Bit Name	Default	Access	Description	
0	aud_buf_on	0b	R/W	Audio input buffer enable	
				0	off; for audio direct input to ADC use <code>adc_select = 00h</code> (AUDIO_IN)
				1	on; set <code>adc_select = 03h</code> (buffer output)
4:2	audio_color	000b	R/W	audio controlled LED color selection (amplitude mode)	
				000	color scheme defined by lookup table
				001-111	single color scheme (b2=R, b1=G, b0=B)
5	freq_mode	0b	R/W	audio controlled LED mode selection	
				0	amplitude mode
				1	frequency mode
7:6	audio_speed	00b	R/W	Audio controlled LED persistence time	
				00	none
				01	200ms
				10	400ms
				11	800ms

Table 83. Audio input Register

Addr: 47h		Audio input			
		Audio Sync input control			
Bit	Bit Name	Default	Access	Description	
2:0	audio_gain	000b	R/W	Audio input buffer gain control	
				000	-12dB
				001	-6dB
				010	0dB
				011	+6dB
				100	+12dB
				101	+18dB
				110	+24dB
				111	+30dB

Table 83. Audio input Register (Continued)

Addr: 47h		Audio input			
		Audio Sync input control			
Bit	Bit Name	Default	Access	Description	
5:3	agc_ctrl	000b	R/W	Audio input buffer AGC function controls AGC switching threshold	
				000	AGC off
				001	Attenuate low amplitude signals otherwise linear response (to remove e.g. noise)
				010	AGC curve A; slow decay of amplitude detection
				011	AGC curve A; fast decay of amplitude detection
				100	AGC curve B; slow decay of amplitude detection
				101	AGC curve B; fast decay of amplitude detection
				110	AGC curve C; slow decay of amplitude detection
				111	AGC curve C; fast decay of amplitude detection
6	audio_man_start ¹	0b	R/W	Startup Control of audio input buffer (used to charge optional external dc blocking capacitor)	
				0	automatic precharging 300us (if audio_dis_start = 0)
				1	continuously precharging (if aud_buf_on = 1)
7	audio_dis_start ²	0b	R/W	Disable Startup Control of audio input buffer (used to charge optional external dc blocking capacitor)	
				0	precharging enabled
				1	precharging disabled

1. Its safe to keep default value

2. Its safe to keep default value

Table 84. Audio output Register

Addr: 48h		Audio output			
		Audio Sync input control			
Bit	Bit Name	Default	Access	Description	
2:0	aud_amplitude	000b	R/W	LED(s) output amplitude control (in percent of selected output current)	
				000	6.25%
				001	12.5%
				010	25%
				011	50%
				100	75%
				101	87.5%
				110	93.75%
				111	100%

Table 84. Audio output Register (Continued)

Addr: 48h		Audio output			
		Audio Sync input control			
Bit	Bit Name	Default	Access	Description	
4	curr126_aud_on	0b	R/W	Audio controlled LED enable for CURR1, CURR2, CURR6	
				0	off
				1	on, audio controlled LED is enabled
5	rgbx_aud_on	0b	R/W	Audio controlled LED enable for RGB1-RGB3	
				0	off
				1	on, audio controlled LED is enabled
6	curr4x_aud_on	0b	R/W	Audio controlled LED enable for CURR41-CURR43	
				0	off
				1	on, audio controlled LED is enabled

Table 85. CURR3x audio source Register

Addr: 53h		CURR3x audio source			
		Controls CURR30,31,32,33 audio outputs and enables audio controlled LED			
Bit	Bit Name	Default	Access	Description	
1:0	curr30_aud_src[1:0]	00b	R/W	Audio controlled LED source for CURR30	
				00	All other modes
				01	ch1 connected to CURR30, audio controlled LED on
				10	ch2 connected to CURR30, audio controlled LED on
				11	ch3 connected to CURR30, audio controlled LED on
3:2	curr31_aud_src[1:0]	00b	R/W	Audio controlled LED source for CURR31	
				00	All other modes
				01	ch1 connected to CURR31, audio controlled LED on
				10	ch2 connected to CURR31, audio controlled LED on
				11	ch3 connected to CURR32, audio controlled LED on
5:4	curr32_aud_src[1:0]	00b	R/W	Audio controlled LED source for CURR32	
				00	All other modes
				01	ch1 connected to CURR32, audio controlled LED on
				10	ch2 connected to CURR32, audio controlled LED on
				11	ch3 connected to CURR32, audio controlled LED on

Table 85. CURR3x audio source Register (Continued)

Addr: 53h		CURR3x audio source			
Controls CURR30,31,32,33 audio outputs and enables audio controlled LED					
Bit	Bit Name	Default	Access	Description	
7:6	curr33_aud_src[1:0]	00b	R/W	Audio controlled LED source for CURR33	
				00	All other modes
				01	ch1 connected to CURR33, audio controlled LED on
				10	ch2 connected to CURR33, audio controlled LED on
				11	ch3 connected to CURR33, audio controlled LED on

Table 86. filt_type Register

Addr: 70h		filt_type			
Define frequency filter types					
Bit	Bit Name	Default	Access	Description	
1:0	filt1_type[1:0]	00b	R/W	Defines filter1 (for ch1) characteristics and filter coefficients b1 and b2	
				00	don't use
				01	low pass filter; filt1_b1=2, filt1_b2=1
				10	high pass filter; filt1_b1=-2, filt1_b2=1
				11	band pass filter; filt1_b1=0, filt1_b2=-1
3:2	filt2_type[1:0]	00b	R/W	Defines filter2 (for ch2) characteristics and filter coefficients b1 and b2	
				00	don't use
				01	low pass filter; filt2_b1=2, filt2_b2=1
				10	high pass filter; filt2_b1=-2, filt2_b2=1
				11	band pass filter; filt2_b1=0, filt2_b2=-1
5:4	filt3_type[1:0]	00b	R/W	Defines filter3 (for ch3) characteristics and filter coefficients b1 and b2	
				00	don't use
				01	low pass filter; filt3_b1=2, filt3_b2=1
				10	high pass filter; filt3_b1=-2, filt3_b2=1
				11	band pass filter; filt3_b1=0, filt3_b2=-1

Registers 71h to 82h define the filter coefficients $\text{filt}\{1,2,3\}_{A0,a1,a2}$. Each of the coefficients is 12 bits wide and is calculated according to the following formula (2s complement number):

- Bit11 is used as sign bit 0...positive number, 1...negative number
- Bit10 is multiplied by 2^0
- Bit9 is multiplied by 2^{-1}
- ...
- Bit 1 is multiplied by 2^{-9}

- Bit 0 is multiplied by 2^{10}

Table 87. Filter Definitions Register

Register Definition Name	Addr	Default	Content							
			b7	b6	b5	b4	b3	b2	b1	b0
filt1_A0_MSB	71h	00h					filt1_A0[11:8]			
filt1_A0_LSB	72h	00h	filt1_A0[7:0]							
filt1_a1_MSB	73h	00h					filt1_a1[11:8]			
filt1_a1_LSB	74h	00h	filt1_a1[7:0]							
filt1_a2_MSB	75h	00h					filt1_a2[11:8]			
filt1_a2_LSB	76h	00h	filt1_a2 [7:0]							
filt2_A0_MSB	77h	00h					filt2_A0[11:8]			
filt2_A0_LSB	78h	00h	filt2_A0[7:0]							
filt2_a1_MSB	79h	00h					filt2_a1[11:8]			
filt2_a1_LSB	7ah	00h	filt2_a1[7:0]							
filt2_a2_MSB	7bh	00h					filt2_a2[11:8]			
filt2_a2_LSB	7ch	00h	filt2_a2 [7:0]							
filt3_A0_MSB	7dh	00h					filt3_A0[11:8]			
filt3_A0_LSB	7eh	00h	filt3_A0[7:0]							
filt3_a1_MSB	7fh	00h					filt3_a1[11:8]			
filt3_a1_LSB	80h	00h	filt3_a1[7:0]							
filt3_a2_MSB	81h	00h					filt3_a2[11:8]			
filt3_a2_LSB	82h	00h	filt3_a2[7:0]							

8.9 Power-On Reset

The internal reset is controlled by two sources:

- VBAT Supply
- Serial interface state (CLK, DATA)

The internal reset is forced if VBAT is low or if both interface pins (CLK, DATA) are low for more than t_{POR_DEB} (typ. 100ms)². Then device enters shutdown mode.

The reset levels control the state of all registers. As long as VBAT and CLK/DATA are below their reset thresholds, the register contents are set to default. Access by serial interface is possible once the reset thresholds are exceeded.

2. Only if `shutdwn_enab=1`

Figure 33. Zero Power Device Wakeup block diagram

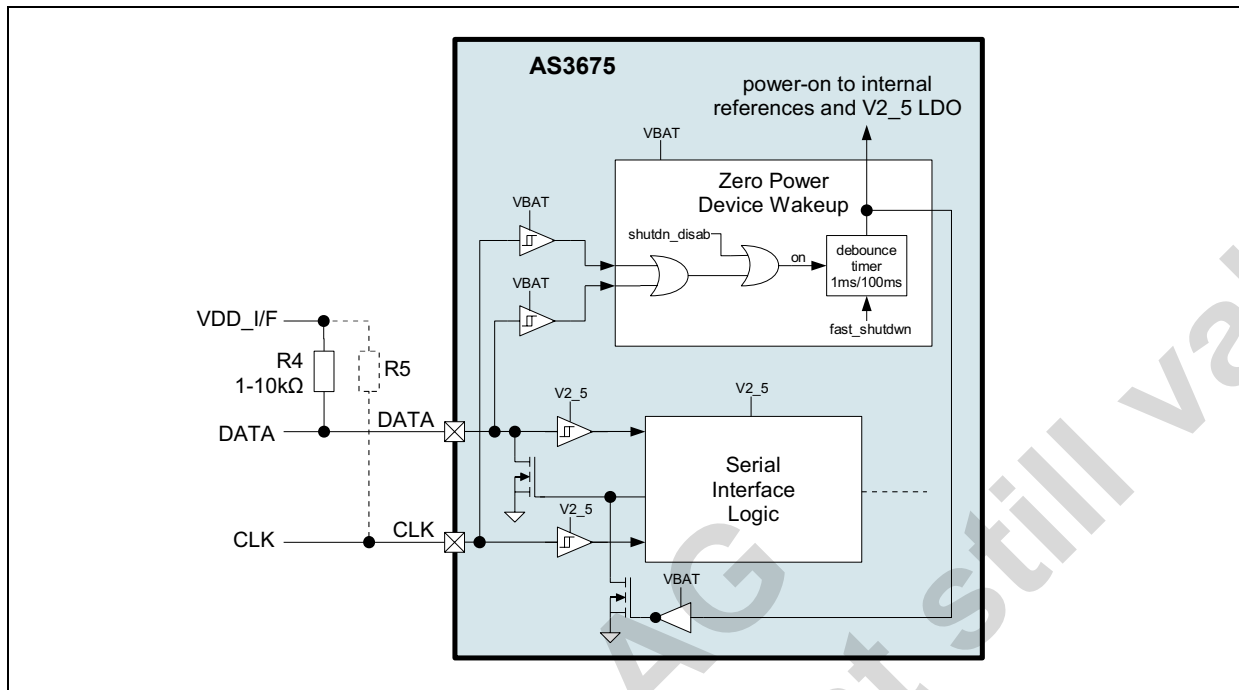

Table 88. Audio input Parameters

Symbol	Parameter	Condition	Min	Typ	Max	Unit
VPOR_VBAT	Overall Power-On Reset	Monitor voltage on V2_5; power-on reset for all internal functions.	1.8	2.15	2.4 ¹	V
VPOR_PERI	Reset Level for pins CLK, DATA	Monitor voltage on pins CLK, DATA	0.29	1.0	1.38	V
tPOR_DEB	Reset debounce time for pins CLK, DATA		80	100	120	ms
tstart	Interface Startup Time		4	6	8	ms

1. Guaranteed by design - min./max. limits not production tested

8.9.1 Reset control register

Table 89. Overtemp control Register

Addr: 29h		Overtemp control			
This register reads and resets the overtemperature flag.					
Bit	Bit Name	Default	Access	Description	
4	shutdwn_enab	0	R/W	Enable Shutdown mode and serial interface reset.	
				0	Serial Interface reset disabled. Device does not enter Shutdown mode
				1	Serial Interface reset enabled, device enters shutdown when SCL and SDA remain low for min. 120ms

8.10 Temperature Supervision

An integrated temperature sensor provides over-temperature protection for the AS3675. This sensor generates a flag if the device temperature reaches the overtemperature threshold of 140°. The threshold has a hysteresis to prevent oscillation effects.

If the device temperature exceeds the T_{140} threshold all current sources, the charge pump and the dcdc converter is disabled and the `ov_temp` flag is set. After decreasing the temperature by T_{HYST} operation is resumed.

The `ov_temp` flag can only be reset by first writing a 1 and then a 0 to the register bit `rst_ov_temp`.

Bit `ov_temp_on` = 1 activates temperature supervision [Table 91](#). It is recommend to leave this bit set (default state).

Table 90. Overtemperature Detection

Symbol	Parameter	Condition	Min	Typ	Max	Unit
T_{140}	ov_temp Rising Threshold			140		°C
T_{HYST}	ov_temp Hysteresis			5		°C

Table 91. Overtemp control Register

Addr: 29h		Overtemp control				
This register reads and resets the overtemperature flag.						
Bit	Bit Name	Default	Access	Description		
0	<code>ov_temp_on</code>	1	W	Activates/deactivates device temperature supervision. Default: Off - all other bits are only valid if this bit is set to 1		
				0	Temperature supervision is disabled. No reset will be generated if the device temperature exceeds 140°C	
				1	Temperature supervision is enabled	
1	<code>ov_temp</code>	N/A	R	1	Indicates that the overtemperature threshold has been reached; this flag is not cleared by an overtemperature reset. It has to be cleared using <code>rst_ov_temp</code>	
2	<code>rst_ov_temp</code>	0	R/W	The <code>ov_temp</code> flag is cleared by first setting this bit to 1, and then setting this bit to 0.		

8.11 Serial Interface

The AS3675 is controlled using serial interface pins CLK and DATA:

Figure 34. Serial interface block diagram

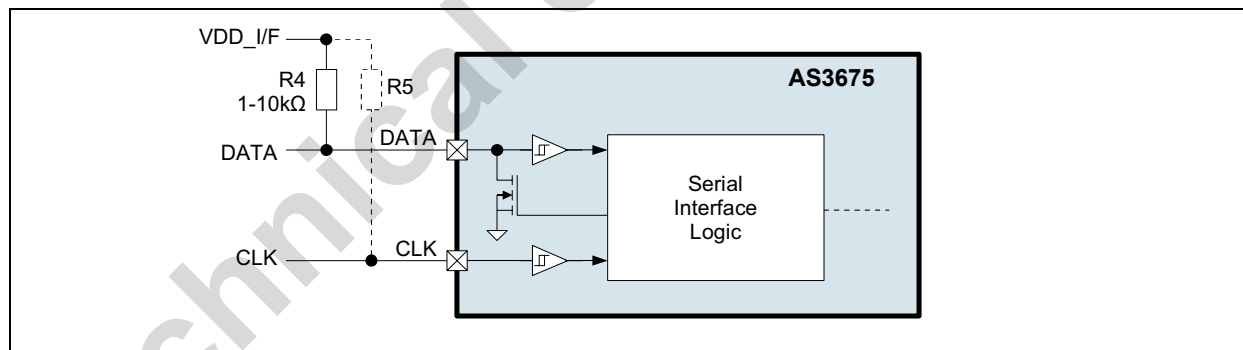

The clock line CLK is never held low by the AS3675 (as the AS3675 does not use clock stretching of the bus).

Table 92. Serial Interface Timing

Symbol	Parameter	Condition	Min	Typ	Max	Unit
V _{IHI/F}	High Level Input Voltage	Pins DATA and CLK	1.38		V _{BAT}	V
V _{ILI/F}	Low Level Input Voltage		0.0		0.52	V
V _{HYSTI/F}	Hysteresis			0.1		V
t _{RISE}	Rise Time		0		1000	ns
t _{FALL}	Fall Time		0		300	ns
t _{CLK_FILTER}	Spike Filter on CLK			100		ns
t _{DATA_FILTER}	Spike Filter on DATA			300		ns

The AS3675 is compatible to the NXP two wire specification http://www.nxp.com/acrobat_download/literature/9398/39340011.pdf, Version 2.1, January 2000 for standard and fast mode (no high speed mode) with the following exception:

Data set-up time for fast mode: t_{SU;DAT}=250ns (instead of 100ns from table 5, p32)

8.11.1 Serial Interface Features

- Fast Mode Capability (Maximum Clock Frequency is 400 kHz)
- 7-bit Addressing Mode
- Write Formats
 - Single-Byte Write
 - Page-Write
- Read Formats
 - Current-Address Read
 - Random-Read
 - Sequential-Read
- DATA Input Delay and CLK spike filtering by integrated RC components

8.11.2 Device Address Selection

The serial interface address of the AS3675 has the following address:

- 80h – Write Commands
- 81h – Read Commands

Figure 35. Complete Serial Data Transfer

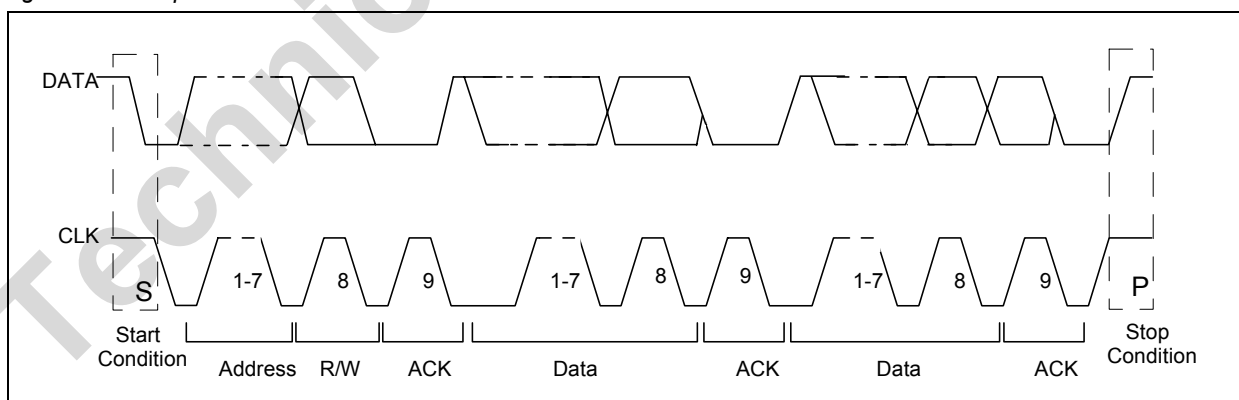

Serial Data Transfer Formats

Definitions used in the serial data transfer format diagrams are listed in the following table:

Table 93. Serial Data Transfer Byte Definitions

Symbol	Definition	R/W (AS3675 Slave)	Note
S	Start Condition after Stop	R	1 bit
Sr	Repeated Start	R	1 bit
DW	Device Address for Write	R	1000000b (80h).
DR	Device Address for Read	R	1000001b (81h)
WA	Word Address	R	8 bits
A	Acknowledge	W	1 bit
N	Not Acknowledge	R	1 bit
reg_data	Register Data/Write	R	8 bits
data (n)	Register Data/read	R	1 bit
P	Stop Condition	R	8 bits
WA++	Increment Word Address Internally	R	During Acknowledge

Figure 36. Serial Interface Byte Write

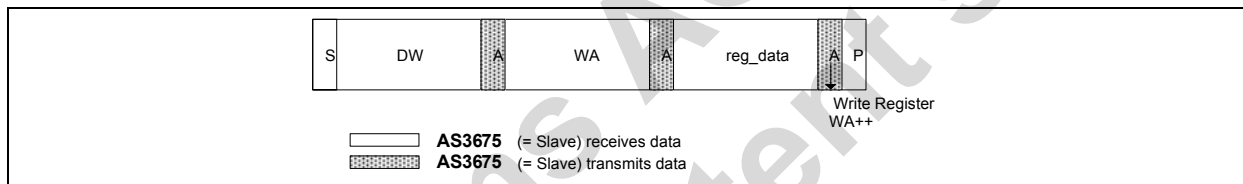
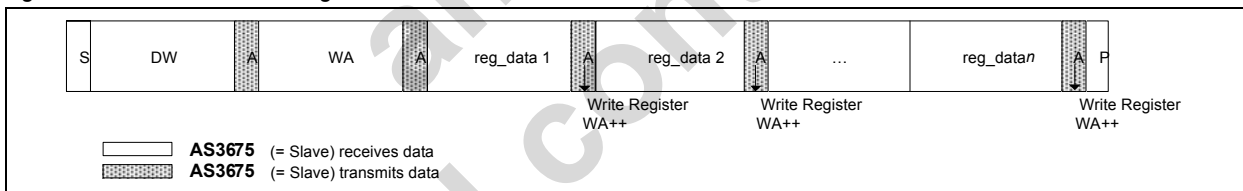

Figure 37. Serial Interface Page Write



Byte Write and Page Write formats are used to write data to the slave.

The transmission begins with the START condition, which is generated by the master when the bus is in IDLE state (the bus is free). The device-write address is followed by the word address. After the word address any number of data bytes can be sent to the slave. The word address is incremented internally, in order to write subsequent data bytes on subsequent address locations.

For reading data from the slave device, the master has to change the transfer direction. This can be done either with a repeated START condition followed by the device-read address, or simply with a new transmission START followed by the device-read address, when the bus is in IDLE state. The device-read address is always followed by the 1st register byte transmitted from the slave. In Read Mode any number of subsequent register bytes can be read from the slave. The word address is incremented internally.

The following diagrams show the serial read formats supported by the AS3675.

Figure 38. Serial Interface Random Read

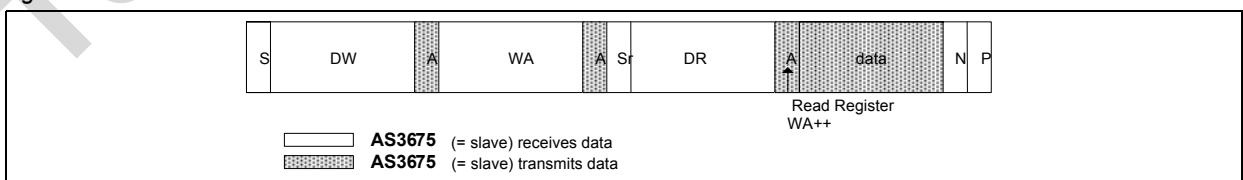

Random Read and Sequential Read are combined formats. The repeated START condition is used to change the direction after the data transfer from the master.

The word address transfer is initiated with a START condition issued by the master while the bus is idle. The START condition is followed by the device-write address and the word address.

In order to change the data direction a repeated START condition is issued on the 1st CLKpulse after the ACKNOWLEDGE bit of the word address transfer. After the reception of the device-read address, the slave becomes the transmitter. In this state the slave transmits register data located by the previous received word address vector. The master responds to the data byte with a NOT ACKNOWLEDGE, and issues a STOP condition on the bus.

Figure 39. Serial Interface Sequential Read

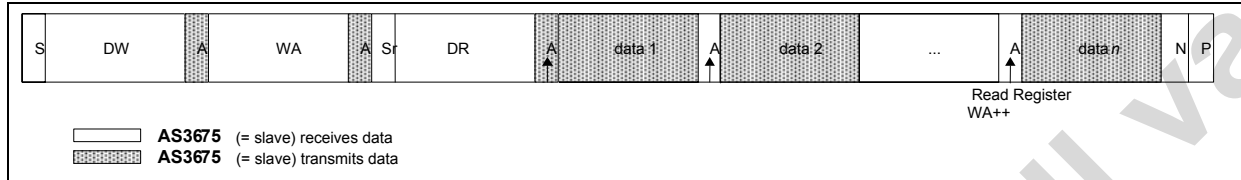

Sequential Read is the extended form of Random Read, as multiple register-data bytes are subsequently transferred. In contrast to the Random Read, in a sequential read the transferred register-data bytes are responded by an acknowledge from the master. The number of data bytes transferred in one sequence is unlimited (consider the behavior of the word-address counter). To terminate the transmission the master has to send a NOT ACKNOWLEDGE following the last data byte and subsequently generate the STOP condition.

Figure 40. Serial Interface Current Address Read

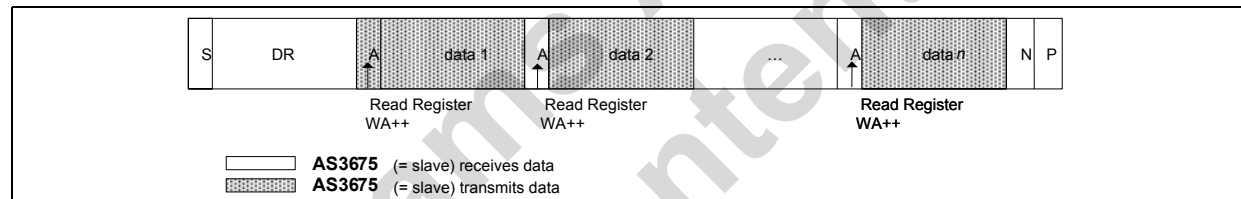

To keep the access time as small as possible, this format allows a read access without the word address transfer in advance to the data transfer. The bus is idle and the master issues a START condition followed by the Device-Read address.

Analogous to Random Read, a single byte transfer is terminated with a NOT ACKNOWLEDGE after the 1st register byte. Analogous to Sequential Read an unlimited number of data bytes can be transferred, where the data bytes must be responded to with an ACKNOWLEDGE from the master.

For termination of the transmission the master sends a NOT ACKNOWLEDGE following the last data byte and a subsequent STOP condition.

8.12 Operating Modes

If the voltage on CLK and DATA is less than 1V (for t_{POR_DEB}), the AS3675 is in shutdown mode and its current consumption is minimized ($I_{BAT} = I_{SHUTDOWN}$) and all internal registers are reset to their default values.

If the voltage at CLK or DATA rises above 1V, the AS3675 serial interface is enabled and the AS3675 and the standby mode is selected. The AS3675 is switched automatically from standby mode ($I_{BAT} = I_{STANDBY}$) into normal mode ($I_{BAT} = I_{ACTIVE}$) and back, if one of the following blocks are activated:

- Charge pump
- Step up regulator
- Any current sink
- ADC conversion started
- PWM active
- Pattern mode active.

If any of these blocks are already switched on the internal oscillator is running and a write instruction to the registers is directly evaluated within 1 internal CLK cycle (typ. 1 μ s)

If all these blocks are disabled, a write instruction to enable these blocks is delayed by 64 CLK cycles (oscillator will startup, within max 200µs).

ams AG
Technical content still valid

9 Register Map

Table 94. Registermap

Register Definition Name	Addr	Default	Content								
			b7	b6	b5	b4	b3	b2	b1	b0	
Reg. control	00h	00	ldo_ana _lpo				step_up _on	cp_on		ldo_ana _on	
curr12 control	01h	00h					curr2_mode		curr1_mode		
curr rgb control	02h	00h	curr6_mode		rgb3_mode		rgb2_mode		rgb1_mode		
curr3 control1	03h	00h	curr33_mode		curr32_mode		curr31_mode		curr30_mode		
curr4 control	04h	00h			curr43_mode		curr42_mode		curr41_mode		
GPIO output 1	05h	00h	gpi_curr 33_en	gpi_curr 32_en	gpi_curr 31_en	gpi_curr 30_en		gpi_curr 6_en	gpi_curr 2_en	gpi_curr 1_en	
GPIO signal 1	06h	00h	gpi_curr 33_in	gpi_curr 32_in	gpi_curr 31_in	gpi_curr 30_in		gpi_curr 6_in	gpi_curr 2_in	gpi_curr 1_in	
LDO ANA1 Voltage	07h	00h	ldo_ana_voltage								
Curr1 current	09h	00h	curr1_current								
Curr2 current	0Ah	00h	curr2_current								
Rgb1 current	0Bh	00h	rgb1_current								
Rgb2 current	0Ch	00h	rgb2_current								
Rgb3 current	0Dh	00h	rgb3_current								
Curr3x strobe	0Eh	00h	curr3x_strobe								
Curr3x preview	0Fh	00h	curr3x_preview								
Curr3x other	10h	00h	curr3x_other								
Curr3 strobe control	11h	00h	strobe_timing				strobe_mode		strobe_ctrl		
Curr3 control2	12h	00h	strobe_p in		curr3x_s trobe_hi gh			preview_ctrl		preview off_after strobe	
Curr41 current	13h	00h	curr41_current								
Curr42 current	14h	00h	curr42_current								
Curr43 current	15h	00h	curr43_current								
Pwm control	16h	00h			pwm_dim_speed			pwm_dim_mode			
pwm code	17h	00h	pwm_code								
Pattern control	18h	00h	curr33_p attern	curr32_p attern	curr31_p attern	curr30_p attern	softdim_ pattern	pattern_delay		pattern_ color	
Pattern data0	19h	00h	pattern_data[7:0]								
Pattern data1	1Ah	00h	pattern_data[15:8]1111								
Pattern data2	1Bh	00h	pattern_data[23:16]1111								
Pattern data3	1Ch	00h	pattern_data[31:24]1111								
GPIO control	1Eh	44h					gpio_pulls		gpio_mode		
GPIO driving cap	20h	00h									gpio_low _curr

Table 94. Registermap

Register Definition Name	Addr	Default	Content							
			b7	b6	b5	b4	b3	b2	b1	b0
DCDC control1	21h	00h	step_up_vtuning					step_up_fb		step_up_frequ
DCDC control2	22h	04h	step_up_fb_auto	curr6_pr ot_on	curr2_pr ot_on	curr1_pr ot_on	Step up_lowc ur	step_up _prot	skip_fast	step_up _res
CP control	23h	00h		cp_auto _on	cp_start _deboun ce	cp_mode_switchin g		cp_mode		cp_clk
CP mode Switch1	24h	00h		rgb3_on _cp	rgb2_on _cp	rgb1_on _cp	curr33_o n_cp	curr32_o n_cp	curr31_o n_cp	curr30_o n_cp
CP mode Switch2	25h	00h	curr6_on _cp			curr43_o n_cp	curr42_o n_cp	curr41_o n_cp	curr2_on _cp	curr1_on _cp
ADC_control	26h	03h	start_co nversion	adc_on	adc_select					
ADC_MSB result	27h	NA	result_n ot_ready	D9:D3						
ADC_LSB result	28h	NA						D2:D0		
Overtemp control	29h	01h				shutdwn _enab		rst_ov_t emp	ov_temp	ov_temp _on
Curr low voltage status1	2Ah	NA	curr6_lo w_v	rgb3_low _v	rgb2_low _v	rgb1_low _v	curr33_l ow_v	curr32_l ow_v	curr31_l ow_v	curr30_l ow_v
Curr low voltage status2	2Bh	NA				curr43_l ow_v	curr42_l ow_v	curr41_l ow_v	curr2_lo w_v	curr1_lo w_v
gpio current	2Ch	00h		pattern_ slow		pattern_ delay2				
curr6 current	2Fh	00h	curr6_current							
Adder Current 1	30h	00h	adder_current1 (can be enabled for CURR30, CURR1, RGB1, CURR41)							
Adder Current 2	31h	00h	adder_current2 (can be enabled for CURR31, CURR2, RGB2, CURR42)							
Adder Current 3	32h	00h	adder_current3 (can be enabled for CURR32, CURR6, RGB3, CURR43)							
Adder Enable 1	33h	00h			curr43_a dder	curr42_a dder	curr41_a dder	rgb3_ad der	rgb2_ad der	rgb1_ad der
Adder Enable 2	34h	00h		curr33_a dder	curr32_a dder	curr31_a dder	curr30_a dder	curr6_ad der	curr2_ad der	curr1_ad der
Subtract Enable	35h	00h					sub_en4	sub_en3	sub_en2	sub_en1
ASIC ID1	3Eh	CBh	1	1	0	0	1	0	1	1
ASIC ID2	3Fh	5Xh	0	1	0	1	revision			
Curr30 current	40h	00h	curr30_current							
Curr31 current	41h	00h	curr31_current							
Curr32 current	42h	00h	curr32_current							
Curr33 current	43h	00h	curr33_current							
Audio Control	46h	00h	audio_speed	freq_mo de	audio_color					aud_buf _on

Table 94. Registermap

Register Definition Name	Addr	Default	Content								
			b7	b6	b5	b4	b3	b2	b1	b0	
Audio input	47h	00h	audio_di s_start	audio_m an_start	agc_ctrl			audio_gain			
Audio output	48h	00h		curr4x_a ud_on	rgbx_au d_on	curr126_ aud_on	aud_amplitude				
GPIO output 2	50h	00h	gpi_curr 43_en	gpi_curr 42_en	gpi_curr 41_en	gpi_rgb3 _en	gpi_rgb2 _en	gpi_rgb1 _en	gpi_en	gpio_out	
GPIO signal 2	51h	00h	gpi_curr 43_in	gpi_curr 42_in	gpi_curr 41_in	gpi_rgb3 _in	gpi_rgb2 _in	gpi_rgb1 _in	gpi_in	gpio_in	
Adder Current 4	52h	00h	adder_current4 (can be enabled for CURR33)								
CURR3x audio source	53h	00h	curr33_aud_src[1:0]	curr32_aud_src[1:0]	curr31_aud_src[1:0]	curr30_aud_src[1:0]					
Pattern End	54h	00h								pattern_ end	
filt_type	70h	00h			filt3_type[1:0]	filt2_type[1:0]	filt1_type[1:0]				
filt1_A0_MSB	71h	00h					filt1_A0[11:8]				
filt1_A0_LSB	72h	00h	filt1_A0[7:0]								
filt1_a1_MSB	73h	00h					filt1_a1[11:8]				
filt1_a1_LSB	74h	00h	filt1_a1[7:0]								
filt1_a2_MSB	75h	00h					filt1_a2[11:8]				
filt1_a2_LSB	76h	00h	filt1_a2 [7:0]								
filt2_A0_MSB	77h	00h					filt2_A0[11:8]				
filt2_A0_LSB	78h	00h	filt2_A0[7:0]								
filt2_a1_MSB	79h	00h					filt2_a1[11:8]				
filt2_a1_LSB	7ah	00h	filt2_a1[7:0]								
filt2_a2_MSB	7bh	00h					filt2_a2[11:8]				
filt2_a2_LSB	7ch	00h	filt2_a2 [7:0]								
filt3_A0_MSB	7dh	00h					filt3_A0[11:8]				
filt3_A0_LSB	7eh	00h	filt3_A0[7:0]								
filt3_a1_MSB	7fh	00h					filt3_a1[11:8]				
filt3_a1_LSB	80h	00h	filt3_a1[7:0]								
filt3_a2_MSB	81h	00h					filt3_a2[11:8]				
filt3_a2_LSB	82h	00h	filt3_a2[7:0]								

Note: If writing to register, write 0 to unused bits

Write to read only bits will be ignored

yellow color = read only

10 External Components

Table 95. External Components List

Part Number	Min	Value Typ	Max	tol. (min.)	Rating (max)	Notes	Package (min.)
C1		1 μ F		\pm 20%	6.3V	Ceramic, X5R (V2_5 output) (e.g. Taiyo Yuden JMK105BJ105KV-F)	0402
C2		1 μ F		\pm 20%	6.3V	Ceramic, X5R (VBAT) (e.g. Taiyo Yuden JMK105BJ105KV-F)	0402
C3		1 μ F		\pm 20%	6.3V	Ceramic, X5R (Charge Pump) (e.g. Taiyo Yuden JMK105BJ105KV-F)	0402
C4		1 μ F		\pm 20%	6.3V	Ceramic, X5R (Charge Pump) (e.g. Taiyo Yuden JMK105BJ105KV-F)	0402
C5		2.2 μ F		\pm 20%	6.3V	Ceramic, X5R (Charge Pump Output) (e.g. Taiyo Yuden JMK107BJ225MA-T)	0403
C6		1 μ F		\pm 20%	6.3V	Ceramic, X5R (Step Up DCDC input) (e.g. Taiyo Yuden JMK105BJ105KV-F)	0402
C7		1.5nF		\pm 20%	25V	Ceramic, X5R (Step Up DCDC Feedback, 150pF for over voltage protection)	0402
C8		15nF		\pm 20%	6.3V	Ceramic, X5R (Step Up DCDC Feedback, 1.5nF for over voltage protection)	0402
C9		4.7 μ F		\pm 20%	25V	Ceramic, X5R, X7R (Step Up DCDC output) (e.g. Taiyo Yuden TMK316BJ475KG)	3.2x1.6x 1.25mm
C10		2.2 μ F		\pm 20%	6.3V	Ceramic, X5R (Vana1 output) (e.g. Taiyo Yuden JMK107BJ225MA-T) only required if LDO is used	0403
R1		100m Ω		\pm 5%		Shunt Resistor	0603
R2		1M Ω		\pm 1%		Step Up DC/DC Converter Voltage Feedback	0201
R3		100k Ω		\pm 1%		Step Up DC/DC Converter Voltage Feedback - not required for over voltage protection	0201
R4		1-10k Ω		\pm 1%		DATA Pullup resistor – usually already inside master	0201
R5						CLKPullup resistor – usually already inside master	0201
L1		10 μ H		\pm 20%		Recommended Type: Murata LQH3NPN100NJ0, Panasonic ELLSFG100MA or TDK VLF3012A	3x3x1.2mm
Q1 (+ D1)		FDFMA3N109				Integrated NMOS and Schottky diode	MicroFET 2x2mm
D2:D14		LED				As required by application	

11 Package Drawings and Markings

Figure 41. WL-CSP30 3x2.5mm 6x5 Balls Package Drawing

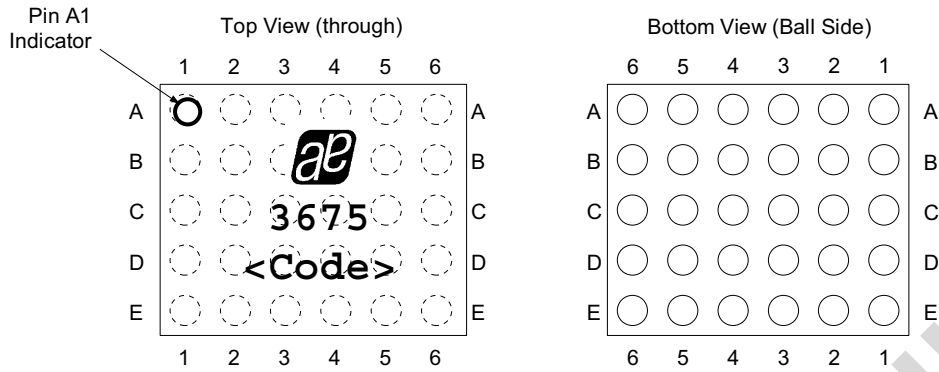

Note:

- Line 1: austriamicrosystems logo
- Line 2: 3675
- Line 3: <Code>
Encode datecode 4 characters

Figure 42. WL-CSP30 3x2.5mm 6x5 Balls Detail Dimensions

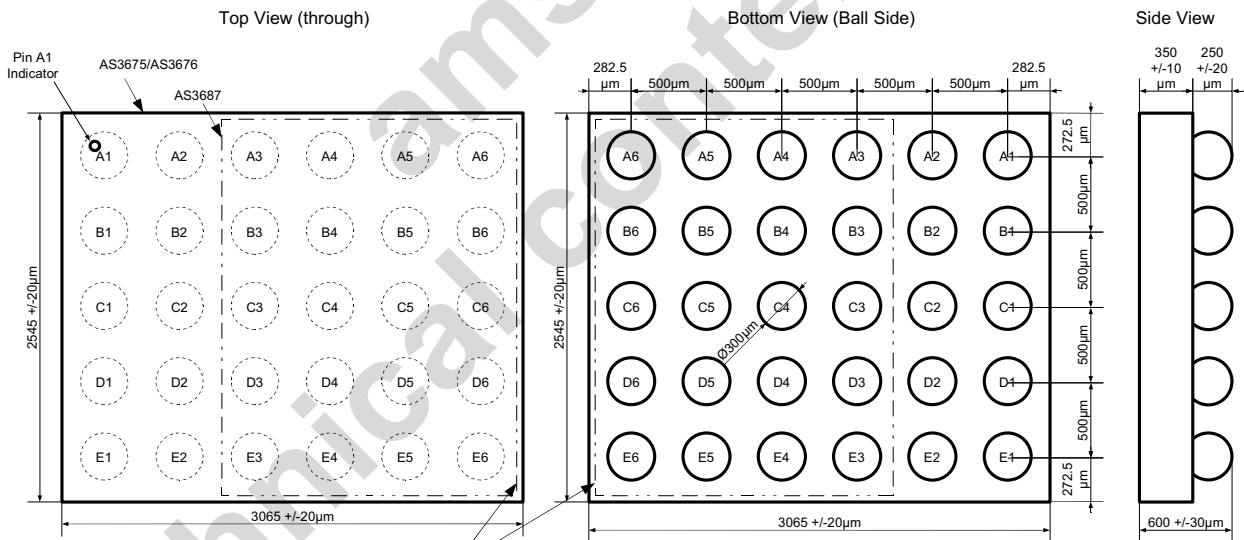

Balls A3-A6, B3-... to E3-E6 are pin-compatible to AS3687; a single PCB can use the identical layout for AS3687 and AS3675/76 and solder AS3687 or AS3675/76 depending on the functions required

11.1 Tape & Reel Information

Figure 43. Tape & Reel Dimensions

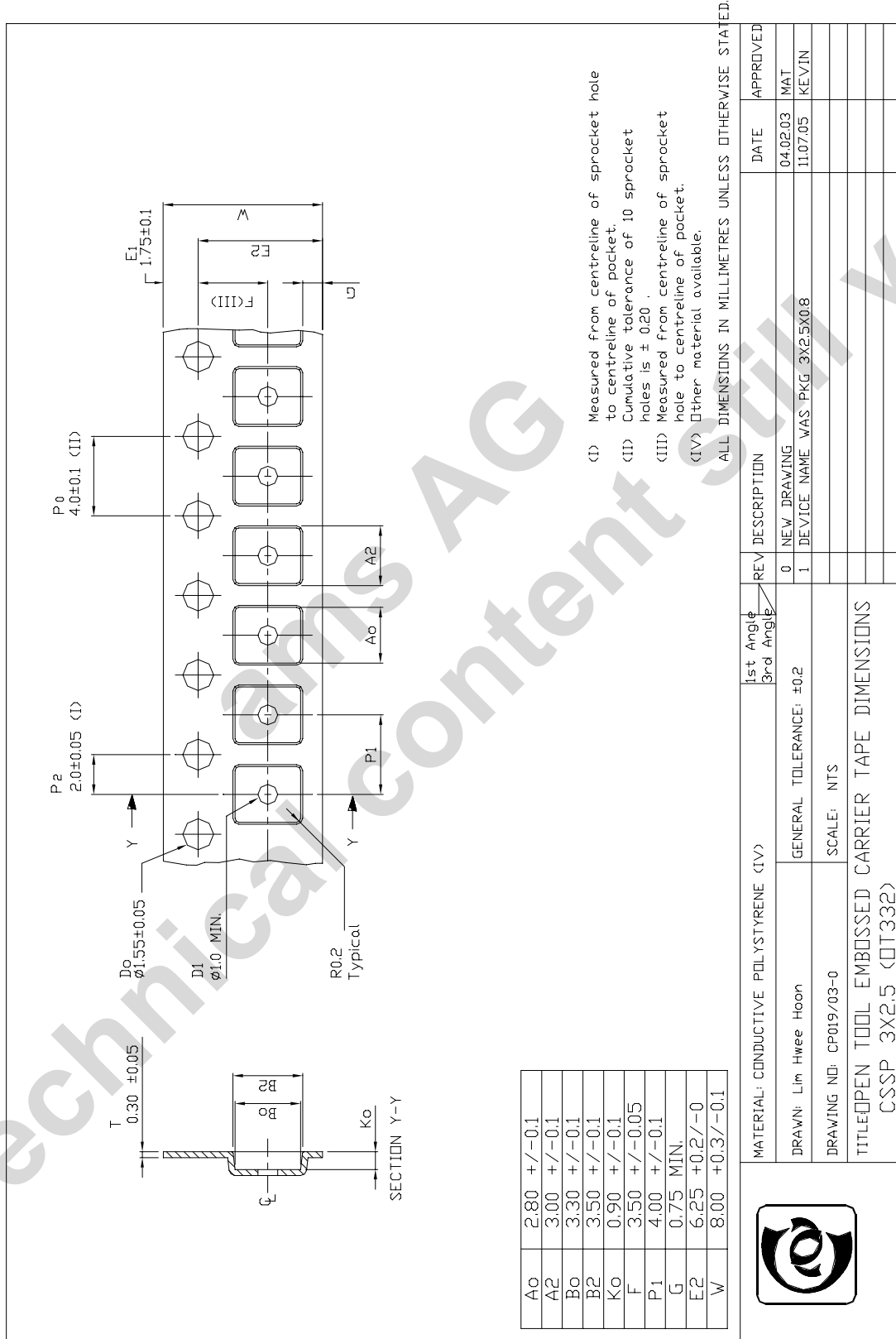

12 Ordering Information

The devices are available as the standard products shown in [Table 96](#).

Table 96. Ordering Information

Model	Description	Delivery Form	Package
AS3675-ZWLT	AS3675 Wafer Level Chip Scale Package, size 3x2.5mm, 6x5 balls, 0.5mm pitch, Pb-Free	Tape & Reel	30pin WL-CSP (3x2.5mm) RoHS compliant / Pb-Free

Note: AS3675-ZWLT

AS3675-

Z Temperature Range: -30°C - 85°C

WL Package: Wafer Level Chip Scale Package (WL-CSP) 3x2.5mm

T Delivery Form: Tape & Reel

Copyrights

Copyright © 1997-2010, austriamicrosystems AG, Tobelbaderstrasse 30, 8141 Unterpremstaetten, Austria-Europe. Trademarks Registered ®. All rights reserved. The material herein may not be reproduced, adapted, merged, translated, stored, or used without the prior written consent of the copyright owner.

All products and companies mentioned are trademarks or registered trademarks of their respective companies.

Disclaimer

Devices sold by austriamicrosystems AG are covered by the warranty and patent indemnification provisions appearing in its Term of Sale. austriamicrosystems AG makes no warranty, express, statutory, implied, or by description regarding the information set forth herein or regarding the freedom of the described devices from patent infringement. austriamicrosystems AG reserves the right to change specifications and prices at any time and without notice. Therefore, prior to designing this product into a system, it is necessary to check with austriamicrosystems AG for current information. This product is intended for use in normal commercial applications. Applications requiring extended temperature range, unusual environmental requirements, or high reliability applications, such as military, medical life-support or life-sustaining equipment are specifically not recommended without additional processing by austriamicrosystems AG for each application. For shipments of less than 100 parts the manufacturing flow might show deviations from the standard production flow, such as test flow or test location.

The information furnished here by austriamicrosystems AG is believed to be correct and accurate. However, austriamicrosystems AG shall not be liable to recipient or any third party for any damages, including but not limited to personal injury, property damage, loss of profits, loss of use, interruption of business or indirect, special, incidental or consequential damages, of any kind, in connection with or arising out of the furnishing, performance or use of the technical data herein. No obligation or liability to recipient or any third party shall arise or flow out of austriamicrosystems AG rendering of technical or other services.



Contact Information

Headquarters

austriamicrosystems AG
Tobelbaderstrasse 30
Schloss Premstätten
A-8141 Austria

Tel: +43 (0) 3136 500 0
Fax: +43 (0) 3136 525 01

For Sales Offices, Distributors and Representatives, please visit:

<http://www.austriamicrosystems.com/contact>