

DO NOT SCALE FROM THIS PRINT

DESIGNED & DIMENSIONED IN MILLIMETERS [INCHES]

SMA-P-C-XX-ST-CA9

GENDER -P: PLUG
 TYPE -C: CABLE
 TERMINATION -CA9: CCA-402-X (RG402 CABLE)
 ORIENTATION -ST: STRAIGHT
 PLATING SPECIFICATION
 -HF: 30µ" GOLD CENTER CONTACT, 3µ" GOLD OUTER CONTACT
 -GF: 10µ" GOLD CENTER CONTACT, 3µ" GOLD OUTER CONTACT
 -GN: 10µ" GOLD CENTER CONTACT, 100µ" NICKEL ON COUPLING NUT, 3µ" NICKEL OUTER CONTACT (SEE TABLE 1)

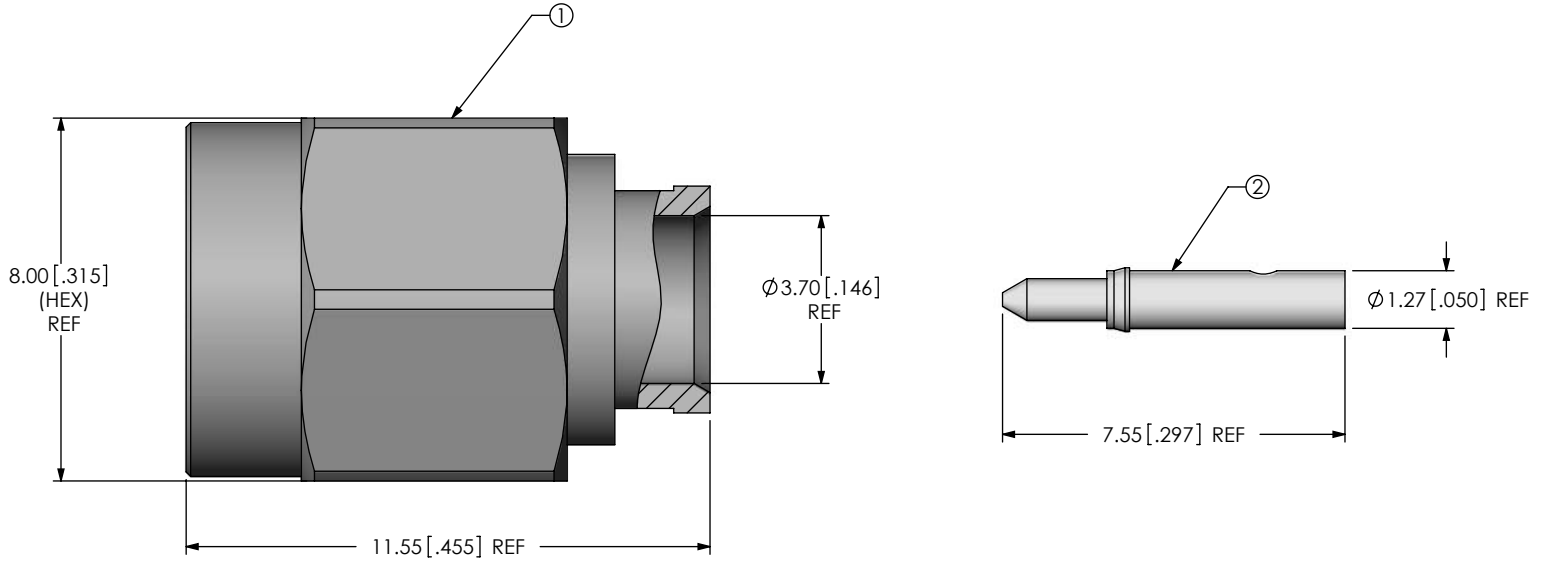



TABLE 1

ITEM	COMPONENT	-HF	-GF	-GN
1	SUB ASSEMBLY	SUB-SMA-P-C-F-ST-CA9	SUB-SMA-P-C-F-ST-CA9	SUB-SMA-P-C-NF-ST-CA9
2	PIN	SMA-PIN-011-H	SMA-PIN-011-G	SMA-PIN-011-G

NOTES:

1. Ⓢ REPRESENTS A CRITICAL DIMENSION.
2. PUSHOUT FORCE FOR CENTER CONTACT: 13.35N [3 LBS] MIN.
3. SEE SHEET 2 FOR TERMINATION INFORMATION.
4. PRODUCT TO BE PACKAGED PER PACKAGING STANDARD CO-RF-WI-3040-M.
5. RoHS COMPLIANT.
6. NOTE DELETED.
7. NOTE DELETED.

UNLESS OTHERWISE SPECIFIED DIMENSIONS ARE IN MILLIMETERS [INCHES] TOLERANCES ARE: DECIMALS ANGLES .X: ±0.3 [.01] 5° .XX: ±0.13 [.005] .XXX: ±0.051 [.0020]	PROPRIETARY NOTE THIS DOCUMENT CONTAINS INFORMATION CONFIDENTIAL AND PROPRIETARY TO SAMTEC, INC. AND SHALL NOT BE REPRODUCED OR TRANSFERRED TO OTHER DOCUMENTS OR DISCLOSED TO OTHERS OR USED FOR ANY PURPOSE OTHER THAN THAT WHICH IT WAS OBTAINED WITHOUT THE EXPRESSED WRITTEN CONSENT OF SAMTEC, INC.	 520 PARK EAST BLVD., NEW ALBANY, IN 47150 PHONE: 812-944-6733 FAX: 812-948-5047 e-Mail: info@SAMTEC.com code 55322	
		MATERIAL: DO NOT SCALE DRAWING SHEET SCALE: 6:1 CABLE BODY, NUT: BRASS CONTACT: BRASS DIELECTRIC: PTFE GASKET: SILICONE RING: STAINLESS STEEL	DESCRIPTION: SMA 50 OHM, STRAIGHT PLUG FOR RG402 DWG. NO. SMA-P-C-XX-ST-CA9
BY: ALVIN W 11/15/2010		SHEET 1 OF 2	



IN PROCESS 1
STRIP AND TIN INNER CONDUCTOR

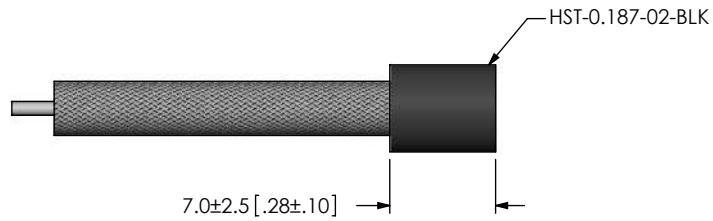

IN PROCESS 2
ADD HEAT SHRINK TUBE

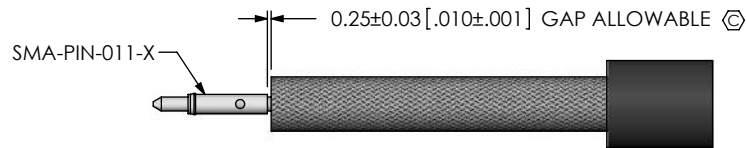

IN PROCESS 3
SOLDER SIGNAL PIN

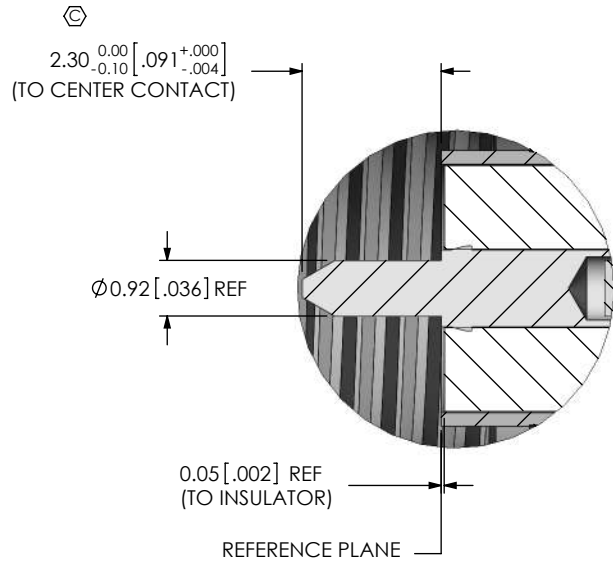

DETAIL 'B'
SCALE 8 : 1

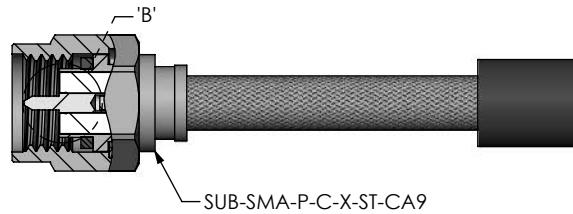

IN PROCESS 4
ADD SUB-SMA-P-C-X-ST-CA9



IN PROCESS 5
SOLDER SUB ASSEMBLY

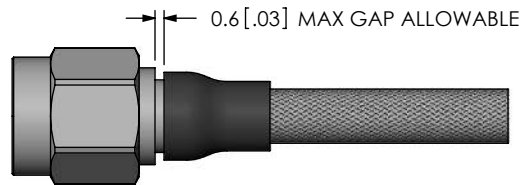

IN PROCESS 6
APPLY HEAT SHRINK TUBING

PROPRIETARY NOTE

THIS DOCUMENT CONTAINS INFORMATION CONFIDENTIAL AND PROPRIETARY TO SAMTEC, INC. AND SHALL NOT BE REPRODUCED OR TRANSFERRED TO OTHER DOCUMENTS OR DISCLOSED TO OTHERS OR USED FOR ANY PURPOSE OTHER THAN THAT WHICH IT WAS OBTAINED WITHOUT THE EXPRESSED WRITTEN CONSENT OF SAMTEC, INC.

DO NOT SCALE DRAWING

SHEET SCALE: 2:1

samtec

520 PARK EAST BLVD, NEW ALBANY, IN 47150
PHONE: 812-944-6733 FAX: 812-948-5047
e-Mail: info@SAMTEC.com code 55322

DESCRIPTION:
SMA 50 OHM, STRAIGHT PLUG FOR RG402

DWG. NO.
SMA-P-C-XX-ST-CA9

BY: ALVIN W 11/15/2010 SHEET 2 OF 2