

REVISIONS					
REV	DATE	DESCRIPTION	BY	CHK	APP'D
B1	02NOV2021	REVISED PER ECR-21-119230	SS	VS	

- PARTS COMPLY WITH AMP SOLDERABILITY SPECIFICATION 109-11-5.
- TOLERANCE NON-CUMULATIVE.
- CIRCUIT IDENTIFICATION CHARACTERS ARE ADJACENT TO THE INDICATED CAVITIES, BUT LOCATION AND ORIENTATION MAY DIFFER FROM PRINT.
- DIMENSIONS IN BRACKETS ARE IN INCHES.
- FLAMMABILITY V2 FOR THICKNESS 0.38mm, 1.5mm, and 3.0mm PER IEC 60695-11-10.
- GLOW-WIRE FLAMMABILITY (GWFI) 800°C FOR THICKNESS 0.38mm AND 0.75mm PER IEC 60695-2-12.
- GLOW-WIRE FLAMMABILITY (GWFI) 960°C FOR THICKNESS 1.5mm AND 3.0mm PER IEC 60695-2-12.
- GLOW-WIRE IGNITION (GWIT) 825°C FOR THICKNESS 0.38mm, 0.75mm, 1.5mm AND 3.0mm PER IEC 60695-2-13.
- DIMENSIONS SHOWN REPRESENT PRODUCT IN DRY CONDITION. ADDITIONAL 2% GROWTH DUE TO END USE LOCATION MOISTURE ABSORPTION MAY OCCUR AND SHOULD BE ACCOUNTED FOR.

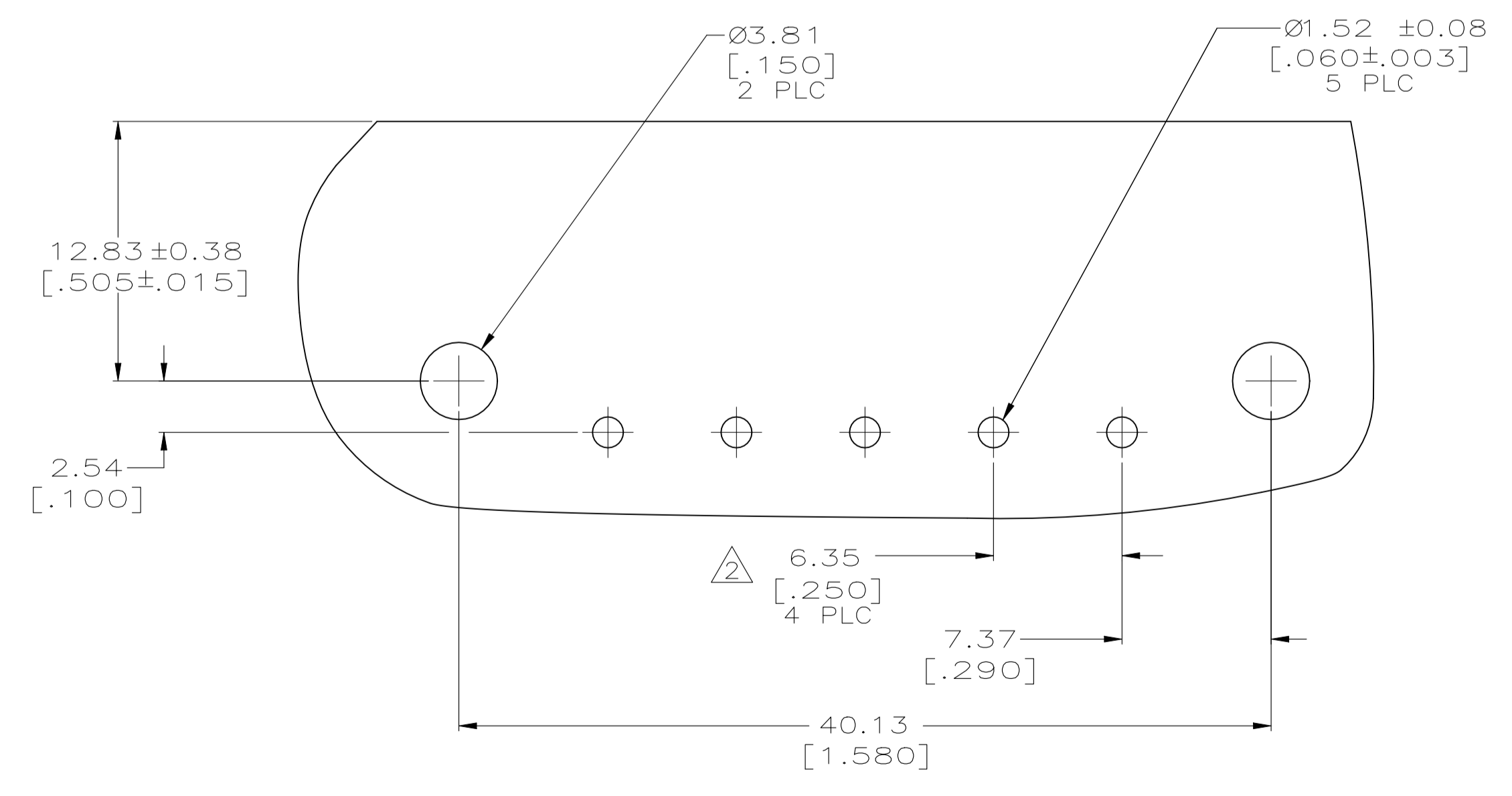

RECOMMENDED MOUNTING HOLE PATTERN FOR .062 [1.57] THICK P.C. BOARD

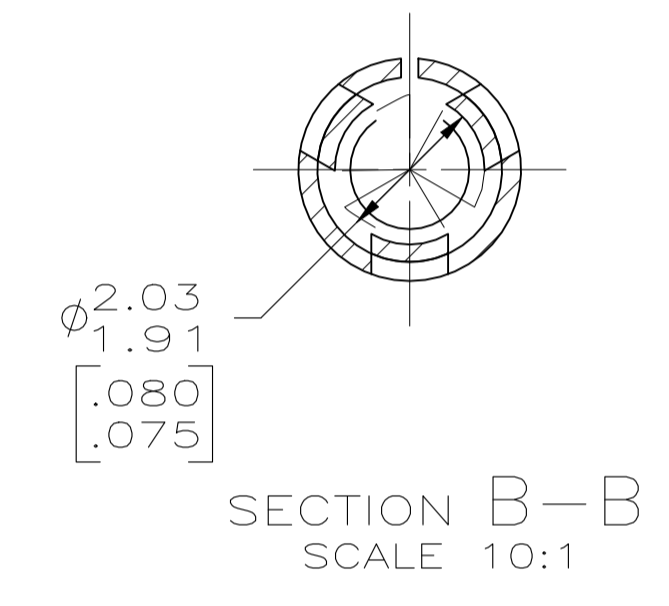
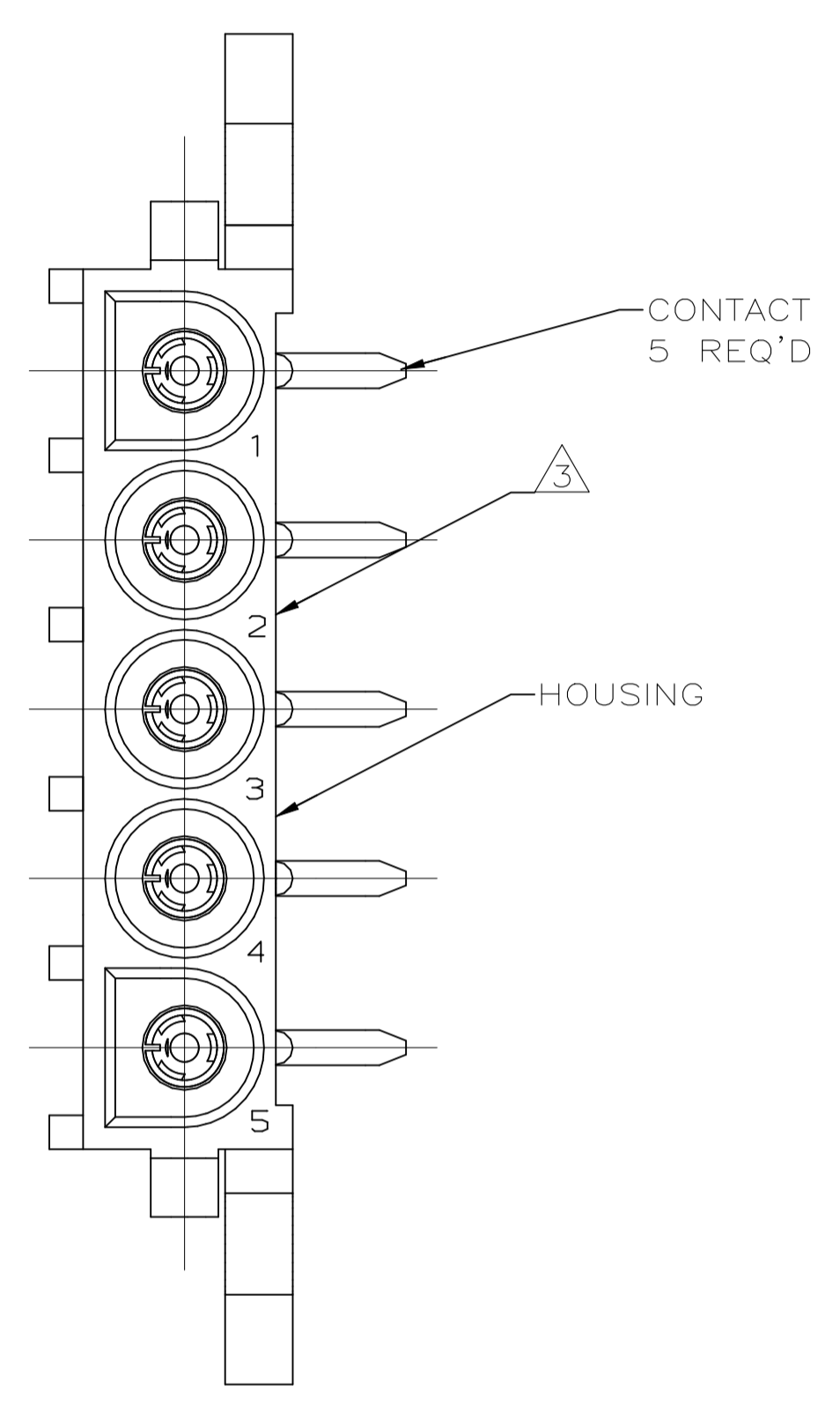
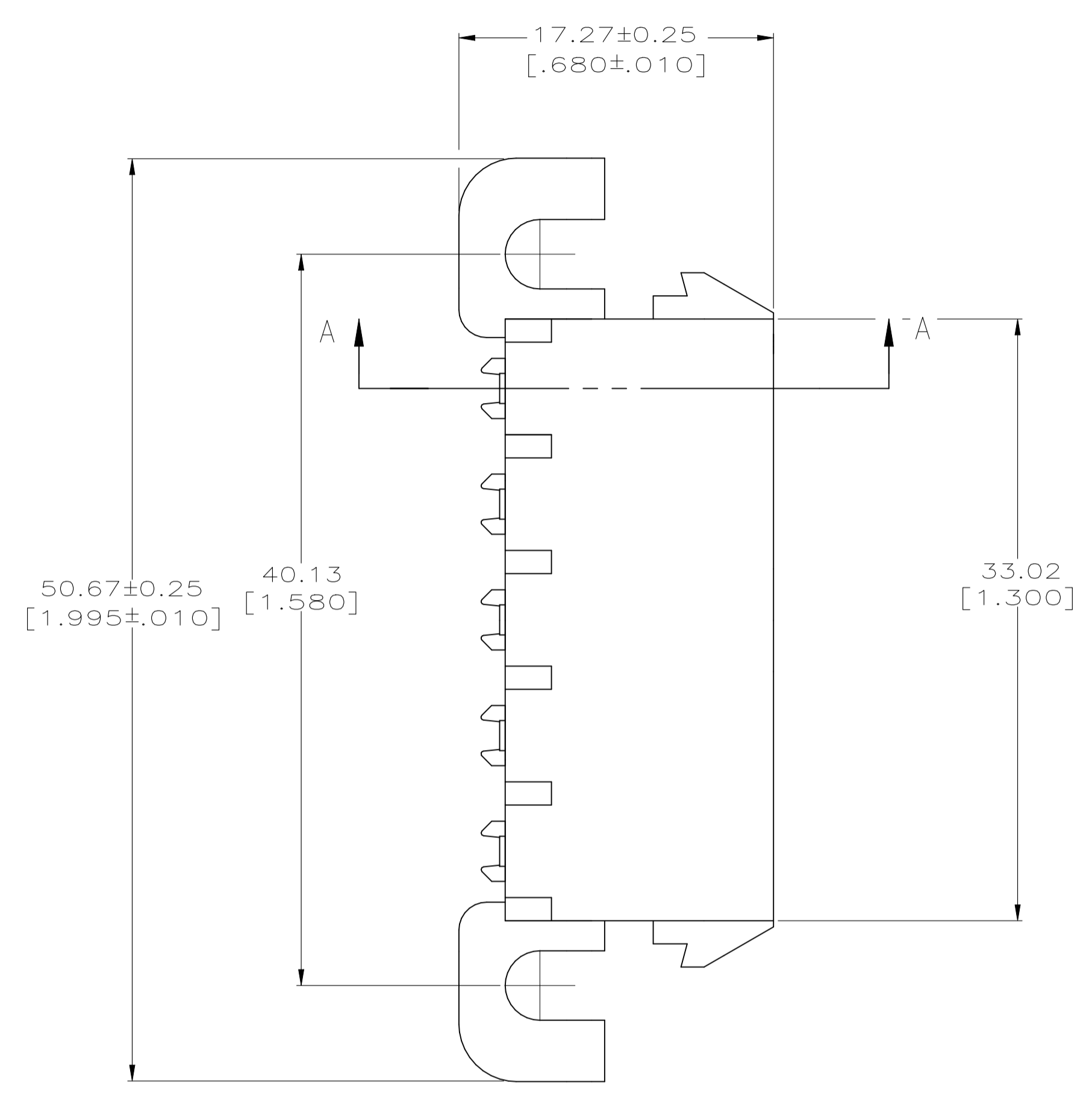
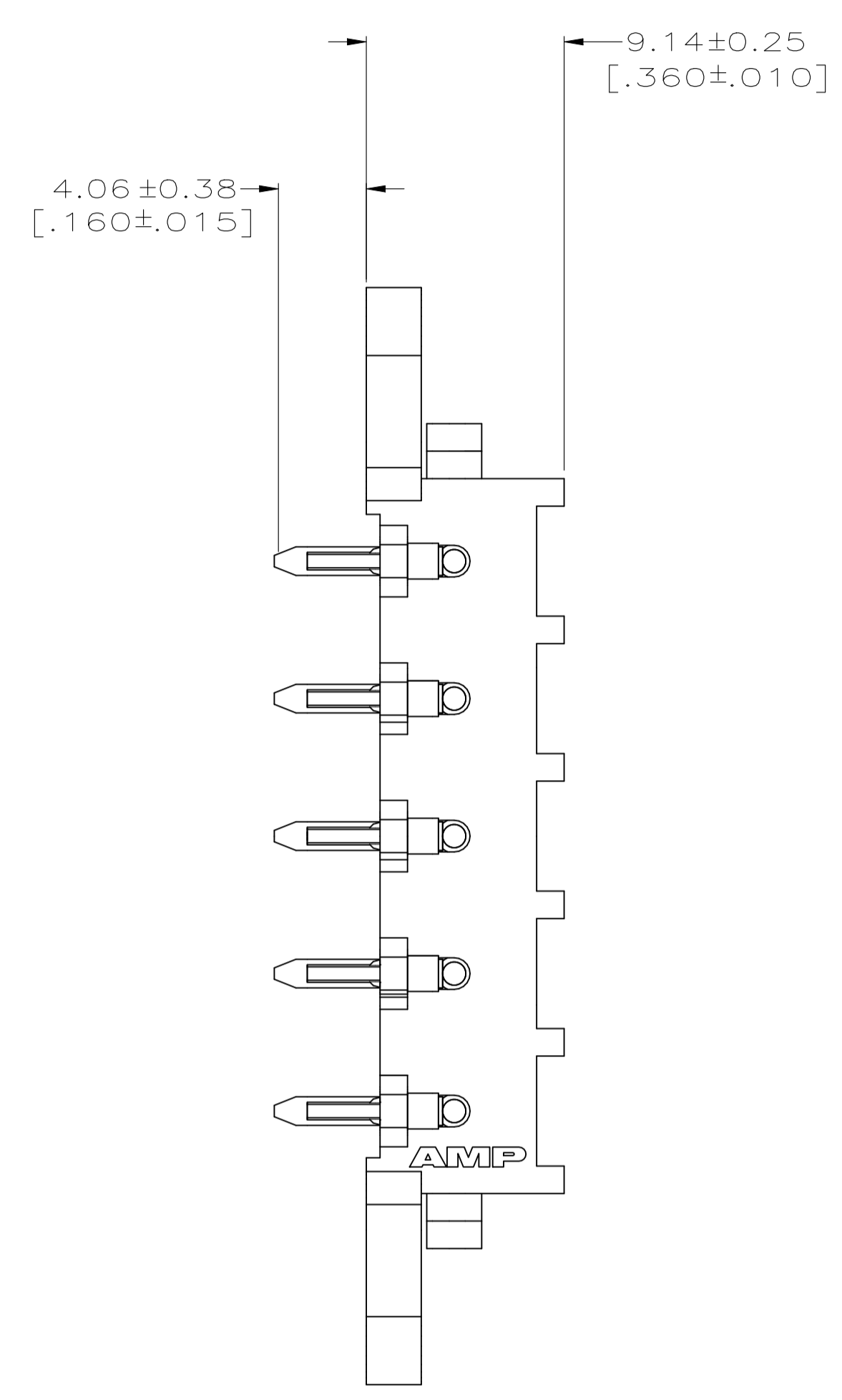
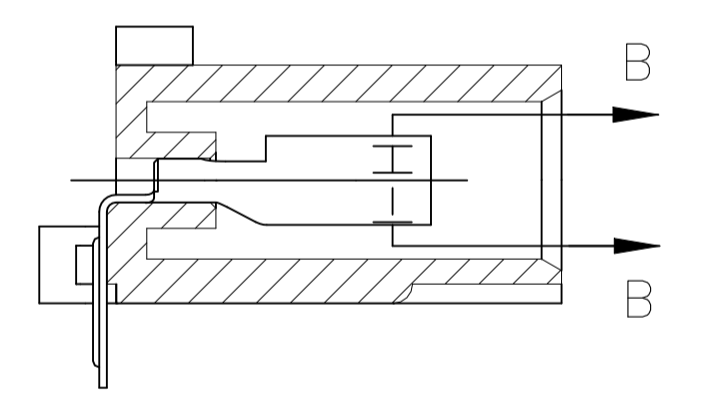
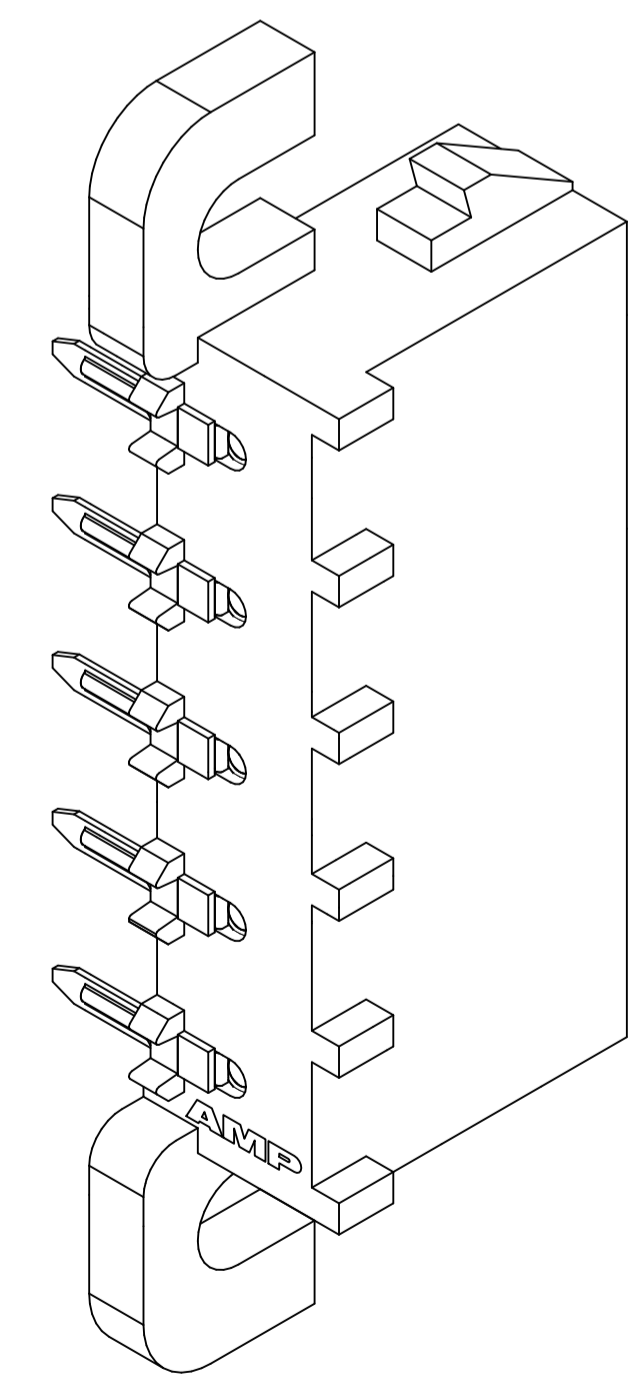

SECTION A-A

PH BRZ PRE-TIN	NYLON UL 94V-2	1586899-1
CONTACT	HOUSING	PART NUMBER

THIS DRAWING IS A CONTROLLED DOCUMENT.		DIN K. WHITAKER 14MAR2008	TE Connectivity
DIMENSIONS: mm [INCHES]		CHK D. COLEY 14MAR2008	
TOLERANCES UNLESS OTHERWISE SPECIFIED:		APP'D D. COLEY 14MAR2008	NAME
0 PLC ± -	1 PLC ± -	PRODUCT SPEC	SOCKET HEADER ASSEMBLY, RIGHT ANGLE MOUNT, 5 POSITION, UNIVERSAL MATE-N-LOK(TM)
2 PLC ± 0.13[.005]	3 PLC ± -	APPLICATION SPEC	SIZE
4 PLC ± -	ANGLES ± -	FINISH	CAGE CODE
MATERIAL SEE TABLE	FINISH SEE TABLE	WEIGHT 0.000000	DRAWING NO. A100779
		CUSTOMER DRAWING	REV B1

