

REVISIONS		
LTR	DESCRIPTION	DATE
C	REVISED PER ECD-08-021113	08/26/2008

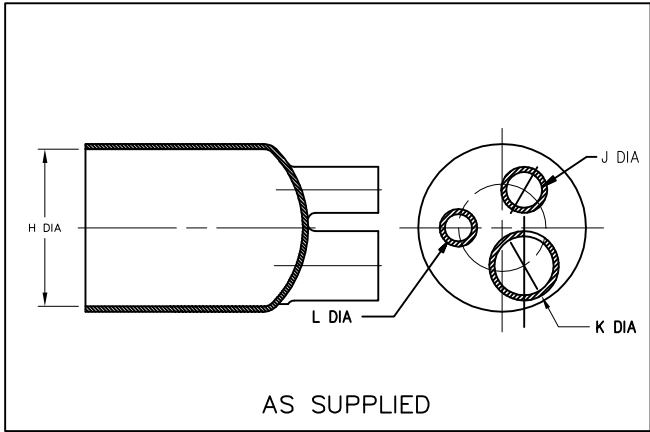

AS SUPPLIED

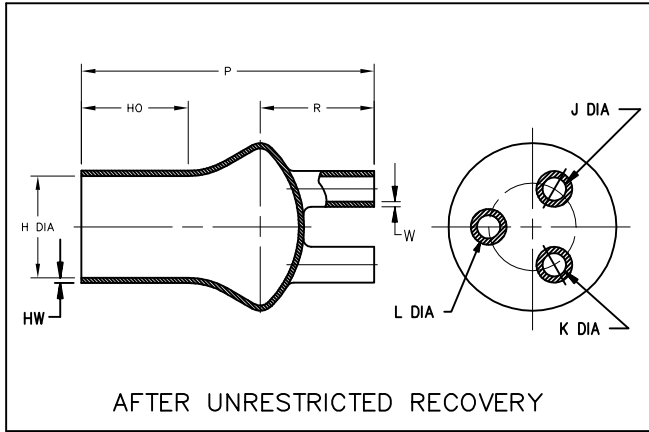

AFTER UNRESTRICTED RECOVERY

PART DESCRIPTION	H		J		K		L		P	R	HO	W	HW	WEIGHT
	MIN	MAX	MIN	MAX	MIN	MAX	MIN	MAX	±10%	±10%	±10%	±20%	±20%	REF
	a	b	a	b	a	b	a	b	b	b	b	b	b	b
403A016-X-04	<u>2.42</u> [61,5]	<u>1.74</u> [44,2]	<u>.97</u> [24,6]	<u>.41</u> [10,4]	<u>1.25</u> [31,7]	<u>.41</u> [10,4]	<u>.72</u> [18,3]	<u>.41</u> [10,4]	<u>4.75</u> [120,7]	<u>1.85</u> [47,0]	<u>1.70</u> [43,2]	<u>.10</u> [2,54]	<u>.08</u> [2,03]	<u>.131</u> [59,4]

NOTES:

- ALL DIMENSIONS ARE IN  $\frac{\text{INCHES}}{\text{MILIMETERS}}$   $\frac{\text{lbs}}{\text{[gms]}}$
- DIMENSIONS APPEARING IN TABLE ARE AS FOLLOWS:  
a - AS SUPPLIED  
b - AFTER UNRESTRICTED RECOVERY
- WEIGHT SHOWN IN TABLE OF DIMENSIONS IS BASED ON POLYOLEFIN PART.
- ORDERING INFORMATION:

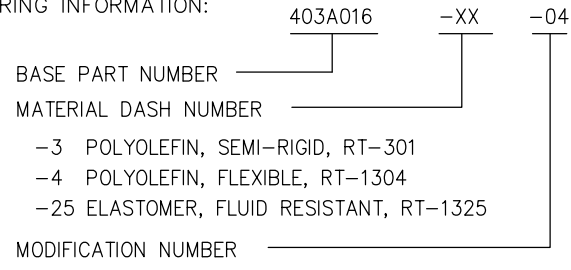

If this document is printed it becomes uncontrolled. Check for the latest revision

CUSTOMER DRAWING

UNLESS OTHERWISE SPECIFIED DIMENSIONS ARE INCHES. METRIC DIMENSIONS ARE IN BRACKETS.	DRAWN	DATE		Raychem Molded Parts 305 Constitution Dr Menlo Park, CA 94025
	UNGUYEN	08/26/2008		
DECIMAL TOLERANCES	RPN	N/A		
.XXX ± 0.005 [0.13 mm]				
.XX ± 0.01 [0.25 mm]				
.X ± 0.1 [0.50 mm]				
ANGLE TOLERANCE	THIRD ANGLE PROJECTION			
.X ± 1 DEG.				
TYCO ELECTRONICS RESERVES THE RIGHT TO AMEND THIS DRAWING AT ANY TIME. USERS SHOULD EVALUATE THE SUITABILITY OF THE PRODUCT FOR THEIR APPLICATION.	SIZE	CODE IDENT. NO.	DWG. NO.	
	B	06090	403A016-X-04	
© 2003-2008 Tyco Electronics Corporation. All rights reserved.	DO NOT SCALE THIS DRAWING		SHEET 1 OF 1	