

2-PAD INDUSTRIAL GRADE CERAMIC RESONATOR



AWSZT-CP SERIES

6.0 x 3.0 x 1.7mm

RoHS/RoHS II Compliant

Pb in ceramic, exemption (7c-1)

MSL = 1

FEATURES

- Low resonant impedance
- IR reflow capable
- Low cost

APPLICATIONS

- Remote controls, microprocessor clocks, mobile phones, DVD & CD-Roms, Electric appliances
- Consumer electronics

STANDARD SPECIFICATIONS

PARAMETERS	MINIMUM	TYPICAL	MAXIMUM	UNITS	NOTES
Frequency Range	2.00		12.00	MHz	
Resonant Impedance (Ro)		100		Ω	2.00 MHz – 2.99 MHz
		50			3.00 MHz – 3.49 MHz
		30			3.50 MHz – 12.00 MHz
Load Capacitance for test circuit (C1=C2)		30		pF	2.00 MHz – 12.00 MHz
Frequency Tolerance	-0.5		0.5	%	
Frequency Stability	-0.3		0.3	%	-25°C TO +85°C
Withstanding Voltage			50	V	DC , 1 min.
Rating Voltage	(1) D.C. Voltage		6	V	
	(2) A.C. Voltage		15	Vp-p.	
Insulation Resistance	100			MΩ	10V, 1 min.
Operation Temperature	-25		+85	°C	
Storage Temperature	-55		+85	°C	
Aging Rate (Fosc)	-0.1		0.1	%	10 years

OPTIONS AND PART IDENTIFICATION (LEFT BLANK IF STANDARD)

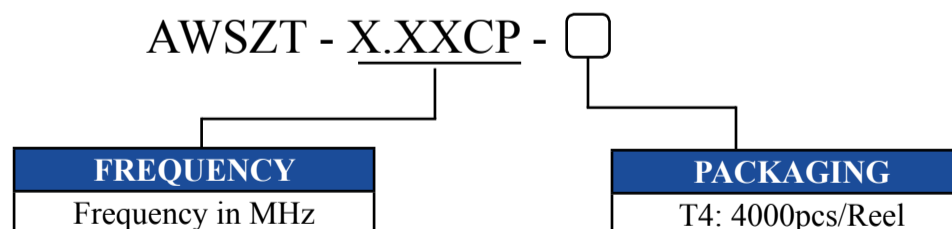

2-PAD INDUSTRIAL GRADE CERAMIC RESONATOR



AWSZT-CP SERIES

6.0 x 3.0 x 1.7mm

RoHS/RoHS II Compliant

Pb in ceramic, exemption (7c-1)

MSL = 1

OUTLINE DIMENSIONS

TOP VIEW

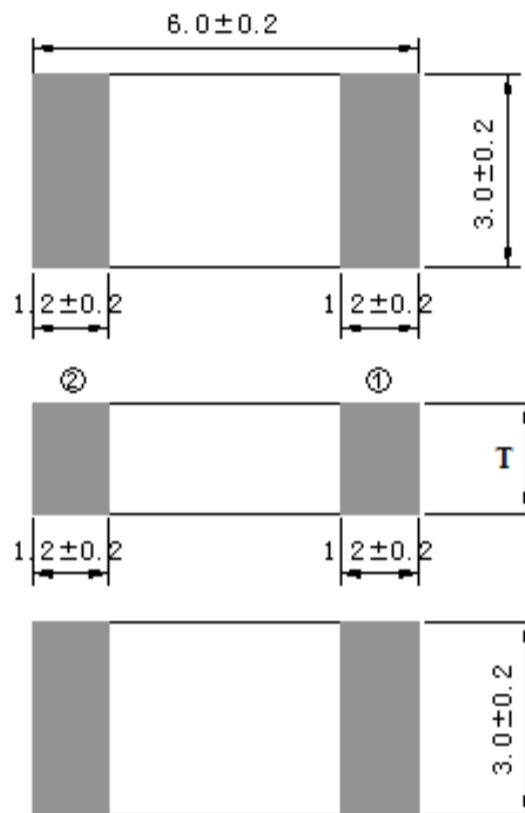

T=1.7±0.2mm(2.00-3.99MHz)
T=1.4±0.2mm(4.00-12.00MHz)

① Input
② Output

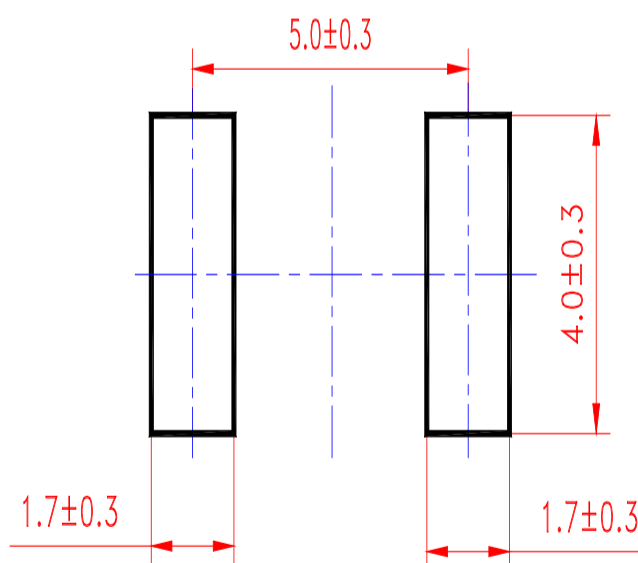

RECOMMENDED LANDING PATTERN (mm)

2-PAD INDUSTRIAL GRADE CERAMIC RESONATOR



6.0 x 3.0 x 1.7mm

RoHS/RoHS II Compliant

Pb in ceramic, exemption (7c-1)

MSL = 1

AWSZT-CP SERIES

REFLOW

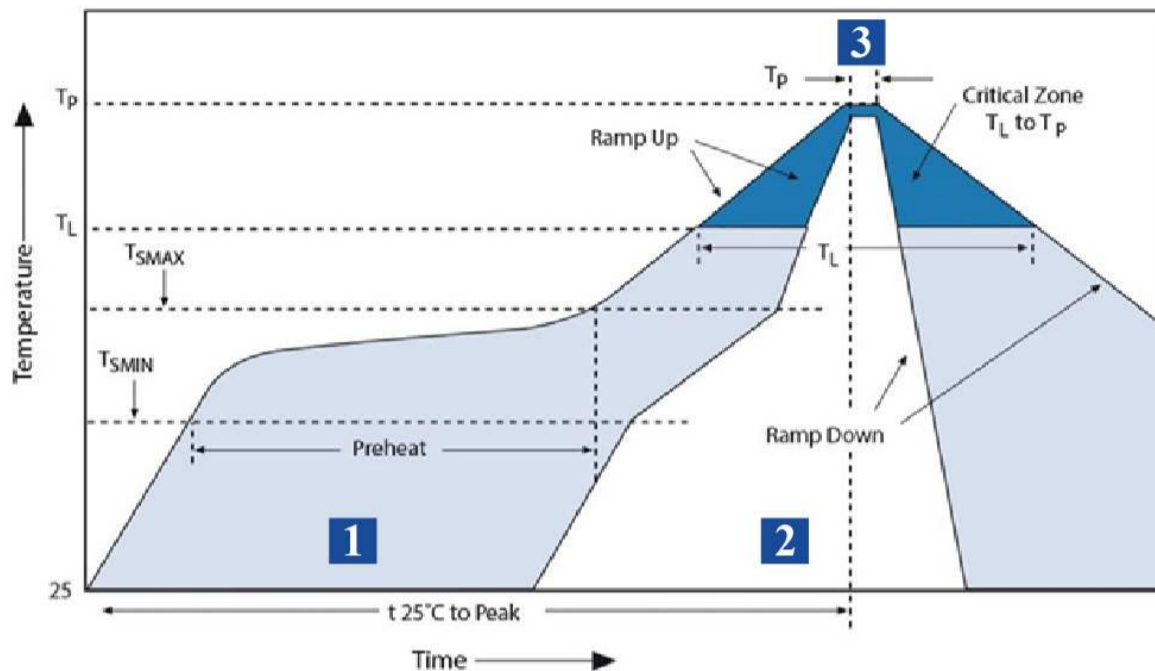

Zone	Description	Temperature	Times
1	Preheat	$T_{SMIN} \sim T_{SMAX}$ 150°C ~ 180°C	80~120 sec.
2	Reflow	T_L 230 °C	20~40 sec.
3	Peak Heat	T_P 260 °C	10 sec. MAX

TAPE AND REEL

PACKAGING: T4: 4000PCS/REEL

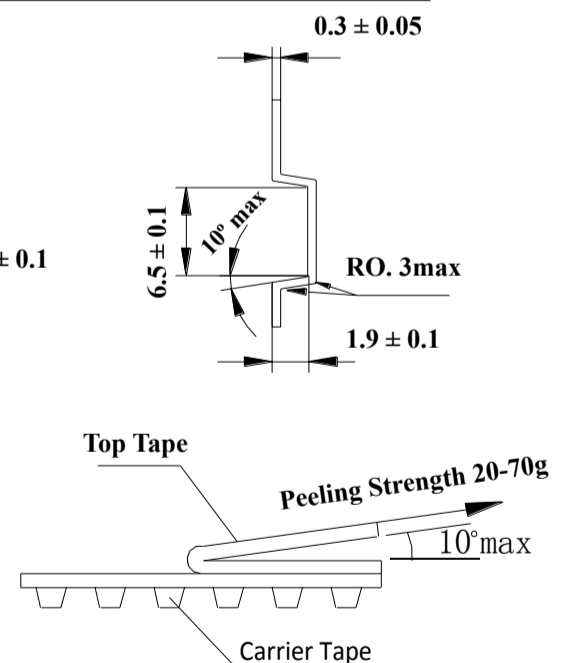
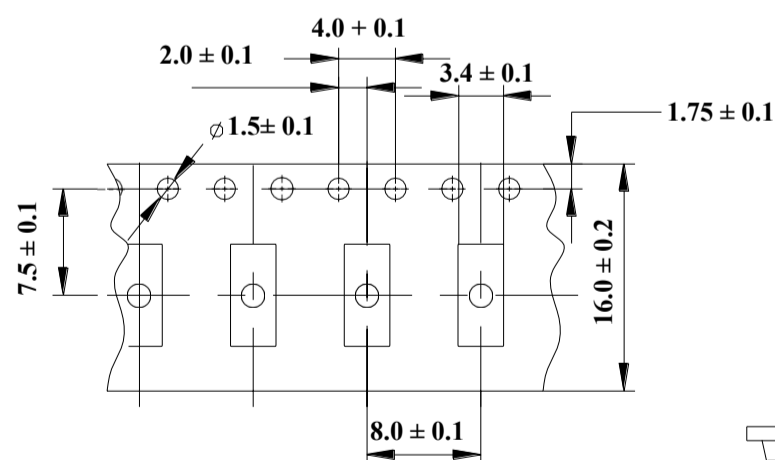
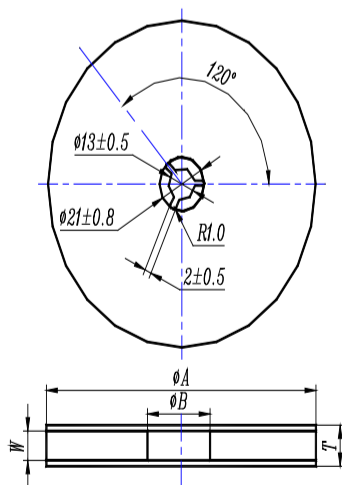

ϕA	ϕB	W	T	Pieces per reel	Carrier tape size
330±3	80min	16.4min	22.4max	4000typ.	16

REVISED: 12.19.2016



5101 Hidden Creek Ln Spicewood TX 78669
 Phone: 512-371-6159 | Fax: 512-351-8858
 For terms and conditions of sales, please visit:
www.abracon.com

ABRACON IS
 ISO9001-2008
 CERTIFIED

2-PAD INDUSTRIAL GRADE CERAMIC RESONATOR



AWSZT-CP SERIES

6.0 x 3.0 x 1.7mm

RoHS/RoHS II Compliant

Pb in ceramic, exemption (7c-1)

MSL = 1

CAUTION

1. Don't apply excess mechanical stress to the component and terminals at soldering. Do not use this product with bend.
2. Do not clean or wash the component for it is not hermetically sealed.
3. Do not use strong acidity flux, more than 0.2wt% chlorine content, in flow soldering.
4. Don't be close to fire.
5. This specification mentions the quality of the component as a single unit. Please insure the component is thoroughly evaluated in your application circuit
6. Expire date (Shelf life) of the products is 12 months after delivery under the conditions of a sealed and an unopened package. Please use the products within 12 months after delivery. If you store the products for a long time (more than 12 months), use carefully because the products may be degraded in the solderability or rusty. Please confirm solderability and characteristics for the products regularly.

NOTES

1. The parts are manufactured in accordance with this specification. If other conditions and specifications which are required for this specification, please contact ABRACON for more information.
2. ABRACON will supply the parts in accordance with this specification unless we receive a written request to modify prior to an order placement.
3. In no case shall ABRACON be liable for any product failure from in appropriate handling or operation of the item beyond the scope of this specification.
4. When changing your production process, please notify ABRACON immediately.
5. ABRACON's products are COTS – Commercial-Off-The-Shelf products; suitable for Commercial, Industrial and, where designated, Automotive Applications. ABRACON's products are not specifically designed for Military, Aviation, Aerospace, Life-dependant Medical applications or any application requiring high reliability where component failure could result in loss of life and/or property. For applications requiring high reliability and/or presenting an extreme operating environment, written consent and authorization from ABRACON is required. Please contact ABRACON for more information.
6. All specifications and Marking will be subject to change without notice.