

2-Bit Bi-directional Level Shifter with Automatic Sensing & Ultra Tiny Package

Features

- V_{CCA} can be Less than, Greater than or Equal to V_{CCB}
- 1.2V to 5.5V on A Port and 1.2V to 5.5V on B Port
- High-Speed with 20 Mb/s Data Rate for push-pull application
- High-Speed with 2 Mb/s Data Rate for open-drain application
- No Direction-Control Signal Needed
- Low Bit-to-Bit Skew
- Non-preferential Power-up Sequencing
- ESD protection exceeds 8KV HBM per JESD22-A114
- Integrated 10 kΩ Pull-up Resistors
- Totally Lead-Free & Fully RoHS Compliant (Notes 1 & 2)
- Halogen and Antimony Free. "Green" Device (Note 3)
- For automotive applications requiring specific change control (i.e. parts qualified to AEC-Q100/101/200, PPAP capable, and manufactured in IATF 16949 certified facilities), please [contact us](mailto:contact_us) or your local Diodes representative.
- <https://www.diodes.com/quality/product-definitions/>
- Packaging (Pb-free & Green):
 - 8-UDFN1.2x1.6(XV)
 - 8-MSOP (U)

Applications

- I2C, SMBus, MDIO
- Low Voltage ASIC Level Translation
- Mobile Phones, PDAs, Camera

Description

The PI4ULS5V202 is a 2-bit configurable dual supply bidirectional auto sensing translator that does not require a directional control pin. The A and B ports are designed to track two different power supply rails, V_{CCA} and V_{CCB} respectively. Both the V_{CCA} and V_{CCB} supply rails are configurable from 1.2V to 5.5V. This allows voltage logic signals on the V_{CCA} side to be translated into lower, higher or equal value voltage logic signals on the V_{CCB} side, and vice-versa.

The translator has integrated 10 kΩ pull-up resistors on the I/O lines. The integrated pull-up resistors are used to pull-up the I/O lines to either V_{CCA} or V_{CCB} . The PI4ULS5V202 is an excellent match for open-drain applications such as the I²C communication bus.

Block Diagram

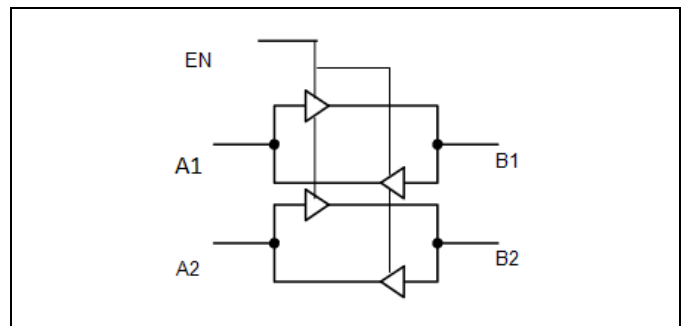
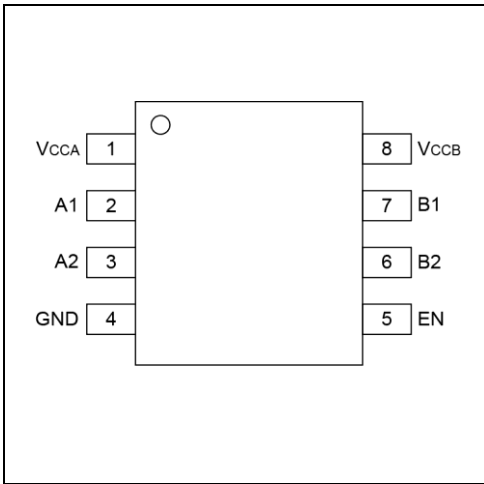

Figure 1: Block Diagram

Notes:
 1. No purposely added lead. Fully EU Directive 2002/95/EC (RoHS), 2011/65/EU (RoHS 2) & 2015/863/EU (RoHS 3) compliant.
 2. See <https://www.diodes.com/quality/lead-free/> for more information about Diodes Incorporated's definitions of Halogen- and Antimony-free, "Green" and Lead-free.
 3. Halogen- and Antimony-free "Green" products are defined as those which contain <900ppm bromine, <900ppm chlorine (<1500ppm total Br + Cl) and <1000ppm antimony compounds.

Pin Configuration



MSOP-8

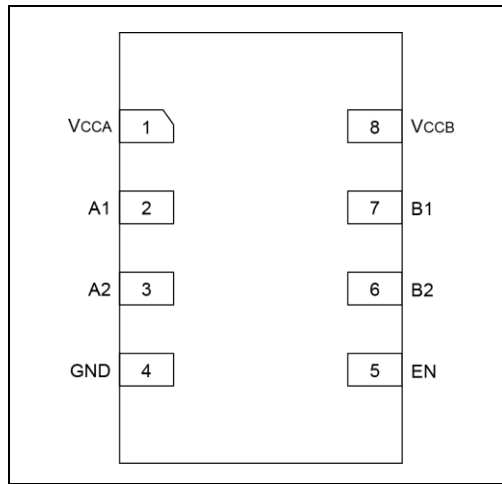

UDFN-8

Pin Description

Pin#	Pin Name	Type	Description
1	V _{CCA}	Power	A-port supply voltage. $1.2V \leq V_{CCA} \leq 5.5V$
2	A1	I/O	Input/output A. Referenced to V _{CCA} .
3	A2	I/O	Input/output A. Referenced to V _{CCA}
4	GND	GND	Ground.
5	EN	Input	Output enable (active High). Pull EN low to place all outputs in 3-state mode.
6	B2	I/O	Input/output B. Referenced to V _{CCB}
7	B1	I/O	Input/output B. Referenced to V _{CCB}
8	V _{CCB}	Power	B-port supply voltage. $1.2V \leq V_{CCB} \leq 5.5V$

Maximum Ratings

Storage Temperature.....	-65°C to +150°C
DC Supply Voltage port B.....	-0.3V to +5.5V
DC Supply Voltage port A.....	-0.3V to +5.5V
Vi(A) referenced DC Input / Output Voltage.....	-0.3V to +5.5V
Vi(B) referenced DC Input / Output Voltage.....	-0.3V to +5.5V
Enable Control Pin DC Input Voltage.....	-0.3V to +5.5V
Short circuit duration (I/O to GND).....	40mA

Note:

Stresses greater than those listed under MAXIMUM RATINGS may cause permanent damage to the device. This is a stress rating only and functional operation of the device at these or any other conditions above those indicated in the operational sections of this specification is not implied. Exposure to absolute maximum rating conditions for extended periods may affect reliability.

Recommended Operation Conditions

Symbol	Parameter	Min	Typ	Max	Unit
V _{CCA}	V _{CCA} Positive DC Supply Voltage	1.2	-	5.5	V
V _{CCB}	V _{CCB} Positive DC Supply Voltage	1.2	-	5.5	V
V _{EN}	Enable Control Pin Voltage	GND	-	5.5	V
V _{IO}	I/O Pin Voltage	GND	-	5.5	V
T _A	Operating Temperature Range	-40	-	+85	°C

DC Electrical Characteristics

Unless otherwise specified, -40°C ≤ T_A ≤ 85°C, 1.2V ≤ V_{CC} ≤ 5.5V

Symbol	Parameter	Test Conditions	Min	Typ	Max	Unit
V _{IHB}	B port Input HIGH Voltage	-	V _{CCB} - 0.2	-	-	V
V _{ILB}	B port Input LOW Voltage	-	-	-	0.15	V
V _{IHA}	A port Input HIGH Voltage	-	V _{CCA} - 0.2	-	-	V
V _{ILA}	A port Input LOW Voltage	-	-	-	0.15	V
V _{IH}	Control Pin Input HIGH Voltage	-	V _{CCA} - 0.2	-	-	V
V _{IL}	Control Pin Input LOW Voltage	-	-	-	0.15	V
V _{OHB}	B port Output HIGH Voltage	B port source current = -20 μA	2/3 * V _{CCB}	-	-	V
V _{OLB}	B port Output LOW Voltage	B port sink current = 1 mA	-	-	1/3 * V _{CCB}	V
V _{OHA}	A port Output HIGH Voltage	A port source current = -20 μA	2/3 * V _{CCA}	-	-	V
V _{OLA}	A port Output LOW Voltage	A port sink current = 1 mA	-	-	1/3 * V _{CCA}	V
I _{QVCB}	V _{CCB} Supply Current	B port and A port unconnected, V _{EN} = V _{CCA}	-	0.5	5.0	μA
I _{QVCA}	V _{CCA} Supply Current	B port and A port unconnected, V _{EN} = V _{CCA}	-	0.3	5.0	μA
I _{TS-V_{CCB}}	B Tri-state Output Mode	B port and A port unconnected, V _{EN} = GND	-	0.1	1	μA
I _{TS-V_{CCA}}	A Tri-state Output Mode Supply Current	B port and A port unconnected, V _{EN} = GND	-	0.1	1	μA
I _{OZ}	I/O Tri-state Output Mode Leakage Current		-	0.1	1.0	μA
R _{PU}	Pull-Up Resistors I/O A and B		-	10	-	kΩ

Note: All units are production tested at T_A = +25°C. Limits over the operating temperature range are guaranteed by design.

Typical values are for V_{CCB} = +2.8 V, V_{CCA} = +1.8 V and T_A = +25°C.

AC Electrical Characteristics

Timing Characteristics – Rail-to-Rail Driving Configuration

(I/O test circuits of Figures 2, 3 and 7, $C_{LOAD} = 15\text{ pF}$, driver output impedance $\leq 50\Omega$, $R_{LOAD} = 1\text{ M}\Omega$, unless otherwise specified)

Symbol	Parameter	Test Conditions	Min	Typ	Max	Unit
$V_{CCA} = 1.8\text{V}$, $V_{CCB} = 2.8\text{V}$						
t_{RB}	B port Rise Time	-	-	-	15	nS
t_{FB}	B port Fall Time	-	-	-	15	nS
t_{RA}	A port Rise Time	-	-	-	25	nS
t_{FA}	A port Fall Time	-	-	-	10	nS
$t_{PHL-A-B}$	Propagation Delay (Driving A)	-	-	-	15	nS
$t_{PLH-A-B}$		-	-	-	15	nS
$t_{PHL-B-A}$	Propagation Delay (Driving B)	-	-	-	15	nS
$t_{PLH-B-A}$		-	-	-	15	nS
t_{PPSKEW}	Part-to-Part Skew	-	-	-	5	nS
MDR	Maximum Data Rate	-	20	-	-	Mbps
$V_{CCA} = 2.8\text{V}$, $V_{CCB} = 1.8\text{V}$						
t_{RB}	B port Rise Time	-	-	-	25	nS
t_{FB}	B port Fall Time	-	-	-	10	nS
t_{RA}	A port Rise Time	-	-	-	20	nS
t_{FA}	A port Fall Time	-	-	-	15	nS
$t_{PHL-A-B}$	Propagation Delay (Driving A)	-	-	-	15	nS
$t_{PLH-A-B}$		-	-	-	15	nS
$t_{PHL-B-A}$	Propagation Delay (Driving B)	-	-	-	15	nS
$t_{PLH-B-A}$		-	-	-	15	nS
t_{PPSKEW}	Part-to-Part Skew	-	-	-	5	nS
MDR	Maximum Data Rate	-	20	-	-	Mbps
$V_{CCA} = 2.5\text{V}$, $V_{CCB} = 3.6\text{V}$						
t_{RB}	B port Rise Time	-	-	-	15	nS
t_{FB}	B port Fall Time	-	-	-	10	nS
t_{RA}	A port Rise Time	-	-	-	15	nS
t_{FA}	A port Fall Time	-	-	-	10	nS
$t_{PHL-A-B}$	Propagation Delay (Driving A)	-	-	-	15	nS
$t_{PLH-A-B}$		-	-	-	15	nS
$t_{PHL-B-A}$	Propagation Delay (Driving B)	-	-	-	15	nS
$t_{PLH-B-A}$		-	-	-	15	nS
t_{PPSKEW}	Part-to-Part Skew	-	-	-	5	nS
MDR	Maximum Data Rate	-	20	-	-	Mbps
$V_{CCA} = 3.6\text{V}$, $V_{CCB} = 2.5\text{V}$						
t_{RB}	B port Rise Time	-	-	-	15	nS
t_{FB}	B port Fall Time	-	-	-	10	nS
t_{RA}	A port Rise Time	-	-	-	15	nS
t_{FA}	A port Fall Time	-	-	-	15	nS
$t_{PHL-A-B}$	Propagation Delay (Driving A)	-	-	-	15	nS
$t_{PLH-A-B}$		-	-	-	15	nS
$t_{PHL-B-A}$	Propagation Delay	-	-	-	15	nS

Symbol	Parameter	Test Conditions	Min	Typ	Max	Unit
$t_{PLH-B-A}$	(Driving B)	-	-	-	15	nS
t_{PPSKEW}	Part-to-Part Skew	-	-	-	5	nS
MDR	Maximum Data Rate	-	20	-	-	Mbps
$V_{CCA} = 1.5V, V_{CCB} = 5.5V$						
t_{RB}	B port Rise Time	-	-	-	15	nS
t_{FB}	B port Fall Time	-	-	-	20	nS
t_{RA}	A port Rise Time	-	-	-	30	nS
t_{FA}	A port Fall Time	-	-	-	10	nS
$t_{PHL-A-B}$	Propagation Delay (Driving A)	-	-	-	20	nS
$t_{PLH-A-B}$		-	-	-	20	nS
$t_{PHL-B-A}$	Propagation Delay (Driving B)	-	-	-	20	nS
$t_{PLH-B-A}$		-	-	-	20	nS
t_{PPSKEW}	Part-to-Part Skew	-	-	-	5	nS
MDR	Maximum Data Rate	-	20	-	-	Mbps
$V_{CCA} = 5.5, V_{CCB} = 1.5V$						
t_{RB}	B port Rise Time	-	-	-	30	nS
t_{FB}	B port Fall Time	-	-	-	20	nS
t_{RA}	A port Rise Time	-	-	-	15	nS
t_{FA}	A port Fall Time	-	-	-	40	nS
$t_{PHL-A-B}$	Propagation Delay (Driving A)	-	-	-	20	nS
$t_{PLH-A-B}$		-	-	-	20	nS
$t_{PHL-B-A}$	Propagation Delay (Driving B)	-	-	-	20	nS
$t_{PLH-B-A}$		-	-	-	20	nS
t_{PPSKEW}	Part-to-Part Skew	-	-	-	5	nS
MDR	Maximum Data Rate	-	20	-	-	Mbps
$V_{CCA} = 1.2V, V_{CCB} = 5.5V$						
t_{RB}	B port Rise Time	-	-	-	15	nS
t_{FB}	B port Fall Time	-	-	-	30	nS
t_{RA}	A port Rise Time	-	-	-	30	nS
t_{FA}	A port Fall Time	-	-	-	15	nS
$t_{PHL-A-B}$	Propagation Delay (Driving A)	-	-	-	20	nS
$t_{PLH-A-B}$		-	-	-	15	nS
$t_{PHL-B-A}$	Propagation Delay (Driving B)	-	-	-	15	nS
$t_{PLH-B-A}$		-	-	-	15	nS
t_{PPSKEW}	Part-to-Part Skew	-	-	-	5	nS
MDR	Maximum Data Rate	-	20	-	-	Mbps
$V_{CCA} = 5.5V, V_{CCB} = 1.2V$						
t_{RB}	B port Rise Time	-	-	-	30	nS
t_{FB}	B port Fall Time	-	-	-	15	nS
t_{RA}	A port Rise Time	-	-	-	15	nS
t_{FA}	A port Fall Time	-	-	-	30	nS
$t_{PHL-A-B}$	Propagation Delay (Driving A)	-	-	-	15	nS
$t_{PLH-A-B}$		-	-	-	15	nS

Symbol	Parameter	Test Conditions	Min	Typ	Max	Unit
$t_{PHL-B-A}$	Propagation Delay (Driving B)	-	-	-	20	nS
$t_{PLH-B-A}$		-	-	-	15	nS
t_{PPSKEW}	Part-to-Part Skew	-	-	-	5	nS
MDR	Maximum Data Rate	-	20	-	-	Mbps

Timing Characteristics – Open Drain Driving Configuration

(I/O test circuits of Figures 4, 5 and 7, $C_{LOAD} = 15\text{ pF}$, driver output impedance $\leq 50\Omega$, $R_{LOAD} = 1\text{ M}\Omega$, unless otherwise specified)

Symbol	Parameter	Test Conditions	Min	Typ	Max	Unit
$1.2 \leq V_{CCA} \leq V_{CCB} \leq 5.5V$						
t_{RB}	B port Rise Time	-	-	-	450	nS
t_{FB}	B port Fall Time	-	-	-	30	nS
t_{RA}	A port Rise Time	-	-	-	450	nS
t_{FA}	A port Fall Time	-	-	-	30	nS
$t_{PHL-A-B}$	Propagation Delay (Driving A)	-	-	-	300	nS
$t_{PLH-A-B}$		-	-	-	300	nS
$t_{PHL-B-A}$	Propagation Delay (Driving B)	-	-	-	300	nS
$t_{PLH-B-A}$		-	-	-	300	nS
t_{PPSKEW}	Part-to-Part Skew	-	-	-	50	nS
MDR	Maximum Data Rate	-	2	-	-	Mbps

Test Circuits

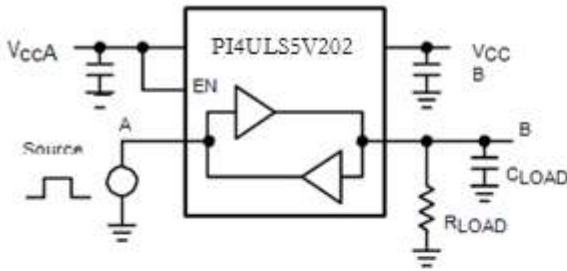

Figure 2. Rail-to-Rail Driving A

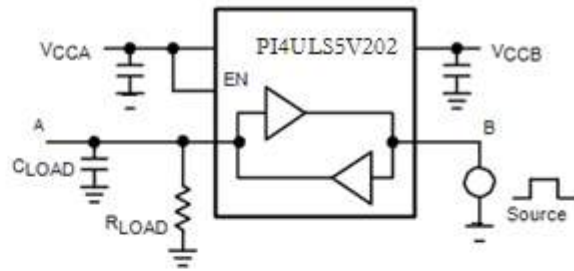

Figure 3. Rail-to-Rail Driving B

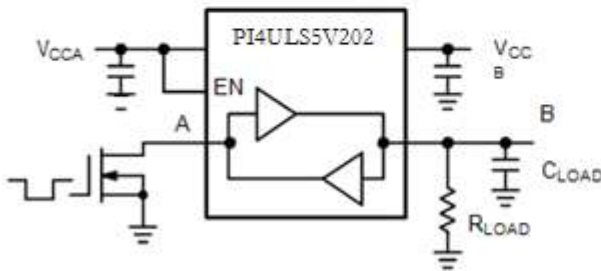

Figure 4. Open-Drain Driving A

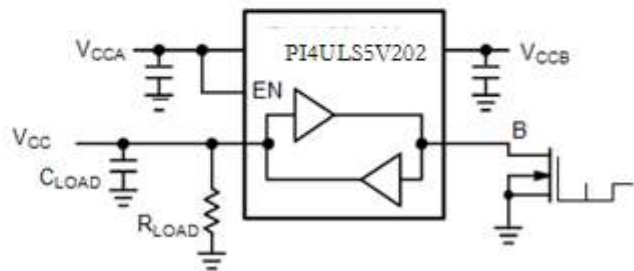

Figure 5. Open-Drain Driving B

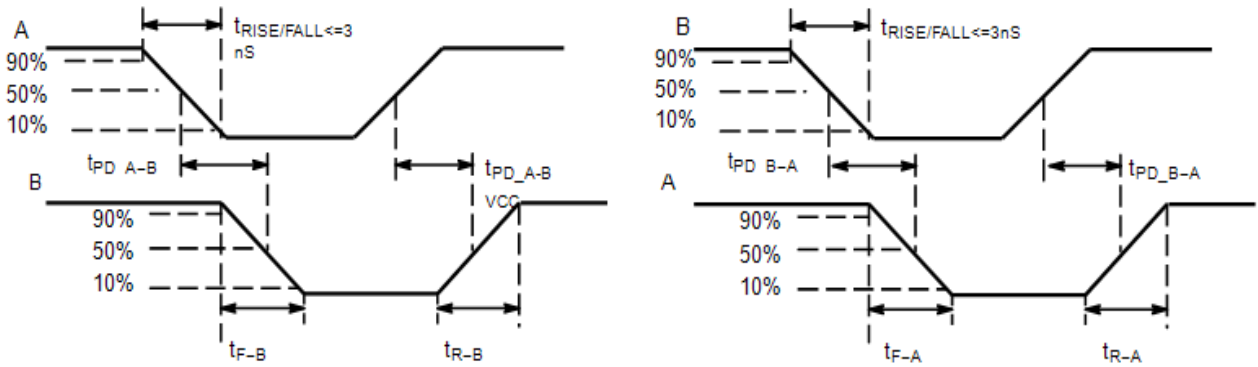
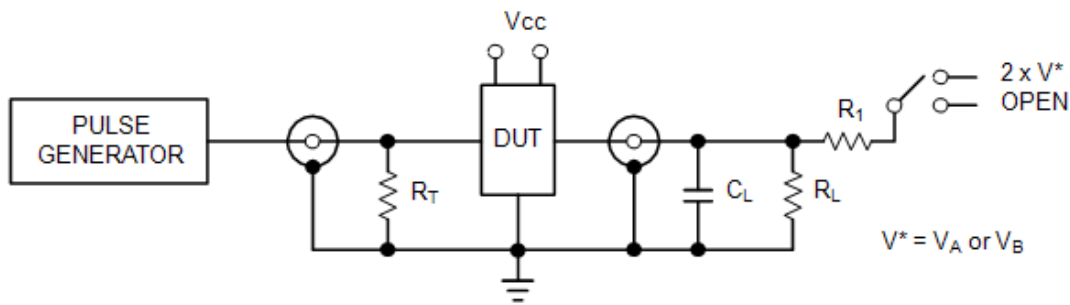

Figure 6. Definition of Timing Specification Parameters



Test	Switch
t_{PZH} , t_{PHZ}	Open
t_{PZL} , t_{PLZ}	$2 \times V^*$

$C_L = 15 \text{ pF}$ or equivalent (Includes jig and probe capacitance)
 $R_L = R_1 = 50 \text{ k}\Omega$ or equivalent
 $R_T = Z_{OUT}$ of pulse generator (typically 50Ω)
 $V^* = V_A$ or V_B for A or B measurements, respectively.

Figure 7. Test Circuit for Enable/Disable Time Measurement

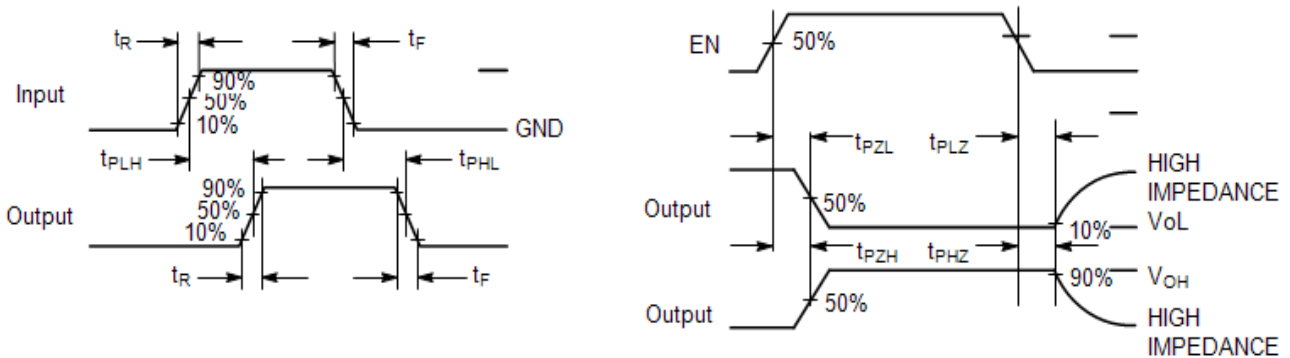

Figure 8. Timing Definitions for Propagation Delays and Enable/Disable Measurement

Functional Description

The PI4ULS5V202 is a 2-bit configurable dual supply bidirectional auto sensing translator that does not require a directional control pin. The A and B ports are designed to track two different power supply rails, V_{CCA} and V_{CCB} respectively. Both the V_{CCA} and V_{CCB} supply rails are configurable from 1.2 V to 5.5 V. This allows voltage logic signals on the V_{CCA} side to be translated into lower, higher or equal value voltage logic signals on the V_{CCB} side, and vice-versa.

The translator has integrated 10 k Ω pull-up resistors on the I/O lines. The integrated pull-up resistors are used to pull-up the I/O lines to either V_{CCA} or V_{CCB} . The PI4ULS5V202 is an excellent match for open-drain applications such as the I²C communication bus.

Application Information

Level Translator Architecture

The PI4ULS5V202 auto sense translator provides bidirectional voltage level shifting to transfer data in multiple supply voltage systems. This device has two supply voltages, V_{CCA} and V_{CCB} , which set the logic levels on the input and output sides of the translator. When used to transfer data from A port to B port, input signals referenced to the V_{CCA} supply are translated to output signals with a logic level matched to V_{CCB} . In a similar manner, translation shifts input signals with a logic level compatible to V_{CCB} to an output signal matched to V_{CCA} . The PI4ULS5V202 consists of two bidirectional channels that independently determine the direction of the data flow without requiring a directional pin. The one-shot circuits are used to detect the rising or falling input signals. In addition, the one shots decrease the rise and fall time of the output signal for high-to-low and low-to-high transitions. Each input/output channel has an internal 10 k Ω pull. The magnitude of the pull-up resistors can be reduced by connecting external resistors in parallel to the internal 10 k Ω resistors.

Input Driver Requirements

The rise (t_R) and fall (t_F) timing parameters of the open drain outputs depend on the magnitude of the pull-up resistors. In addition, the propagation times (t_{PD}), skew (t_{PSKEW}) and maximum data rate depend on the impedance of the device that is connected to the translator. The timing parameters listed in the data sheet assume that the output impedance of the drivers connected to the translator is less than 50 k Ω .

Enable Input (EN)

The PI4ULS5V202 has an Enable pin (EN) that provides tri-state operation at the I/O pins. Driving the Enable pin to a low logic level minimizes the power consumption of the device and drives the I/O V_{CCB} and I/O V_{CCA} pins to a high impedance state. Normal translation operation occurs when the EN pin is equal to a logic high signal. The EN pin is referenced to the V_{CCA} supply and has overvoltage tolerant protection.

Power Supply Guidelines

During normal operation, supply voltage V_{CCA} can be greater than, less than or equal to V_{CCB} . The sequencing of the power supplies will not damage the device during the power up operation. For optimal performance, 0.01 μ F to 0.1 μ F decoupling capacitors should be used on the V_{CCA} and V_{CCB} power supply pins. Ceramic capacitors are a good design choice to filter and bypass any noise signals on the voltage lines to the ground plane of the PCB. The noise immunity will be maximized by placing the capacitors as close as possible to the supply and ground pins, along with minimizing the PCB connection traces.

Part Marking

U Package



Y: Date Code (Year)
W: Date Code (Workweek)
1st X: Assembly Site Code
2nd X: Fab Site Code
Bar above "U" means Fab3 of MGN
Bar above fab site code means Cu wire

XV Package

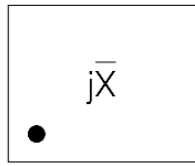

j: PI4ULS5V202XVE
X: Date Code (Year & Workweek)
Bar above "X" means Fab3 of MGN

Packaging Mechanical
UDFN-8 (XV)

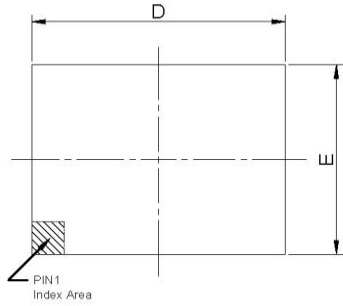

TOP VIEW

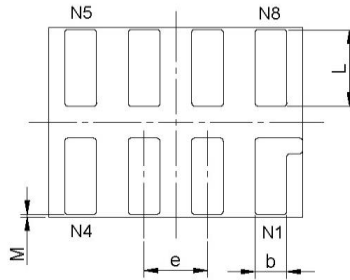

BOTTOM VIEW

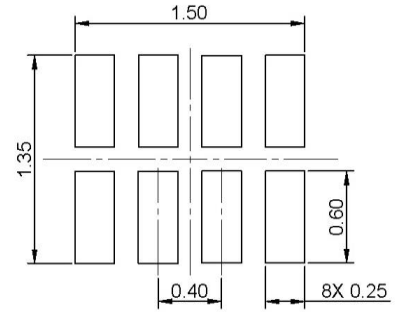

RECOMMENDED LAND PATTERN(unit:mm)

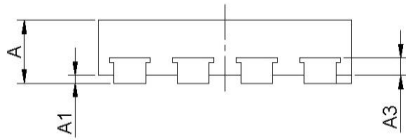

SIDE VIEW

PKG. DIMENSIONS(MM)		
SYMBOL	Min	Max
A	0.45	0.55
A1	0.00	0.05
A3	0.11 REF	
D	1.55	1.65
E	1.15	1.25
b	0.15	0.25
e	0.40 TYP	
L	0.45	0.55
M	0.00	0.03

Note:
1. Ref. JEDEC MO-287A



DATE: 05/14/14

DESCRIPTION: 8-Pin, UDFN, 1.2X1.6, MIS

PACKAGE CODE: XV (XV8)

DOCUMENT CONTROL #: PD-2131

REVISION: A

14-0141

Recommended Land Pattern for DFN1.6*1.2

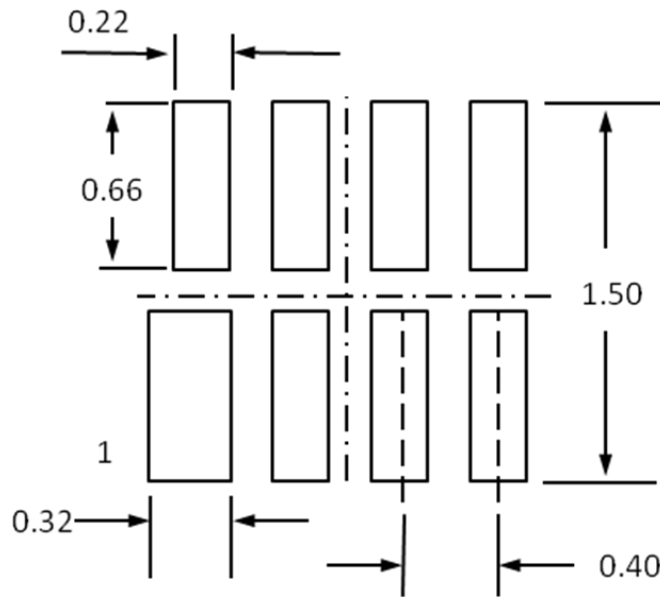

Note:
All linear dimensions are in millimeters

MSOP-8 (U)

PKG DIMENSIONS(MM)		
SYMBOL	Min.	Max.
A	--	1.10
A1	0.00	0.15
A2	0.75	0.95
b	0.22	0.38
c	0.08	0.23
D	2.80	3.20
E	4.65	5.15
E1	2.80	3.20
e	0.65 BSC	
L	0.40	0.80
L1	0.95 REF	
θ	0°	8°

NOTE:
 1. ALL DIMENSIONS ARE IN MILLIMETERS. ANGLES IN DEGREES.
 2. REFER JEDEC MO-187F/AA
 3. PACKAGE OUTLINE DIMENSIONS DO NOT INCLUDE MOLD FLASH AND METAL BURR.

DIODES INCORPORATED	PERICOM ENABLING SERIAL CONNECTIVITY	DATE: 11/03/16
DESCRIPTION: 8-Pin, Mini Small Outline Package, MSOP		
PACKAGE CODE: U (U8)		
DOCUMENT CONTROL #: PD-1261	REVISION: G	

16-0242

For latest package info.

please check: <http://www.diodes.com/design/support/packaging/pericom-packaging/packaging-mechanicals-and-thermal-characteristics/>

Ordering Information

Part Number	Package Code	Package Description
PI4ULS5V202XVEX	XV	8-pin, 1.2x1.6, MIS (UDFN)
PI4ULS5V202UEX	U	8-pin, Mini Small Outline Package (MSOP)

- Notes:**
- No purposely added lead. Fully EU Directive 2002/95/EC (RoHS), 2011/65/EU (RoHS 2) & 2015/863/EU (RoHS 3) compliant.
 - See <https://www.diodes.com/quality/lead-free/> for more information about Diodes Incorporated's definitions of Halogen- and Antimony-free, "Green" and Lead-free.
 - Halogen- and Antimony-free "Green" products are defined as those which contain <900ppm bromine, <900ppm chlorine (<1500ppm total Br + Cl) and <1000ppm antimony compounds.
 - E = Pb-free and Green
 - X suffix = Tape/Reel

IMPORTANT NOTICE

DIODES INCORPORATED MAKES NO WARRANTY OF ANY KIND, EXPRESS OR IMPLIED, WITH REGARDS TO THIS DOCUMENT, INCLUDING, BUT NOT LIMITED TO, THE IMPLIED WARRANTIES OF MERCHANTABILITY AND FITNESS FOR A PARTICULAR PURPOSE (AND THEIR EQUIVALENTS UNDER THE LAWS OF ANY JURISDICTION).

Diodes Incorporated and its subsidiaries reserve the right to make modifications, enhancements, improvements, corrections or other changes without further notice to this document and any product described herein. Diodes Incorporated does not assume any liability arising out of the application or use of this document or any product described herein; neither does Diodes Incorporated convey any license under its patent or trademark rights, nor the rights of others. Any Customer or user of this document or products described herein in such applications shall assume all risks of such use and will agree to hold Diodes Incorporated and all the companies whose products are represented on Diodes Incorporated website, harmless against all damages.

Diodes Incorporated does not warrant or accept any liability whatsoever in respect of any products purchased through unauthorized sales channel.

Should Customers purchase or use Diodes Incorporated products for any unintended or unauthorized application, Customers shall indemnify and hold Diodes Incorporated and its representatives harmless against all claims, damages, expenses, and attorney fees arising out of, directly or indirectly, any claim of personal injury or death associated with such unintended or unauthorized application.

Products described herein may be covered by one or more United States, international or foreign patents pending. Product names and markings noted herein may also be covered by one or more United States, international or foreign trademarks.

This document is written in English but may be translated into multiple languages for reference. Only the English version of this document is the final and determinative format released by Diodes Incorporated.

LIFE SUPPORT

Diodes Incorporated products are specifically not authorized for use as critical components in life support devices or systems without the express written approval of the Chief Executive Officer of Diodes Incorporated. As used herein:

A. Life support devices or systems are devices or systems which:

1. are intended to implant into the body, or
2. support or sustain life and whose failure to perform when properly used in accordance with instructions for use provided in the labeling can be reasonably expected to result in significant injury to the user.

B. A critical component is any component in a life support device or system whose failure to perform can be reasonably expected to cause the failure of the life support device or to affect its safety or effectiveness.

Customers represent that they have all necessary expertise in the safety and regulatory ramifications of their life support devices or systems, and acknowledge and agree that they are solely responsible for all legal, regulatory and safety-related requirements concerning their products and any use of Diodes Incorporated products in such safety-critical, life support devices or systems, notwithstanding any devices- or systems-related information or support that may be provided by Diodes Incorporated. Further, Customers must fully indemnify Diodes Incorporated and its representatives against any damages arising out of the use of Diodes Incorporated products in such safety-critical, life support devices or systems.

Copyright © 2020, Diodes Incorporated
www.diodes.com