

SPECIFICATION FOR APPROVAL

Customer:

Description:	EC FAN		
Customer P/N:		REV:	
Delta Model NO.:	GTB036PUD25R	Safety Model NO.:	GTB036PUD25
Sample Rev:	X02	Issue NO:	
Sample Issue Date:		Quantity:	

1. SCOPE:

THIS SPECIFICATION DEFINES THE ELECTRICAL AND MECHANICAL CHARACTERISTICS OF THIS CENTRIFUGAL FAN.

2. NOMINAL DATA:

UNLESS SPECIFIED, ALL READINGS AND TESTS ARE BASED ON 25 DEG C, 65% RH.

ITEM	DESCRIPTION
NOMINAL VOLTAGE	3 ϕ 400 VAC 50/60Hz
NOMINAL VOLTAGE RANGE	3 ϕ 380 - 480 VAC
INPUT POWER @ FREE-AIR	648 W
INPUT POWER @ MAX. LOAD	1000 W
INPUT CURRENT (MAX.)	1.75 A
SPEED	2200 R.P.M. (REF.)
MAX. AIR FLOW (AT ZERO STATIC PRESSURE)	5189 (MIN.4670) M ³ /H 3054 (MIN.2749) CFM
MAX. AIR PRESSURE (AT ZERO AIR FLOW)	829.5 (MIN.671.9) Pa 3.330 (MIN.2.697) inchH ₂ O
ACOUSTICAL NOISE (AVG.) @ FREE-AIR	80.0 (MAX 85.0) dB(A)

- NOTES: 1. ALL READINGS ARE MEASURED AFTER STABLY WARMING UP THROUGH 10 MINUTES.
 2. THE VALUES WRITTEN IN PARENS , (), ARE LIMITED SPEC.
 3. ACOUSTICAL NOISE MEASURING CONDITION:

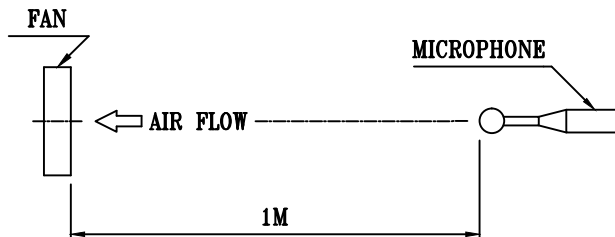

NOISE IS MEASURED AT NOMINAL VOLTAGE IN FREE AIR IN ANECHOIC CHAMBER WITH B & K SOUND LEVEL METER WITH MICROPHONE AT A DISTANCE OF ONE METER FROM THE FAN INTAKE.

PART NO:

DELTA MODEL: GTB036PUD25R

3. FEATURES:

DIRECTION OF ROTATION	CLOCKWISE, SEEN ON ROTOR
BEARING SYSTEM	BALL BEARINGS
WEIGHT	10.1 K.G. (REF.)
MATERIAL OF ELECTRONICS HOUSING	DIE-CAST ALUMINUM
MATERIAL OF IMPELLER	ALUMINUM SHEET
ELECTRICAL LEADS	VIA TERMINAL BLOCK
MOTOR PROTECTION	OVER TEMPERATURE PROTECTED
LEAKAGE CURRENT	$\leq 3.5 \text{ mA}$
INSULATION CLASS	B
TYPE OF PROTECTION	IP54
PROTECTION CLASS	I
POWER FACTOR CORRECTION	PASSIVE
OPERATING TEMPERATURE	$-25 \sim +60 \text{ }^\circ\text{C}$ (REF.)
STORAGE TEMPERATURE	$-40 \sim +70 \text{ }^\circ\text{C}$ (REF.)
EMC	EN61000-6-2/3 , EN61000-3-2/3
SAFETY	UL , cUL & TUV
LIFE EXPECTANCE	* 60,000 HOURS CONTINOUS OPERATION AT $40 \text{ }^\circ\text{C}$ WITH $15 \sim 65 \text{ \%RH}$.
FUNCTIONS	- CONTROL INPUT 0-10VDC or PWM PATTERN or 4-20mA - OUTPUT +10VDC($\pm 10\%$), max. 10mA - CONTROL VOLTAGE OUTPUT, 0-10VDC - RS485 CONTROL BUS - ALARM RELAY, LOCKED ROTOR PROTECTION, SOFT START - SPEED TELLING, FREQUENCY GENERATOR SIGNAL - VOLTAGE/CURRENT MONITORING

PART NO:

DELTA MODEL: GTB036PUD25R

4. P & Q CURVE:

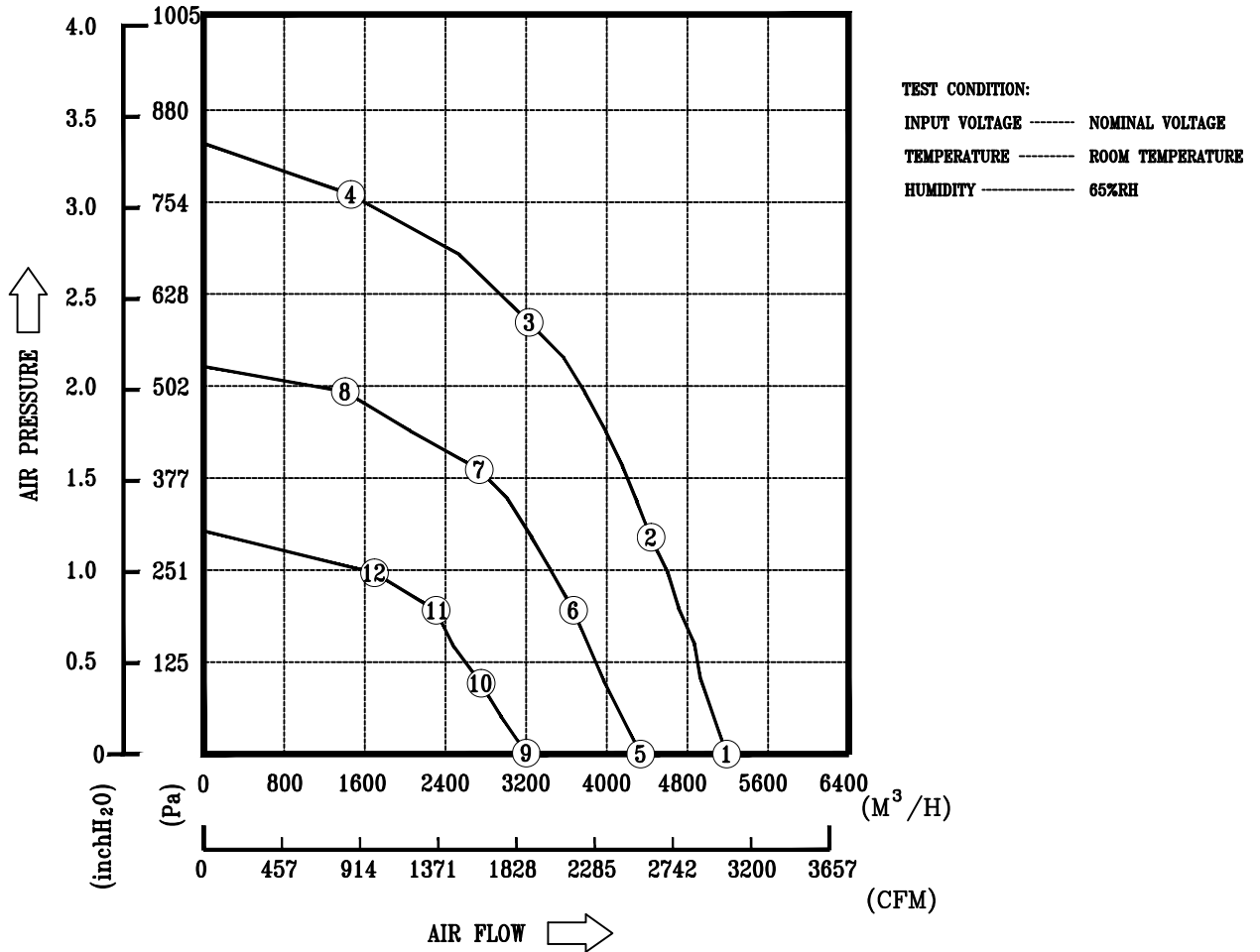

MEASURED DATA:

	P	Q	N	P1	I	Lp
	[Pa]	[M ³ /H]	[R.P.M.]	[W]	[A]	[dB(A)]
1	0	5189	2200	648	1.16	80.0
2	294.3	4438	2200	964	1.69	
3	586.6	3230	2200	970	1.70	
4	760.3	1459	2200	744	1.31	
5	0	4336	1756	397	0.81	75.0
6	195.2	3669	1762	500	0.96	
7	386.5	2733	1748	535	1.00	
8	492.5	1403	1760	436	0.86	
9	0	3206	1316	172	0.39	73.0
10	96.1	2752	1311	203	0.45	
11	195.2	2306	1331	235	0.50	
12	246.2	1693	1337	229	0.49	

PART NO:

DELTA MODEL: GTB036PUD25R

5. DIMENSION DRAWING:

LABEL 1

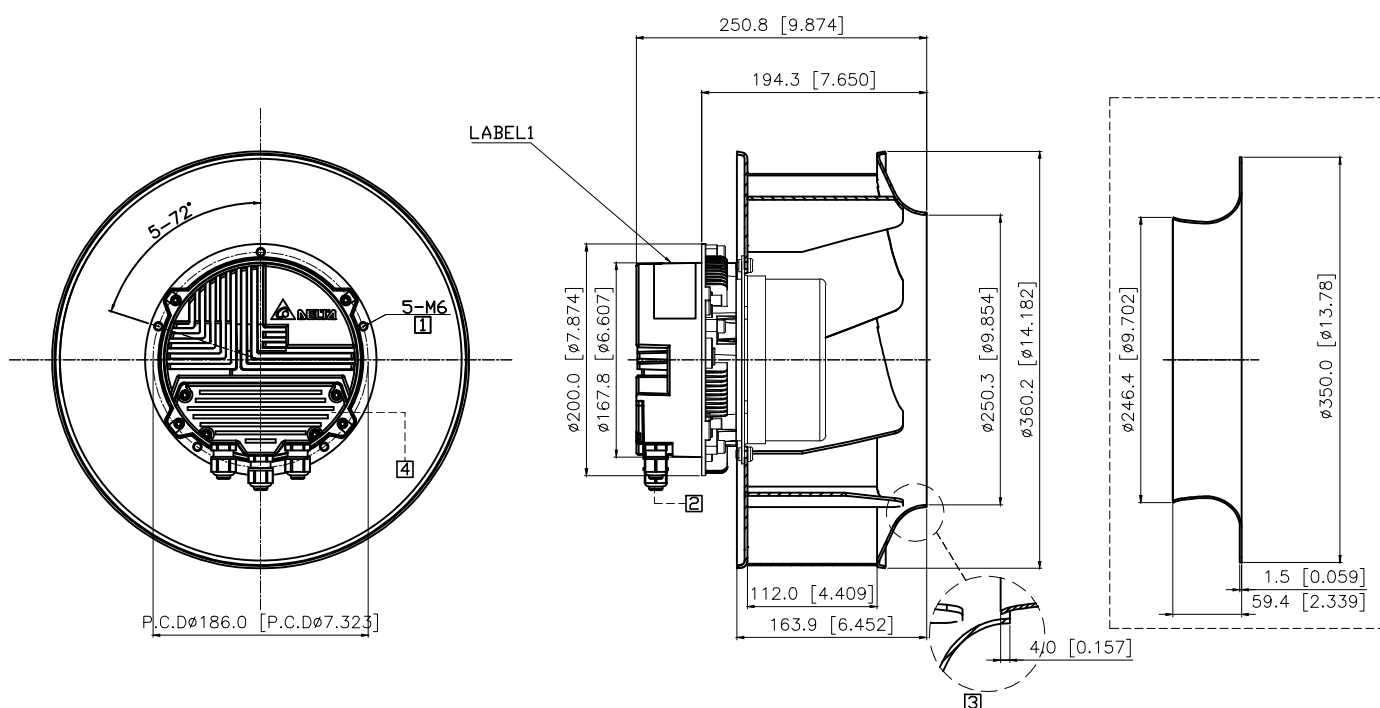

NOTE:

- 1 DEPTH OF SCREW: 12~16mm.
- 2 CABLE DIAMETER: ϕ 6.0~ ϕ 10.0mm.
- 3 ACCESSORY: INLET NOZZLE, ALL THE PERFORMANCE DATA ARE MEASURED WITH IT.
- 4 OPEN THE COVER AND REFER TO DEFINITION OF TERMINAL BLOCK.
- 5 THIS PRODUCT IS RoHS COMPLIANT.

PART NO:

DELTA MODEL: GTB036PUD25R

6. DEFINITION OF TERMINAL BLOCK:

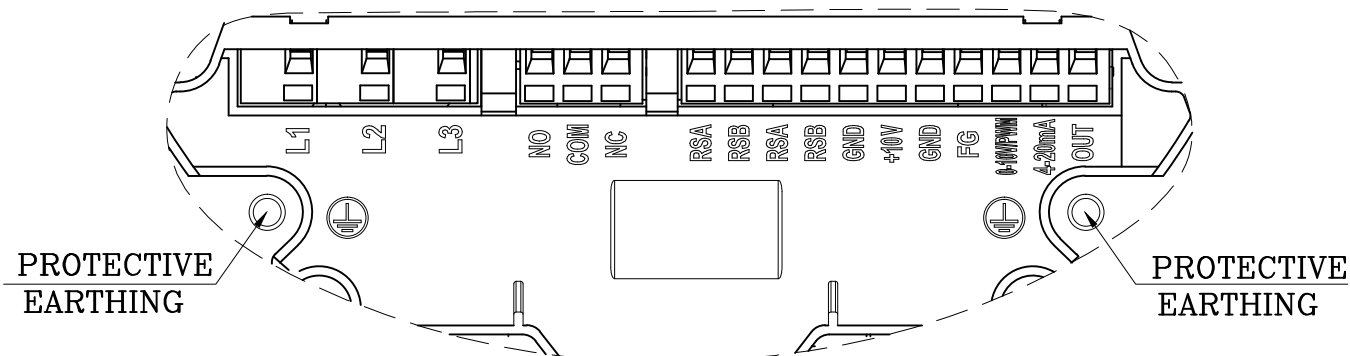

TEXT	FUNCTIONS
L1	AC MAINS
L2	AC MAINS
L3	AC MAINS
NO	ALARM RELAY, OPEN BY FAILURE
COM	ALARM RELAY, COMMON(2A/250VAC)
NC	ALARM RELAY, CLOSE BY FAILURE
RSA	RS485-A
RSB	RS485-B
RSA	RS485-A
RSB	RS485-B
GND	GROUND
+10V	+10V OUTPUT, MAX 10mA (FOR EXTERNAL POTENTIOMETER)
GND	GROUND
FG	FREQUENCY GENERATOR (FG) SIGNAL
0-10V/PWM	SPEED CONTROL, INPUT 0-10VDC
4-20mA	SPEED CONTROL, INPUT 4-20mA
OUT	CONTROL VOLTAGE OUTPUT 0-10VDC (FOR EXTERNAL POTENTIOMETER)

PART NO:

DELTA MODEL: GTB036PUD25R

7. LEAD WIRE CONNECTION:

SPEED CONTROL APPLICATION
(CHOOSE ONE TO USE)

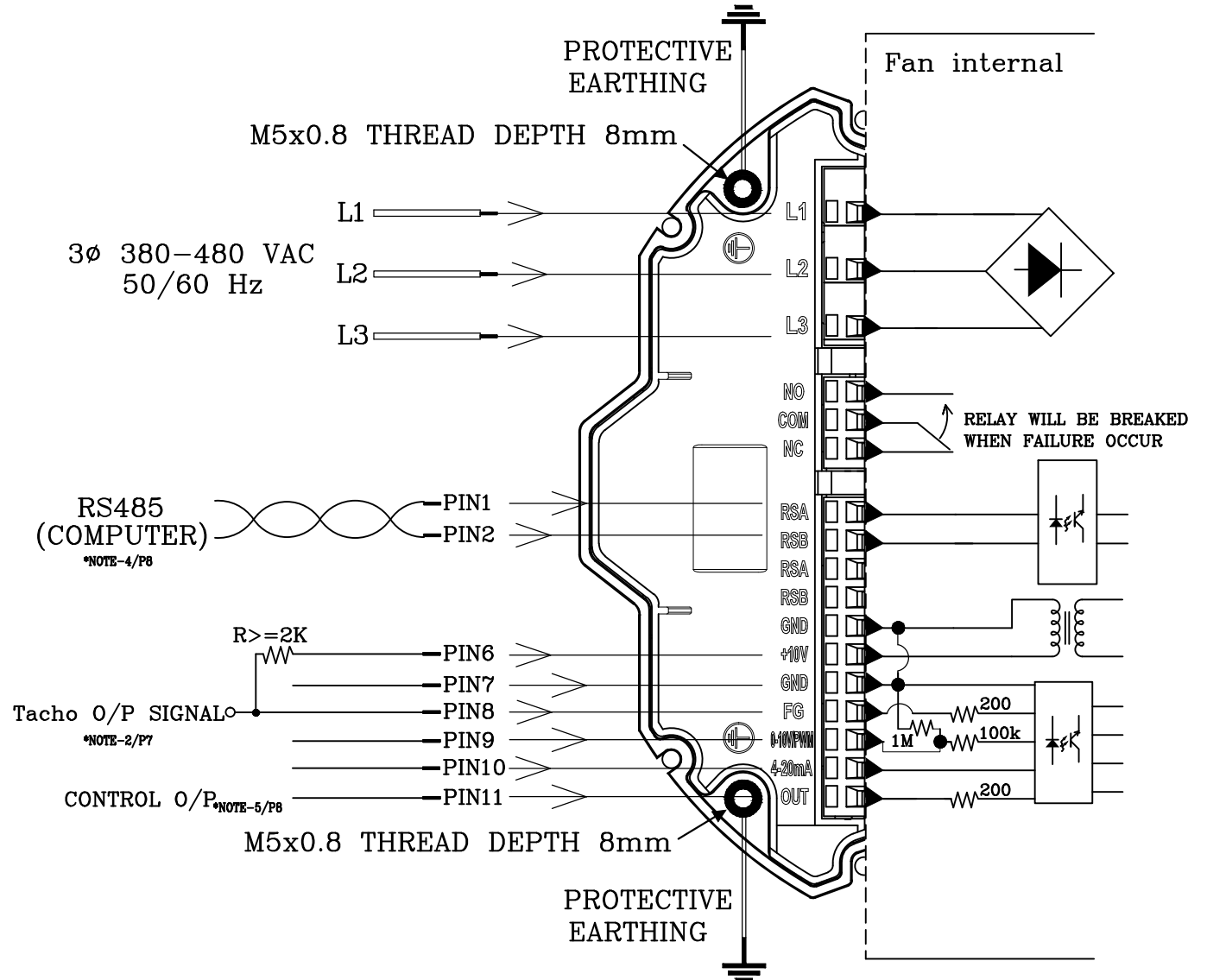
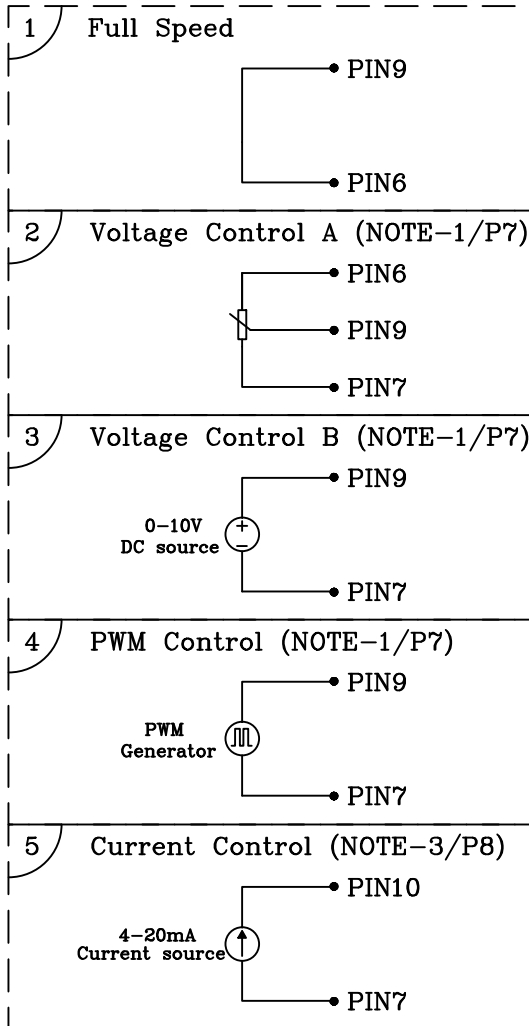

PART NO:

DELTA MODEL: GTB036PUD25R

8. SPEED CONTROL SIGNAL: VOLTAGE CONTROL *NOTE-1

- THERE ARE TWO WAYS TO CONTROL SPEED AND MUST OPEN 4-20mA INPUT.

A. VOLTAGE CONTROL

- CONTROL VOLTAGE RANGE SHALL BE 0-10 VDC.
- VOLTAGE AT 10 VDC THE FAN WILL SPIN AT MAXIMUM SPEED.
- VOLTAGE HIGHER THAN 1.5 VDC, THE FAN WILL START UP.
- VOLTAGE LOWER THAN 0.5 VDC, THE FAN WILL STOP.

B. PWM CONTROL

- THE AMPLITUDE VOLTAGE SHALL BE 10VDC. (100Hz~100kHz)

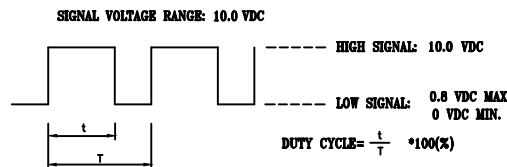

- PWM DUTY HIGHER THAN 15 % , THE FAN WILL START UP.
- PWM DUTY LOWER THAN 5 % , THE FAN WILL STOP.

- THE SPEED COMPARISON WITH CONTROL LEVEL:

VOLTAGE(V)	PWM DUTY(%)	SPEED (R.P.M.) (REF.)
0.0	0	0
1.5	15	390
6.0	60	1465
9.5	95	2200

*NOTE-2: FREQUENCY GENERATOR (FG) SIGNAL

$V_{CE}(\text{sat}) = 0.7V \text{ MAX.}$

$V_{FG} = 30.0V \text{ MAX.}$

$I_c = 5mA \text{ MAX.}$

$R \geq V_{FG} / I_c$

FREQUENCY GENERATOR WAVEFORM

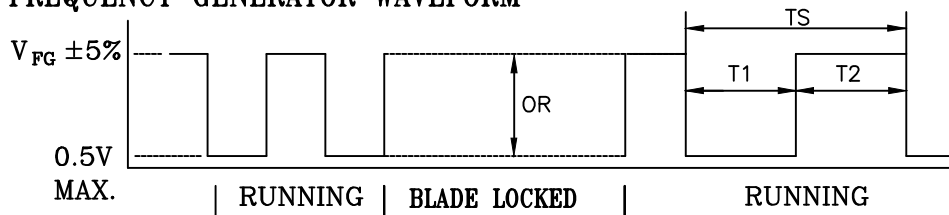

$N = \text{R.P.M}$	1 PULSE PER REVOLUTION
$TS = 60/N(\text{SEC})$	$T_1 = T_2 = 1/2 TS$

PART NO:

DELTA MODEL: GTB036PUD25R

9. SPEED CONTROL SIGNAL: CURRENT CONTROL *NOTE-3

- SPEED CAN BE CONTROLLED BY CURRENT LEVEL AND MUST OPEN 0-10V/PWM INPUT.
 - CONTROL VOLTAGE RANGE SHALL BE 4.0-20 mA.
 - CURRENT HIGHER THAN 19.5 mA, THE FAN WILL SPIN AT MAXIMUM SPEED.
 - CURRENT HIGHER THAN 6.0 mA, THE FAN WILL START UP.
 - CURRENT LOWER THAN 4.5 mA, THE FAN WILL STOP.

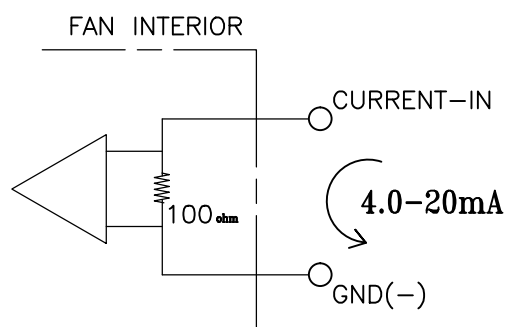

- THE SPEED COMPARISON WITH CONTROL LEVEL:

CURRENT(mA)	SPEED (R.P.M.) <small>(REF.)</small>
4.0	0
6.3	390
14.0	1515
19.5	2200

10. FUNCTION CONTROL: RS485 CONTROL

*NOTE-4: RS485 CONTROL FUNCTION

- SELECT THE CONTROL MODE OF SPEED, FIXED SPEED OR FIXED PWM DUTY.
- SPEED AND POWER CONSUMPTION FEEDBACK.
- ALLOW MULTIPLE FANS CONTROL AND STATUS PATROL.

11. CONTROL O/P *NOTE-5

- THIS ANALOG SIGNAL LEVEL IS THE DERIVATIVE OF CURRENT CONTROL LEVEL.
- THE SIGNAL WILL BE 0-10 VDC.

CURRENT(mA)	CONTROL O/P(VDC) <small>(REF.)</small>
4.0	0
6.3	1.55
14.0	6.17
19.5	9.46

PART NO:

DELTA MODEL: GTB036PUD25R

12. CONTROL VOLTAGE(PWM DUTY) & SPEED CURVE:
(SPEED CONTROL PIN)

