

Low noise JFET dual operational amplifiers

Datasheet - production data

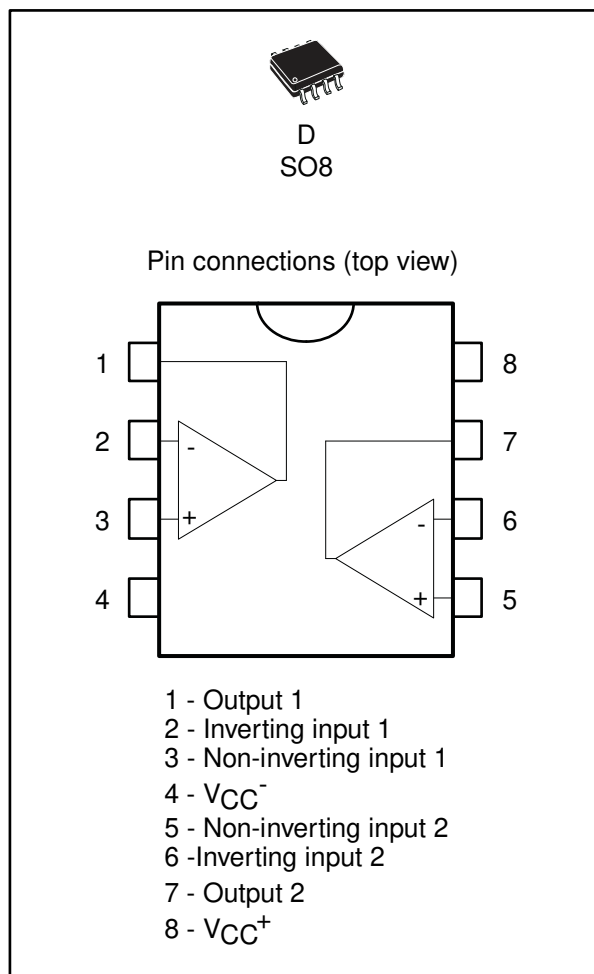

Features

- Wide common-mode (up to V_{CC}^+) and differential voltage range
- Low input bias and offset current
- Low noise $e_n = 15 \text{ nV}/\sqrt{\text{Hz}}$ (typ)
- Output short-circuit protection
- High input impedance JFET input stage
- Low harmonic distortion: 0.01 % (typical)
- Internal frequency compensation
- Latch-up free operation
- High slew rate: $16 \text{ V}/\mu\text{s}$ (typ)

Related products

- See TL071 for single op amp version
- See TL074 for quad op amp version

Description

The TL072, TL072A, and TL072B are high speed JFET input dual operational amplifiers incorporating well-matched, high-voltage JFET and bipolar transistors in a monolithic integrated circuit.

The devices feature high slew rates, low input bias and offset current, and low offset voltage temperature coefficients.

Contents

1	Schematic diagram.....	3
2	Absolute maximum ratings and operating conditions	4
3	Electrical characteristics	5
4	Parameter measurement information	10
5	Typical application	11
6	Package information	12
	6.1 SO8 package information.....	12
7	Ordering information.....	14
8	Revision history	15

1 Schematic diagram

Figure 1: Schematic diagram

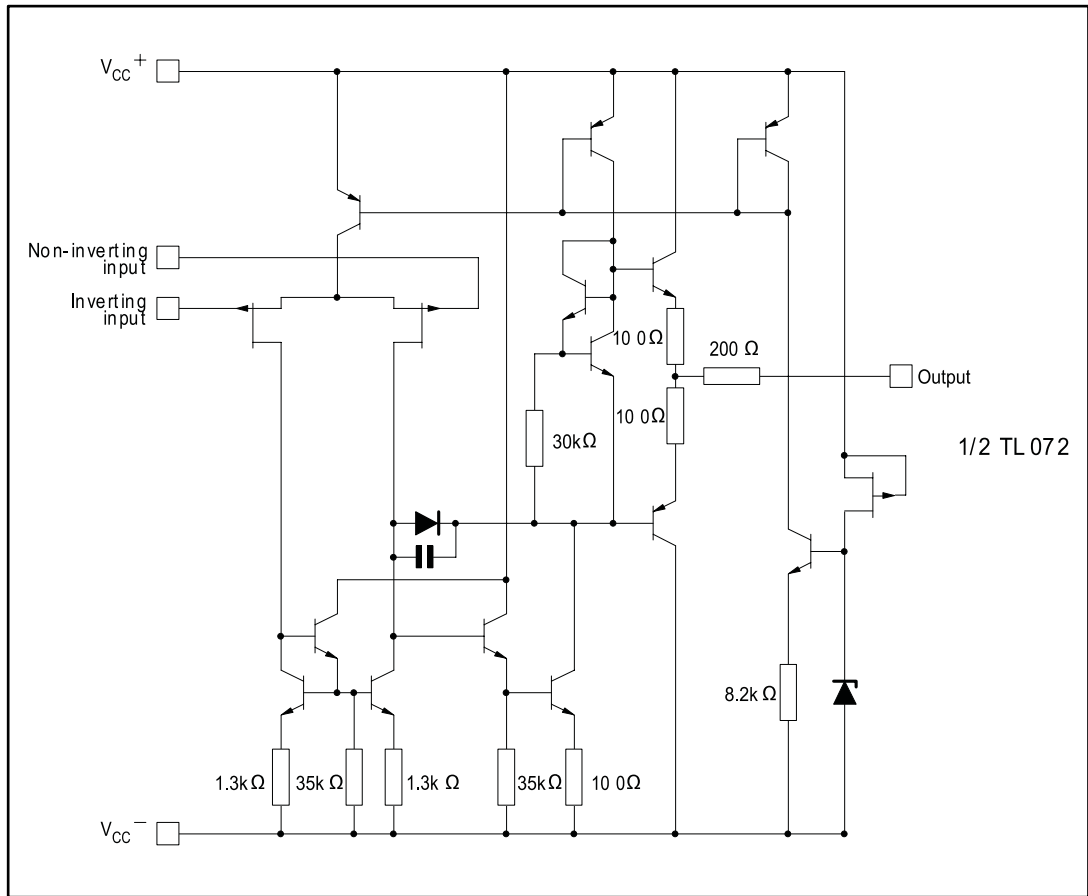

2 Absolute maximum ratings and operating conditions

Table 1: Absolute maximum ratings

Symbol	Parameter	TL072I, AI, BI	TL072C, AC, BC	Unit
V_{CC}	Supply voltage ⁽¹⁾	±18		V
V_{in}	Input voltage ⁽²⁾	±15		
V_{id}	Differential input voltage ⁽³⁾	±30		
R_{thja}	Thermal resistance junction to ambient, SO8 ⁽⁴⁾	125		°C/W
R_{thjc}	Thermal resistance junction to case, SO8 ⁽⁴⁾	40		
	Output short-circuit duration ⁽⁵⁾	Infinite		
T_{stg}	Storage temperature range	-65 to +150		°C
ESD	HBM: human body model ⁽⁶⁾	1		kV
	MM: machine model ⁽⁷⁾	200		V
	CDM: charged device model ⁽⁸⁾	1.5		kV

Notes:

⁽¹⁾All voltage values, except the differential voltage, are with respect to the zero reference level (ground) of the supply voltages where the zero reference level is the midpoint between V_{CC}^+ and V_{CC}^- .

⁽²⁾The magnitude of the input voltage must never exceed the magnitude of the supply voltage or 15 volts, whichever is less.

⁽³⁾Differential voltages are the non-inverting input terminal voltages with respect to the inverting input terminal.

⁽⁴⁾Short-circuits can cause excessive heating. Destructive dissipation can result from simultaneous short-circuits on all amplifiers.

⁽⁵⁾The output may be shorted to ground or to either supply. Temperature and/or supply voltages must be limited to ensure that the dissipation rating is not exceeded.

⁽⁶⁾Human body model: 100 pF discharged through a 1.5 kΩ resistor between two pins of the device. This is done for all couples of pin combinations with other pins floating.

⁽⁷⁾Machine model: a 200 pF cap is charged to the specified voltage, then discharged directly between two pins of the device with no external series resistor (internal resistor < 5 W). This is done for all couples of pin combinations with other pins floating.

⁽⁸⁾Charged device model: all pins plus package are charged together to the specified voltage and then discharged directly to the ground.

Table 2: Operating conditions

Symbol	Parameter	TL072I, AI, BI	TL072C, AC, BC	Unit
V_{CC}	Supply voltage	6 to 36		V
T_{oper}	Operating free-air temperature range	-40 to +125	0 to +70	°C

3 Electrical characteristics

Table 3: Electrical characteristics at VCC = ±15 V, Tamb = +25 °C (unless otherwise specified).

Symbol	Parameter	TL072I, AC, AI, BC, BI			TL072C			Unit	
		Min.	Typ.	Max.	Min.	Typ.	Max.		
V _{io}	Input offset voltage (R _s = 50 Ω) T _{amb} = +25 °C	TL072		3	10		3	10	mV
		TL072A		3	6				
		TL072B		1	3				
	Input offset voltage (R _s = 50 Ω) T _{min} ≤ T _{amb} ≤ T _{max}	TL072			13			13	
		TL072A			7				
		TL072B			5				
ΔV _{io} /ΔT	Input offset voltage drift		10			10		μV/°C	
I _{io}	Input offset current, T _{amb} = +25 °C ⁽¹⁾		5	100		5	100	pA	
	Input offset current, T _{min} ≤ T _{amb} ≤ T _{max}			4			10	nA	
I _{ib}	Input bias current, T _{amb} = +25 °C ⁽¹⁾		20	200		20	200	pA	
	Input bias current, T _{min} ≤ T _{amb} ≤ T _{max} ⁽¹⁾			20			20	nA	
A _{vd}	Large signal voltage gain (R _L = 2 kΩ, V _o = ±10 V), T _{amb} = +25 °C	50	200		25	200		V/mV	
	Large signal voltage gain (R _L = 2 kΩ, V _o = ±10 V), T _{min} ≤ T _{amb} ≤ T _{max}	25			15				
SVR	Supply voltage rejection ratio (R _S = 50 Ω), T _{amb} = +25 °C	80	86		70	86		dB	
	Supply voltage rejection ratio (R _S = 50 Ω), T _{min} ≤ T _{amb} ≤ T _{max}	80			70				
I _{CC}	Supply current, no load, T _{amb} = +25 °C		1.4	2.5		1.4	2.5	mA	
	Supply current, no load, T _{min} ≤ T _{amb} ≤ T _{max}			2.5			2.5		
V _{icm}	Input common mode voltage range	±11	-12 to +15		±11	-12 to +15		V	
CMR	Common mode rejection ratio (R _S = 50 Ω), T _{amb} = +25 °C	80	86		70	86		dB	
	Common mode rejection ratio (R _S = 50 Ω), T _{min} ≤ T _{amb} ≤ T _{max}	80			70				
I _{os}	Output short-circuit current, T _{amb} = +25 °C	10	40	60	10	40	60	mA	
	Output short-circuit current, T _{min} ≤ T _{amb} ≤ T _{max}	10		60	10		60		
±V _{opp}	Output voltage swing, T _{amb} = +25 °C	R _L = 2 kΩ	10	12		10	12	V	
		R _L = 10 kΩ	12	13.5		12	13.5		
	Output voltage swing, T _{min} ≤ T _{amb} ≤ T _{max}	R _L = 2 kΩ	10			10			
		R _L = 10 kΩ	12			12			

Electrical characteristics

TL072, TL072A, TL072B

Symbol	Parameter	TL072I, AC, AI, BC, BI			TL072C			Unit
		Min.	Typ.	Max.	Min.	Typ.	Max.	
SR	Slew rate, $V_{in} = 10\text{ V}$, $R_L = 2\text{ k}\Omega$, $C_L = 100\text{ pF}$, unity gain	8	16		8	16		V/ μs
t_r	Rise time, $V_{in} = 20\text{ mV}$, $R_L = 2\text{ k}\Omega$, $C_L = 100\text{ pF}$, unity gain		0.1			0.1		μs
K_{ov}	Overshoot, $V_{in} = 20\text{ mV}$, $R_L = 2\text{ k}\Omega$, $C_L = 100\text{ pF}$, unity gain		10			10		%
GBP	Gain bandwidth product, $V_{in} = 10\text{ mV}$, $R_L = 2\text{ k}\Omega$, $C_L = 100\text{ pF}$, $F = 100\text{ kHz}$	2.5	4		2.5	4		MHz
R_i	Input resistance		10^{12}			10^{12}		Ω
THD	Total harmonic distortion, $F = 1\text{ kHz}$, $R_L = 2\text{ k}\Omega$, $C_L = 100\text{ pF}$, $A_v = 20\text{ dB}$, $V_o = 2\text{ V}_{pp}$		0.01			0.01		%
e_n	Equivalent input noise voltage, $R_S = 100\ \Omega$, $F = 1\text{ kHz}$		15			15		$\frac{\text{nV}}{\sqrt{\text{Hz}}}$
ϕ_m	Phase margin		45			45		degrees
V_{o1}/V_{o2}	Channel separation, $A_v = 100$		120			120		dB

Notes:

(1) The input bias currents are junction leakage currents which approximately double for every 10 °C increase in the junction temperature.

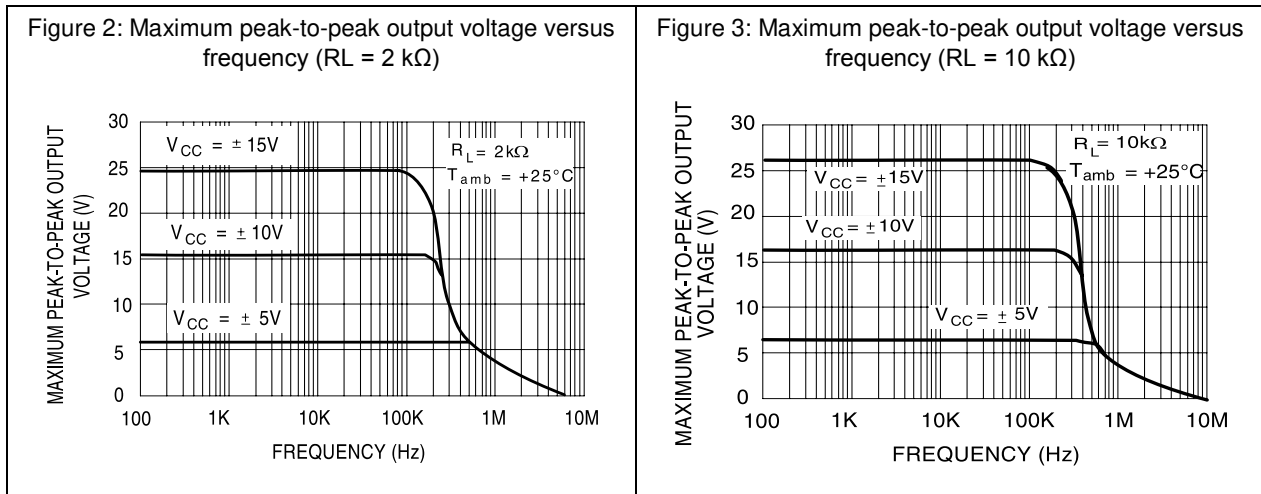

Figure 4: Maximum peak-to-peak output voltage versus frequency

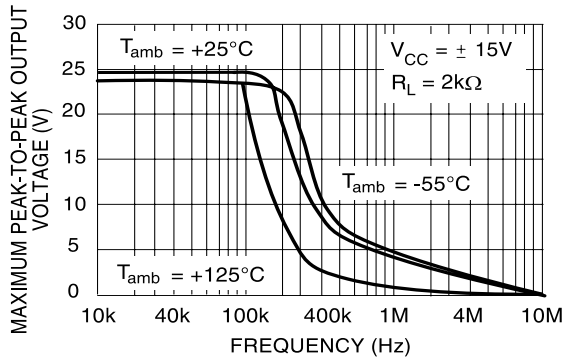

Figure 5: Maximum peak-to-peak output voltage versus free air temperature

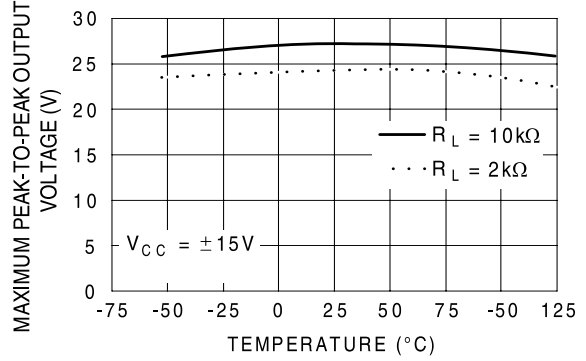

Figure 6: Maximum peak-to-peak output voltage versus load resistance

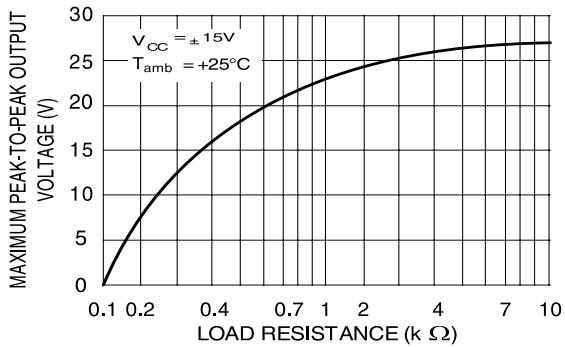

Figure 7: Maximum peak-to-peak output voltage versus supply voltage

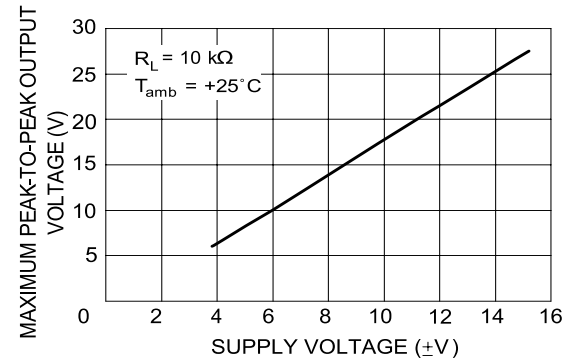

Figure 8: Input bias current versus free air temperature

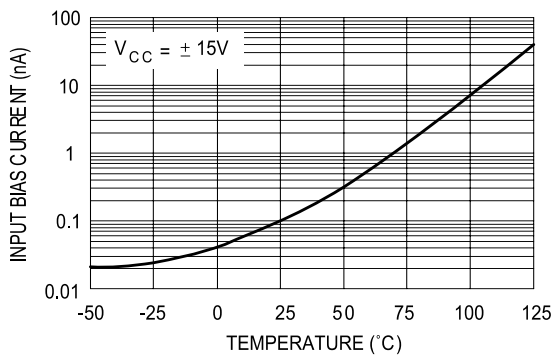

Figure 9: Large signal differential voltage amplification versus free air temperature

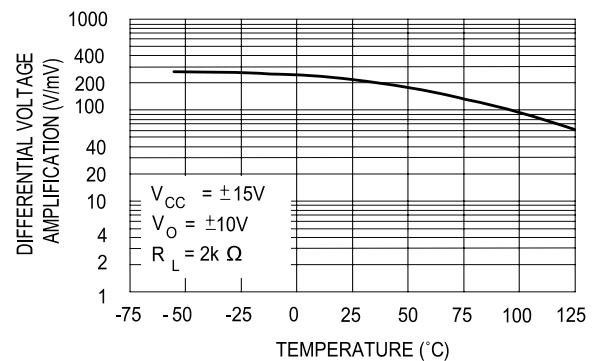

Figure 10: Large signal differential voltage amplification and phase shift versus frequency

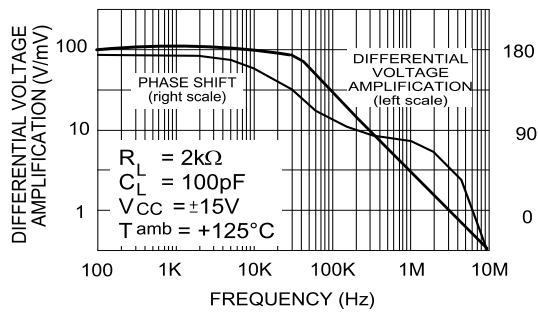

Figure 11: Total power dissipation versus free air temperature

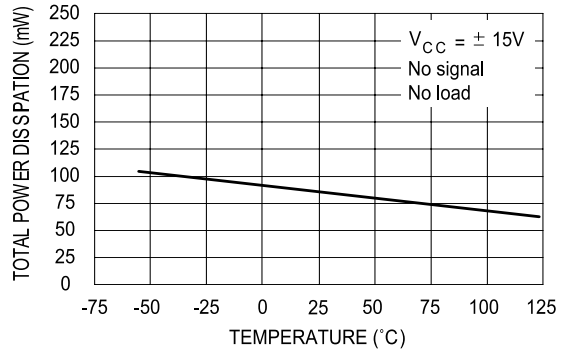

Figure 12: Supply current per amplifier versus free air temperature

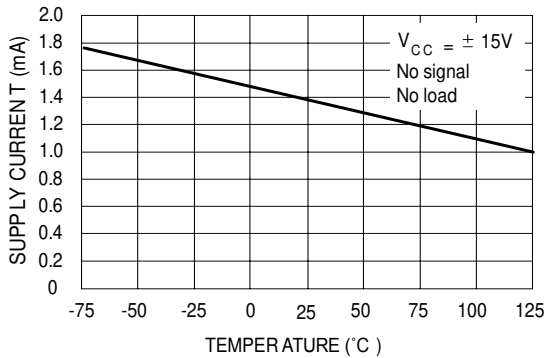

Figure 13: Common mode rejection ratio versus free air temperature

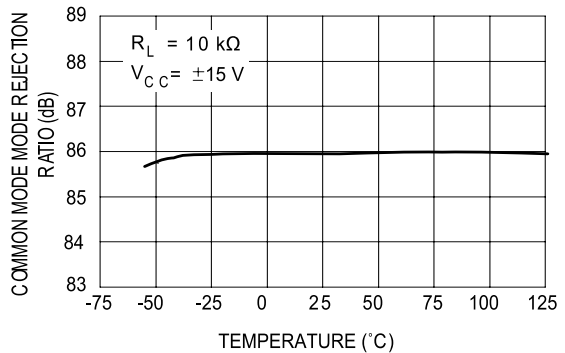

Figure 14: Voltage follower large signal pulse response

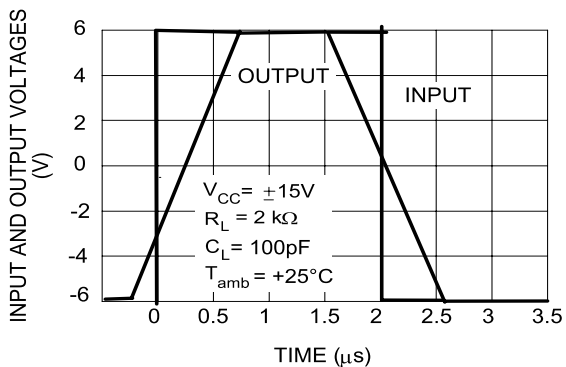

Figure 15: Output voltage versus elapsed time

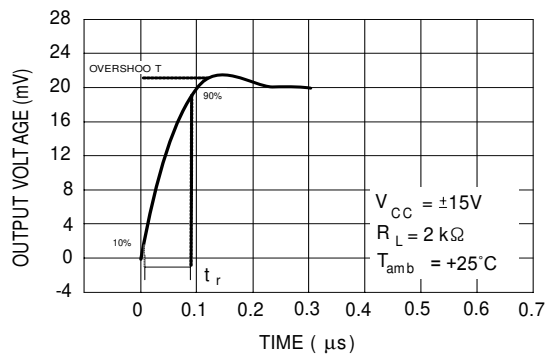

Figure 16: Equivalent input noise voltage versus frequency

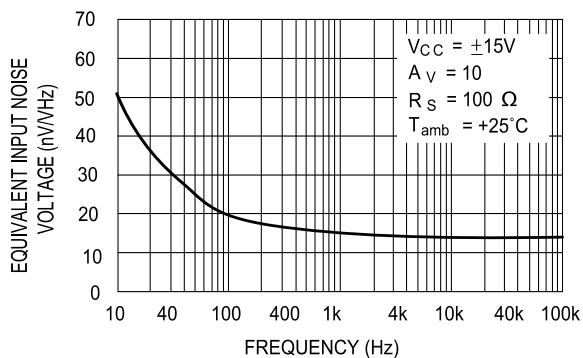
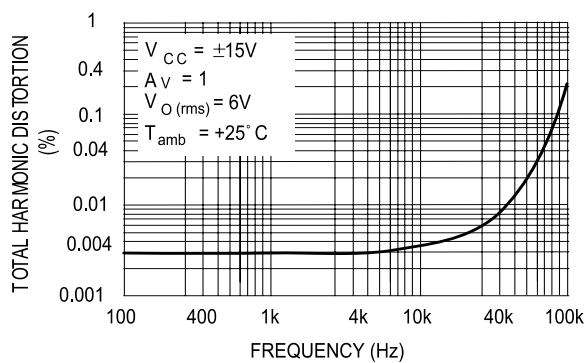

Figure 17: Total harmonic distortion versus frequency



4 Parameter measurement information

Figure 18: Voltage follower

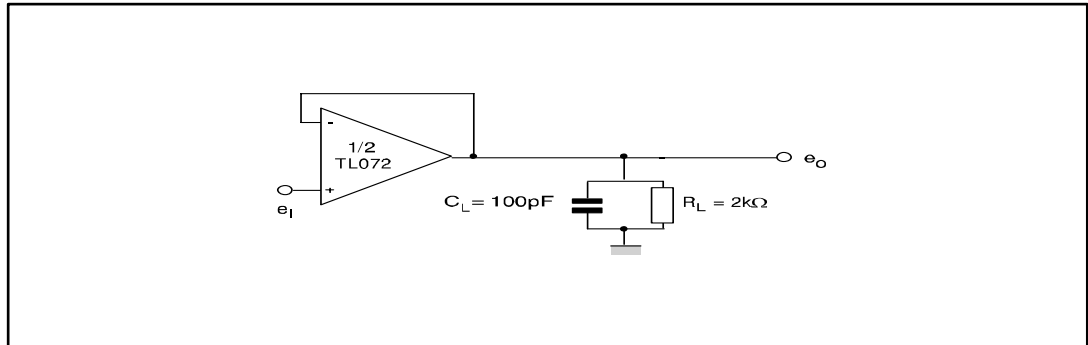
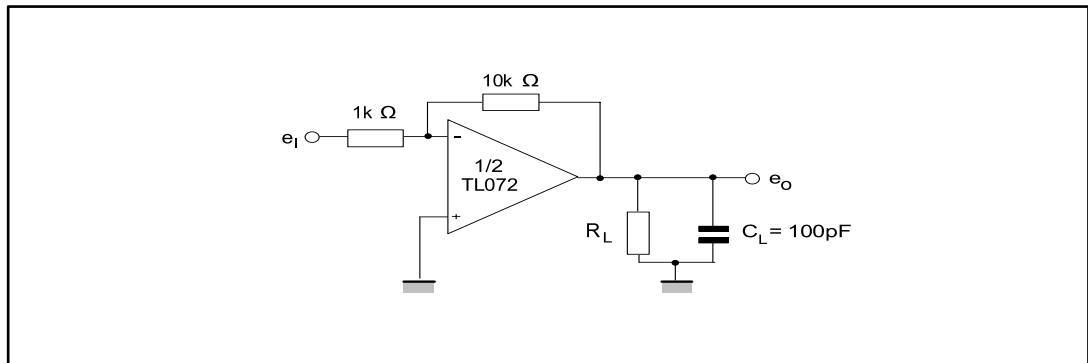
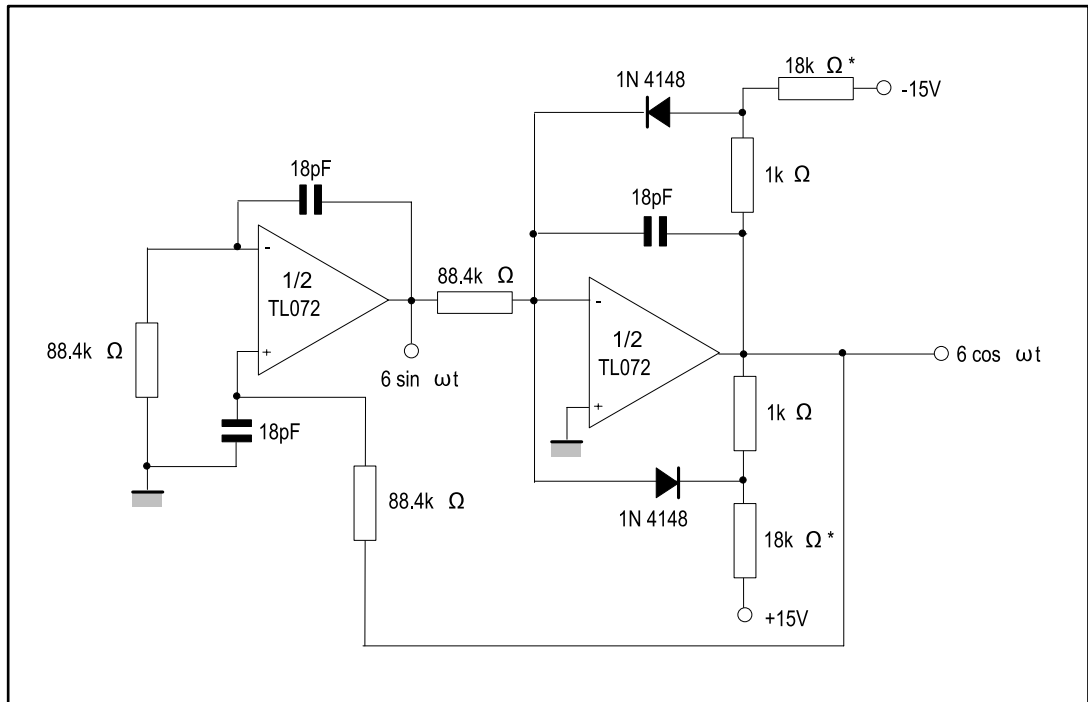

Figure 19: Gain-of-10 inverting amplifier



5 Typical application

Figure 20: 100 kHz quadruple oscillator



1. The resistor values of [Figure 20](#) may be adjusted for a symmetrical output

6 Package information

In order to meet environmental requirements, ST offers these devices in different grades of ECOPACK® packages, depending on their level of environmental compliance. ECOPACK® specifications, grade definitions and product status are available at: www.st.com. ECOPACK is an ST trademark.

6.1 SO8 package information

Figure 21: SO8 package mechanical drawing

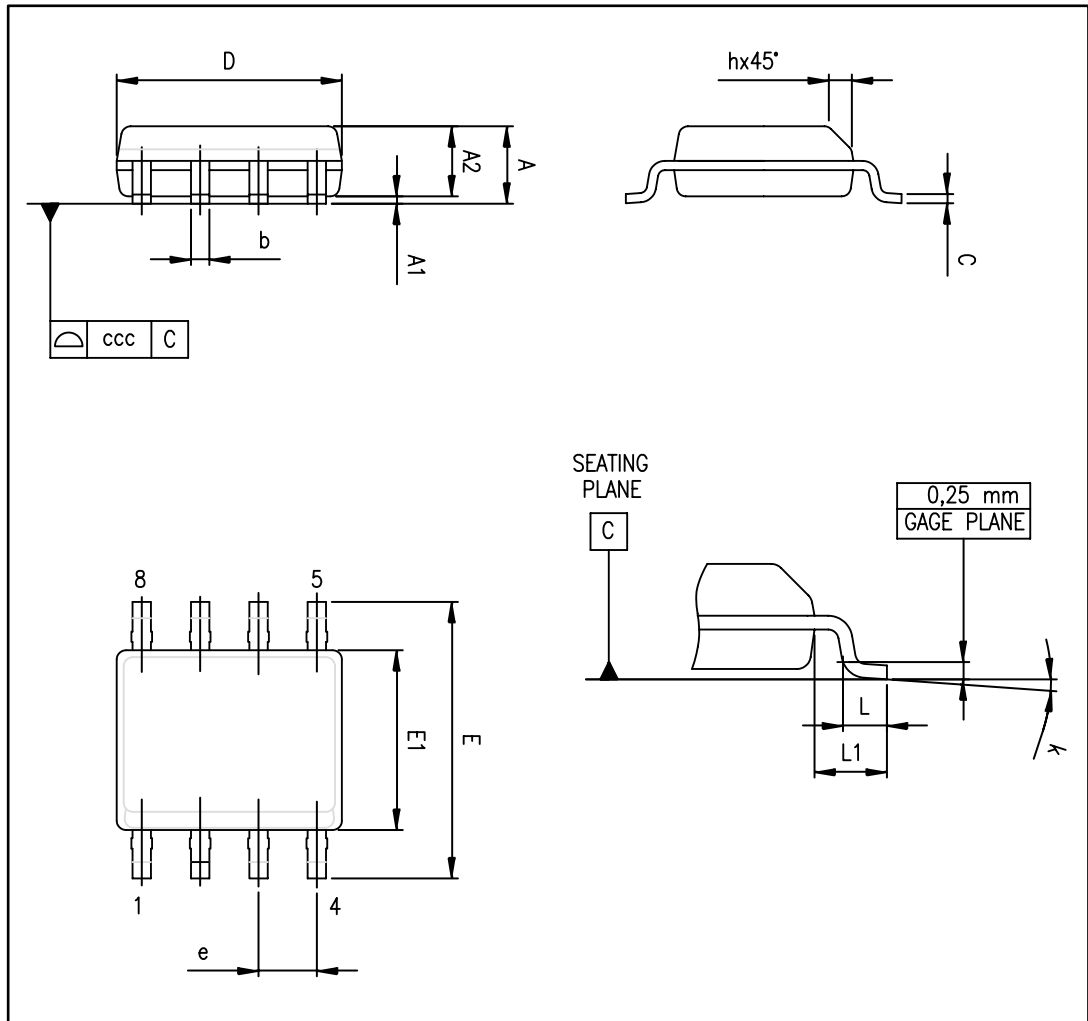

Table 4: SO8 package mechanical data

Ref.	Dimensions					
	Millimeters			Inches		
	Min.	Typ.	Max.	Min.	Typ.	Max.
A			1.75			0.069
A1	0.10		0.25	0.004		0.010
A2	1.25			0.049		
b	0.28		0.48	0.011		0.019
c	0.17		0.23	0.007		0.010
D	4.80	4.90	5.00	0.189	0.193	0.197
E	5.80	6.00	6.20	0.228	0.236	0.244
E1	3.80	3.90	4.00	0.150	0.154	0.157
e		1.27			0.050	
h	0.25		0.50	0.010		0.020
L	0.40		1.27	0.016		0.050
k	1°		8°	1°		8°
ccc			0.10			0.004

7 Ordering information

Table 5: Order codes

Order code	Temperature range	Package	Packing	Marking
TL072IDT	-40 °C, +125 °C	SO8	Tape and reel	072I
TL072AIDT				072AI
TL072BIDT				072BI
TL072CDT	0 °C, +70 °C			072C
TL072ACDT				072AC
TL072BCDT				072BC
TL072IYDT ⁽¹⁾	-40 °C, +125 °C	SO8 (automotive grade)		072IY
TL072AIYDT ⁽¹⁾				072AIY
TL072BIYDT ⁽¹⁾				072BIY

Notes:

⁽¹⁾ Qualified and characterized according to AEC Q100 and Q003 or equivalent, advanced screening according to AEC Q001 & Q002 or equivalent.

8 Revision history

Table 6: Document revision history

Date	Revision	Changes
28-Mar-2001	1	Initial release.
02-Apr-2004	2	Correction to pin connection diagram on cover page. Unpublished.
04-Dec-2006	3	Modified graphics in package mechanical data.
06-Mar-2007	4	Expanded order codes table and added automotive grade order codes. See Table 5: "Order codes" . Added thermal resistance and ESD tolerance in Table 1: "Absolute maximum ratings" . Added Table 2: "Operating conditions" . Updated package mechanical data to make it compliant with the latest JEDEC standards.
13-Mar-2008	5	ESD HBM value modified in AMR table. Re-ordered order codes table. Removed TL072BIY and TL072AIY order codes from order code table. Corrected footnote for automotive grade order codes in order codes table.
15-Jul-2008	6	Removed information concerning military temperature range (TL072Mx, TL072AMx, TL072BMx). Added order codes for automotive grade products in Table 5: "Order codes" .
04-Jul-2012	7	Removed part numbers TL072IYD, TL072AIYD, TL072BIYD. Updated Table 5: "Order codes" .
19-Jun-2014	8	Removed DIP8 package Added Related products Table 2: "Operating conditions" : temperature range for "I" versions changed from "-40 °C, +105 °C" to "-40 °C, +125 °C". Table 3: Electrical characteristics at VCC = ±15 V, Tamb = +25 °C (unless otherwise specified) : replaced DV _{io} with ΔV _{io} /ΔT. Table 5: "Order codes" : temperature range for "I" version order codes changed from "-40 °C, +105 °C" to "-40 °C, +125 °C"; removed tube packing and related order codes. Updated disclaimer

Please Read Carefully

Information in this document is provided solely in connection with ST products. STMicroelectronics NV and its subsidiaries ("ST") reserve the right to make changes, corrections, modifications or improvements, to this document, and the products and services described herein at any time, without notice.

All ST products are sold pursuant to ST's terms and conditions of sale.

Purchasers are solely responsible for the choice, selection and use of the ST products and services described herein, and ST assumes no liability whatsoever relating to the choice, selection or use of the ST products and services described herein.

No license, express or implied, by estoppel or otherwise, to any intellectual property rights is granted under this document. If any part of this document refers to any third party products or services it shall not be deemed a license grant by ST for the use of such third party products or services, or any intellectual property contained therein or considered as a warranty covering the use in any manner whatsoever of such third party products or services or any intellectual property contained therein.

UNLESS OTHERWISE SET FORTH IN ST'S TERMS AND CONDITIONS OF SALE ST DISCLAIMS ANY EXPRESS OR IMPLIED WARRANTY WITH RESPECT TO THE USE AND/OR SALE OF ST PRODUCTS INCLUDING WITHOUT LIMITATION IMPLIED WARRANTIES OF MERCHANTABILITY, FITNESS FOR A PARTICULAR PURPOSE (AND THEIR EQUIVALENTS UNDER THE LAWS OF ANY JURISDICTION), OR INFRINGEMENT OF ANY PATENT, COPYRIGHT OR OTHER INTELLECTUAL PROPERTY RIGHT.

ST PRODUCTS ARE NOT DESIGNED OR AUTHORIZED FOR USE IN: (A) SAFETY CRITICAL APPLICATIONS SUCH AS LIFE SUPPORTING, ACTIVE IMPLANTED DEVICES OR SYSTEMS WITH PRODUCT FUNCTIONAL SAFETY REQUIREMENTS; (B) AERONAUTIC APPLICATIONS; (C) AUTOMOTIVE APPLICATIONS OR ENVIRONMENTS, AND/OR (D) AEROSPACE APPLICATIONS OR ENVIRONMENTS. WHERE ST PRODUCTS ARE NOT DESIGNED FOR SUCH USE, THE PURCHASER SHALL USE PRODUCTS AT PURCHASER'S SOLE RISK, EVEN IF ST HAS BEEN INFORMED IN WRITING OF SUCH USAGE, UNLESS A PRODUCT IS EXPRESSLY DESIGNATED BY ST AS BEING INTENDED FOR "AUTOMOTIVE, AUTOMOTIVE SAFETY OR MEDICAL" INDUSTRY DOMAINS ACCORDING TO ST PRODUCT DESIGN SPECIFICATIONS. PRODUCTS FORMALLY ESCC, QML OR JAN QUALIFIED ARE DEEMED SUITABLE FOR USE IN AEROSPACE BY THE CORRESPONDING GOVERNMENTAL AGENCY.

Resale of ST products with provisions different from the statements and/or technical features set forth in this document shall immediately void any warranty granted by ST for the ST product or service described herein and shall not create or extend in any manner whatsoever, any liability of ST.

ST and the ST logo are trademarks or registered trademarks of ST in various countries.

Information in this document supersedes and replaces all information previously supplied.

The ST logo is a registered trademark of STMicroelectronics. All other names are the property of their respective owners.

© 2014 STMicroelectronics - All rights reserved

STMicroelectronics group of companies

Australia - Belgium - Brazil - Canada - China - Czech Republic - Finland - France - Germany - Hong Kong - India - Israel - Italy - Japan - Malaysia - Malta - Morocco - Philippines - Singapore - Spain - Sweden - Switzerland - United Kingdom - United States of America

www.st.com