

ON TAT INDUSTRIAL COMPANY

SPECIFICATION FOR LCD MODULE

Customer : _____

Product Model: KD50G21-40NT-A1

Sample code: _____

Designed by	Checked by	Approved by

Final Approval by Customer

<input type="checkbox"/> LCM Machinery OK Checked By _____	<input type="checkbox"/> LCM OK
<input type="checkbox"/> LCM Display OK Checked By _____	<input type="checkbox"/> NG, Problem survey: Approved By _____

※The specification of "TBD" should refer to the measured value of sample . If there is difference between the design specification and measured value, we naturally shall negotiate and agree to solution with customer.

Contents

No.	Item	Page
1.	Numbering System	4/24
2	Scope	5/24
3	Normative Reference	5/24
4	Definitions	5/24
5	Technology Specifications	7/24
6	Circuit block diagram	11/24
7	Reliability Test Condition and Methods	15/21
8	Inspection standard	16/21
9	Handling Precautions	22/24
10	Precaution for use	23/24
11	Dimensional Outline	24/24

1 Numbering System

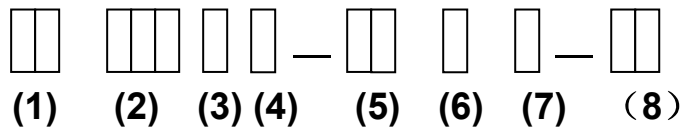

No	Definition	Specifications
(1)	TFT LCM Productor No.	On Tat Industrial Company
(2)	Display monitor opposite angle line size	Unit :mm or mmm (size <10 inch: takes two integers ; size >=10 inch: takes three integers)
(3)	Productor Types	D---- Digital photo frame / DVD G ----GPS M---- MP P ----Mobil-Phone . . .
(4)	Productor Development Series No.	By two figures characters expression from 01 to 99
(5)	Interface PIN Number	By two figures characters expression from 01 to 99
(6)	With Touch Panel Or Not	T----With T/P ; N----Without T/P
(7)	LCD Type	A----AUO ; M----CMO ; C----CPT; P----PVI; L----LG; W----Wintek; H----HSD; T----Tianma; Y----Hydis; I----Hitach; S----Sharp. . .
(8)	Productor Development edition No.	By The English litters : A 1~ Z9

2 Scope

This specification applies to the TFT LCD module which is designed and manufactured by LCM Factory of On Tat Industrial Company

3 Normative Reference

GB/T4619-1996 《Liquid Crystal Display Test Method》

GB/T2424 《Basic environmental Testing Procedures for Electric and Electronic Products.》

GB/T2423 《Basic Testing Procedures for Electric and Electronic Products》

IEC61747-1 《SIXTH PART GB2828`2829-87 《National Standard of PRC》

4 Definitions

4.1 Definitions of Vop

The definitions of threshold voltage V_{th1} , V_{th2} the following typical waveforms are applied on liquid crystal by the method of equalized voltage for each duty and bias.

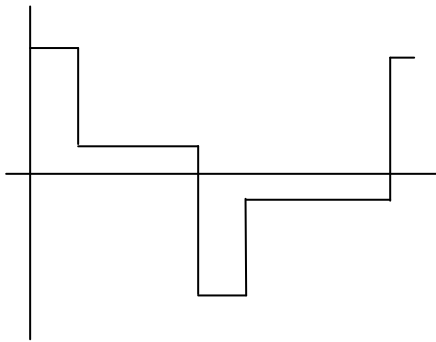

【 selected waveform 】

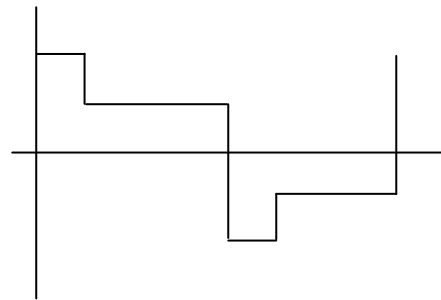

【 non-selected waveform 】

① V_{th1} : The voltage which the brightness of segment indicates 50% of saturated value on the conditions of selected waveform

($f_r=80\text{Hz}$, $\Phi=10^\circ$ $\theta=270^\circ$ at 25°C)

② V_{th2} : The voltage which the brightness of segment indicates 50% of saturated value on the conditions of non-selected waveform

($f_r=80\text{Hz}$, $\Phi=10^\circ$ $\theta=270^\circ$ at 25°C)

③ V_{op} : $(V_{th1}(50\%)+V_{th2}(50\%))/2$ ($f_r=80\text{Hz}$, $\Phi=10^\circ$ $\theta=270^\circ$ at 25°C)

4.2 Definition of Response Time T_r , T_d

① T_r : The time required which the brightness of segment becomes 10% from 100% when waveform is switched to selected one from non-selected one. ($f_r=80\text{Hz}$, $\Phi=10^\circ$ $\theta=270^\circ$ at 25°C)

② T_d : The time required which the brightness of segment becomes 90% from 10% when waveform is switched to selected one from selected one. ($f_r=80\text{Hz}$, $\Phi=10^\circ$ $\theta=270^\circ$ at 25°C)

4.3 Definition of Contrast Ratio Cr

$Cr=A/B$

- ① A: Segments brightness in case of non-selected waveform
- ② B: Segments brightness in case of selected waveform

4.4 Definition of Angle and Viewing Range

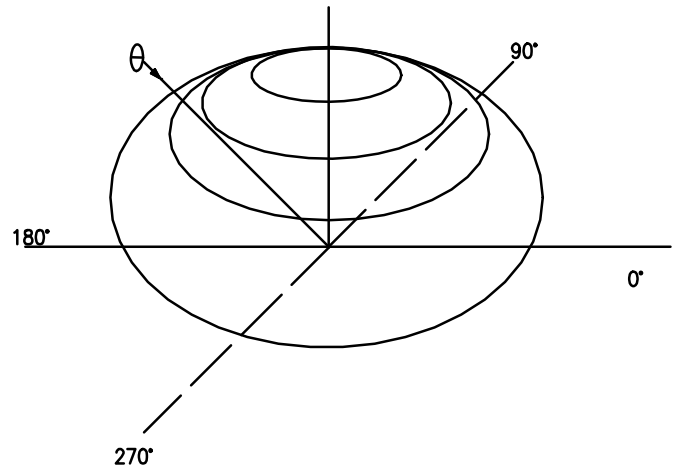
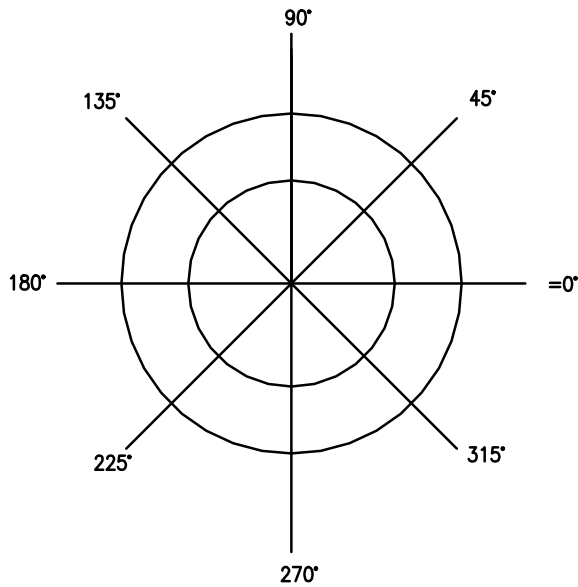

Angular Graph: Constrast Ratio

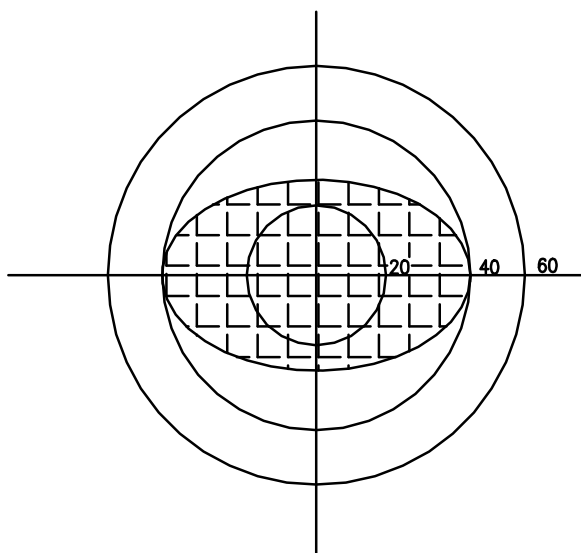

Such as:
 Viewing Angle Range:
 80(Cr>2) Horizontal
 70(Cr>2) Vertical

5 Technology Specifications

5.1 Feature

This single-display module is suitable for use in Multimedia Player products. The LCD adopts one backlight with High brightness 12-lamps white LED.

- 1) Construction: 5.0 inch a-Si color TFT-LCD ,White LED backlight.
- 2) LCD:
 - 2.1 Amorphous-TFT 5.0 inch display, transmissive, normally white type.
 - 2.2 800(RGB)×480 dots Matrix.
 - 2.3 Narrow-contact ledge technique.
 - 2.4 LCD Driver IC: HX8264D × 1 and HX8664B × 1.
- 3) Low cross talk by frame rate modulation.
- 4) RGB interface.
- 5) Video signal interface: Parallel RGB or serial.

5.2 Mechanical Specifications

Item	Specifications	Unit
Dimensional outline	120.70(W) ×75.8(H)×3.10 Max(T)	mm
Active area	108.0(W) ×64.8 (H)	mm
Pixel size	135(W) ×135(H)	um
Resolution	800(RGB) × 480	pixel
Luminance for LCM	200	cd/m ²

5.3 Absolute Max. Rating

Item	Symbol	Value			Unit	Remark
		Min	typ	Max		
Logic power supply	DVDD	3.0	3.3	3.6	V	
Driver power supply	AVDD	11	12	13	V	
Input high voltage	V _{IH}	0.7DVDD	-	DVDD	V	
Input low voltage	V _{IL}	0	-	0.3DVDD	V	
Operating temperature	T _{OPR}	-20		+70	°C	
Storage temperature	T _{STG}	-30		+80	°C	

5.4 Electrical Characteristics (VSS=0V,Ta=-20 to 70°C)

Parameter	Symbol	Applicable pin	Condition	Spec.			Unit
				Min.	Typ.	Max.	
Input H voltage	V _{IH}	All input pins ⁽²⁾	-	0.7VDD	-	VDD	V
Input L voltage	V _{IL}	All input pins ⁽²⁾	-	VSS	-	0.3VDD	
Input H voltage	V _{IH}	/XAO		0.8VDD	-	VDD	
Input L voltage	V _{IL}	/XAO		VSS	-	0.2VDD	
Output H voltage	V _{OH}	STV1,2	I _{OH} =40μA	VDD-0.4	-	VDD	
Output L voltage	V _{OL}	STV1,2	I _{OL} =40μA	VSS	-	VSS+0.4	
Output H resistance	R _{OH}	OUT0~ OUT961	V _{OUT} = VGH-0.5V	-	-	1000	Ω
Output L resistance	R _{OL}	OUT0~ OUT961	V _{OUT} = VEE+0.5V	-	-	1000	Ω
Input leakage current	I _{IN}	Note ⁽²⁾	-	-5.0	-	+5.0	μA
Pull high resistance	R _{PU}	/XAO,MODE, SEL	VDD=3.3V, TA=25C	70	160	400	kΩ
VGH Power consumption	I _{VGH}	-	Note ⁽¹⁾	-	-	200	μA
VDD Power consumption	I _{VDD}	-		-	-	200	

Note: (1) Power consumption in the following condition:
 Output no load, VGH=20V, VEE=-8V, VDD=3.0V, V_{IH}=VDD, V_{IL}=VSS, F_{CPV}=50KHz, OE=V_{IL}, /XAO=V_{IH}.
 (2) All input pins except /XAO, MODE, SEL

OKB/S

Parameter	Symbol	Condition	Spec.			Unit
			Min.	Typ.	Max.	
CPV period	t _{CPV}	-	5	-	-	μs
CPV pulse width	t _{CPVH} , t _{CPVL}	50% duty cycle	2.5	-	-	
OE pulse width	t _{WOE}	-	1	-	-	
/XAO pulse width	t _{WXAO}	-	30	-	-	
Data setup time	t _{SU}	-	0.3	-	-	
Data hold time	t _{HD}	-	0.3	-	-	
CPV to output delay time	t _{PD1}	CL=200pF	-	-	0.9	
Start pulse output delay time	t _{PD2}	Loading=20pF	-	-	0.5	
OE to output delay time	t _{PD3}	CL=200pF	-	-	0.9	
/XAO to output delay time	t _{PD4}	CL=200pF	-	-	50	

Note: The measurement point for all of above signals is at 50% of input/output amplitude under Typical condition.

5.5 Optical specifications

Ta=25°C

Item	Symbol	Condition	Min	Typ.	Max	Unit	Remark	
View Angle	θT	$CR \geq 10$	40	50	-	Degree	Note 2	
	θB		60	70	-			
	θL		60	70	-			
	θR		60	70	-			
Contrast Ratio	CR	$\theta=0^\circ$	400	500	-	-	Note1	
Response Time	T_{ON}	25°C	-	20	25	ms	Note1	
	T_{OFF}						Note4	
Color Filter Chromaticity	White	C-light	x	0.260	0.310	0.360	-	Just CF, without polarizer
			y	0.280	0.330	0.380		
	Red		x	0.540	0.590	0.640		
			y	0.300	0.350	0.400		
	Green		x	0.298	0.348	0.398		
			y	0.520	0.570	0.620		
	Blue		x	0.095	0.145	0.195		
			y	0.060	0.110	0.160		
NTSC	-	-	45	50	-	%	Note 5	
Transmittance	L	-	3.8	4.1	-	%	Note1	

Test Conditions:

1. The ambient temperature is 25°C.
2. The test systems refer to Note 1 and Note 2.
3. Viewing angle, contrast ratio and transmittance are test the panel include EWW polarizer (NWF-LNSW) with LED backlight.
4. The value of transmittance in this spec is a reference which will be affected by polarizer finally.

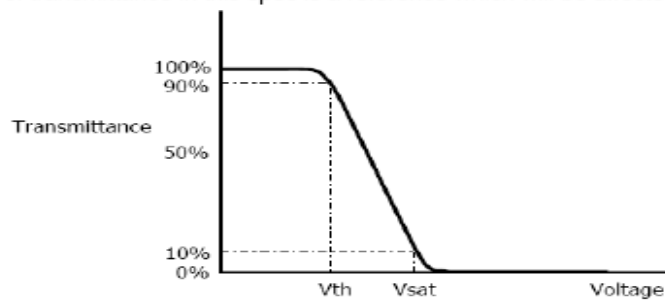
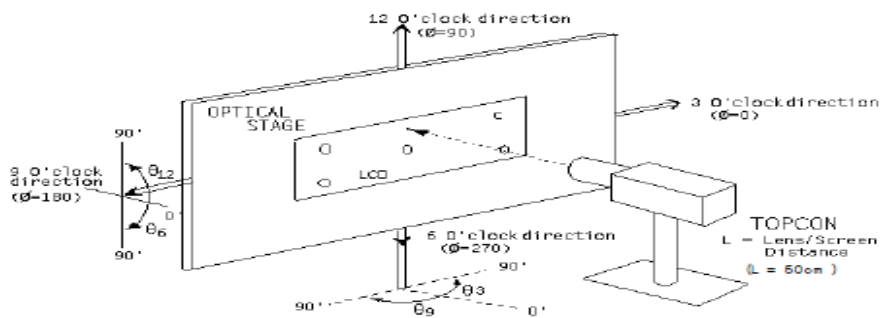

Figure 2. Measurement Set Up



5.6 LED back light specification (12 White Chips)

Item	Symbol	Condition	Min	Typ	Max	Unit
Forward Voltage	V _f	I _f =40mA	18	19.2	20.4	V
Uniformity (with L/G)	Δ B _p	I _f =40mA	80	-	-	%
Luminance for BL	L _v	I _f =40mA	4800	-	-	cd/m ²

LED CIRCUIT

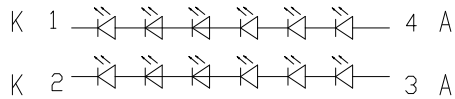

5.7 Interface PinConnections

PIN NO.	Symbol	Description
1	LED-K	LED backlight(Cathode)
2	LED-A	LED backlight(anode)
3	GND	Ground
4	VDD	Power supply (Digital +3.0V)
5-12	R0-R7	Red Data
13-20	G0-G7	Green Data
21-28	B0-B7	Blue Data
29	GND	Ground
30	CLK	Clock (<u>Latch data at clk falling edge</u>)
31	DISP	Display on/off
32	HSYNC	Horizontal sync input in RGB mode (short to GND if not used)
33	VSYNC	Vertical sync input in RGB mode (short to GND if not used)
34	DEN	Data Enable
35	NC	NC
36	GND	Ground
37	NC (XR)	NC(Touch panel coordinate in the right side of envisage drawing)
38	NC (YD)	NC(Touch panel coordinate in the down side of envisage drawing)
39	NC (XL)	NC(Touch panel coordinate in the left side of envisage drawing)
40	NC (YU)	NC(Touch panel coordinate in the up side of envisage drawing)

6 Signal timing diagram and Circuit block diagram

6.1 Circuit block diagram

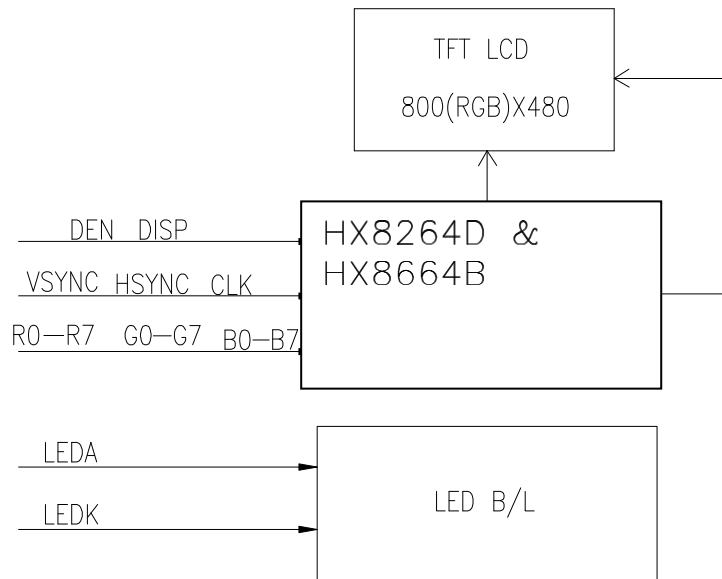

6.2 Signal Timing Diagram

6.2.1 Power ON/OFF Sequence

HX8264-D02 has a power on/off sequence control function. In order to prevent IC from power on reset fail, the rising time (T_{POR}) of the digital power supply VDD should be maintained within the given specifications. Please refer to “AC Characteristics” for more detail on timing.

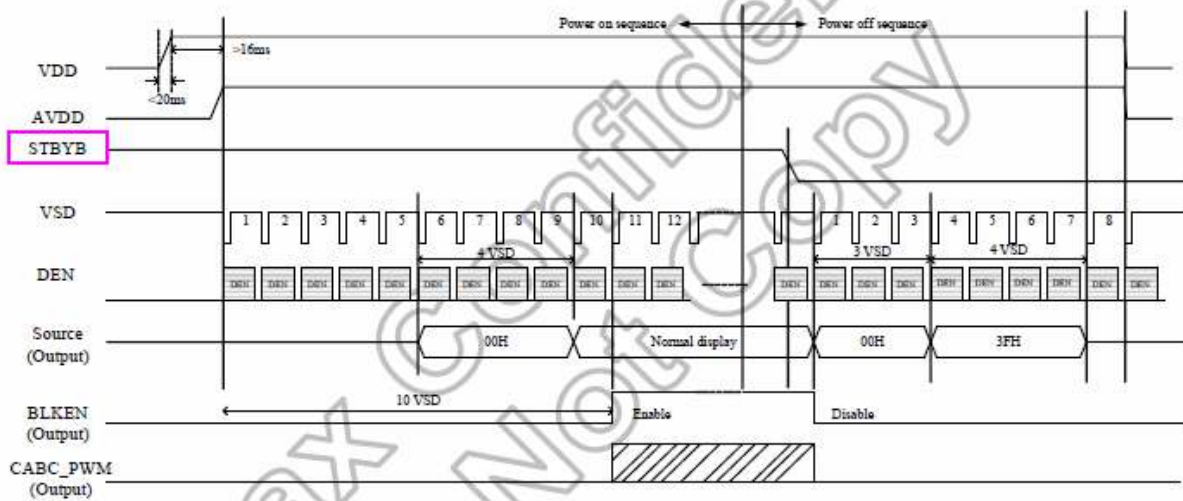

6.2.2 Reset timing

The reset input must be held for at least 1ms after power is stable.

Hardware reset timing

PARAMETER	Symbol	Spec.			Unit
		Min.	Typ.	Max.	
RESETB low pulse width	T_{rstw}	10	-	-	μs
Negative noise pulse width	T_{nr}	-	-	2	μs
Reset start time	T_{st}	2	-	-	μs

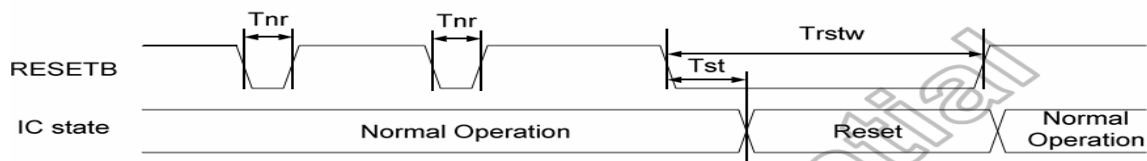

- Vertical timing

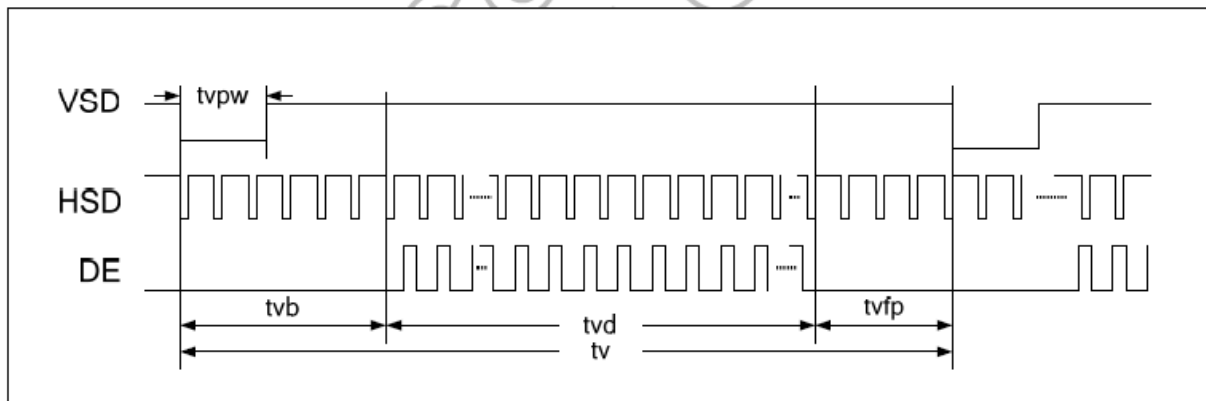

- Horizontal timing

Parameter	Symbol	Spec.			Unit
		Min.	Typ.	Max.	
Horizontal Display Area	thd		800		DCLK
DCLK frequency	fclk	-	30	50	MHz
One Horizontal Line	th	889	928	1143	DCLK
HS pulse width	thpw	1	48	255	DCLK
HS Back Porch (Blanking)	thb		88		DCLK
HS Front Porch	thfp	1	40	255	DCLK
DE mode Blanking	th-thd	85	128	512	DCLK

- Vertical timing

Parameter	Symbol	Spec.			Unit
		Min.	Typ.	Max.	
Vertical Display Area	tvd		480		T_H
VS period time	tv	513	525	767	T_H
VS pulse width	tvpw	3	3	255	T_H
VS Back Porch (Blanking)	tvb		32		T_H
VS Front Porch	tvfp	1	13	255	T_H
DE mode Blanking	tv-tvd	4	45	255	T_H

6.2.4 Driver Timing Control

Parameter	Symbol	Min.	Typ.	Max.	Unit	Conditions
CLKIN Frequency	Fclk	-	40	50	MHz	VDD=3.0V~3.6V
CLKIN Cycle Time	Tclk	20	25	-	ns	-
CLKIN Pulse Duty	Tcwh	40	50	60	%	Tclk
Time from HSD to Source Output	Thso		64		CLKIN	-
Time from HSD to LD	Thld		64		CLKIN	-
Time from HSD to STV	Thstv		2		CLKIN	-
Time from HSD to CKV	Thckv		20		CLKIN	-
Time from HSD to OEV	Thoev		4		CLKIN	-
LD Pulse Width	Twld		10		CLKIN	-
CKV Pulse Width	Twckv		66		CLKIN	-
OEV Pulse Width	Twoev		74		CLKIN	-

Vertical timing diagram HV (Cascade)

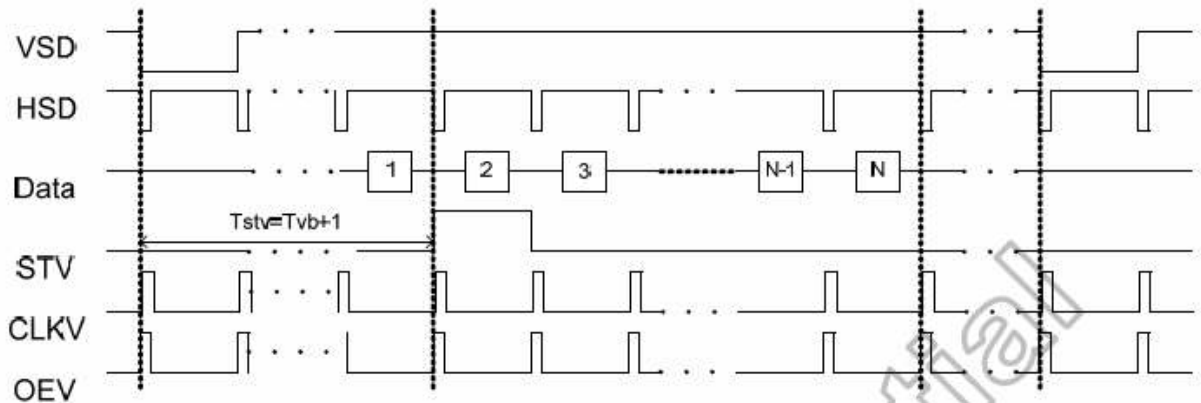

Vertical timing diagram DE (Cascade)

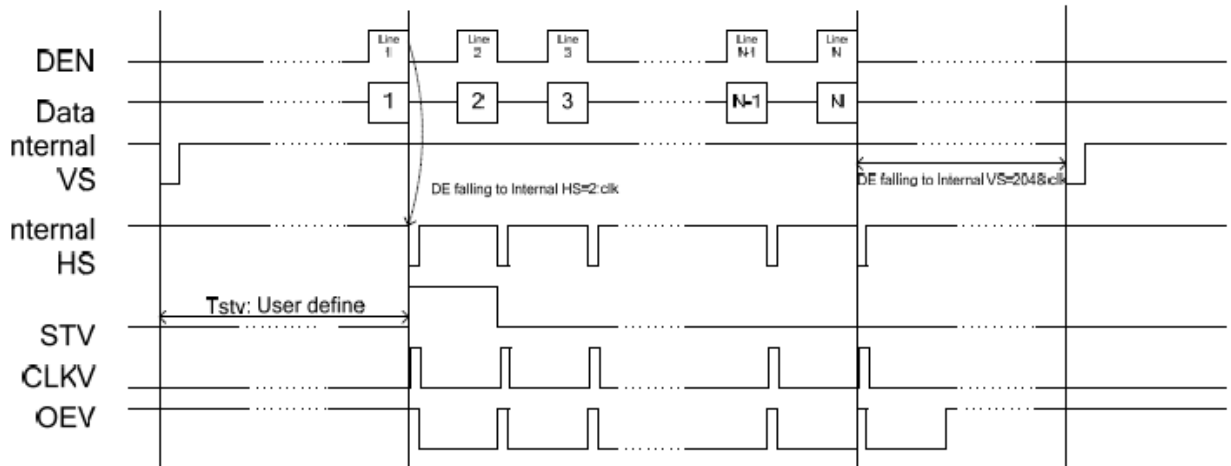

Gate output timing diagram (Cascade)

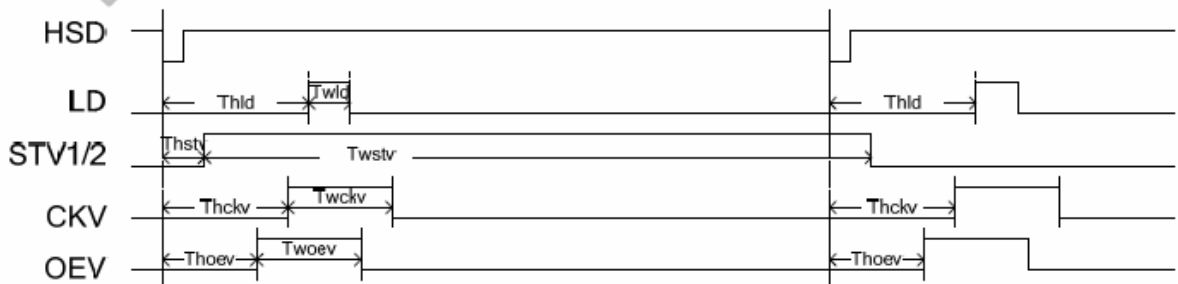

7 Reliability Test Conditions And Methods

NO	Item	Condition	Method
1	High / Low Temperature Storage	80°C/-30°C 120hrs	Check and record every 48Hrs
2	High / Low Temperature Life	70°C/-20°C 120hrs (operating mode)	Check and record every 48Hrs
3	High Temperature、High Humidity Operating	60°C,90% RH, 96Hrs	Check and record every 48hrs
4	Thermal Shock	-30°C(30Min) → 25°C(5Min) → 80°C(30Min) (conversion time, : 5 sec) 20 cycles	Each 10 cycles end , check
5	Vibration	10Hz~55Hz~10Hz Amplitude: 1.5mm 2hrs for each direction(X,Y,Z)	Each direction end, Check the Appearance and Electrical Characteristics
6	Static Electricity	Gap mood: ±1KV~±8KV (10 times air discharge with positive/negative voltage voltage gap : 1kv) Touch mood: ±1KV~±4KV	Each discharge end, Check the Electrical Characteristics
7	Curve	60 Thousand times, 40 times/min 150° (according to die if exist)	Check and record every 2~4 thousand times
8	Slump	Free faller movement for each side、cording、 angle (75cm High、 6 sides、 2 angle、 2 cording)	End

8 Inspection standard

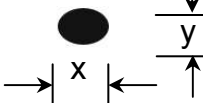
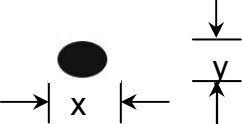
No	Item	Criterion																			
01	Outline Dimension	In accord with drawing																			
02	Position-finding Dimension Assemble Dimension	In accord with drawing																			
03	LCD black spots, white spots (Round type)	<p>Round type: non display</p> <p>3.1 Small area LCD</p> <p style="text-align: right;">Unit : mm</p>  <table border="1" data-bbox="778 750 1300 1064"> <thead> <tr> <th>Dimension</th> <th>Qualified Quantity</th> </tr> </thead> <tbody> <tr> <td>$D \leq 0.1$</td> <td>Ignore</td> </tr> <tr> <td>$0.1 < D \leq 0.15$</td> <td>2</td> </tr> <tr> <td>$D > 0.15$</td> <td>0</td> </tr> </tbody> </table> <p>3.2 Large area LCD</p>  <table border="1" data-bbox="770 1243 1300 1624"> <thead> <tr> <th>Dimension</th> <th>Qualified Quantity</th> </tr> </thead> <tbody> <tr> <td>$D \leq 0.1$</td> <td>Ignore</td> </tr> <tr> <td>$0.1 < D \leq 0.15$</td> <td>2</td> </tr> <tr> <td>$0.15 < D \leq 0.20$</td> <td>1</td> </tr> <tr> <td>$D > 0.20$</td> <td>0</td> </tr> </tbody> </table> <p>C-STN : if $D > 0.1$, unqualified</p>	Dimension	Qualified Quantity	$D \leq 0.1$	Ignore	$0.1 < D \leq 0.15$	2	$D > 0.15$	0	Dimension	Qualified Quantity	$D \leq 0.1$	Ignore	$0.1 < D \leq 0.15$	2	$0.15 < D \leq 0.20$	1	$D > 0.20$	0	
Dimension	Qualified Quantity																				
$D \leq 0.1$	Ignore																				
$0.1 < D \leq 0.15$	2																				
$D > 0.15$	0																				
Dimension	Qualified Quantity																				
$D \leq 0.1$	Ignore																				
$0.1 < D \leq 0.15$	2																				
$0.15 < D \leq 0.20$	1																				
$D > 0.20$	0																				

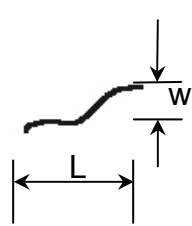
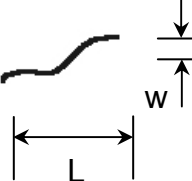
04	LCD Black spots, white spots (Line Style)	Unit : mm		4.1	Small	area	LCD													
			<table border="1"> <thead> <tr> <th>Length</th> <th>Width</th> <th>Qualified Quantity</th> </tr> </thead> <tbody> <tr> <td>-</td> <td>≤ 0.015</td> <td>Ignore</td> </tr> <tr> <td>≤ 1.0</td> <td rowspan="2">$0.015 < W \leq 0.025$</td> <td>2</td> </tr> <tr> <td>≤ 2.0</td> <td>1</td> </tr> <tr> <td>≤ 1.0</td> <td>$0.025 < W \leq 0.05$</td> <td>1</td> </tr> <tr> <td>-</td> <td>$D > 0.05$</td> <td>According to circle</td> </tr> </tbody> </table>	Length	Width	Qualified Quantity	-	≤ 0.015	Ignore	≤ 1.0	$0.015 < W \leq 0.025$	2	≤ 2.0	1	≤ 1.0	$0.025 < W \leq 0.05$	1	-	$D > 0.05$	According to circle
Length	Width	Qualified Quantity																		
-	≤ 0.015	Ignore																		
≤ 1.0	$0.015 < W \leq 0.025$	2																		
≤ 2.0		1																		
≤ 1.0	$0.025 < W \leq 0.05$	1																		
-	$D > 0.05$	According to circle																		
		4.2 Large area LCD																		
			<table border="1"> <thead> <tr> <th>Length</th> <th>Width</th> <th>Qualified Quantity</th> </tr> </thead> <tbody> <tr> <td>-</td> <td>≤ 0.015</td> <td>Ignore</td> </tr> <tr> <td>≤ 2.0</td> <td rowspan="2">$0.015 < W \leq 0.025$</td> <td>2</td> </tr> <tr> <td>≤ 1.0</td> <td>1</td> </tr> <tr> <td>-</td> <td>$D > 0.05$</td> <td>According to circle</td> </tr> </tbody> </table>	Length	Width	Qualified Quantity	-	≤ 0.015	Ignore	≤ 2.0	$0.015 < W \leq 0.025$	2	≤ 1.0	1	-	$D > 0.05$	According to circle			
Length	Width	Qualified Quantity																		
-	≤ 0.015	Ignore																		
≤ 2.0	$0.015 < W \leq 0.025$	2																		
≤ 1.0		1																		
-	$D > 0.05$	According to circle																		
		CSTN : If $W \geq 0.015$, unqualified Ignore beyond viewing area																		
05	LCD Scratch 、 Threadlike Fiber	Same to NO.3 circle sightline and surface of LCD is vertical (2)Same to NO.3 line style																		
06	POL	It is not admissible that POL is beyond the edge of glass, else, unqualified. It is essential that POL is over the 50 percent of width of frame , else ,unqualified. According to the drawing in case of special definition.																		
07	IC/FPC Bonding	Scratch		Reject																

		Intensity Of Adhesion	If lower than specification, reject	
		Gold Fold Twist	Reject	
07	IC/FPC Bonding	Silicon	According to outline, no gold outside, seal can not be higher than LCD	
		FPC Gold Sever	Reject	
08	SMT	Lack of Component, Polarity Inverse	If exist, reject	
		Leak Solder, Virtual Solder	If exist, reject	
		Short Circuit In Solder Point	If exist, reject	
		Tin Ball	If exist, reject	
		Tin Acumination	If visual, reject	
		Height Solder Point	If higher 0.5mm than component. reject	
		Height of component	Either side higher 0.5mm than component, reject	

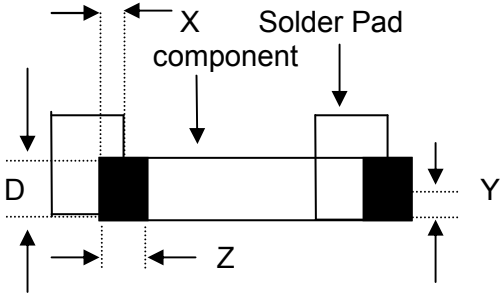
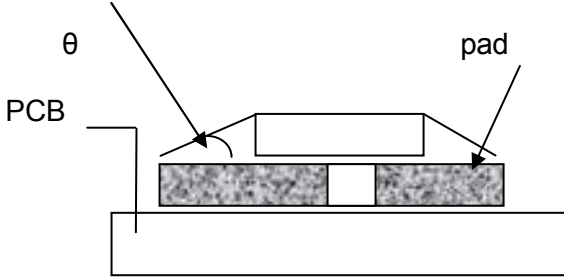
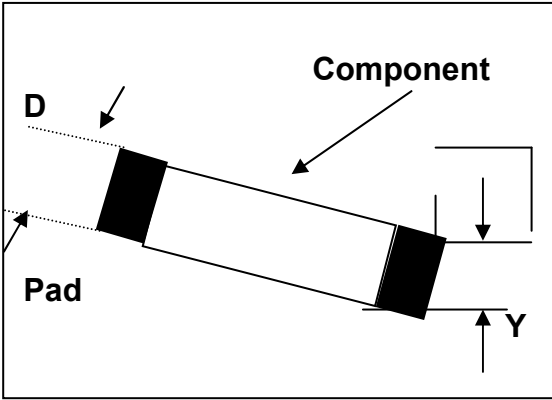
		Component Shift	 <p>$X < 3/4Z$ $y > 1/3D$</p> <p>reject reject</p>
08	SMT	Few Tin	 <p>If $\theta \leq 20^\circ$ reject</p>
		Component Deflection	 <p>If $Y > 1/3D$ reject</p>
		Component Carcass Sideways	Reject

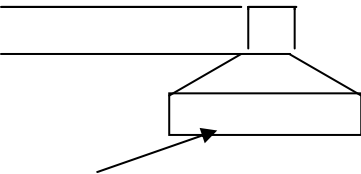
		Component Carcass Sideways	If exist with visual inspection , reject	
		Lot Tin	A: Tin accrete the solder side completely , hollowly ,Ok B: Tin accrete the solder side completely , full circle arc , ok C: Jointing include whole solder side, height of tin>50 percent of height of component, reject	
		Few Tin	A: Tin accrete the solder side completely , hollowly ,Ok B: height of tin > 1/3 of solder side of component , ok C: height of tin ≤ 1/3 of solder side of component, reject	
08	SMT	<p style="text-align: center;">Normal</p>  <p style="text-align: center;">Jointing side</p>		
		Short circuit 、 Open circuit	Forbid	
09	Light	Quality of CSTN Display	1、 Rolling strake with visual inspection, forbid 2、 Differentness of color in viewing area with visual inspection (full white、 red、 green、 blue), forbid 3 、 Display change with visual inspection , forbid	

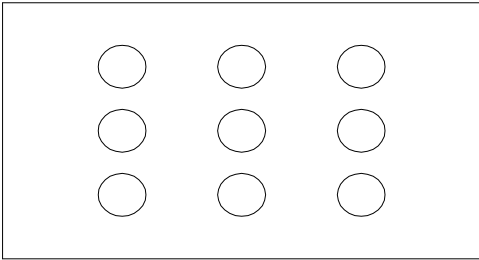
10	Color Of CIE Coordinate		x	y	Drive LCD under normal condition, 25°C $\phi=0$ $\theta=0$ Test white, red, green blue with DMS Record
		white	± 0.05	± 0.05	
		Red	± 0.05	± 0.05	
		Green	± 0.05	± 0.05	
		Blue	± 0.05	± 0.05	
		According to the specification or sample customer have approved			
11	Brightness	In accord with product specification	Drive condition is according to specification Measure location is in Follow Picture 3、 Adjust brightness instrument to zero , burrow against the surface of LCD , press “measure” , record when the display is steady. (YOKOGAWA-3298)		
			 <p style="text-align: center;">Measure location</p>		
12	CR (Max)	According to specification	According to product specification Measure instrument (DMS-501)		
13	Response time	According to specification	According to product specification Measure instrument (DMS-501)		
14	Viewing angle	According to specification	According to product specification Measure instrument (DMS-501)		
15	Vibration、 Ring	Compare with the sample customer supply	Compare with the sample customer supply when assemble		
16	Frequency Of FPC Bend	According to the use of product (main FPC of foldaway cell phone ≥ 6 thousand)	Measure instrument Bend angle : 150° Fix FPC in the casement when customer supply		

9 Handling Precautions

9.1 Mounting method

The LCD panel of Daxian LCD module consists of two thin glass plates with polarizers which easily be damaged. And since the module is so constructed as to be fixed by utilizing fitting holes in the printed circuit board.

Extreme care should be needed when handling the LCD modules.

9.2 Caution of LCD handling and cleaning

When cleaning the display surface, Use soft cloth with solvent [recommended below] and wipe lightly

- Isopropyl alcohol
- Ethyl alcohol

Do not wipe the display surface with dry or hard materials that will damage the polarizer surface.

Do not use the following solvent:

- Water
- Aromatics

Do not wipe ITO pad area with the dry or hard materials that will damage the ITO patterns

Do not use the following solvent on the pad or prevent it from being contaminated:

- Soldering flux
- Chlorine (Cl) , Sulfur (S)

If goods were sent without being silicon coated on the pad, ITO patterns could be damaged due to the corrosion as time goes on.

If ITO corrosion happens by miss-handling or using some materials such as Chlorine (Cl), Sulfur (S) from customer, Responsibility is on customer.

9.3 Caution against static charge

The LCD module uses C-MOS LSI drivers, so we recommend that you:

Connect any unused input terminal to V_{dd} or V_{ss}, do not input any signals before power is turned on, and ground your body, work/assembly areas, assembly equipment to protect against static electricity.

9.4 packing

- Module employs LCD elements and must be treated as such.
- Avoid intense shock and falls from a height.
- To prevent modules from degradation, do not operate or store them exposed direct to sunshine or high temperature/humidity

9.5 Caution for operation

- It is an indispensable condition to drive LCD's within the specified voltage limit since the higher voltage than the limit causes the shorter LCD life.
- An electrochemical reaction due to direct current causes LCD's undesirable deterioration, so that the use of direct current drive should be avoided.
- Response time will be extremely delayed at lower temperature than the operating temperature range and on the other hand at higher temperature LCD's show dark color in them. However those phenomena do not mean malfunction or out of order with LCD's, which will come back in the specified operation temperature.
- If the display area is pushed hard during operation, some font will be abnormally

displayed but it resumes normal condition after turning off once.

- A slight dew depositing on terminals is a cause for electro-chemical reaction resulting in terminal open circuit.
Usage under the maximum operating temperature, 50%Rh or less is required.

9.6 storage

In the case of storing for a long period of time for instance, for years for the purpose or replacement use, the following ways are recommended.

- Storage in a polyethylene bag with the opening sealed so as not to enter fresh air outside in it . And with no desiccant.
- Placing in a dark place where neither exposure to direct sunlight nor light's keeping the storage temperature range.
- Storing with no touch on polarizer surface by the anything else.
[It is recommended to store them as they have been contained in the inner container at the time of delivery from us

9.7 Safety

- It is recommendable to crash damaged or unnecessary LCD's into pieces and wash off liquid crystal by either of solvents such as acetone and ethanol, which should be burned up later.
- When any liquid leaked out of a damaged glass cell comes in contact with your hands, please wash it off well with soap and water

10 Precaution for use

10.1

A limit sample should be provided by the both parties on an occasion when the both parties agreed its necessity. Judgment by a limit sample shall take effect after the limit sample has been established and confirmed by the both parties.

10.2

On the following occasions, the handing of problem should be decided through discussion and agreement between responsible of the both parties.

- When a question is arisen in this specification
- When a new problem is arisen which is not specified in this specifications
- When an inspection specifications change or operating condition change in customer is reported to Daxian , and some problem is arisen in this specification due to the change
- When a new problem is arisen at the customer's operating set for sample evaluation in the customer site.

11 Dimensional Outline

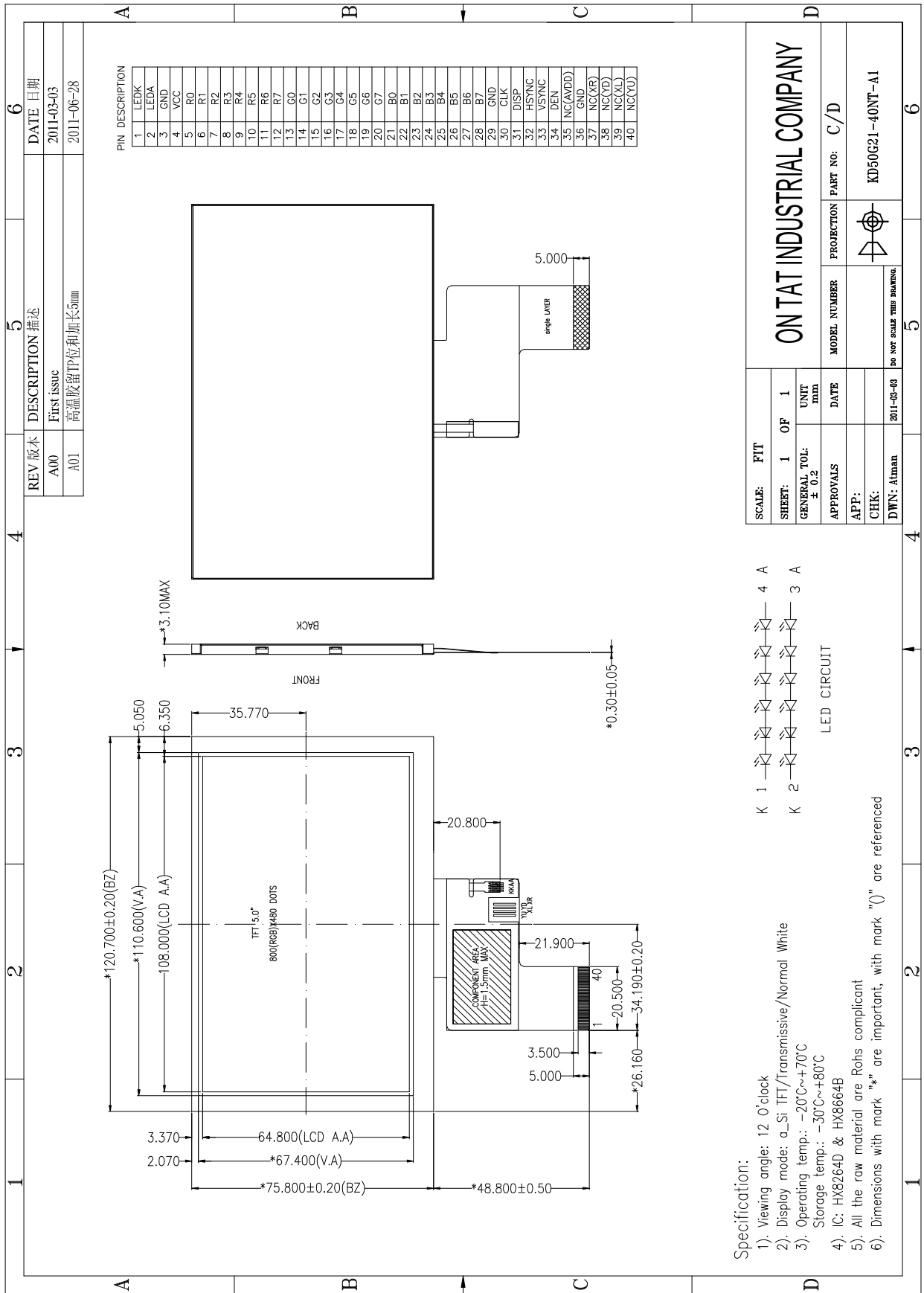

- Specification:
- 1). Viewing angle: 12 0'clock
 - 2). Display mode: a_Si TFT/Transmissive/Normal White
 - 3). Operating temp.: -20°C~+70°C
 - 4). IC: HX8264D & HX8664B
 - 5). All the raw material are Rohs compliant
 - 6). Dimensions with mark "*" are important, with mark "(") are referenced