

Switching Power Supply with Linear Regulators

The 33997 is a medium-power, multi-output power supply integrated circuit that is capable of operating over a wide input voltage range, from 6.0 V up to 26.5 V with 40 V transient capability. It incorporates a sensorless current mode control step-down switching controller regulating directly to 5.0 V. The 3.3 V linear regulator uses an external pass transistor to reduce the 33997 power dissipation. The 33997 also provides a 3.3 V linear standby regulator and two 5.0 V sensor supply outputs protected by internal low-resistance LDMOS transistors.

There are two separate enable pins for the main and sensor supply outputs and standard supervisory functions such as resets with power-up reset delay.

The 33997 provides proper power supply sequencing for advanced microprocessor architectures such as the Freescale MPC5xx and 683xx microprocessor families.

Features

- Operating Voltage Range 6.0 V up to 26.5 V (40 V transient)
- Step-Down Switching Regulator Output $V_{DDH} = 5.0 \text{ V}$ @ 1400 mA (total)
- Linear Regulator with External Pass Transistor $V_{DDL} = 3.3 \text{ V}$ @ 400 mA
- Low-Power Standby Linear Regulator $V_{KAM} = 3.3 \text{ V}$ @ 10 mA
- Two 5.0 V @ 200 mA (typical) Sensor Supplies V_{REF} Protected Against Short-to-Battery and Short-to-Ground with Retry Capability
- Undervoltage Shutdown on the V_{DDL} , V_{DDH} Outputs with Retry Capability
- Reset Signals
- Power-Up Delay
- Enable Pins for Main Supplies (EN) and Sensor Supplies (SNSEN)
- Power Sequencing for Advanced Microprocessor Architectures
- Pb-Free Packaging Designated by Suffix Code EG

33997

*
SWITCHING REGULATOR

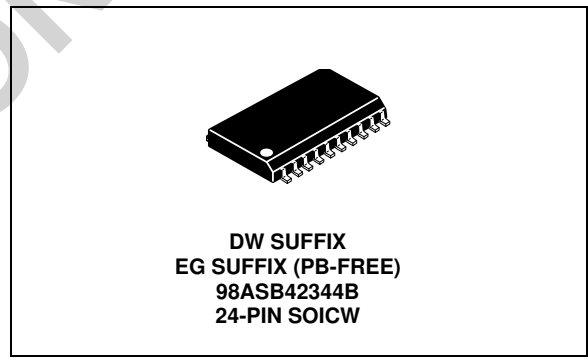

ORDERING INFORMATION		
Device	Temperature Range (T_A)	Package
MC33997DW/R2	-40°C to 125°C	24 SOICW
MC33997EG/R2		

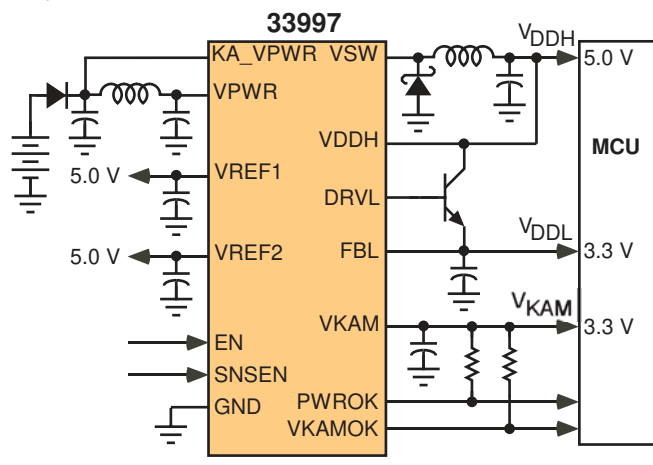

Figure 1. 33997 Simplified Application Diagram

* This document contains certain information on a new product. Specifications and information herein are subject to change without notice.
© Freescale Semiconductor, Inc., 2006. All rights reserved.



INTERNAL BLOCK DIAGRAM

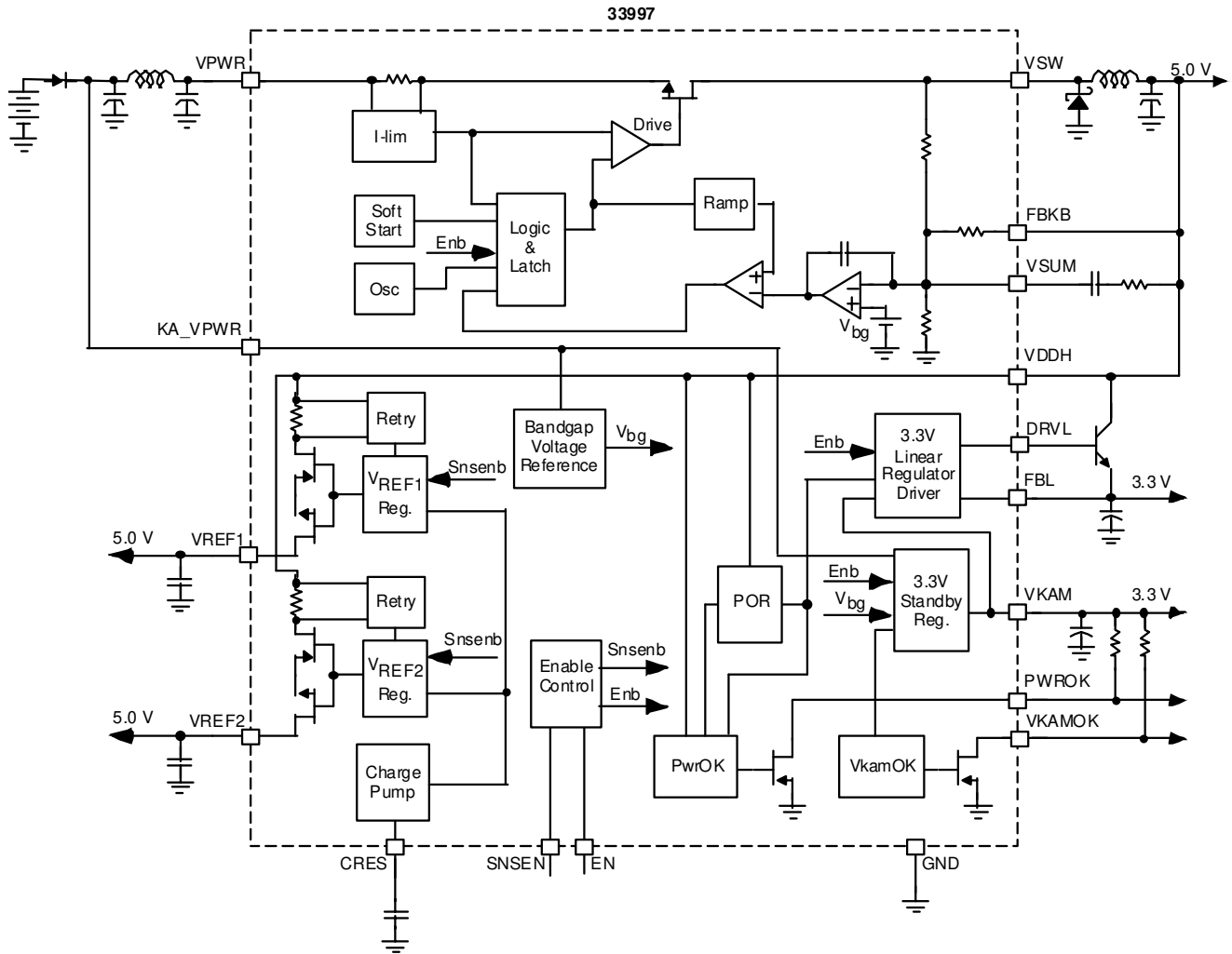

Figure 2. 33997 Simplified Internal Block Diagram

PIN CONNECTIONS

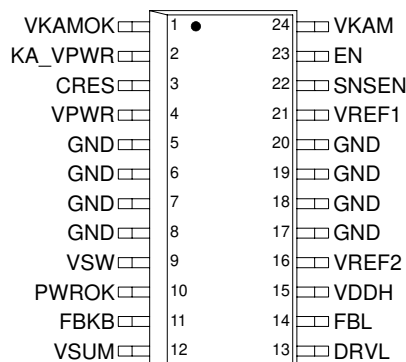

Figure 3. 33997 Pin Connections

Table 1. 33997 Pin Function Definition

Pin Number	Pin Name	Definition
1	VKAMOK	Keep-Alive Output Monitoring. This pin is an "open-drain" output that will be used with a discrete pull-up resistor to VKAM. When the supply voltage to the 33997 is disconnected or lost, the VKAMOK signal goes low.
2	KA_VPRW	Keep Alive Power Supply Pin. This supply pin is used in modules that have both direct battery connections and ignition switch activated connections.
3	CRES	Reservoir Capacitor. This pin is tied to an external "reservoir capacitor" for the internal charge pump.
4	VPWR	Power Supply Pin. Main power input to the IC. This pin is directly connected to the switching regulator power MOSFET. In automotive applications this pin must be protected against reverse battery conditions by an external diode.
5–8	GND	Ground of the integrated circuit.
9	VSW	Internal P-Channel Power MOSFET Drain. VSW is the "switching node" of the voltage buck converter. This pin is connected to the VPWR pin by an integrated p-channel MOSFET.
10	PWROK	Power OK Reset Pin. This pin is an "open-drain" output that will be used with a discrete pull-up resistor to V_{KAM} , V_{DDH} , or V_{DDL} . When either V_{DDH} or V_{DDL} output voltage goes out of the regulation limits this pin is pulled down.
11	FBKB	Step-Down Switching Regulator Feedback Pin. The FBKB pin is the V_{DDH} feedback signal for the switching regulator.
12	VSUM	Error Amplifier "Summing Node". The VSUM pin is connected to the inverting input of the error amplifier. This node is also the "common" point of the integrated feedback resistor divider.
13	DRVL	Drive for V_{DDL} (3.3 V) Regulator. The DRVL pin drives the base of an external NPN pass transistor for the V_{DDL} linear post regulator. The collector of the V_{DDL} pass transistor is connected to V_{DDH} . An example of a suitable pass transistor is BCP68.
14	FBL	Feedback for V_{DDL} (3.3 V) Regulator. The FBL pin is the voltage feedback sense signal from the V_{DDL} (3.3 V) linear post regulator.
15	VDDH	VDDH is an input supply pin providing power for the buffered sensor supplies and the drive circuitry for the 3.3 V linear power regulator. The VDDH pin is supplied from the switching regulator output, capable of providing 5.0 V @ 1400 mA total output current.
16	VREF2	Sensor Supply #2 Output. The VREF2 pin is sensor supply output #2.
17–20	GND	Ground of the integrated circuit.
21	VREF1	Sensor Supply #1 Output. The VREF1 pin is sensor supply output #1.
22	SNSEN	Sensor Supply Enable Input. The SNSEN pin is an input, which enables the V_{REF1} and V_{REF2} supplies. It allows the control module hardware/software to shut down the sensor supplies.

Table 1. 33997 Pin Function Definition (continued)

Pin Number	Pin Name	Definition
23	EN	Enable Input. The EN pin is an input, which enables the main switching regulator and all other functions. When this pin is low, the power supply is in a low quiescent state.
24	VKAM	Keep-Alive (standby) 3.3 V Regulator Output. This is a 3.3 V low quiescent, low dropout regulator for Keep Alive memory.

ELECTRICAL CHARACTERISTICS

MAXIMUM RATINGS

Table 2. Maximum Ratings

All voltages are with respect to ground unless otherwise noted. Exceeding these ratings may cause a malfunction or permanent damage to the device.

Ratings	Symbol	Value	Unit
Main Supply Voltage	V _{PWR}	-0.3 to 45	V
Keep-Alive Supply Voltage	KA_V _{PWR}	-0.3 to 45	V
Switching Node	V _{SW}	-0.5 to 45	V
5.0 V Input Power	V _{DDH}	-0.3 to 6.0	V
Sensor Supply	V _{REF1} V _{REF2}	-0.3 to 18 -0.3 to 18	V
Keep-Alive Supply Voltage	V _{KAM}	-0.3 to 6.0	V
Maximum Voltage at Logic I/O Pins	EN SNSEN PWROK VKAMOK	-0.3 to 6.0 -0.3 to 6.0 -0.3 to 6.0 -0.3 to 6.0	V
Charge Pump Reservoir Capacitor Voltage	C _{RES}	-0.3 to 18	V
Error Amplifier Summing Node	V _{SUM}	-0.3 to 6.0	V
Switching Regulator Output Feedback	FBKB	-0.3 to 6.0	V
VDDL Base Drive	DRVL	-0.3 to 6.0	V
VDDL Feedback	FBL	-0.3 to 6.0	V
ESD Voltage			V
Human Body Model (all pins) ⁽¹⁾	V _{ESD1}	±500	
Machine Model (all pins) ⁽¹⁾	V _{ESD2}	±100	
Power Dissipation (T _A = 25°C) ⁽²⁾	P _D	800	mW
Thermal Resistance, Junction to Ambient ^{(3), (4)}	R _{θJA}	60	°C/W
Thermal Resistance, Junction to Board ⁽⁵⁾	R _{θJB}	20	°C/W

Notes

- ESD1 testing is performed in accordance with the Human Body Model (C_{ZAP}=100 pF, R_{ZAP}=1500 Ω). ESD2 testing is performed in accordance with the Machine Model (C_{ZAP}=200 pF, R_{ZAP}=0 Ω)
- Maximum power dissipation at indicated junction temperature.
- Junction temperature is a function of on-chip power dissipation, package thermal resistance, mounting site (board) temperature, ambient temperature, air flow, power dissipation of other components on the board, and board thermal resistance.
- Per SEMI G38-87 and JEDEC JESD51-2 with the single layer board horizontal.
- Thermal resistance between the die and the printed circuit board per JEDEC JESD51-8. Board temperature is measured on the top surface of the board near the package.

Table 2. Maximum Ratings (continued)

All voltages are with respect to ground unless otherwise noted. Exceeding these ratings may cause a malfunction or permanent damage to the device.

Ratings	Symbol	Value	Unit
Operational Package Temperature [Ambient Temperature] ⁽⁶⁾	T _A	-40 to 125	°C
Operational Junction Temperature	T _J	-40 to 150	°C
Storage Temperature	T _{STG}	-55 to 150	°C
Lead Soldering Temperature ⁽⁷⁾	T _S	260	°C

Notes

6. The limiting factor is junction temperature, taking into account the power dissipation, thermal resistance, and heat sinking.
7. Lead soldering temperature limit is for 10 seconds maximum duration. Not designed for immersion soldering. Exceeding these limits may cause malfunction or permanent damage to the device.

STATIC ELECTRICAL CHARACTERISTICS

Table 3. Static Electrical Characteristics

Characteristics noted under conditions $9.0\text{ V} \leq V_{PWR} \leq 16\text{ V}$, $-40^\circ\text{C} \leq T_J = T_A \leq 125^\circ\text{C}$, using the typical application circuit (see [Figure](#)) unless otherwise noted. Typical values noted reflect the approximate parameter mean at $T_A = 25^\circ\text{C}$ under nominal conditions unless otherwise noted.

Characteristic	Symbol	Min	Typ	Max	Unit
GENERAL					
Supply Voltage Range					V
Normal Operating Voltage Range ⁽⁸⁾	$V_{PWR(N)}$	6.0	–	18	
Extended Operating Voltage Range ⁽⁸⁾	$V_{PWR(E)}$	18	–	26.5	
Maximum Transient Voltage - Load Dump ⁽⁹⁾	$V_{PWR(LD)}$	–	–	40	V
VPWR Supply Current	I_{VPWR}				mA
EN = 5.0 V, $V_{PWR} = 14\text{ V}$, No Loads		25	–	150	
VPWR Quiescent Supply Current	I_{Q_VPWR}				μA
EN = 0 V, $V_{PWR} = 12\text{ V}$		5.0	–	15	
KA_VPWR Supply Current,	I_{KAVPWR}				mA
EN = 5.0 V, $KA_V_{PWR} = 14\text{ V}$, No Load on V_{KAM}		0.5	–	3.0	
KA_VPWR Quiescent Supply Current	I_{Q_KAVPWR}				μA
EN = 0 V, $KA_V_{PWR} = 12\text{ V}$		50	–	350	
BUCK REGULATOR (VDDH)					
Buck Converter Output Voltage	V_{DDH}				V
$I_{VDDH} = 200\text{ mA}$ to 1.4 A, $V_{PWR} = KA_V_{PWR} = 14\text{ V}$		4.9	–	5.1	
Buck Converter Output Voltage	V_{DDH}				V
$I_{VDDH} = 1.4\text{ A}$, $V_{PWR} = KA_V_{PWR} = 6.0\text{ V}$		4.9	–	5.1	
VDDH Line Regulation	$REGLN_{VDDH}$				mV
$V_{PWR} = KA_V_{PWR} = 10\text{ V}$ to 14 V, $I_{VDDH} = 200\text{ mA}$		-20	–	30	
VDDH Load Regulation	$REGLD_{VDDH}$				mV
$V_{PWR} = KA_V_{PWR} = 14\text{ V}$, $I_{VDDH} = 200\text{ mA}$ to 1.4 A		-20	–	20	
$V_{PWR} = KA_V_{PWR} = 6.0\text{ V}$, $I_{VDDH} = 200\text{ mA}$ to 1.4 A		-20	–	20	
VDDH Active Discharge Resistance	R_{HDISCH}				Ω
$V_{PWR} = KA_V_{PWR} = 14\text{ V}$, EN = 0 V, $I_{VDDH} = 10\text{ mA}$		1.0	–	15	
P-CHANNEL MOSFET					
Drain-Source Breakdown Voltage—Not Tested ⁽¹⁰⁾	BV_{DSS}	45	–	–	V
Drain-Source Current Limit—Not Tested ⁽¹⁰⁾	ISC_{SW1}	–	-7.0	–	A

Notes

8. V_{DDH} is fully functional when the 33997 is operating at higher battery voltages, but these parameters are not tested. The test condition as are:
 - a) V_{DDH} must be between 4.9 V and 5.1 V (200 mA to 1.4 A) for $V_{PWR} = 14\text{ V}$ to 18 V.
 - b) V_{DDH} must be between 4.8 V and 5.5 V (200 mA to 1.4 A) for $V_{PWR} = 18\text{ V}$ to 26.5 V.
9. Part can survive, but no parameters are guaranteed.
10. Guaranteed by design but not production tested.

Table 3. Static Electrical Characteristics (continued)

Characteristics noted under conditions $9.0\text{ V} \leq V_{PWR} \leq 16\text{ V}$, $-40^\circ\text{C} \leq T_J = T_A \leq 125^\circ\text{C}$, using the typical application circuit (see [Figure](#)) unless otherwise noted. Typical values noted reflect the approximate parameter mean at $T_A = 25^\circ\text{C}$ under nominal conditions unless otherwise noted.

Characteristic	Symbol	Min	Typ	Max	Unit
LINEAR REGULATOR (VDDL)					
VDDL Output Voltage $V_{PWR} = KA_V_{PWR} = 14\text{ V}$, $I_{VDDL} = 200\text{ mA}$	V_{DDL}	3.15	–	3.45	V
VDDL Line Regulation $V_{DDH} = 4.8\text{ V}$ to 5.2 V , $I_{VDDL} = 400\text{ mA}$	$REGLN_{VDDL}$	-70	–	70	mV
VDDL Load Regulation $V_{PWR} = KA_V_{PWR} = 14\text{ V}$, $I_{VDDL} = 10\text{ mA}$ to 400 mA	$REGLD_{VDDL}$	-70	–	70	mV
DRVL Output Current $V_{PWR} = KA_V_{PWR} = 14\text{ V}$, $V_{DRVL} = 1.0\text{ V}$	I_{DRVL}	5.0	11	25	mA
VDDL Active Discharge Resistance $V_{PWR} = KA_V_{PWR} = 14\text{ V}$, $EN = 0\text{ V}$, $I_{FBL} = 10\text{ mA}$	R_{LDISCH}	1.0	–	10	Ω
VDDH to VDDL Active Clamp Resistance $V_{PWR} = KA_V_{PWR} = 14\text{ V}$, $EN = 0\text{ V}$, $I_{VDDH} = 50\text{ mA}$, $V_{FBKB} = 0\text{ V}$	R_{CLAMP}	0.6	–	10	Ω
VDDL Output Capacitor Capacitance ⁽¹¹⁾	C_{VDDL}	–	68	–	μF
VDDL Output Capacitor ESR ⁽¹¹⁾	ESR_{VDDL}	–	0.125	–	Ω
KEEP-ALIVE (STANDBY) REGULATOR (VKAM)					
VKAM Output Voltage $I_{VKAM} = 5.0\text{ mA}$, $V_{PWR} = KA_V_{PWR} = 18\text{ V}$, $EN = 5.0\text{ V}$	V_{KAM}	3.0	–	3.6	V
VKAM Output Voltage, $EN = 0\text{ V}$ (Standby Mode) $V_{PWR} = KA_V_{PWR} = 26\text{ V}$, $I_{VKAM} = 0.5\text{ mA}$ $V_{PWR} = KA_V_{PWR} = 18\text{ V}$, $I_{VKAM} = 5.0\text{ mA}$ $V_{PWR} = KA_V_{PWR} = 5.0\text{ V}$, $I_{VKAM} = 10.0\text{ mA}$ $V_{PWR} = 0\text{ V}$, $KA_V_{PWR} = 3.5\text{ V}$, $I_{VKAM} = 5.0\text{ mA}$	V_{KAM}	3.0 3.0 3.0 2.0	– – – –	3.6 3.6 3.6 3.5	V
VKAM Line Regulation, $EN = 0\text{ V}$ (Standby Mode) $V_{PWR} = KA_V_{PWR} = 5.0\text{ V}$ to 18 V , $I_{VKAM} = 2.0\text{ mA}$	$REGgLN_{VKAM}$	-20	–	20	mV
VKAM Load Regulation, $EN = 0\text{ V}$ (Standby Mode) $V_{PWR} = KA_V_{PWR} = 14\text{ V}$, $I_{VKAM} = 1.0\text{ mA}$ to 10 mA	$REGLD_{VKAM}$	0.0	–	100	mV
Differential Voltage $V_{KAM} - V_{DDL}$ $EN = 5.0\text{ V}$, $I_{VKAM} = 5.0\text{ mA}$, $V_{PWR} = KA_V_{PWR} = 14\text{ V}$, $I_{VDDL} = 200\text{ mA}$	REG_{VKAM}	-20	–	20	mV
VKAM Output Capacitor Capacitance ⁽¹¹⁾	C_{VKAM}	–	4.7	–	μF
VKAM Output Capacitor ESR ⁽¹¹⁾	ESR_{VKAM}	–	1.4	–	Ω

Notes

11. Recommended value.

Table 3. Static Electrical Characteristics (continued)

Characteristics noted under conditions $9.0\text{ V} \leq V_{PWR} \leq 16\text{ V}$, $-40^\circ\text{C} \leq T_J = T_A \leq 125^\circ\text{C}$, using the typical application circuit (see [Figure](#)) unless otherwise noted. Typical values noted reflect the approximate parameter mean at $T_A = 25^\circ\text{C}$ under nominal conditions unless otherwise noted.

Characteristic	Symbol	Min	Typ	Max	Unit
SENSOR SUPPLIES (VREF1, VREF2)					
VREF On-Resistance, $T_A = -40^\circ\text{C}$ $I_{VREF} = 200\text{ mA}$, $I_{VDDH} = 200\text{ mA}$, $V_{PWR} = KA_V_{PWR} = 14\text{ V}$, $EN = 5.0\text{ V}$	$R_{DS(ON)}$	–	–	280	$\text{m}\Omega$
VREF On-Resistance, $T_A = +25^\circ\text{C}$ $I_{VREF} = 200\text{ mA}$, $I_{VDDH} = 200\text{ mA}$, $V_{PWR} = KA_V_{PWR} = 14\text{ V}$, $EN = 5.0\text{ V}$	$R_{DS(ON)}$	–	–	350	$\text{m}\Omega$
VREF On-Resistance, $T_A = +125^\circ\text{C}$ $I_{VREF} = 200\text{ mA}$, $I_{VDDH} = 200\text{ mA}$, $V_{PWR} = KA_V_{PWR} = 14\text{ V}$, $EN = 5.0\text{ V}$	$R_{DS(ON)}$	–	–	455	$\text{m}\Omega$
VREF Short-to-Battery Detect Current $V_{PWR} = KA_V_{PWR} = 14\text{ V}$, $EN = 5.0\text{ V}$, $SNSEN = 5.0\text{ V}$	I_{SC_BAT}	500	–	900	mA
VREF Short-to-Ground Detect Current $V_{PWR} = KA_V_{PWR} = 14\text{ V}$, $EN = 5.0\text{ V}$, $SNSEN = 5.0\text{ V}$	I_{SC_GND}	500	–	900	mA
Maximum Output Capacitance (Total) ⁽¹²⁾	C_{VREF}	33	–	39	nF
SUPERVISORY CIRCUITS (VPWR)					
PWROK Undervoltage Threshold on V_{DDL} , FBL Ramps Down $V_{PWR} = KA_V_{PWR} = 14\text{ V}$, $I_{VDDH} = 200\text{ mA}$	$V_{FBL(THL)}$	2.6	–	3.1	V
PWROK Undervoltage Threshold on V_{DDH} $V_{PWR} = KA_V_{PWR} = 14\text{ V}$, $I_{VDDH} = 200\text{ mA}$	$V_{DDH(THL)}$	4.5	–	4.8	V
VDDH Overvoltage Threshold $V_{PWR} = KA_V_{PWR} = 10\text{ V}$, $I_{VDDH} = 200\text{ mA}$	$V_{DDH(THH)}$	5.12	–	5.7	V
PWROK Open Drain On-Resistance $V_{PWR} = KA_V_{PWR} = 14\text{ V}$, $EN = 5\text{ V}$, $I_{PwrOK} = 5.0\text{ mA}$	$R_{DS(ON)}$	–	–	200	Ω
VKAMOK Threshold, $V_{PWR} = KA_V_{PWR} = 14\text{ V}$, $I_{VDDH} = 200\text{ mA}$	$V_{KAM(THL)}$	0.9	–	1.9	V
VKAMOK Threshold on V_{PWR} , V_{PWR} Ramps Up $KA_V_{PWR} = 14\text{ V}$, $I_{VDDH} = 200\text{ mA}$	$V_{PWRok(TH)}$	4.0	–	5.0	V
VKAMOK Open Drain On-Resistance $V_{PWR} = KA_V_{PWR} = 14\text{ V}$, $EN = 0\text{ V}$, $I_{VKAMOK} = 10\text{ mA}$	$R_{DS(ON)}$	50	–	200	Ω
Enable Input Voltage Threshold (Pin EN)	V_{IH}	1.0	–	2.0	V
Enable Pull-Down Current (Pin EN), $EN = 1.0\text{ V}$ V_{DDH} to $V_{IL(min)}$	I_{PD}	500	–	1200	nA
Sensor Enable Input Voltage Threshold (Pin SNSEN)	V_{IH}	1.0	–	2.0	V
Sensor Enable Pull-Down Current (Pin SNSEN) $SNSEN = 1.0\text{ V}$ V_{DDH} to $V_{IL(min)}$	I_{PD}	500	–	1200	nA

Notes

12. Recommended value.

Table 3. Static Electrical Characteristics (continued)

Characteristics noted under conditions $9.0\text{ V} \leq V_{PWR} \leq 16\text{ V}$, $-40^\circ\text{C} \leq T_J = T_A \leq 125^\circ\text{C}$, using the typical application circuit (see [Figure](#)) unless otherwise noted. Typical values noted reflect the approximate parameter mean at $T_A = 25^\circ\text{C}$ under nominal conditions unless otherwise noted.

Characteristic	Symbol	Min	Typ	Max	Unit
CHARGE PUMP (CRES)					
Charge Pump Voltage	V_{CRES}				V
$V_{PWR} = KA_V_{PWR} = 14\text{ V}$, $I_{VDDH} = 200\text{ mA}$, $I_{CP} = 0\text{ }\mu\text{A}$		12	–	15	
$V_{PWR} = KA_V_{PWR} = 14\text{ V}$, $I_{VDDH} = 200\text{ mA}$, $I_{CP} = 10\text{ }\mu\text{A}$		12	–	15	

DYNAMIC ELECTRICAL CHARACTERISTICS**Table 4. Dynamic Electrical Characteristics**

Characteristics noted under conditions $9.0\text{ V} \leq V_{\text{PWR}} \leq 16\text{ V}$, $-40^\circ\text{C} \leq T_{\text{J}} = T_{\text{A}} \leq 125^\circ\text{C}$ using the typical application circuit (see [Figure](#)) unless otherwise noted. Typical values noted reflect the approximate parameter mean at $T_{\text{A}} = 25^\circ\text{C}$ under nominal conditions unless otherwise noted.

Characteristic	Symbol	Min	Typ	Max	Unit
BUCK REGULATOR (VDDH)					
Switching Frequency ⁽¹³⁾	f_{SW}	–	750	–	kHz
Soft Start Duration (see Figure 4) $V_{\text{PWR}} = \text{KA_}V_{\text{PWR}} = 6.0\text{ V}$	t_{SS}	5.0	–	15	ms
CHARGE PUMP (CRES)					
Charge Pump Current Ramp-Up Time $V_{\text{PWR}} = \text{KA_}V_{\text{PWR}} = 14\text{ V}$, $C_{\text{RES}} = 22\text{ nF}$, $V_{\text{CP}} = 1.0\text{ V to }11\text{ V}$	t_{CRES}	1.0	–	20	ms
Charge Pump Ramp-Up Time $V_{\text{PWR}} = \text{KA_}V_{\text{PWR}} = 7.0\text{ V}$, $C_{\text{RES}} = 22\text{ nF}$, $V_{\text{CP}} = 7.0\text{ V to }10\text{ V}$	t_{CRES}	1.0	–	10	ms
SENSOR SUPPLIES (VREF1, VREF2)					
V_{REF} Overcurrent Detection Time (see Figure 7) V_{REF} Load $R_{\text{L}} = 5.0\ \Omega$ to GND, $V_{\text{DDH}} = 5.1\text{ V}$, $V_{\text{PWR}} = \text{KA_}V_{\text{PWR}} = 10\text{ V}$, $\text{EN} = 5.0\text{ V}$, $\text{SNSEN} = 5.0\text{ V}$	t_{DET}	0.5	–	2.0	μs
V_{REF} Retry Timer Delay (see Figure 7) V_{REF} Load $R_{\text{L}} = 5.0\ \Omega$ to GND, $V_{\text{DDH}} = 5.1\text{ V}$, $V_{\text{PWR}} = \text{KA_}V_{\text{PWR}} = 10\text{ V}$, $\text{EN} = 5.0\text{ V}$, $\text{SNSEN} = 5.0\text{ V}$	t_{RET}	5.0	–	20	ms
SUPERVISORY CIRCUITS (VPWR)					
PWROK Delay Time (Power-On Reset) (see Figure 6)	$t_{\text{D(PWROK)}}$	5.0	–	15	ms
VKAMOK Delay Time (see Figure 7)	$t_{\text{D(VKAMOK)}}$	10	–	30	ms
VDDH Power-Up Delay Time (see Figure 8)	$t_{\text{D(VPWR)}}$	1.0	–	10	ms
Fault-Off Timer Delay Time (see Figure 9)	t_{FAIL}	1.0	–	10	ms

Notes

13. Guaranteed by design but not production tested.

TIMING DIAGRAMS

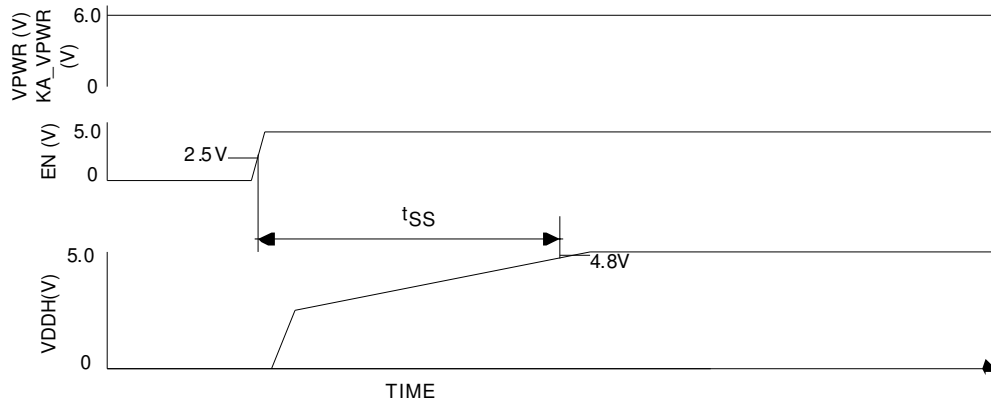

Figure 4. Soft-Start Time

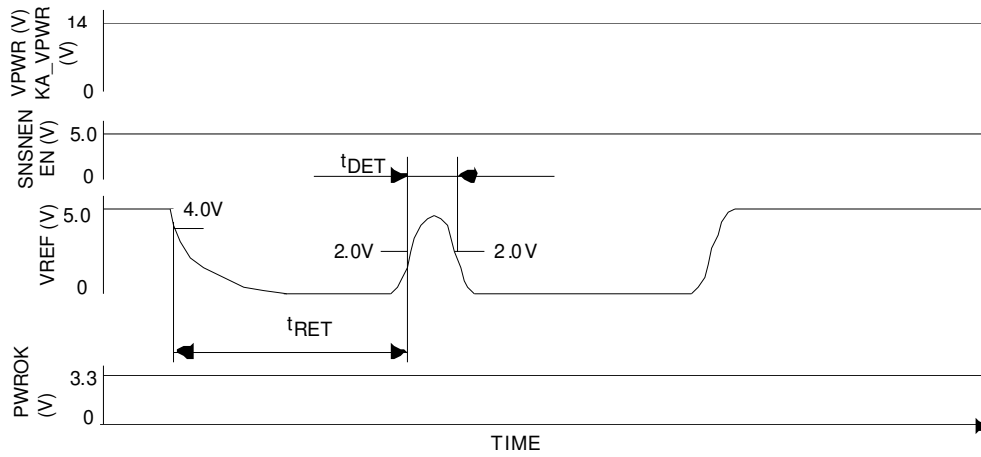

Figure 5. VREF Retry Timer

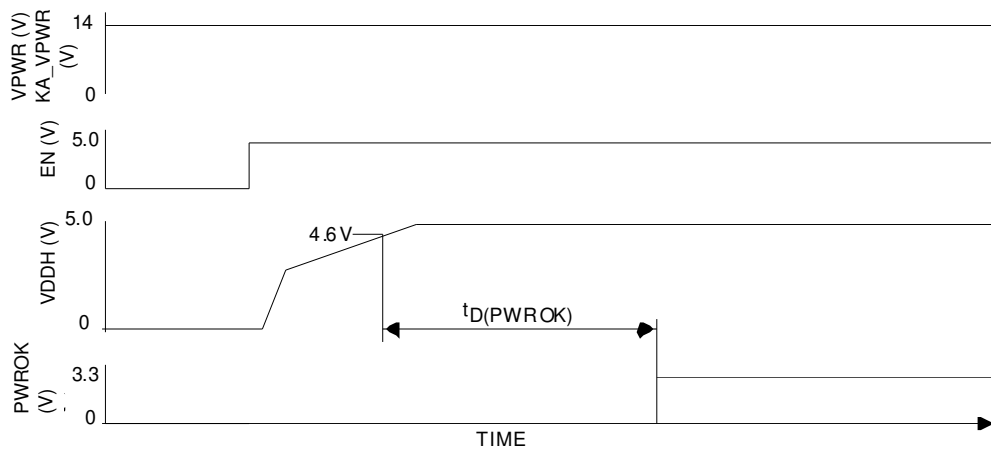
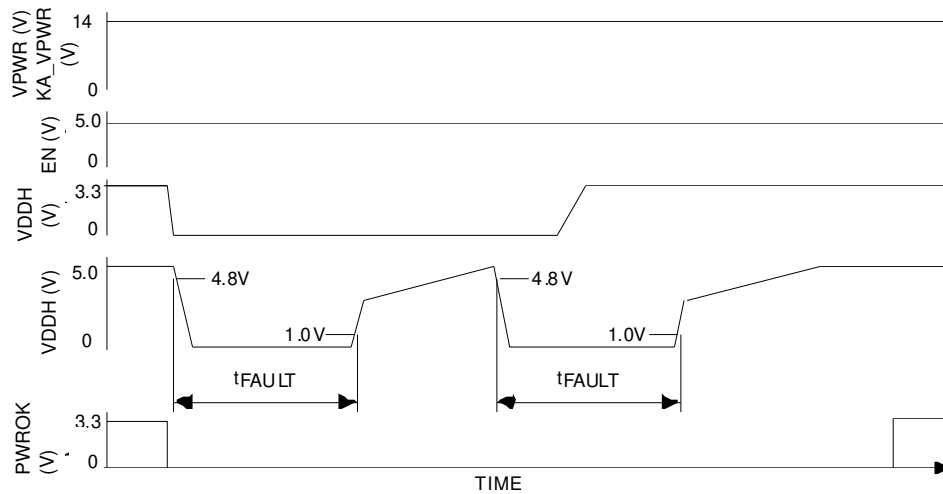
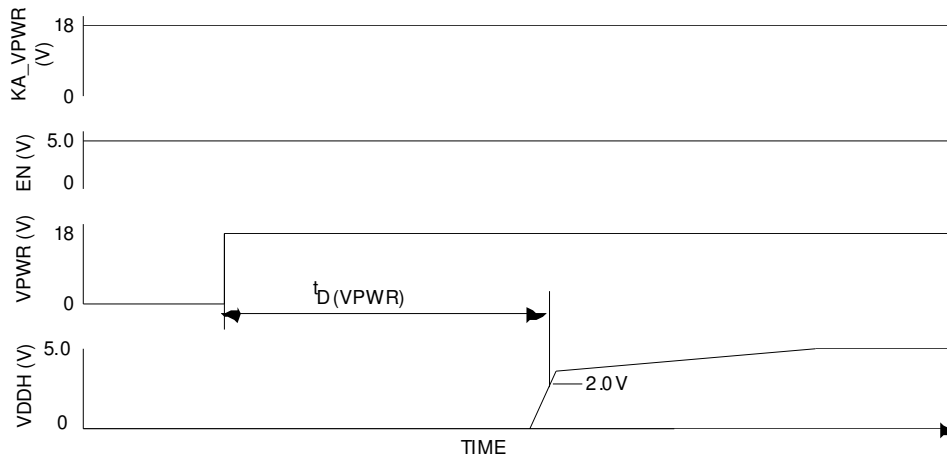
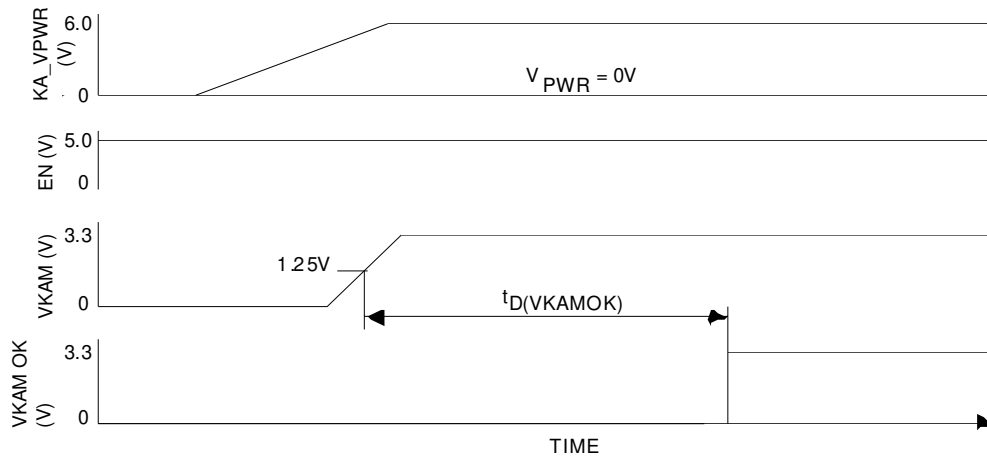

Figure 6. PWROK Delay Timer (Power-On Reset)



FUNCTIONAL DESCRIPTION

INTRODUCTION

The 33997 multi-output power supply integrated circuit is capable of operating from 6.0 V up to 26.5 V with 40 V transient capability. It incorporates a step-down switching controller regulating directly to 5.0 V. The 3.3 V linear regulator uses an external pass transistor, thus reducing the

power dissipation of the integrated circuit. The 33997 also provides a 3.3 V linear standby regulator and two 5.0 V sensor supply outputs protected by internal low-resistance LDMOS transistors against short-to-battery and short-to-ground.

FUNCTIONAL PIN DESCRIPTION

SWITCHING REGULATOR (VDDH)

The switching regulator is a high-frequency (750 kHz), conventional buck converter with integrated high-side p-channel power MOSFET. Its output voltage is regulated to provide 5.0 V with $\pm 2\%$ accuracy and it is intended to directly power the digital and analog circuits of the Electronic Control Module (ECM). The switching regulator output is rated for 1400 mA total output current. This current can be used by the linear regulator VDDL and sensor supplies VREF1 and VREF2. The 33997 switching controller utilizes "Sensorless Current Mode Control" to achieve good line rejection and stabilize the feedback loop. A soft-start feature is incorporated into the 33997. When the device is enabled, the switching regulator output voltage VDDH ramps up to about half of full scale and then takes 16 steps up to the nominal regulation voltage level (5.0 V nominal).

3.3 V LINEAR REGULATOR (VDDL)

The 3.3 V linear post-regulator is powered from the 5.0 V switching regulator output (VDDH). A discrete pass transistor is used to the power path for the VDDL regulator. This arrangement minimizes the power dissipation off the controller IC. The FBL pin is the feedback input of the regulator control loop and the DRVL pin the external NPN pass transistor base drive. Power up, power down, and fault management are coordinated with the 5.0 V switching regulator.

SENSOR SUPPLIES (VREF1) AND (VREF2)

The sensor supplies are implemented using a protected switch to the main 5.0 V (switching regulator) output. The 33997 integrated circuit provides two low-resistance LDMOS power MOSFETs connected to the switching regulator output (VDDH). These switches have short-to-battery and short-to-ground protection integrated into the IC. When a severe fault conditions is detected, the affected sensor output is turned off and the sensor Retry Timer starts to time out. After the Retry Timer expires, the sensor supply tries to power up again. Sensor supplies VREF can be disabled by pulling the Sensor Enable SENSE pin low (see [Figure 9](#) for the V_{REF} Retry Timer operation).

Notes: Severe fault conditions on the VREF1 and VREF2 outputs, like hard shorts to either ground or battery, may disrupt the operation of the main regulator V_{DDH} . Shorts to

battery above 17 V are considered "double faults" and neither one of the VREF outputs is protected against such conditions.

Depending on the VDDH capacitor value and its ESR value, the severity of the short may disrupt the VDDH operation.

KEEP-ALIVE REGULATOR, STANDBY (VKAM)

The Keep-Alive Regulator VKAM (keep-alive memory) is intended to provide power for "key off" functions such as nonvolatile SRAM, "KeyOff" timers and controls, KeySwitch monitor circuits, and perhaps a CAN/SCP monitor and wake-up function. It may also power other low-current circuits required during a "KeyOff" condition. The regulated voltage is nominally 3.3 V. A severe fault condition on the VKAM output is signaled by pulling the VKAMOK signal low.

KEEP-ALIVE OPERATION STANDBY, POWER-DOWN MODE (VKAM)

When the EN pin is pulled low, the power supply is forced into a low-current standby mode. In order to reduce current drawn by the VPWR and KA_VPWR pins, all power supply functions are disabled except for the VKAM and Enable (EN) pins. The latter pin is monitored for the "wake-up" signal. The switching transistor gate is actively disabled and the VDDL and VDDH pins are actively pulled low.

POWER-UP DELAY TIMERS

Two Power-Up Delay timers are integrated into the control section of the integrated circuit. One timer monitors the input voltage at the VPWR input pin (see [Figure 5](#)), and the other monitors the input voltage at the KA_VPWR input pin. In both cases, sufficient supply voltage must be present long enough for the timers to "time out" before the switching regulator can be enabled.

FAULT-OFF TIMER

If the VDDL output voltage does not reach its valid range at the end of soft-start period, or if the VDDH or VDDL output voltage gets below its PWROK threshold level, the Fault-Off Timer shuts the switching regulator off until the timer "times out" and the switching regulator retries to power up again (see [Figure 9](#) for Fault-Off Timer operation details).

POWER-ON RESET TIMER

This timer starts to time out at the end of the soft-start period if the VDDH and VDDL outputs are in the valid regulation range. If the timer "times out", then the open-drain PWROK signal is released, indicating that "power is ON".

SUPERVISORY CIRCUITS (PWROK) AND (VKAMOK)

The 33997 has two voltage monitoring open-drain outputs, the PWROK and the VKAMOK pins. PWROK is "active high". This output is pulled low when either of the regulator outputs

(VDDH or VDDL) are below their regulation windows. If both regulator outputs are above their respective lower thresholds, and the Power-On Reset Timer has expired, the output driver is turned off and this pin is at high-impedance state (see [Figure 8](#)).

The VKAMOK signal indicates a severe fault condition on the keep-alive regulator output VKAM. The VKAM output voltage is compared to the internal bandgap reference voltage. When the V_{KAM} falls below the bandgap reference voltage level, the VKAMOK signal is pulled low.

TYPICAL APPLICATIONS

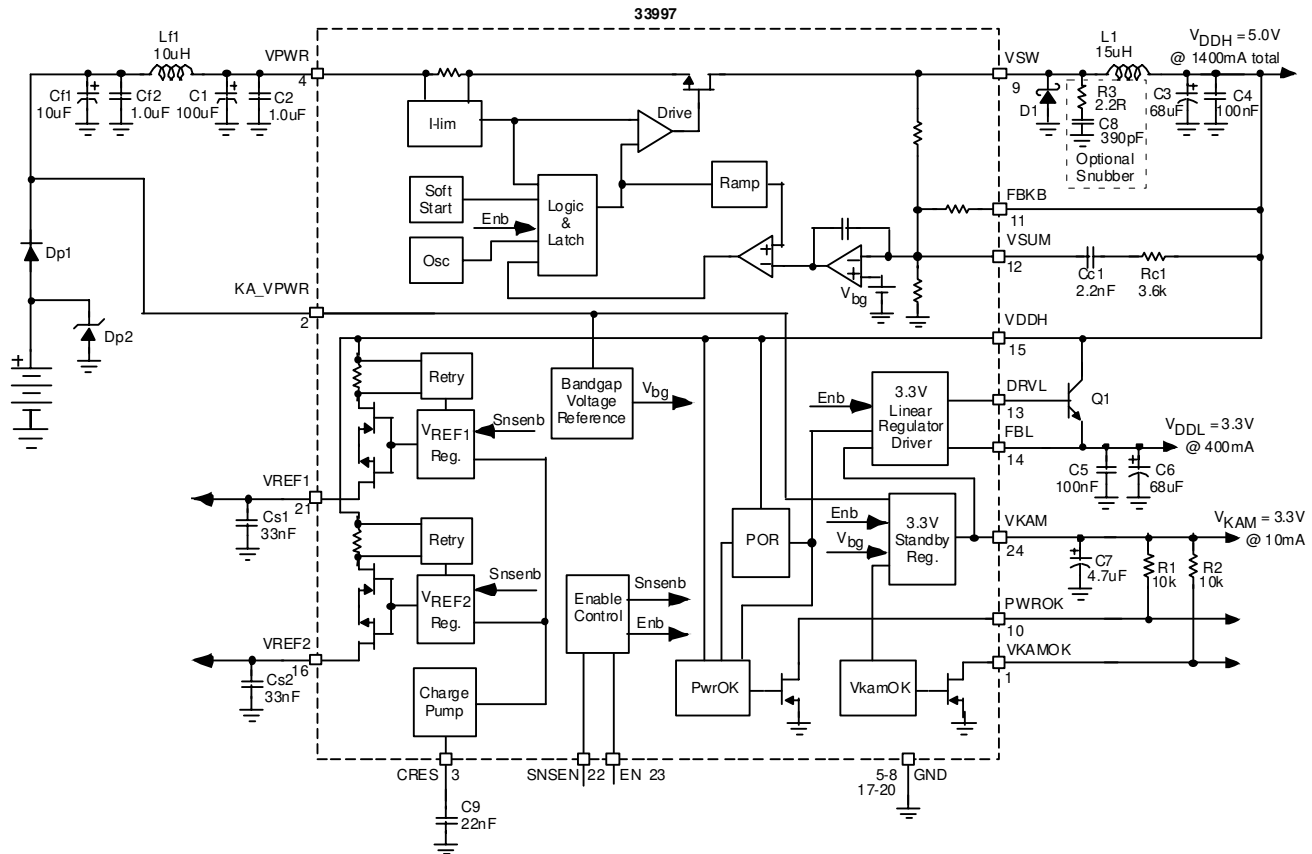

Note The VDDH total output current is 1.4 A. This includes the current used by the linear regulator VDDL and buffered outputs VREF1 and VREF2.

Figure 10. 33997 Application Circuit Schematic Diagram

Table 5. Recommended Components

Designator	Value/Rating	Description/Part No.	Manufacturer ⁽¹⁵⁾
Cf1	10 μ F/50 V	Aluminum Electrolytic/UUB1H100MNR	Nichicon
Cf2, C2	1.0 μ F/50 V	Ceramic X7R/C1812C105K5RACTR	Kemet
C1	100 μ F/50 V	Aluminum Electrolytic/UUH1V101MNR	Nichicon
C3 ⁽¹⁴⁾	68 μ F/10 V	Tantalum/T494D686M010AS	Kemet
C6	68 μ F/10 V	Tantalum/T494D686M010AS	Kemet
C7	4.7 μ F/10 V	Tantalum/T494A475M010AS	Kemet
C4, C5	100 nF/16 V	Ceramic X7R	Any Manufacturer
C8 (Optional)	390 pF/50 V	Ceramic X7R	Any Manufacturer

Notes

- It is possible to use ceramic capacitors in the switcher output, e.g. C3 = 2 x 22 μ F/6.3 V X7R ceramic. In this case the compensation resistor has to be changed to Rc1 = 200 Ω to stabilize the switching regulator operation.
- Freescale does not assume liability, endorse, or warrant components from external manufacturers that are referenced in circuit drawings or tables. While Freescale offers component recommendations in this configuration, it is the customer's responsibility to validate their application.

Table 5. Recommended Components (continued)

Designator	Value/Rating	Description/Part No.	Manufacturer ⁽¹⁵⁾
C9	22 nF/25 V	Ceramic X7R	Any Manufacturer
Cs1, Cs2	33 nF/25 V	Ceramic X7R	Any Manufacturer
Cc1	2.2 nF/16 V	Ceramic X7R	Any Manufacturer
R1, R2	10 k Ω	Resistor 0805, 5%	Any Manufacturer
R3 (Optional)	2.2 Ω	Resistor 0805, 5%	Any Manufacturer
Rc1	3.6 k Ω	Resistor 0805, 5%	Any Manufacturer
Lf1	10 μ H	CDRH127-100M or SLF10145-100M2R5	Sumida TDK
L1	15 μ H	CDRH127-150MC or SLF10145-150M2R2	Sumida TDK
Q1	1.0 A/20 V	Bipolar Transistor/BCP68T1	ON Semiconductor
D1	2.0 A/50 V	Schottky Diode/SS25	General Semiconductor
Dp1	3.0 A/200 V	Diode/MURS320	ON Semiconductor
Dp2	27 V	Transient Voltage Suppressor/SM5A27	General Semiconductor

Notes

16. Freescale does not assume liability, endorse, or warrant components from external manufacturers that are referenced in circuit drawings or tables. While Freescale offers component recommendations in this configuration, it is the customer's responsibility to validate their application.

PACKAGING

PACKAGE DIMENSIONS

For the most current revision of the package, visit www.freescale.com and perform a keyword search using the “98A” drawing number listed below.

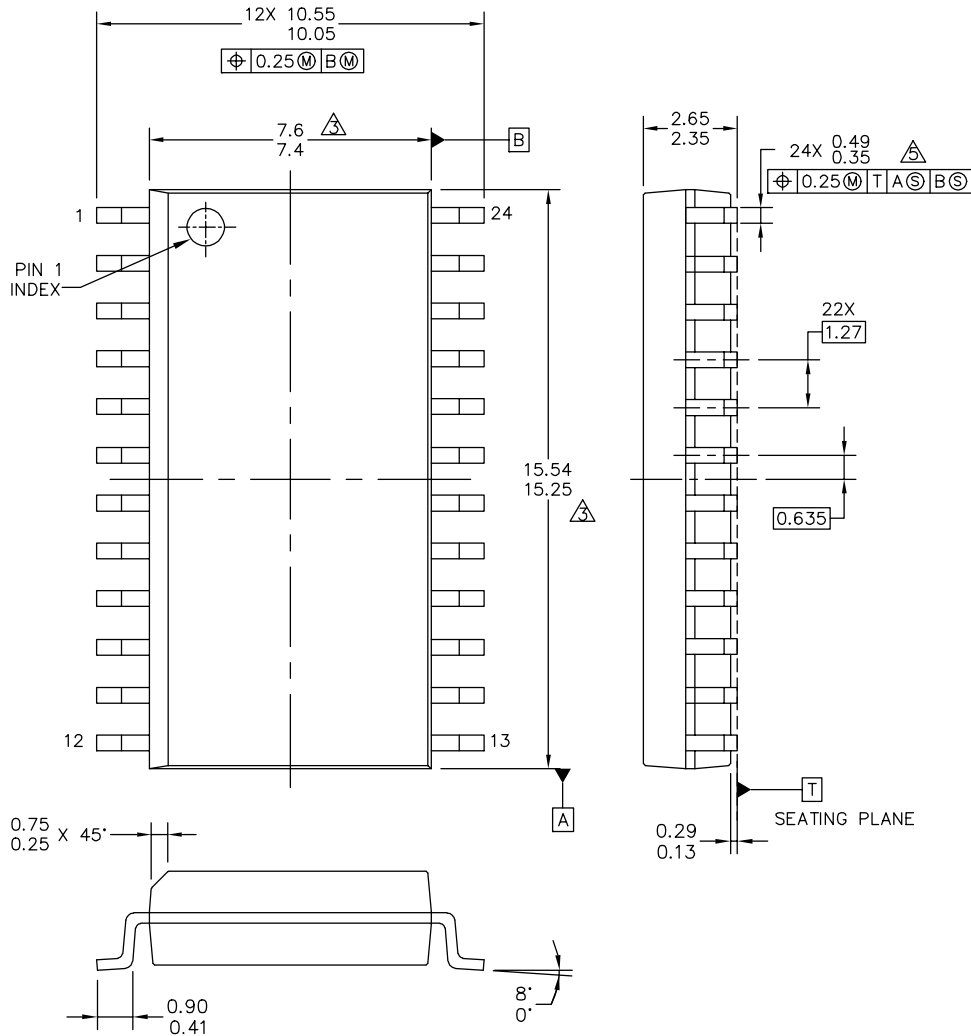

© FREESCALE SEMICONDUCTOR, INC. ALL RIGHTS RESERVED.	MECHANICAL OUTLINE	PRINT VERSION NOT TO SCALE	
TITLE: 24LD SOIC W/B, 1.27 PITCH 7.5 X 15.4 CASE-OUTLINE	DOCUMENT NO: 98ASB42344B	REV: F	
	CASE NUMBER: 751E-04	26 APR 2005	
	STANDARD: JEDEC MS-013 AD		

DWB SUFFIX
EG SUPPFFIX (PB-FREE)
24 PIN SOIC WIDE BODY
PLASTIC PACKAGE
98ASB42344B
ISSUE F

REVISION HISTORY

REVISION	DATE	DESCRIPTION OF CHANGES
4.0	6/2006	<ul style="list-style-type: none">• Converted to Freescale format• Update to the prevailing Freescale form and style.

How to Reach Us:

Home Page:

www.freescale.com

E-mail:

support@freescale.com

USA/Europe or Locations Not Listed:

Freescale Semiconductor
Technical Information Center, CH370
1300 N. Alma School Road
Chandler, Arizona 85224
+1-800-521-6274 or +1-480-768-2130
support@freescale.com

Europe, Middle East, and Africa:

Freescale Halbleiter Deutschland GmbH
Technical Information Center
Schatzbogen 7
81829 Muenchen, Germany
+44 1296 380 456 (English)
+46 8 52200080 (English)
+49 89 92103 559 (German)
+33 1 69 35 48 48 (French)
support@freescale.com

Japan:

Freescale Semiconductor Japan Ltd.
Headquarters
ARCO Tower 15F
1-8-1, Shimo-Meguro, Meguro-ku,
Tokyo 153-0064
Japan
0120 191014 or +81 3 5437 9125
support.japan@freescale.com

Asia/Pacific:

Freescale Semiconductor Hong Kong Ltd.
Technical Information Center
2 Dai King Street
Tai Po Industrial Estate
Tai Po, N.T., Hong Kong
+800 2666 8080
support.asia@freescale.com

For Literature Requests Only:

Freescale Semiconductor Literature Distribution Center
P.O. Box 5405
Denver, Colorado 80217
1-800-441-2447 or 303-675-2140
Fax: 303-675-2150
LDCForFreescaleSemiconductor@hibbertgroup.com

RoHS-compliant and/or Pb-free versions of Freescale products have the functionality and electrical characteristics of their non-RoHS-compliant and/or non-Pb-free counterparts. For further information, see <http://www.freescale.com> or contact your Freescale sales representative.

For information on Freescale's Environmental Products program, go to <http://www.freescale.com/epp>.

Information in this document is provided solely to enable system and software implementers to use Freescale Semiconductor products. There are no express or implied copyright licenses granted hereunder to design or fabricate any integrated circuits or integrated circuits based on the information in this document.

Freescale Semiconductor reserves the right to make changes without further notice to any products herein. Freescale Semiconductor makes no warranty, representation or guarantee regarding the suitability of its products for any particular purpose, nor does Freescale Semiconductor assume any liability arising out of the application or use of any product or circuit, and specifically disclaims any and all liability, including without limitation consequential or incidental damages. "Typical" parameters that may be provided in Freescale Semiconductor data sheets and/or specifications can and do vary in different applications and actual performance may vary over time. All operating parameters, including "Typicals", must be validated for each customer application by customer's technical experts. Freescale Semiconductor does not convey any license under its patent rights nor the rights of others. Freescale Semiconductor products are not designed, intended, or authorized for use as components in systems intended for surgical implant into the body, or other applications intended to support or sustain life, or for any other application in which the failure of the Freescale Semiconductor product could create a situation where personal injury or death may occur. Should Buyer purchase or use Freescale Semiconductor products for any such unintended or unauthorized application, Buyer shall indemnify and hold Freescale Semiconductor and its officers, employees, subsidiaries, affiliates, and distributors harmless against all claims, costs, damages, and expenses, and reasonable attorney fees arising out of, directly or indirectly, any claim of personal injury or death associated with such unintended or unauthorized use, even if such claim alleges that Freescale Semiconductor was negligent regarding the design or manufacture of the part.

Freescale™ and the Freescale logo are trademarks of Freescale Semiconductor, Inc. All other product or service names are the property of their respective owners.

© Freescale Semiconductor, Inc., 2006. All rights reserved.