

THIS DRAWING IS UNPUBLISHED. RELEASED FOR PUBLICATION 20  
 © COPYRIGHT 20 BY - ALL RIGHTS RESERVED.

REVISIONS				
P	LTR	DESCRIPTION	DATE	APVD
A		INITIAL RELEASE	14SEP2021	

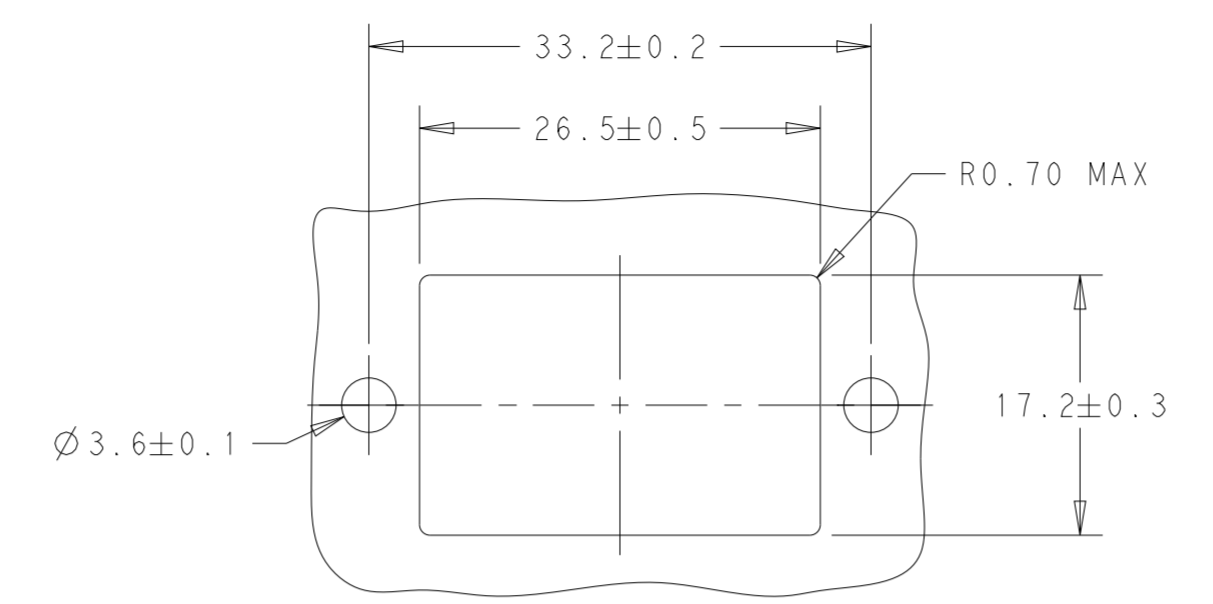

RECOMMENDED PANEL LAYOUT  
 (2332801-5 THRU 2332801-8)

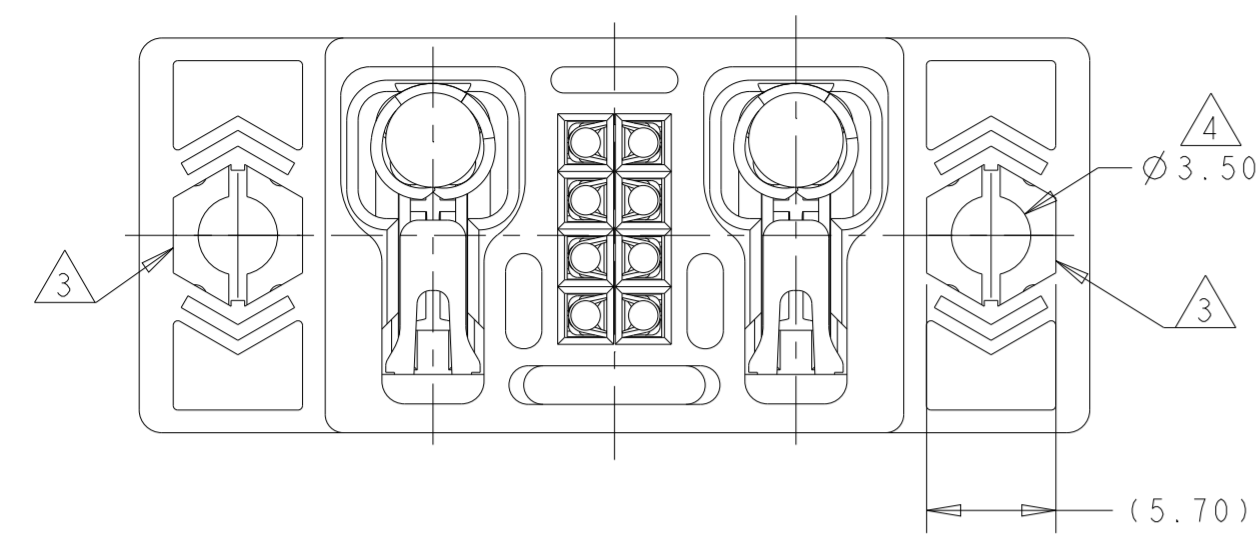
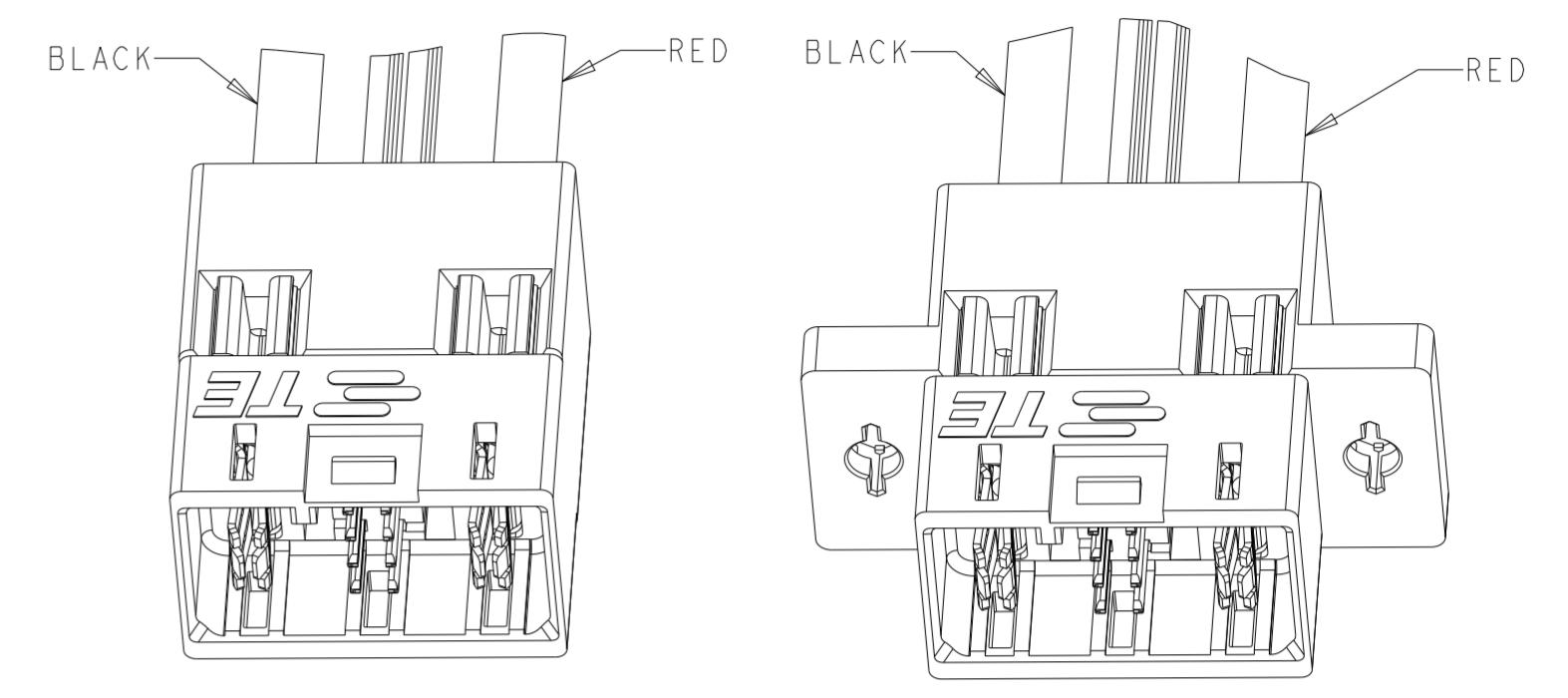

SCALE 2:1  
 2332801-1 THRU  
 2332801-4

SCALE 2:1  
 PANEL MOUNT  
 2332801-5 THRU  
 2332801-8

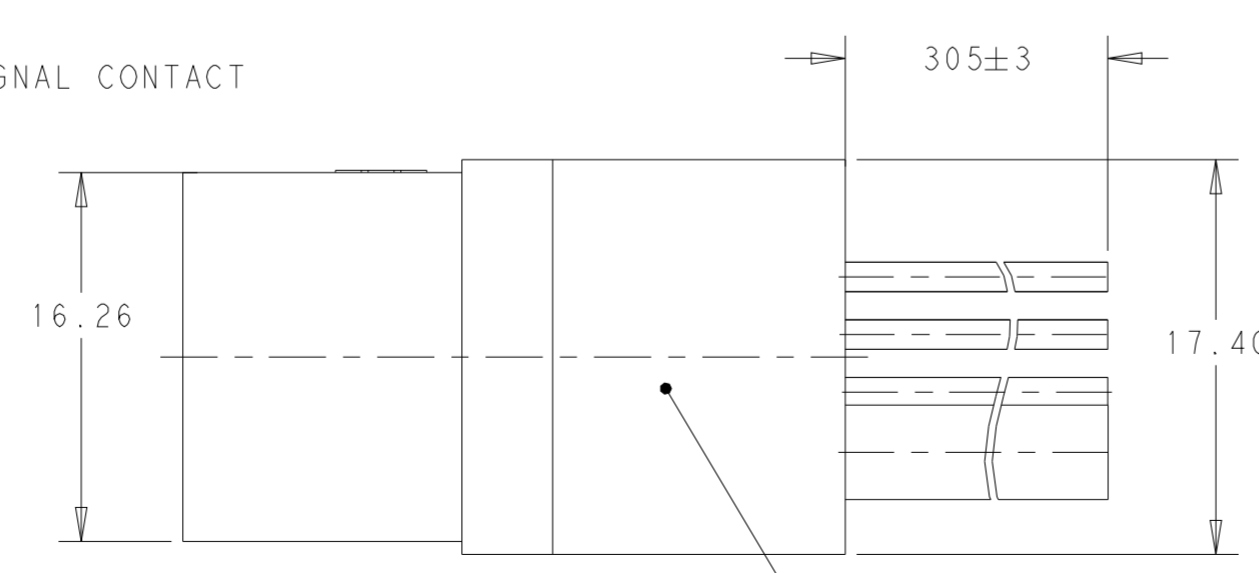
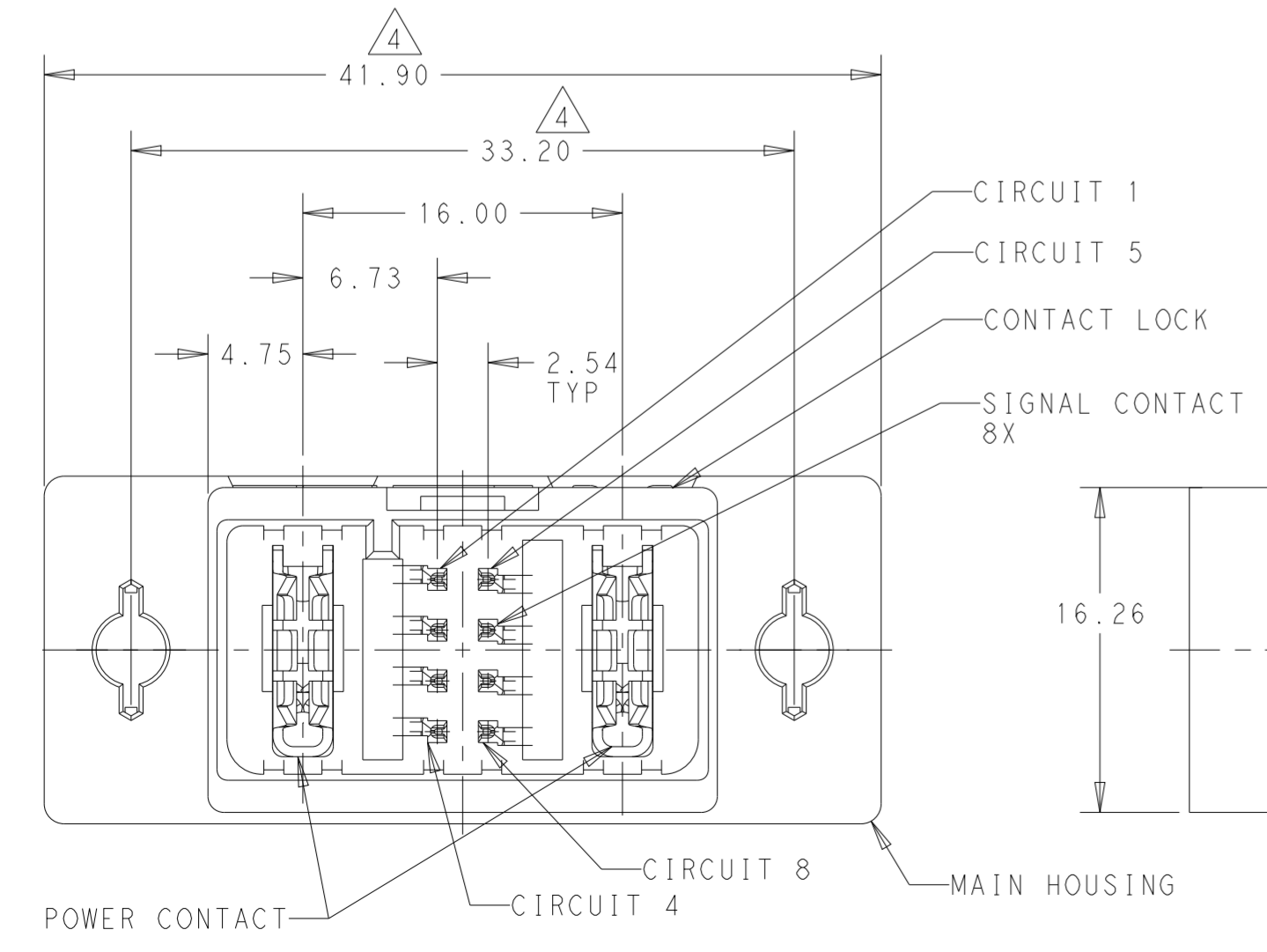
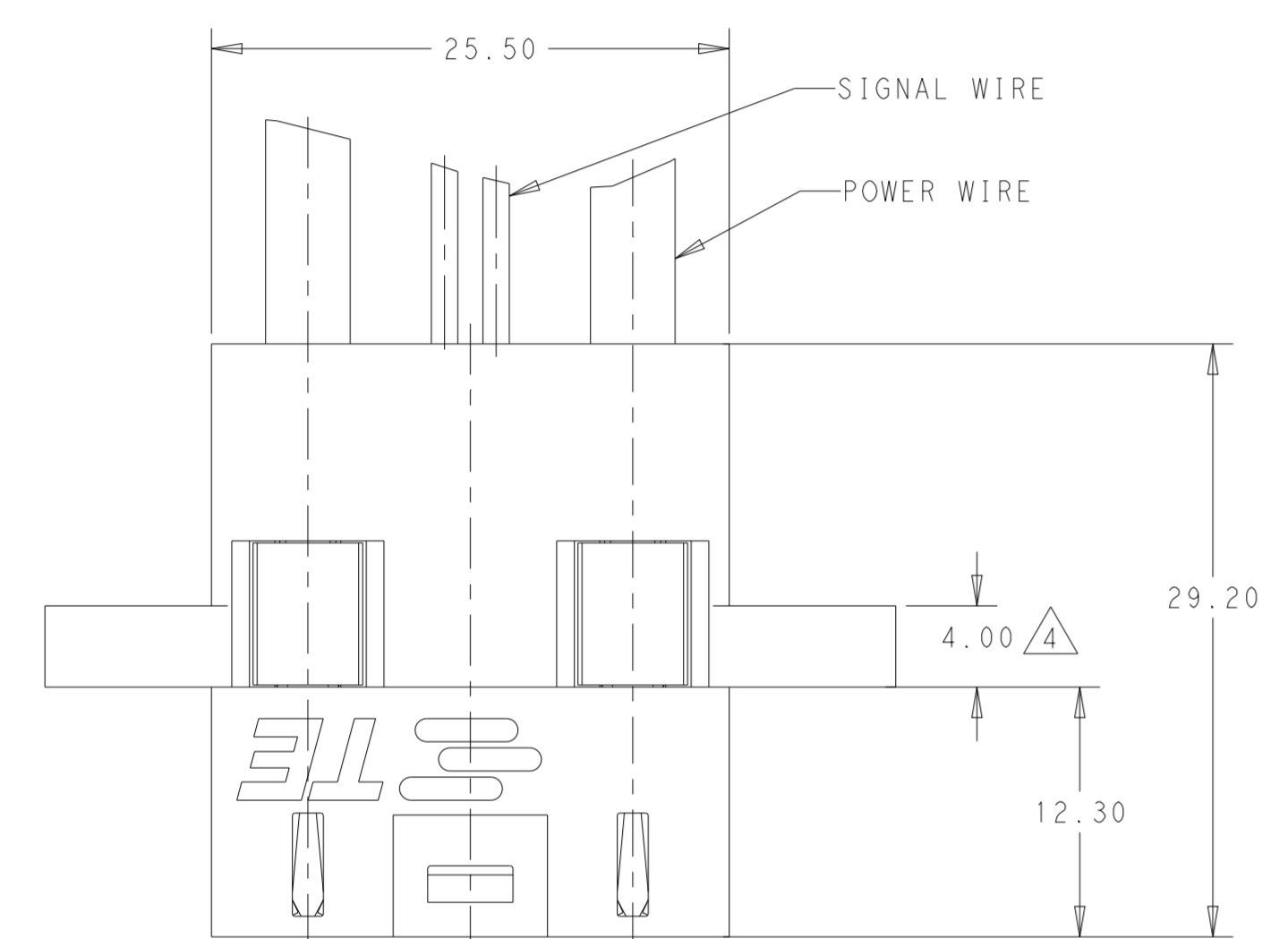

- 1 MATERIAL: CONTACTS - COPPER ALLOY  
 HOUSINGS - THERMOPLASTIC, UL94 V-0  
 MAIN HOUSING COLOR: ORANGE  
 CONTACT LOCKS COLOR: WHITE  
 POWER WIRE - STRANDED COPPER WITH SILICONE JACKET, RATED TO 200°C  
 COLOR: RED OR BLACK AS SHOWN  
 SIGNAL WIRE - STRANDED COPPER, 24 AWG.  
 COLOR: WHITE
- 2 FINISH: NICKEL UNDERPLATE ALL OVER.  
 NOBLE METAL PLATING ON CONTACT FUNCTIONAL AREA.  
 TIN PLATING IN CRIMP AREA
- 3 FEATURES DESIGNED TO RETAIN M3 THIN HEX NUT (DIN 439)
- 4 DIMENSIONS DO NOT APPLY TO 2332801-1 THROUGH 2332801-4
- 5 PART NUMBER AND DATECODE TO BE MARKED IN AREA SHOWN.

WIRE SIZE	PANEL MOUNT FEATURES	PART NO.
8 AWG	YES	2332801-8
10 AWG	YES	2332801-7
12 AWG	YES	2332801-6
14 AWG	YES	2332801-5
8 AWG	NO	2332801-4
10 AWG	NO	2332801-3
12 AWG	NO	2332801-2
14 AWG	NO	2332801-1

THIS DRAWING IS A CONTROLLED DOCUMENT.

DWN	K. MILLER	01OCT2018
CHK	N. RUFFINI	01OCT2018
APVD		
PRODUCT SPEC	108-163021	
APPLICATION SPEC	114-163021	
WEIGHT	-	
CUSTOMER DRAWING	SCALE 3:1	SHEET 1 OF 1

NAME: UMP, PLUG, WITH SIGNAL, CONNECTOR ASSEMBLY

SIZE: A2 CAGE CODE: 00779 DRAWING NO: C-2332801

RESTRICTED TO: -

REV A