

ORDER NO.	WOODHEAD NO.	COLOR
130145-0060	28T81	BLACK

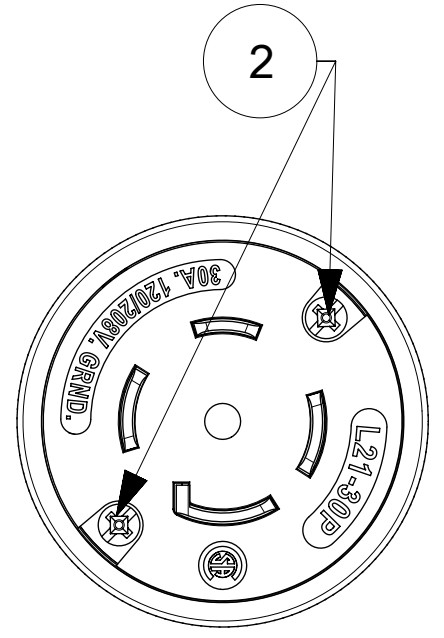

FACE VIEW

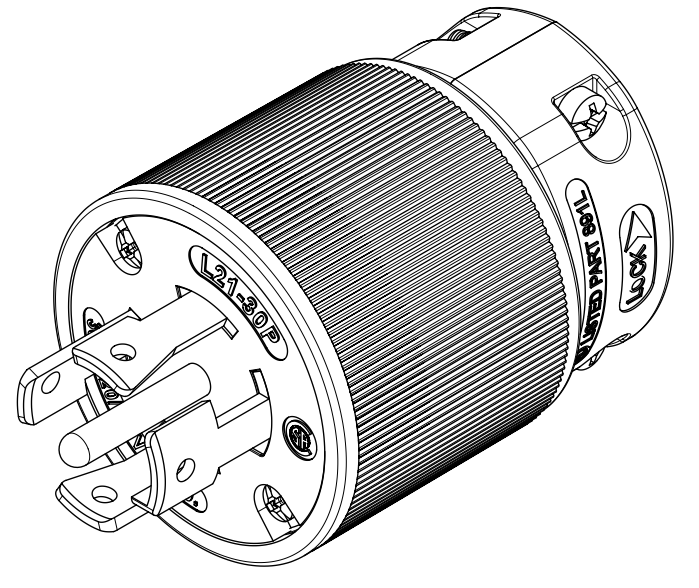
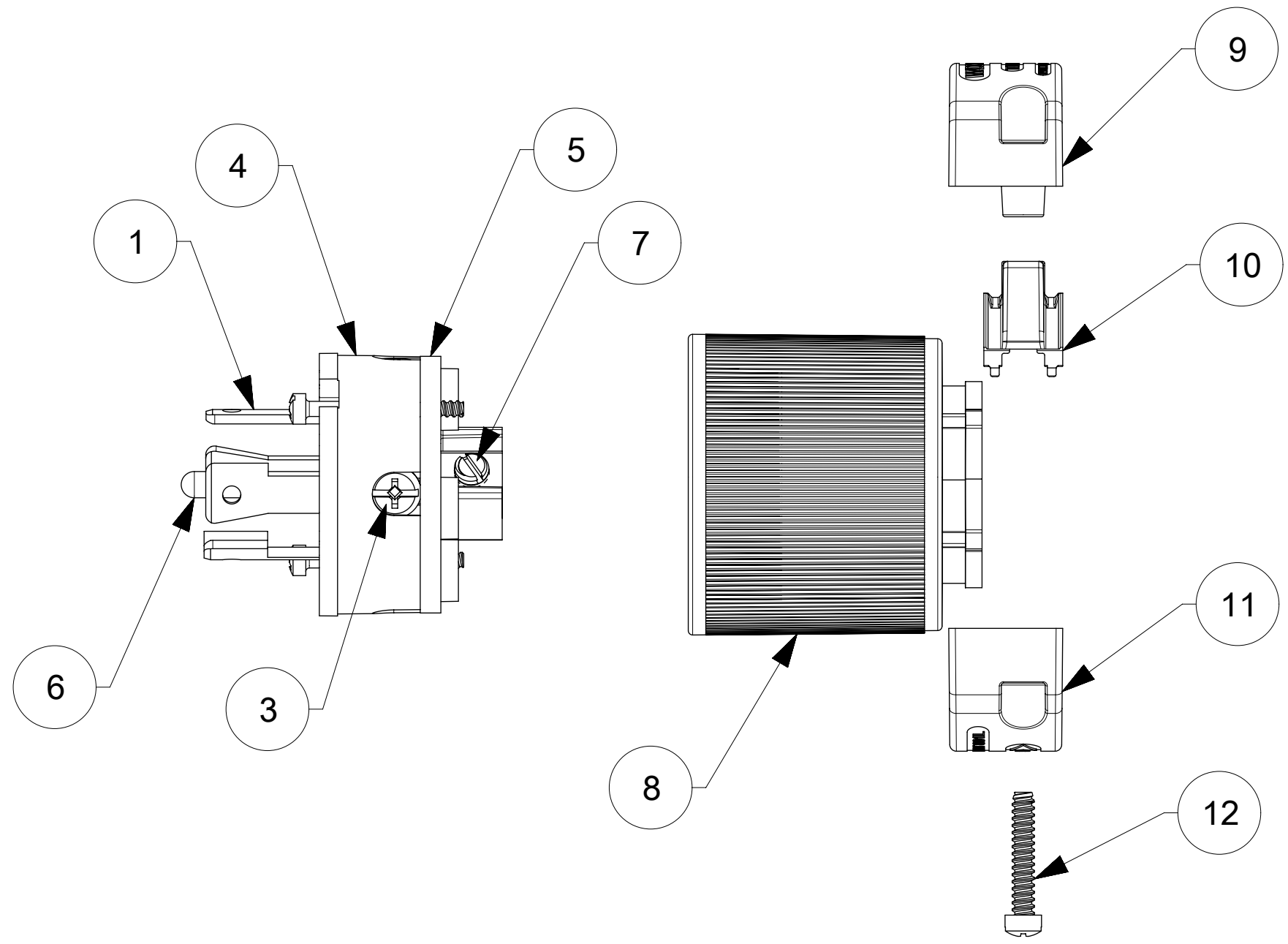
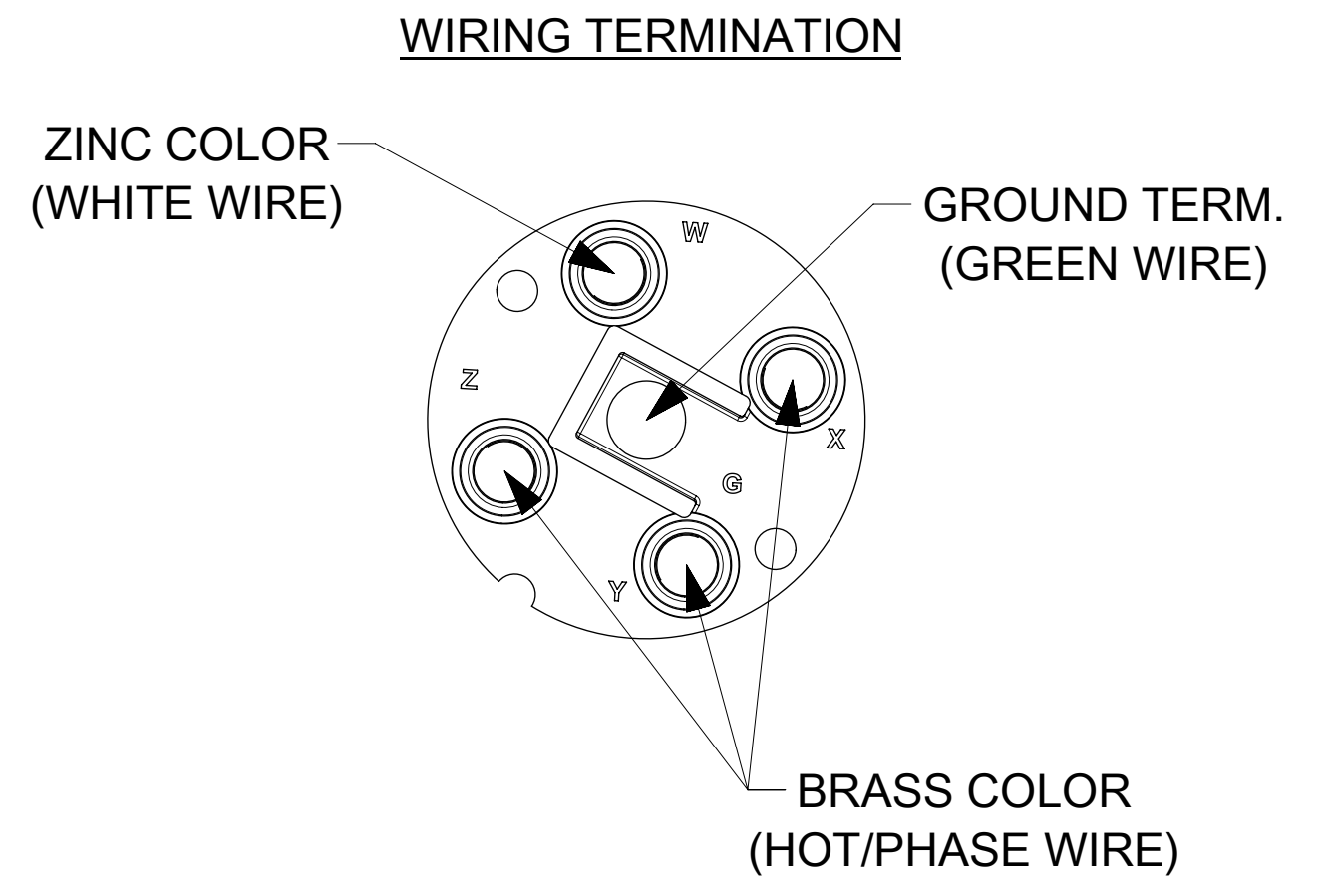
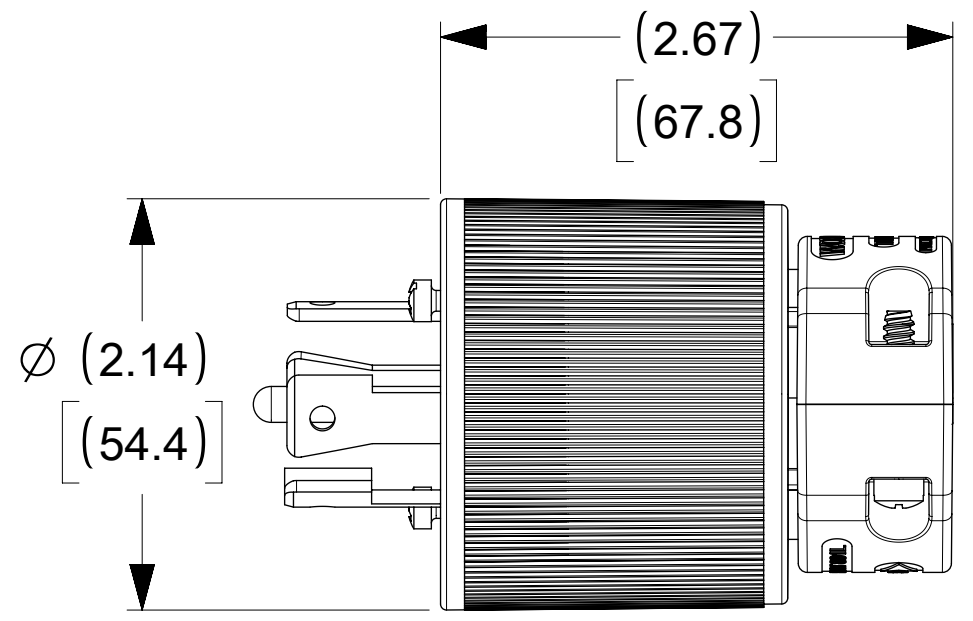

ITEM NO.	DESCRIPTIONS	MATERIAL	QTY.
1	BLADES	BRASS	4
2	RETAINING SCREWS	STAINLESS STEEL	2
3	TERMINAL SCREWS/CLAMP ASSEMBLY	BRASS, ZINC PLATED	4
4	INSERT	NYLON	1
5	TERMINAL COVER	POLYCARBONATE	1
6	GROUND PIN	BRASS, NICKEL PLATED	1
7	SET SCREW	STAINLESS STEEL	1
8	HOUSING	NYLON	1
9	CLAMP CORD MALE	NYLON	1
10	CLAMP CORD INSERT	NYLON	1
11	CLAMP CORD FEMALE	NYLON	1
12	RETAINING SCREWS	STAINLESS STEEL	2

<b>SYMBOLS</b> DIMENSION UNITS: INCH[MM] SCALE: NTS GENERAL TOLERANCES (UNLESS SPECIFIED): 4 PLACES ± 3 PLACES ± 2 PLACES ± 1 PLACE ± 0 PLACES ± ANGULAR TOL ± ° DRAFT WHERE APPLICABLE MUST REMAIN WITHIN DIMENSIONS	THIS DRAWING CONTAINS INFORMATION THAT IS PROPRIETARY TO MOLEX ELECTRONIC TECHNOLOGIES, LLC AND SHOULD NOT BE USED WITHOUT WRITTEN PERMISSION CURRENT REV DESC: NEW RELEASE		
	EC NO: 621489 DRWN: VBASUTHKARP 2018/12/12 CHK'D: DNGUYEN62 2019/12/02 APPR: HKNEELAND 2020/01/13		
INITIAL REVISION: DRWN: VBASUTHKARP 2018/12/12 APPR: HKNEELAND 2020/01/13			PRODUCT CUSTOMER DRAWING DOCUMENT NUMBER: 1301450060 DOC TYPE: PSD DOC PART: 000 REVISION: A
THIRD ANGLE PROJECTION 		DRAWING SERIES: C-SIZE 130145	MATERIAL NUMBER: SEE TABLE CUSTOMER: GENERAL MARKET SHEET NUMBER: 1 OF 1