

PART NUMBER	REVISION	DESCRIPTION	FEED TYPE
2266257-2	G	FINE CRIMP HEIGHT ADJUST	PNEUMATIC
7-2266257-2	G	PNEUMATIC AND CRIMP TOOLING KIT	PNEUMATIC
7-2266257-7	D	CRIMP TOOLING KIT	-

ATLANTIC VERSION TERMINATOR INTERFACE ADAPTER

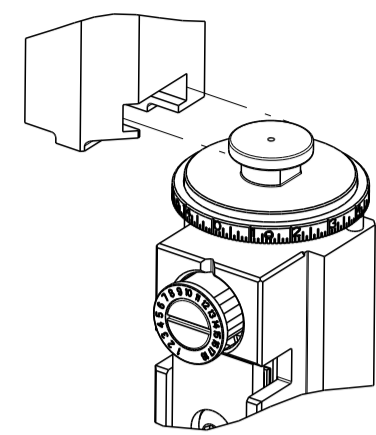

APPLICATOR DATA		
CRIMP	SIZE	TYPE
WIRE	5.33 mm [.210]	F
INSUL	12.50 mm [.492]	O

APPLICATOR INSTRUCTIONS
408-35042

TERMINAL DATA: TE TERMINAL		TE CRIMP SPECIFICATION	
TERMINAL NAME: MECON 8 CONTACT			
WIRE STRIP LENGTH	SEAL COLLAR DIA RANGE		
8.30-8.90 mm [.327-.350 IN]	10 mm [.394 IN]		
TERMINAL APPLICATION SPECIFICATION	114-94761		

TERMINALS APPLIED				SEAL INSULATION DIAMETER RANGE
TE TERMINAL	TE TERMINAL	TE SEAL	LEAR SEAL	
1-2208766-3			13214 627 619	4.0-4.5mm
			13213 627 642	3.4-3.8mm

WIRE SIZE	CRIMP HEIGHT mm [INCH]	CRIMP HEIGHT REFERENCE SETTING
6.00mm2	2.70 +/- 0.05 [.106 +/- .002]	12.5
4.00mm2	2.42 +/- 0.05 [.095 +/- .002]	15.3

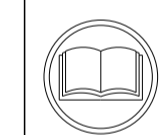

- RECOMMENDED SPARE PARTS
- REFER TO SUPPLIED INSTRUCTION SHEET FOR CLEANING, LUBRICATION AND STORAGE OF APPLICATOR.
- APPLY PART NUMBER 2-23419-6 LOCTITE TO THREADS OF ITEM 242.
- CRIMP HEIGHT REFERENCE SETTING WAS THE SETTING USED WHEN THE APPLICATOR WAS QUALIFIED AT THE FACTORY. ADJUSTMENT MAY BE NECESSARY WHEN RUNNING APPLICATOR IN THE FIELD.
- UNLESS SPECIFIED OTHERWISE TORQUE VALUES SHALL BE USED PER DOCUMENT, 101-35000.
- TERMINAL PITCH NOT COMPATIBLE WITH MECHANICAL FEED.
- CUT TO LENGTH AT ASSEMBLY.
- FOR BEST RESULTS, WIRE MUST BE PLACED INTO WIRE BARREL PRIOR TO CRIMPING.

***WARNING**
ON INSTALLATION, SET WIRE DISC TO CRIMP HEIGHT REFERENCE SETTING FOR LARGEST WIRE SIZE. CRIMP HEIGHT REFERENCE SETTINGS GREATER THAN THE VALUE SHOWN MAY CAUSE DAMAGE TO THE CRIMP TOOLING, REFER TO THE INSTRUCTION SHEET FOR PROPER SETUP AND ADJUSTMENTS.

ATLANTIC VERSION
Shown on sheets 1 of 4 & 2 of 4
(Pacific version shown on sheets 3 of 4 & 4 of 4)

LOC	DIST	REVISIONS					
A	66	P	LTN	DESCRIPTION	DATE	OWN	APVD
		E		ECR-19-002571	18FEB2019	FJ	CT
		F		ECR-22-136653	21APR2022	FZ	JH
		G		ECR-22-146922	21JUL2022	FZ	TE
		G1		ECR-22-155430	13OCT2022	FZ	MP

-	2	2	2168083-1	SCR, SKT HD CAP, RoHS, M3 X 8.0	269	
-	1	1	1633782-4	FENCE	267	
-	1	1	2119641-1	FEED CAM, AIR FEED	248	
-	1	1	2119082-7	CAM, SNAIL, INSULATION ADJUSTMENT	244	
-	1	1	2079764-1	WASHER, WAVE SPRING, CREST-TO-CREST	243	
-	1	1	2119083-1	RETAINER, INSULATION DIAL	242	
-	1	1	7-18023-7	SCR, SKT HD CAP M3 X 4.0	241	
-	1	1	2844940-2	AIR FEED MODULE	238	
-	REF	REF	994970-2	COUNTER, MAGNETIC	164	
-	1	1	1-22281-8	SPRING, COMPRESSION	121	
-	1	1	2844908-1	SCREW, LOCKING	99	
-	1	1	2844907-1	POST, LOCKING	98	
-	1	1	1-690438-0	FRONT STRIP GUIDE	96	
-	2	2	2168083-1	SCR, SKT HD CAP, RoHS, M3 X 8.0	95	
-	1	1	2168083-6	SCR, SKT HD CAP, RoHS, M5 X 65	93	
-	1	1	2-455888-4	SPACER, CRIMPER	82	
-	2	2	2079383-4	SCR, BHSC, RoHS (M4 X 8)	79	
-	1	1	1803096-1	EXTENSION PLATE	78	
-	1	1	1803607-3	DOCUMENTATION PACKAGE	71	
-	1	1	2119791-7	DEPRESSOR, WIRE	70	
-	1	1	2119943-1	WASHER, SPACER	69	
-	1	1	2119740-1	TAG, IDENTIFICATION	67	
-	2	2	2168078-1	SCREW, DRIVE, RH, RoHS, 2 x .188	66	
-	2	2	2-18032-5	SCR, SET, FLT PNT, M5 X 20.0	61	
-	1	1	2168083-2	SCR, SKT HD CAP, RoHS, M4 X 8.0	60	
-	1	1	5-18022-5	SCR, HEX HD CAP, M4 X 6.0	59	
-	1	1	811242-6	BUMPER, HOLD DOWN	57	
-	1	1	1-1338683-1	FEED PAWL	56	
-	4	4	2168083-3	SCR, SKT HD CAP, RoHS, M4 X 12.0	54	
-	2	2	1-2168083-0	SCR, SKT HD CAP, RoHS, M4 X 10	53	
-	1	1	5018030-1	NUT, HEX, REG, RoHS, M3	52	
-	1	1	1-811242-0	BUMPER, HOLD DOWN	51	
-	1	1	690753-2	SPACER, TONKER	50	
-	1	1	18023-9	SCR, SKT HD CAP M4 X 6.0	49	
-	1	1	2-1803583-6	APPLICATOR BASIC ASSEMBLY, SF	46	
-	1	1	1803515-2	RAM ASSEMBLY, SF ATLANTIC	44	
-	1	1	1803602-1	SCR, BHSC, RoHS (M8 X 25)	41	
-	1	1	1752356-7	SUPPORT, TERMINAL	34	
-	2	2	2079383-5	SCR, BHSC, RoHS (M4 X 20)	33	
-	2	2	3-2844962-2	SPACER, CYLINDRICAL, STRIP GUIDE	30	
-	1	1	2844938-9	PLATE, STRIP GUIDE	29	
-	1	1	2-455888-8	SPACER, CRIMPER	28	
-	2	2	22283-1	SPRING, COMPRESSION	27	
-	1	1	356835-1	LEVER, DRAG RELEASE	26	
-	1	1	240792-1	DRAG, TERMINAL	25	
-	1	1	1320928-6	STRIP GUIDE	24	
-	1	1	980371-4	SCR, SKT HD SHLDR 5.0 DIA X 6.0	23	
-	1	1	2168083-2	SCR, SKT HD CAP, RoHS, M4 X 8.0	21	
-	2	2	1-18028-2	WASHER, FLAT, REG M4	20	
-	1	1	1803013-1	STRIPPER, SIDE FEED	19	
-	1	1	2119806-1	INSERT, SHEAR	13	
-	1	1	3-22280-3	SPRING, COMPRESSION	12	
-	1	1	1-356885-4	STOP, SHEAR	11	
-	1	1	2-2119805-0	SHEAR HOLDER, FRONT	10	
-	1	1	1-318059-2	FLOATING SHEAR, FRONT	9	
-	1	2	1	2-1633930-3	ANVIL, COMBINATION	8
-	-	-	-	-	7	
-	-	-	-	-	6	
-	1	1	1-1803080-2	DEPRESSOR, SHEAR	5	
-	1	1	2-238011-7	BLOCK, CRIMPER SPACER	4	
-	1	2	1	3-1633996-8	CRIMPER, INSULATION SPECIAL	3
-	1	1	455888-8	SPACER, CRIMPER	2	
-	1	2	1	1-1803179-2	CRIMPER, WIRE PREMIUM	1

DIMENSIONS:		TOLERANCES UNLESS OTHERWISE SPECIFIED:		MATERIAL:		FINISH:		WEIGHT:		SCALE:	
mm	0 PLC ±	1 PLC ±	2 PLC ±	3 PLC ±	4 PLC ±	ANGLES	FINISH			Customer Accessible Production Drawing	SCALE 1:2
											SHEET 1 OF 4

LOC	DIST	REVISIONS					
A	66	P	LTN	DESCRIPTION	DATE	OWN	APVD
		-		SEE SHEET 1	-	-	-

FEED TYPE

PNEUMATIC

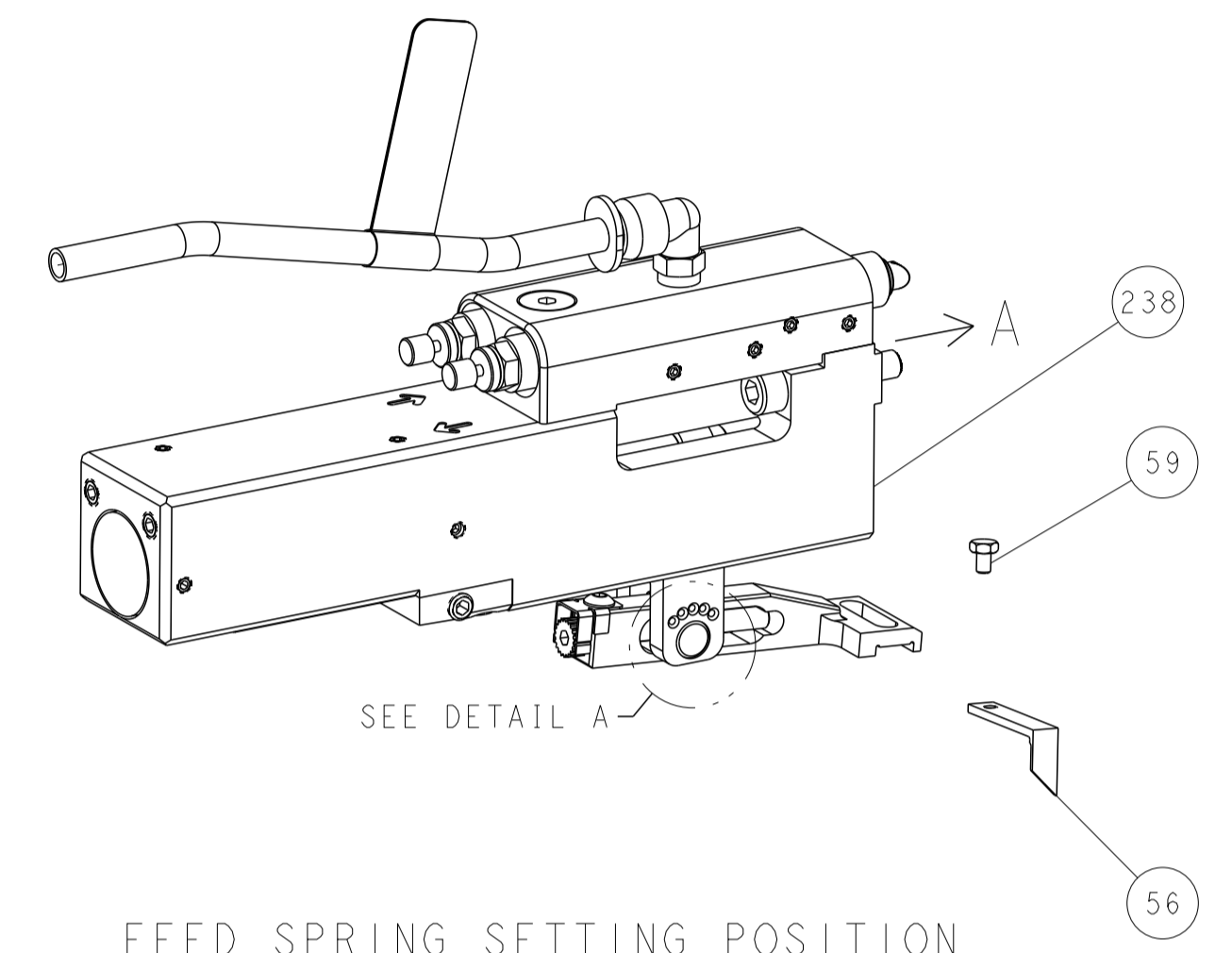

FEED SPRING SETTING POSITION
(SHOWN FROM REAR SIDE)

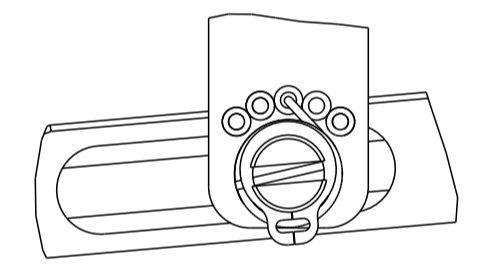

DETAIL A

CAM POSITION

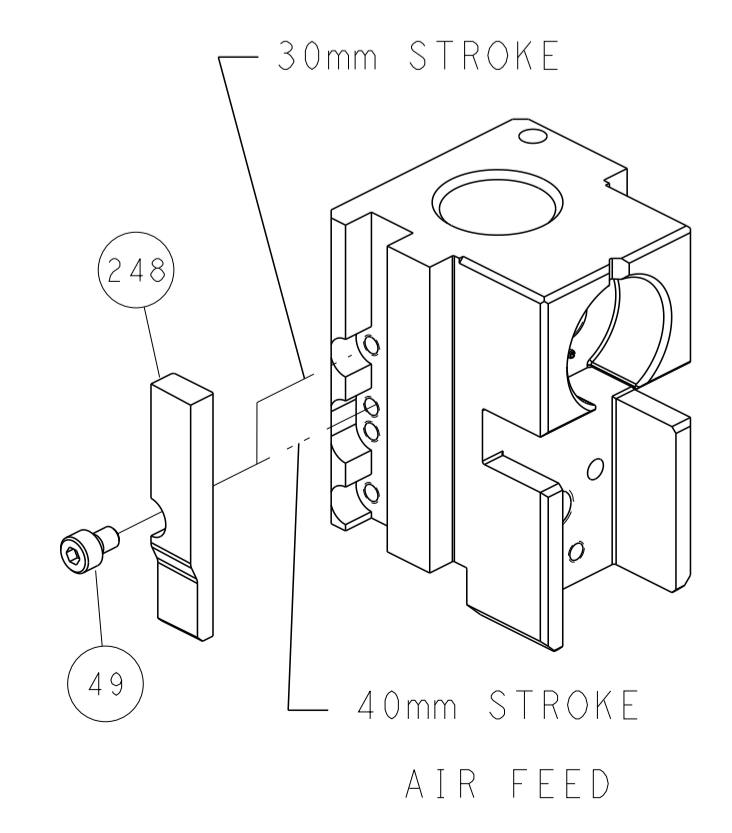

AIR FEED

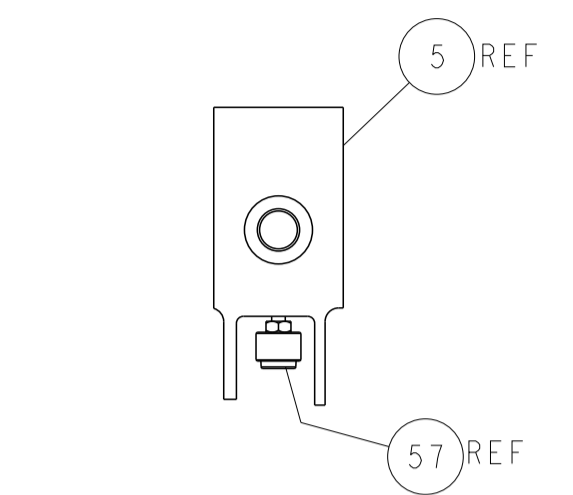
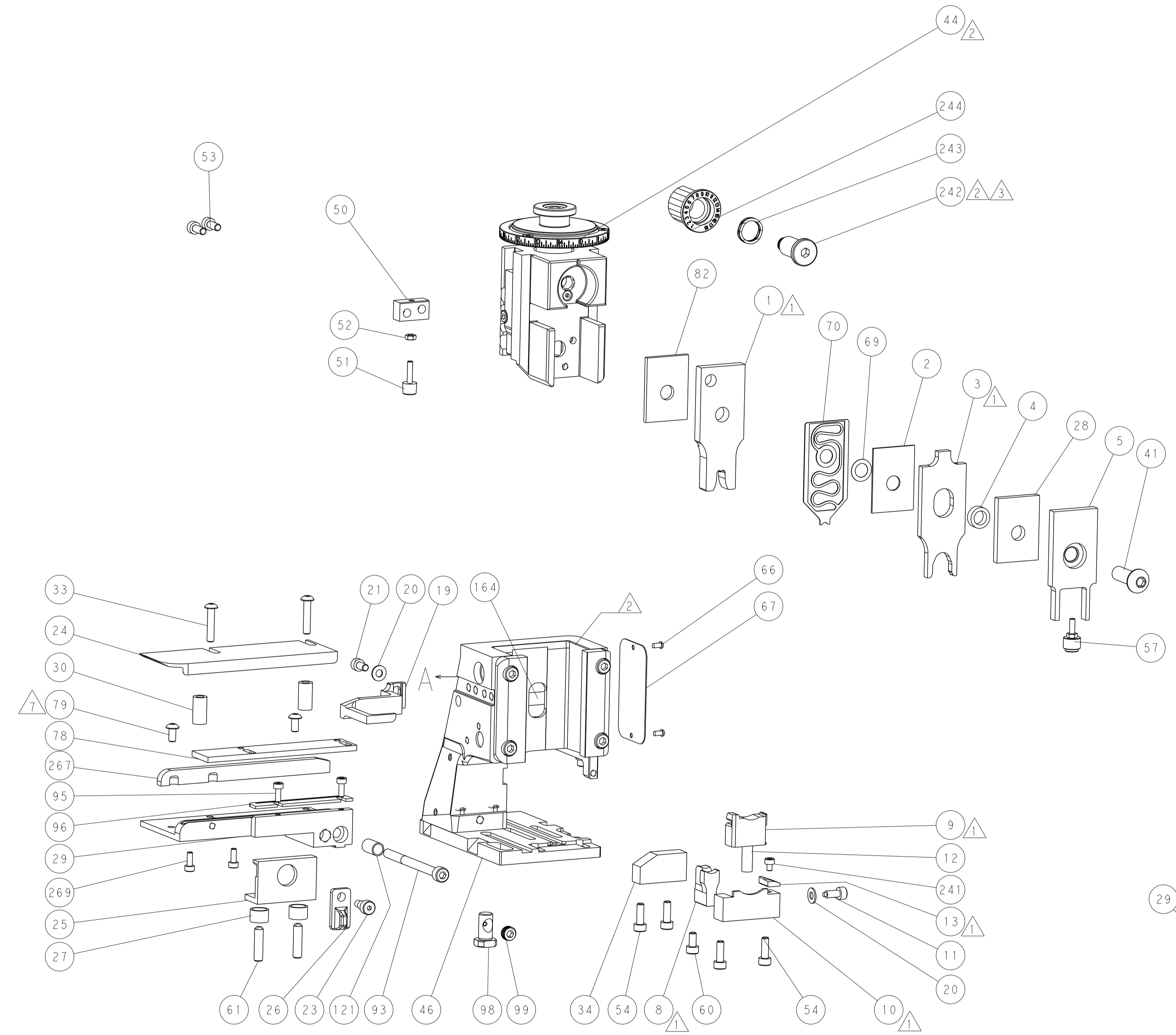

SHEAR DEPRESSOR DETAIL

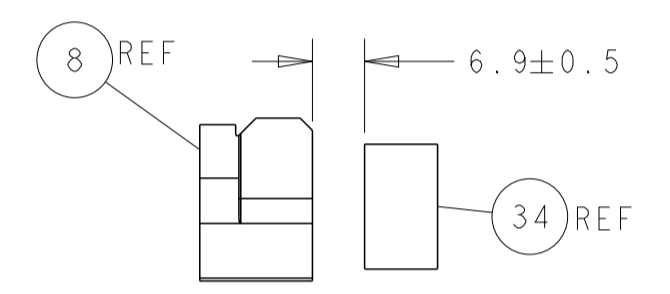

TERMINAL SUPPORT LOCATION

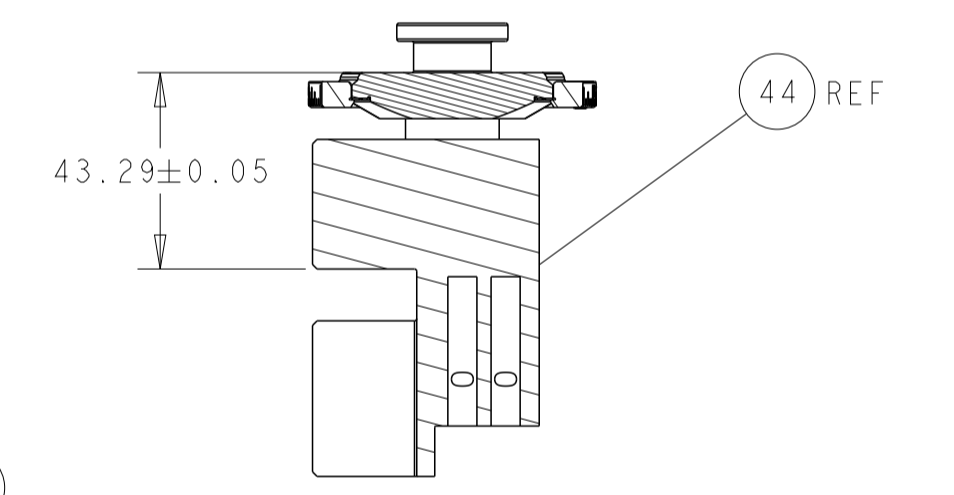

RAM SET-UP

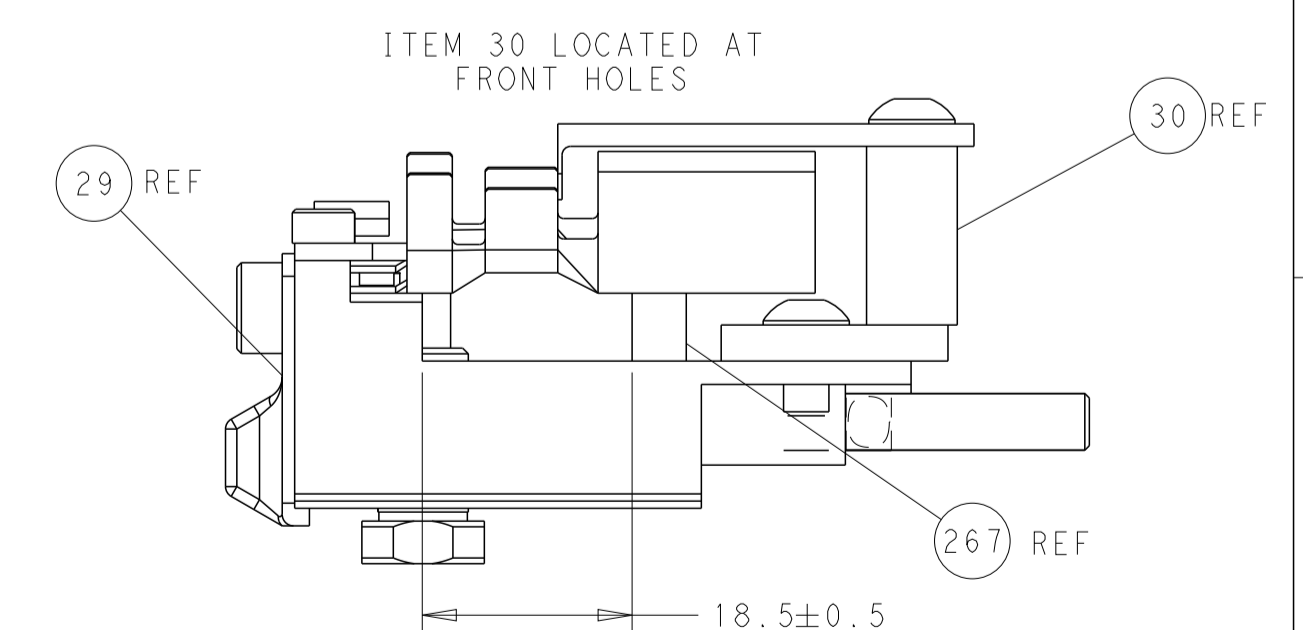

FEED TRACK POSITION GUIDE BY WIRE BARREL

ATLANTIC VERSION
 Shown on sheets 1 of 4 & 2 of 4
 (Pacific version shown on sheets 3 of 4 & 4 of 4)

<small>THIS DRAWING IS UNPUBLISHED. RELEASED FOR PUBLICATION BY TYCO ELECTRONICS CORPORATION. ALL RIGHTS RESERVED.</small>		DWN R.O. WILSON 19MAY2014 CHK K.J. STAKEM 22MAY2014 APVD T.L. ELBIN 22MAY2014	NAME Ocean Side Feed Applicator PRODUCT SPEC APPLICATION SPEC SIZE CAGE CODE DRAWING NO. RESTRICTED TO A1 00779 C=2266257
DIMENSIONS: mm TOLERANCES UNLESS OTHERWISE SPECIFIED: 0 PLC ± 1 PLC ± 2 PLC ± 3 PLC ± 4 PLC ± ANGLES ± MATERIAL FINISH	WEIGHT SCALE 1:2 SHEET 2 OF 4 REV G1	TE Connectivity Harrisburg, PA 17105-3608	Customer Accessible Production Drawing

LOC	DIST	REV	DATE	BY	APPV
A	66				
REVISIONS			DESCRIPTION	DATE	BY
			SEE SHEET 1		

FEED TYPE

PNEUMATIC

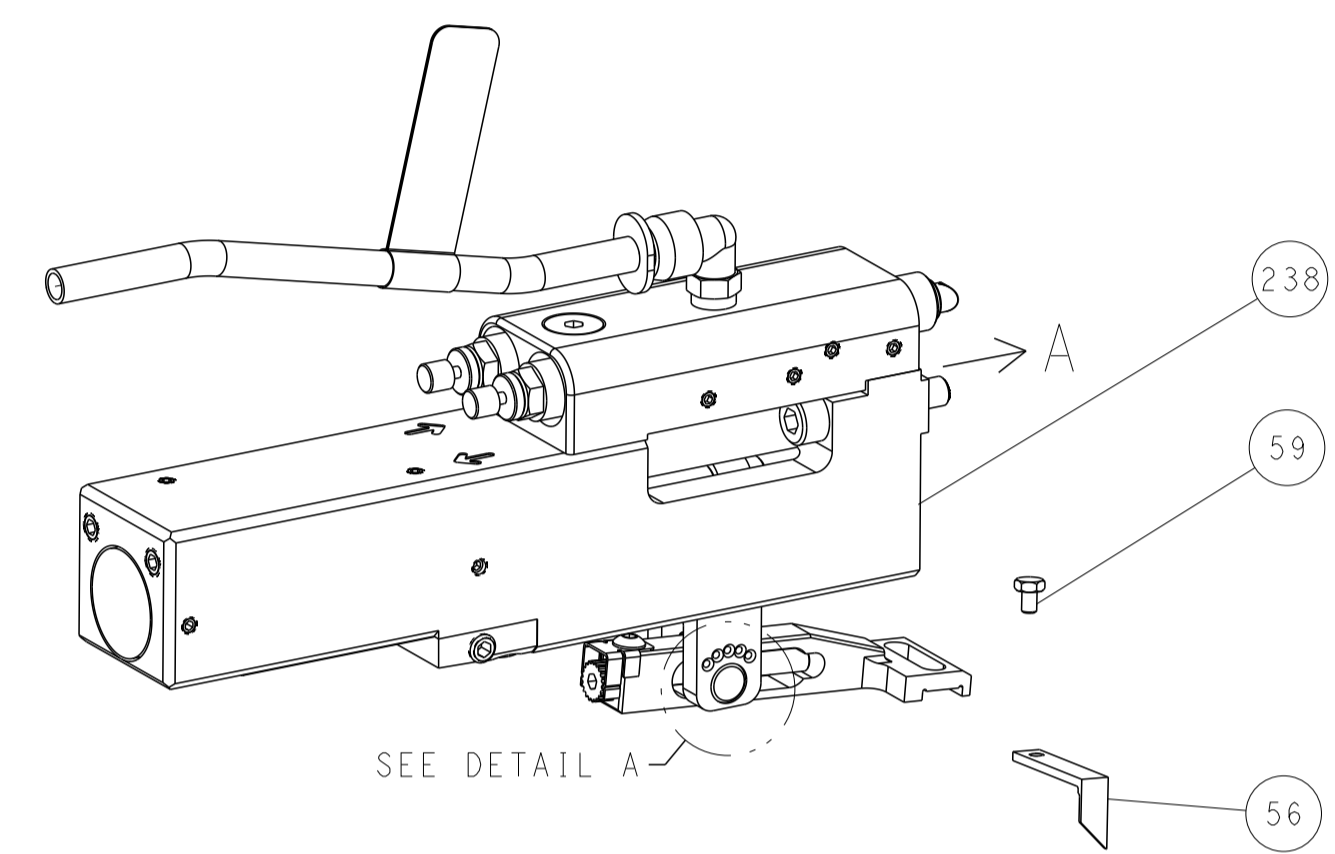

SEE DETAIL A

FEED SPRING SETTING POSITION (SHOWN FROM REAR SIDE)

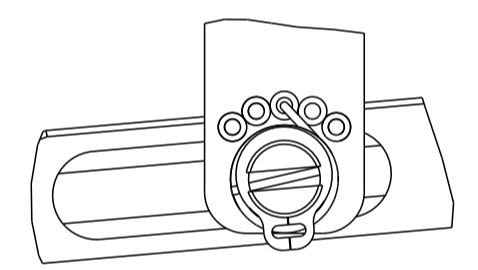

DETAIL A

CAM POSITION

30mm STROKE

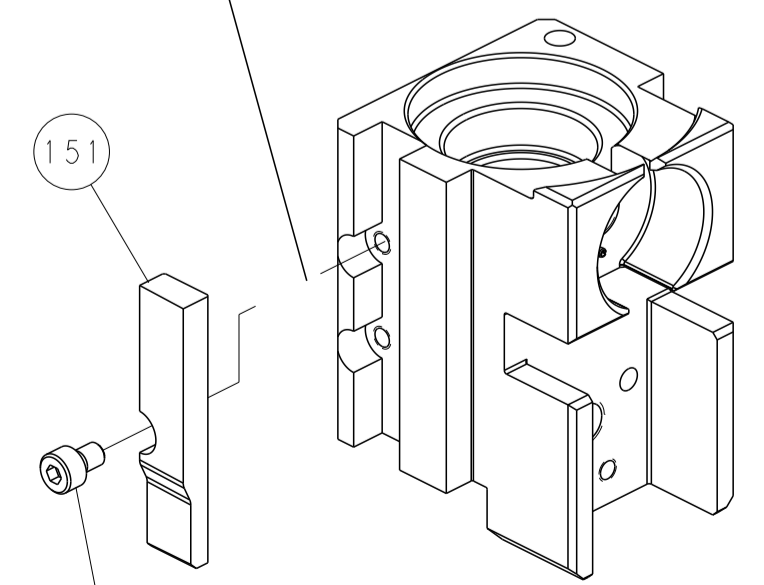

AIR FEED

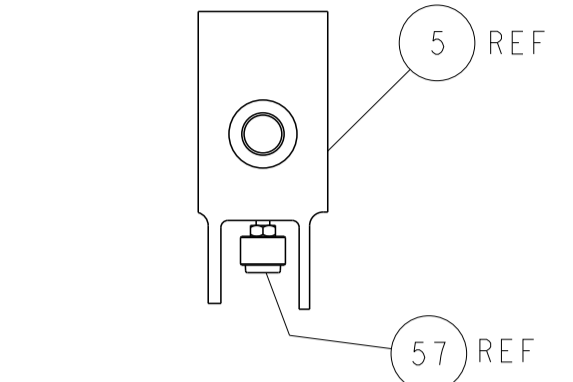
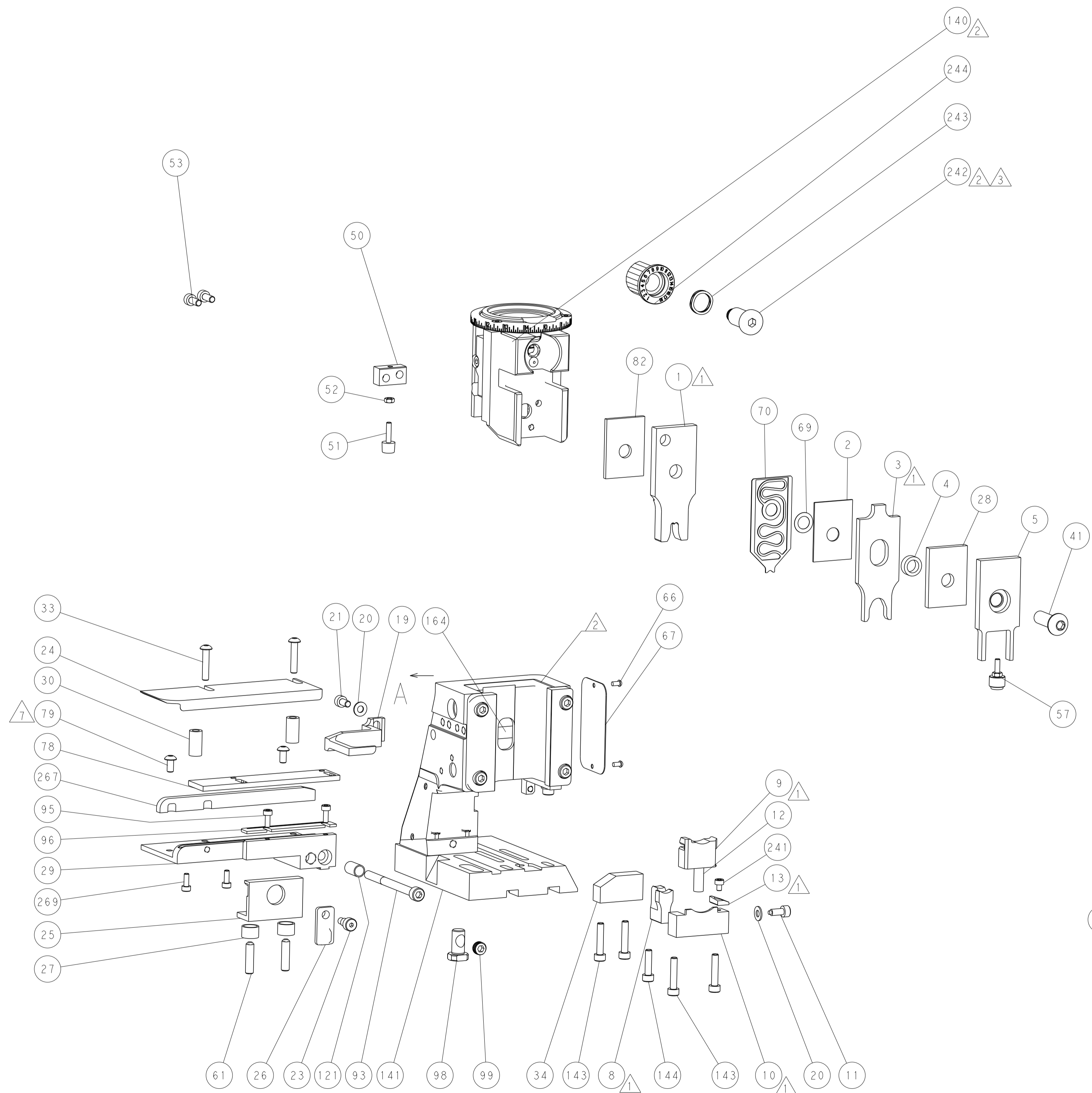

SHEAR DEPRESSOR DETAIL

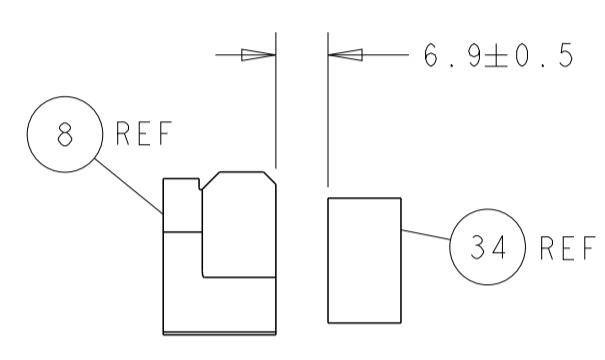

TERMINAL SUPPORT LOCATION

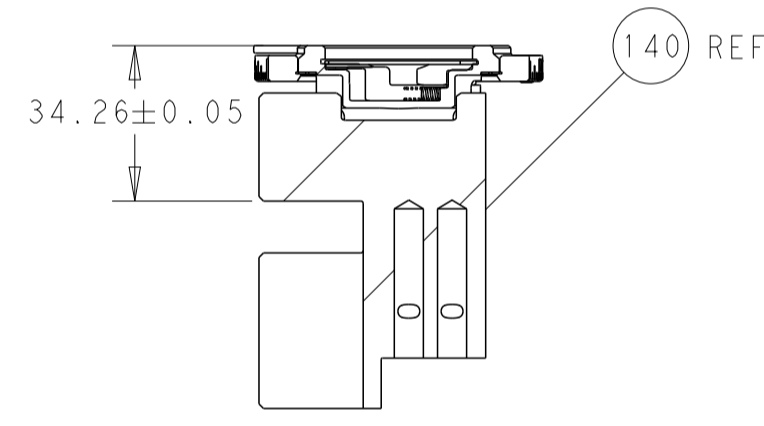

RAM SET-UP

ITEM 30 LOCATED AT
FRONT HOLES

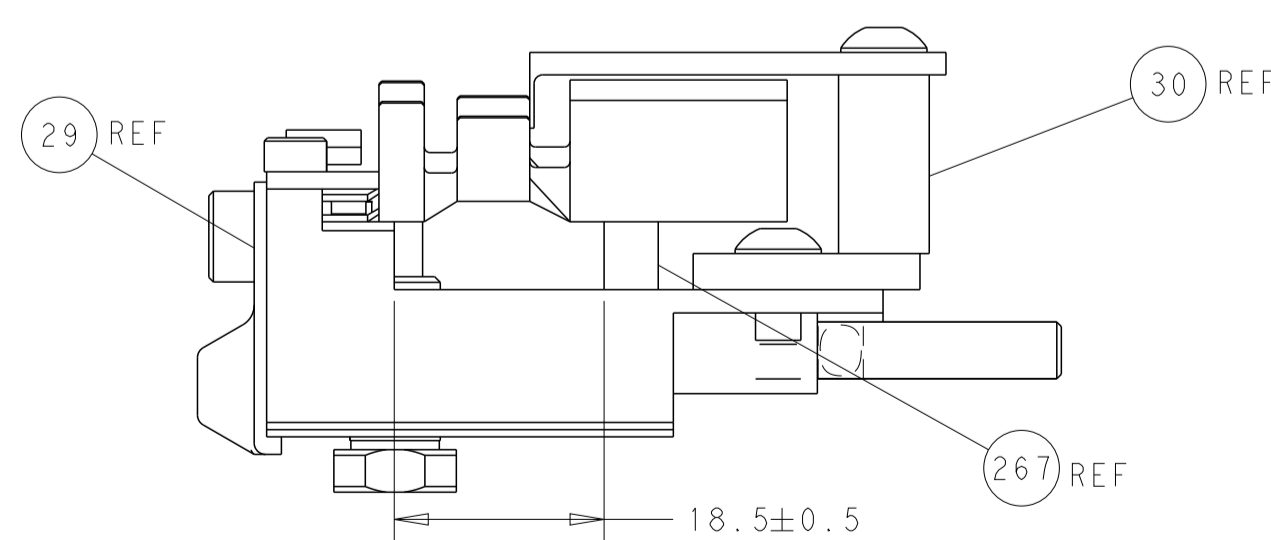

FEED TRACK POSITION
GUIDE BY WIRE BARREL

PACIFIC VERSION
 Shown on sheets 3 of 4 & 4 of 4
 (Atlantic version shown on sheets 1 of 4 & 2 of 4)

<small>THIS DRAWING IS UNPUBLISHED. RELEASED FOR PUBLICATION. 20 COPYRIGHT 20 BY TYCO ELECTRONICS CORPORATION. ALL RIGHTS RESERVED.</small>		DWN: R.O. WILSON CHK: K.J. STAKEM APVD: T.L. ELBIN	19MAY2014 22MAY2014 22MAY2014	TE Connectivity Harrisburg, PA 17105-3608
DIMENSIONS: mm TOLERANCES UNLESS OTHERWISE SPECIFIED: 0 PLC ± 1 PLC ± 2 PLC ± 3 PLC ± 4 PLC ± ANGLES ± MATERIAL: - FINISH: -		NAME: Ocean Side Feed Applicator PRODUCT SPEC: - APPLICATION SPEC: - WEIGHT: - SCALE: 1:2	SIZE: A1 CAGE CODE: 00779 DRAWING NO: 2266257 SHEET 4 OF 4 REV G1	RESTRICTED TO: -