

△9  
 トレードマーク、金型番号およびキャビティ番号  
 TRADE MARK, MOLD & CAVITY NO.  
 ※シート3注記参照  
 ※SEE NOTE ON SHEET 3.

△4  
 PICK UP AREA

△4  
 金具  
 FITTING NAIL

△9  
 金型番号及びキャビティ番号  
 MOLD & CAVITY NO.

△9  
 トレードマーク  
 TRADE MARK

28.1	24.5	29.7	5052785033	50
25.6	22	27.2	5052784533	45
23.1	19.5	24.7	5052784033	40
20.6	17	22.2	5052783533	35
18.1	14.5	19.7	5052783033	30
C	B	A	EMBOSSED PACKAGE	Ckt
			オーダー番号 ORDER NO.	

CONNECTOR SERIES NO. 505278\*\*22

THIS DRAWING CONTAINS INFORMATION THAT IS PROPRIETARY TO MOLEX ELECTRONIC TECHNOLOGIES, LLC AND SHOULD NOT BE USED WITHOUT WRITTEN PERMISSION

REVISED	2017/06/09	2017/06/12	2017/06/12	GENERAL TOLERANCES (UNLESS SPECIFIED)	DIMENSION UNITS	SCALE	
	2017/06/09	2017/06/12	2017/06/12		MM	8:1	
	2017/06/09	2017/06/12	2017/06/12		ANGULAR TOL ± 1.0 °	DRWN BY	DATE
	2017/06/09	2017/06/12	2017/06/12		4 PLACES ± 0.2	JASANUMA	2016/03/14
	2017/06/09	2017/06/12	2017/06/12		3 PLACES ± 0.2	CHK'D BY	DATE
2017/06/09	2017/06/12	2017/06/12	2 PLACES ± 0.2	KTAKAHASHI	2016/03/18		
2017/06/09	2017/06/12	2017/06/12	1 PLACE ± 0.25	APPR BY	DATE		
2017/06/09	2017/06/12	2017/06/12	0 PLACES ± 0.3	NUKITA	2016/03/23		
EC NO: 117930	DRWN: JASANUMA	CHK'D: YKOBAYASHI02	APPR: TKUSUHARA01	DRAFT WHERE APPLICABLE MUST REMAIN WITHIN DIMENSIONS	DRAWING SIZE	THIRD ANGLE PROJECTION	
D	REV				A3		

**molex**<sup>®</sup>

0.5 FFC CONN ZIF E/O BTM CONT TYPE ASSY

PRODUCT CUSTOMER DRAWING

SERIES	MATERIAL NUMBER	CUSTOMER
505278	SEE CHART	GENERAL
DOCUMENT NUMBER	DOC TYPE	DOC PART
5052781001	PSD	000
SHEET NUMBER		
1 OF 3		

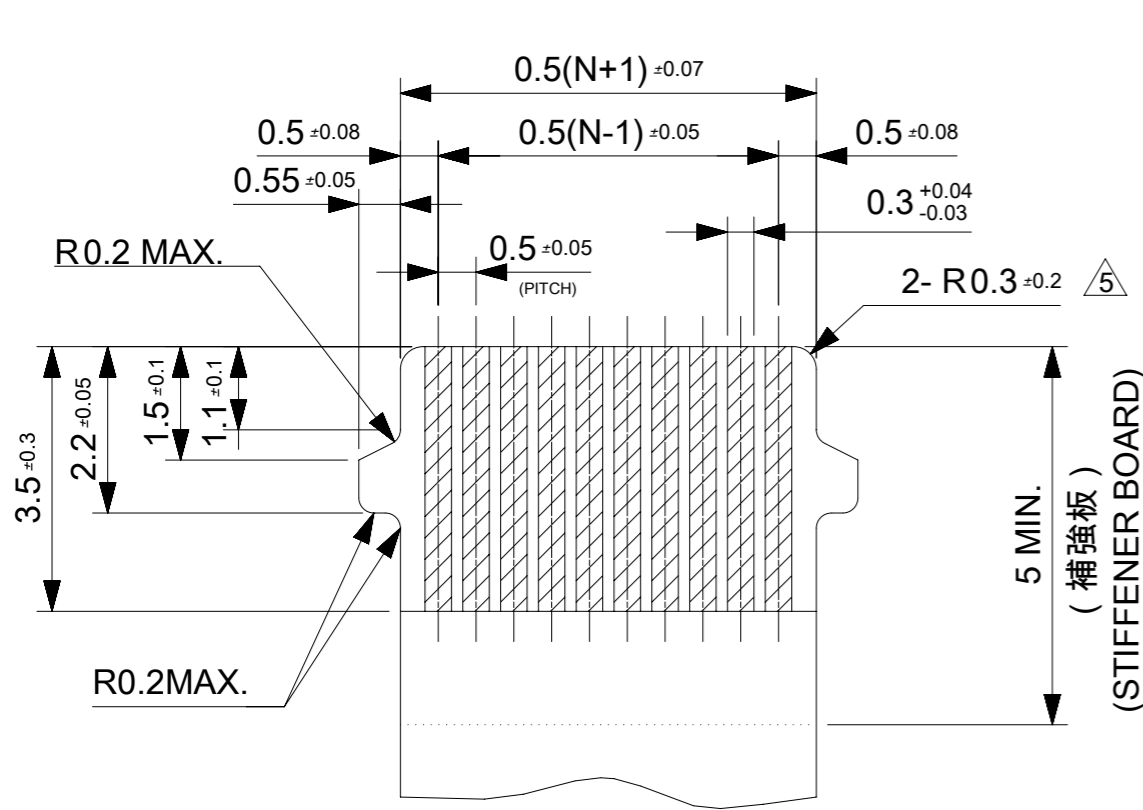

適合FPC/FFC推奨寸法  
APPLICABLE FPC/FFC  
RECOMMENDED DIMENSION

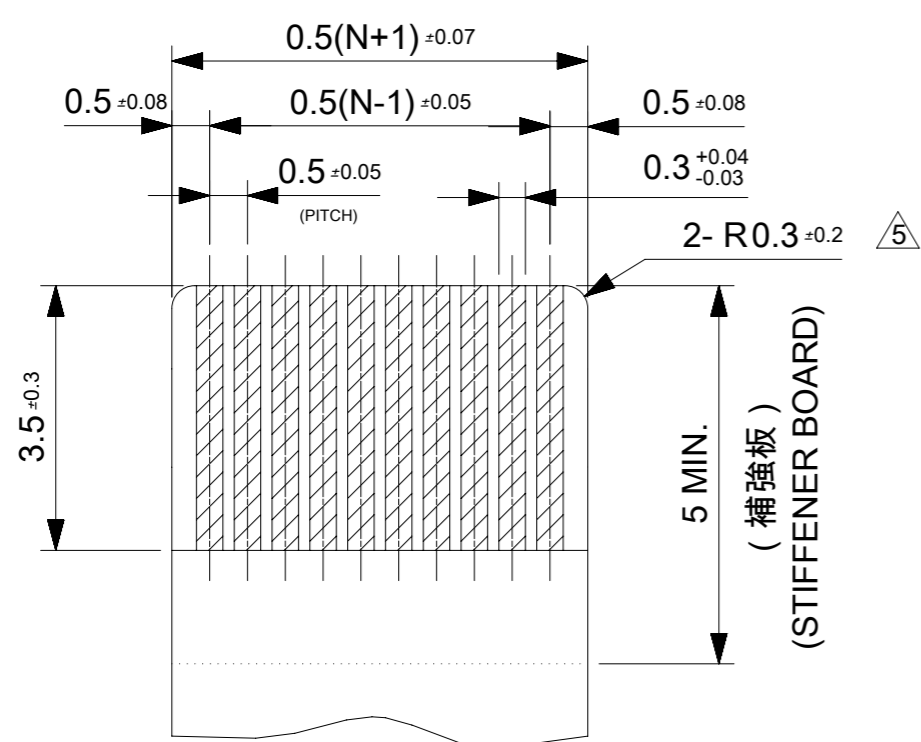

耳無し適合FPC/FFC推奨寸法  
APPLICABLE NON-TAB FPC/FFC  
RECOMMENDED DIMENSION

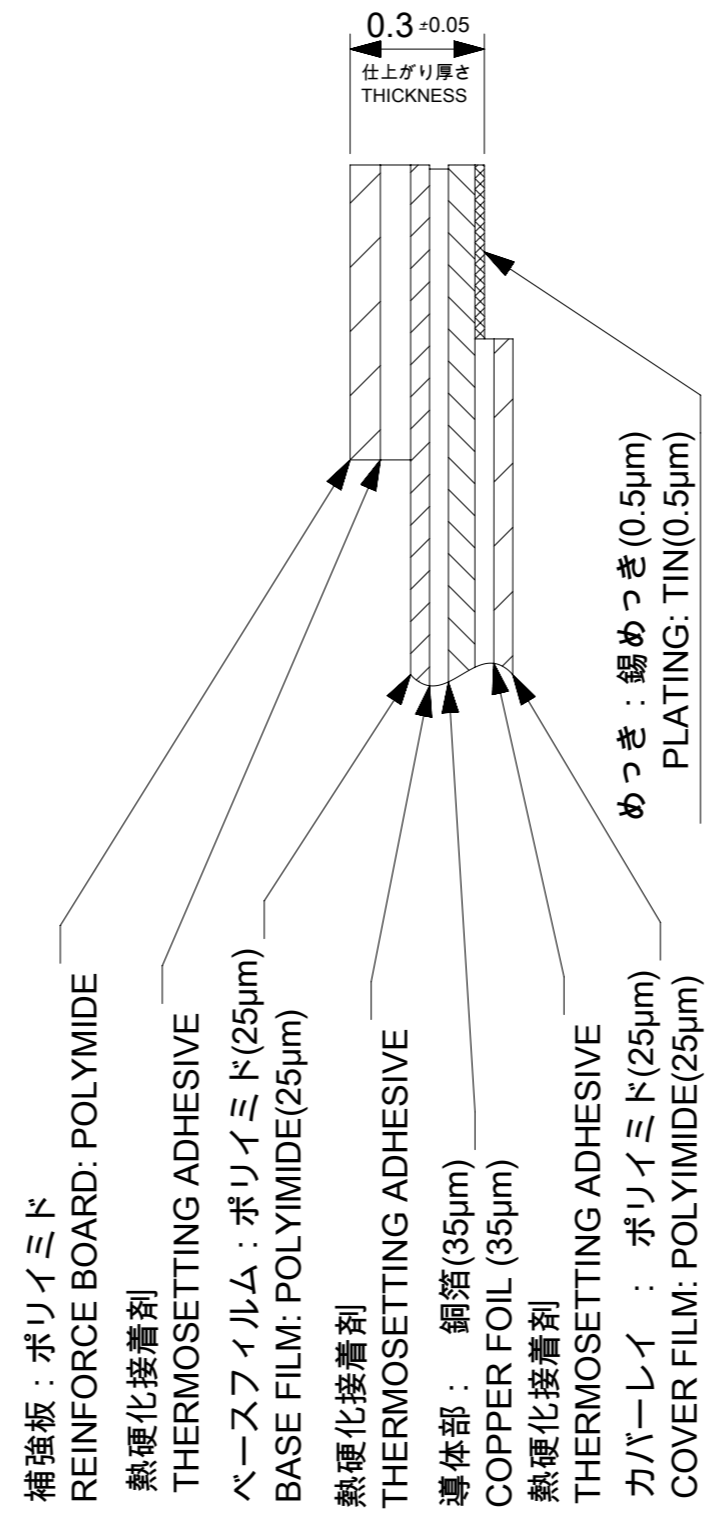

FPC構成推奨仕様  
STRUCTURE OF FPC

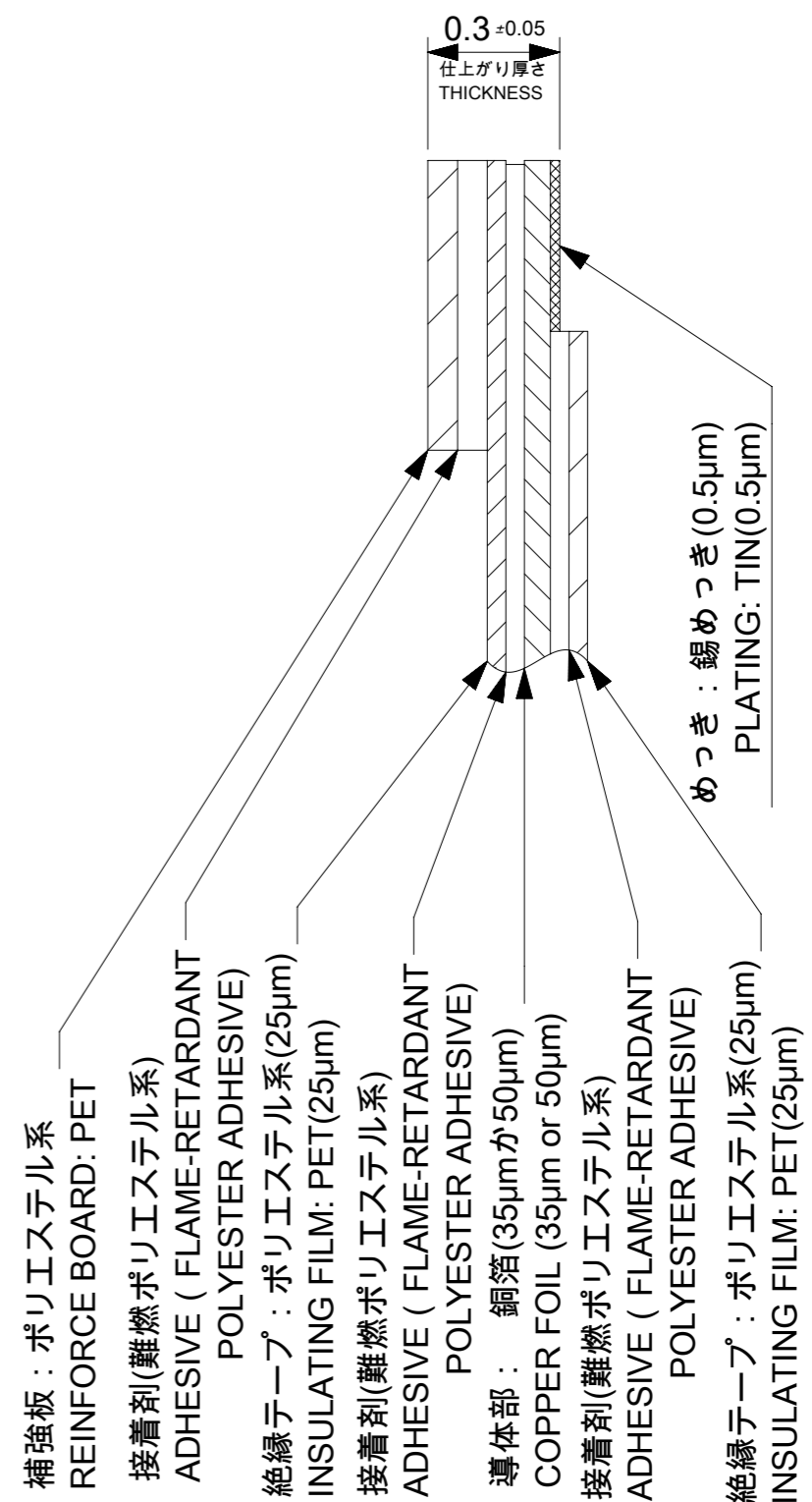

FFC構成推奨仕様  
STRUCTURE OF FFC

THIS DRAWING CONTAINS INFORMATION THAT IS PROPRIETARY TO MOLEX ELECTRONIC TECHNOLOGIES, LLC AND SHOULD NOT BE USED WITHOUT WRITTEN PERMISSION										
REVISED	EC NO: 117930	DRWN: JASANUMA	CHK'D: YKOBAYASHI02	APPR: TKUSUHARA01	2017/06/09	2017/06/12	2017/06/12	GENERAL TOLERANCES (UNLESS SPECIFIED)		
	4 PLACES		± 0.2		ANGULAR TOL ± 1.0 °		DIMENSION UNITS		SCALE	
	3 PLACES		± 0.2		DRAWN BY		DATE		MM	≠≠
	2 PLACES		± 0.2		CHK'D BY		DATE		JASANUMA	2016/03/14
	1 PLACE		± 0.25		APPR BY		DATE		KTAKAHASHI	2016/03/18
0 PLACES		± 0.3		DRAFT WHERE APPLICABLE MUST REMAIN WITHIN DIMENSIONS		DRAWING SIZE		THIRD ANGLE PROJECTION		
A3		[Third Angle Projection Symbol]		PRODUCT CUSTOMER DRAWING						
SERIES		MATERIAL NUMBER		CUSTOMER		0.5 FFC CONN ZIF E/O BTM CONT TYPE ASSY				
505278		SEE SHEET 1		GENERAL		PRODUCT CUSTOMER DRAWING				
DOCUMENT NUMBER		DOC TYPE		DOC PART		SHEET NUMBER				
5052781001		PSD		000		2 OF 3				

注記 NOTES

1.使用材料 MATERIAL

ハウジング :液晶ポリマー ガラス充填、UL94V-0(ベージュ)  
 HOUSING LIQUID CRYSTAL POLYMER GLASS FILLED, UL94V-0(BEIGE)  
 アクチュエータ :ポリアミド ガラス充填、UL94V-0(黒)  
 ACTUATOR POLYAMIDE GLASS FILLED, UL94V-0(BLACK)  
 ターミナル :リン青銅(t=0.15)  
 TERMINAL PHOSPHOR BRONZE  
 金具 :リン青銅(t=0.15)  
 FITTING NAIL PHOSPHOR BRONZE

2.めっき仕様 PLATING

ターミナル TERMINAL  
 錫銀ビスマスめっき (1.0μm以上)  
 下地:ニッケルめっき (1.0μm以上)  
 TINSILVER BISMUTH PLATING (1.0 MICROMETER MINIMUM)  
 UNDERPLATE : NICKEL OVERALL (1.0 MICROMETER MINIMUM)  
 金具 FITTING NAIL  
 錫めっき(1.0μm以上)  
 下地:ニッケルめっき (1.0μm以上)  
 TIN PLATING (1.0 MICROMETER MIN.)  
 UNDER PLATING : NICKEL PLATING (1.0 MICROMETER MIN.)

3.エンボステープ梱包時は、アクチュエータが閉じた状態とする。  
 IN THE PACKAGE, ACTUATOR OF PART SHOULD BE CLOSED.

4. パターン剥離止め用金具  
 FITTING NAIL FOR PREVENTION OF PEELING OF P.C.B. PATTERN.

5. R0.3はFPC/FFC導体部にかからないこと。  
 R0.3 MUST NOT BE OVERLAPPED TO PATTERN OF FPC/FFC.

6.N:極数 N:CIRCUIT.

7.ELV及びRoHS適合品  
 ELV AND RoHS COMPLIANT

8.テールと金具を併せた平坦度は0.1以下とする。  
 TAILS AND NAILS COPLANALITY TO BE 0.1 MAX.

9. トレードマーク :Mプラス2文字の製造工場を示すアルファベットにて表示  
 但し,"J"はJAPANを"L"はMALAYSIAを示す。  
 (例MXJまたはMXL)

キャビティー番号 :1桁から2桁の数字にて表示  
 金型番号 :アルファベット1文字にて表示(例 A,B等)  
 TRADEMARK:DISPLAY BY M PLUS 2LETTERS OF ALPHABET WHICH MEAN THE MANUFACTURE.  
 BUT "J" MEANS JAPAN. "L" MEANS MALAYSIA (TO TRADE MARK)  
 (e.g. MXJ OR MXL)  
 AND BY 1 OR 2 DIGIT NUMBER (TO CAVITY NO.)  
 AND BY 1 LETTER OF ALPHABET (TO MOLD NO.)  
 (e.g. A,B etc)

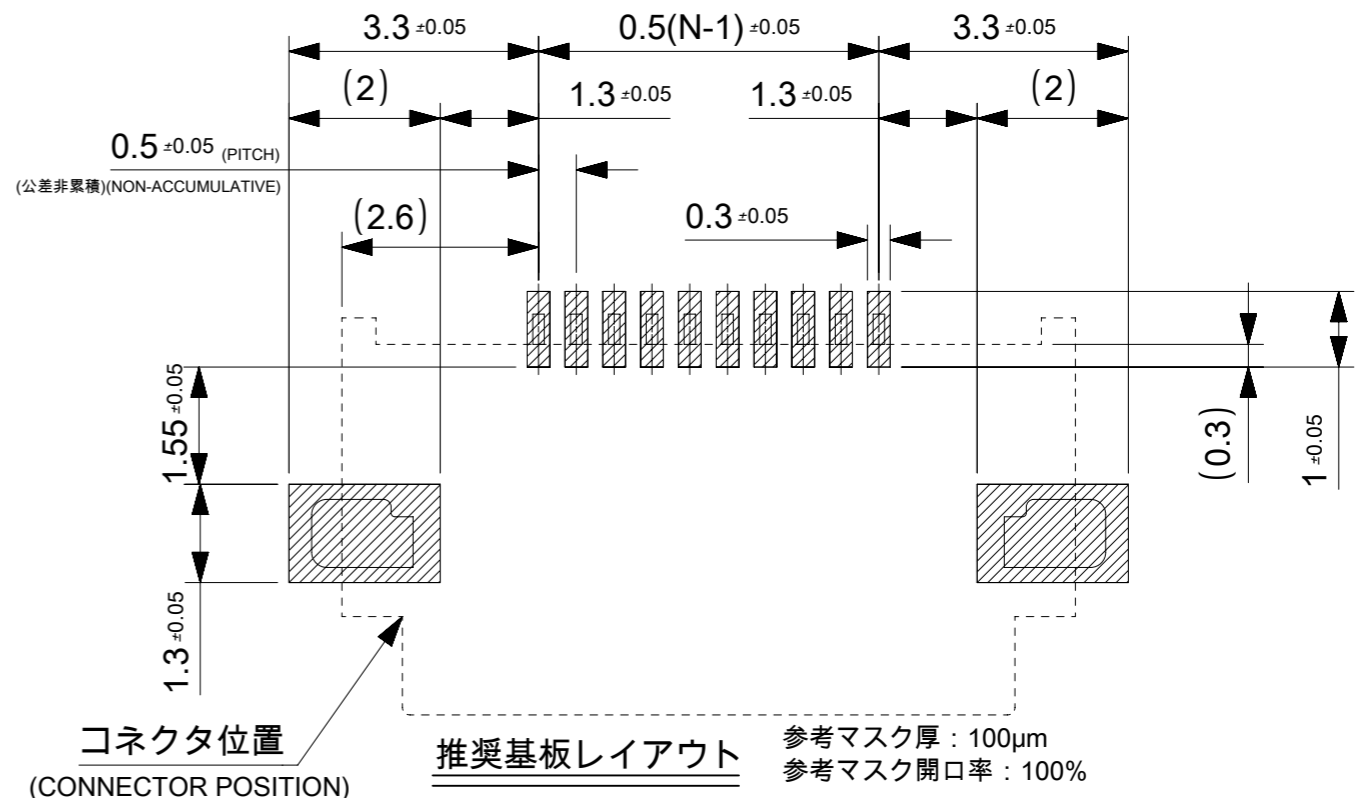

FPC/FFCについて ABOUT FFC

打ち抜き方向は導体側から補強板側を推奨します。  
 導体部については軟箔銅35μmまたは50μmを推奨します。  
 FFCに規定された定格温度がFFC単体前提である場合が御座います。  
 コネクタと組み合わせての実使用において、接着層が劣化するなどの信頼性を満足できないケースを回避するため、  
 実機での評価/確認をお願いいたします。

RECOMMENDED PUNCHING DIRECTION : FROM CONDUCTOR SIDE TO STIFFENER SIDE  
 RECOMMENDED CONDUCTOR SPEC : SOFT COPPER FOIL  
 RECOMMENDED CONDUCTOR THICKNESS : 35 MICROMETER OR 50 MICROMETER  
 NOTE: WHEN ACTUALLY USING IT WITH CONNECTOR, PLEASE DO THE EVALUATION AND THE CONFIRMATION WITH AN ACTUAL EQUIPMENT TO EVADE THE CASE WHERE RELIABILITY CANNOT BE FILLED (THE ADHESIVE LINE OF FFC IS DETERIORATED ETC.)

FPCについて ABOUT FPC

補強フィルム材質はポリイミドを推奨します。ベースフィルムは25μmを推奨します。  
 接着剤は熱硬化接着剤を推奨します。  
 尚、接着剤の接点部への付着は導通不良の原因になりますので、染み出しが無い様お願い致します。  
 RECOMMENDED MATERIAL/THICKNESS.  
 RECOMMENDED STIFFENER MATERIAL: POLYIMIDE  
 RECOMMENDED BASE FILM THICKNESS: 25 MICROMETER  
 RECOMMENDED ADHESIVE: THERMOSETTING ADHESIVE  
 NOTE: PLEASE PUT APPROPRIATE AMOUNT OF ADHESIVE ON ADHEREND BECAUSE THERE IS A POSSIBILITY THAT THE EXTRA ADHESIVE CAUSES THE DEFECT IN ELECTRICAL CONTINUITY.  
 THERE IS A POSSIBILITY THAT THE PRESCRIPT TEMPERATURE OF FFC IS SET TO SINGLE IT.

THIS DRAWING CONTAINS INFORMATION THAT IS PROPRIETARY TO MOLEX ELECTRONIC TECHNOLOGIES, LLC AND SHOULD NOT BE USED WITHOUT WRITTEN PERMISSION

REVISED	2017/06/09	2017/06/12	GENERAL TOLERANCES (UNLESS SPECIFIED)	DIMENSION UNITS	SCALE			
	2017/06/12	2017/06/12		MM	10:1			
	EC NO: 117930	DRWN: JASANUMA		CHK'D: YKOBAYASHI02	DRWN BY		DATE	0.5 FFC CONN ZIF E/O BTM CONT TYPE ASSY
		APP: TKUSUHARA01		APP: TKUSUHARA01	JASANUMA		2016/03/14	
D	REV	REV	4 PLACES ± 1.0 °	CHK'D BY	DATE	PRODUCT CUSTOMER DRAWING		
			3 PLACES ± 0.2	KTAKAHASHI	2016/03/18			
A	REV	REV	2 PLACES ± 0.2	APPR BY	DATE	SERIES		
			1 PLACE ± 0.25	NUKITA	2016/03/23		505278	
A	REV	REV	0 PLACES ± 0.3	DRAWING SIZE	THIRD ANGLE PROJECTION	MATERIAL NUMBER		
			DRAFT WHERE APPLICABLE MUST REMAIN WITHIN DIMENSIONS	A3		SEE SHEET 1		
RELEASE STATUS		P1	RELEASE DATE	12.06.2017	07:07:31	CUSTOMER		
9		8		7		GENERAL		
9		8		7		DOCUMENT NUMBER		
9		8		7		5052781001		
9		8		7		DOC TYPE		
9		8		7		PSD		
9		8		7		DOC PART		
9		8		7		000		
9		8		7		SHEET NUMBER		
9		8		7		3 OF 3		

引き出し方向

PULL OUT  
DIRECTION

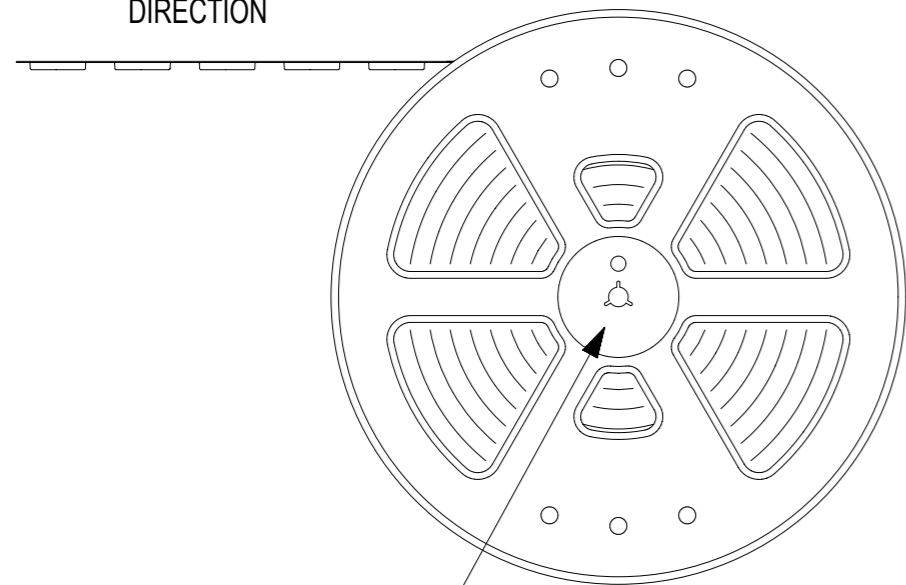

"E"

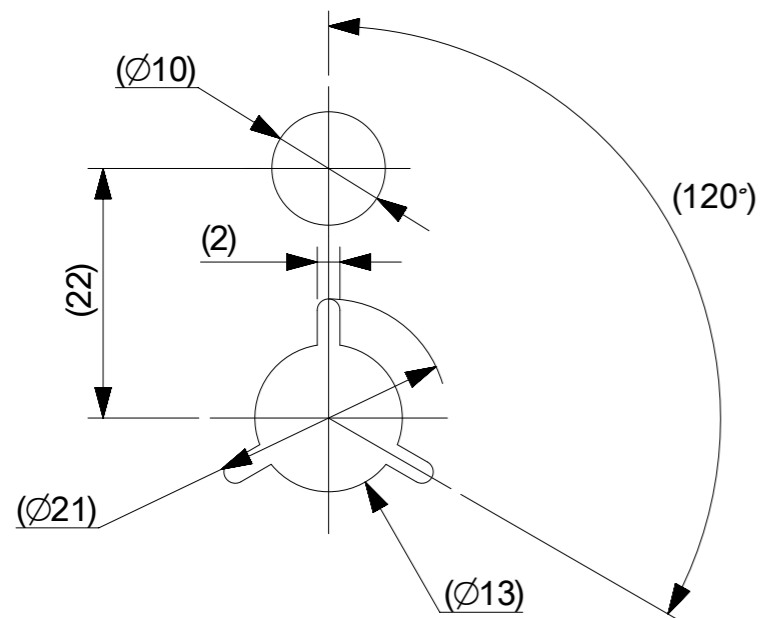
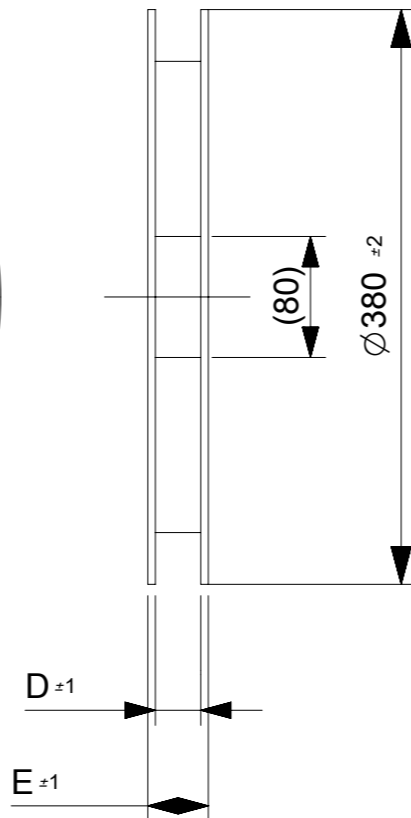

DETAIL "E"

NOTES

- 梱包数量 : 3000個 / リール  
NUMBER OF CONNECTORS : 3000 PCS/REEL.
- リードテープ長さ  
LEAD TAPE LENGTH

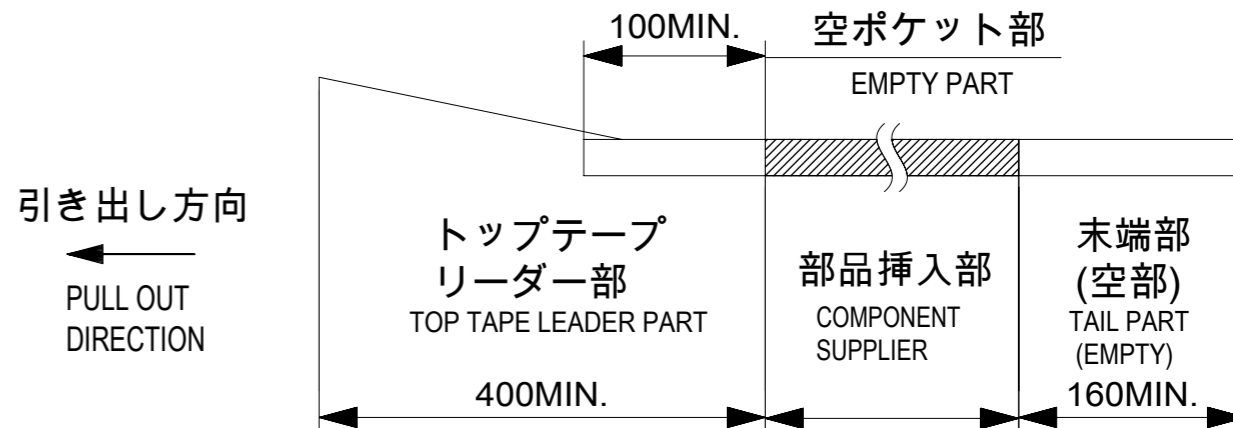

- カバーテープの剥離強度については、IEC60286-3に準拠。  
COVER TAPE PEEL FORCE IS DEFINED BY IEC 60286-3.
- 製品詳細寸法については、図面 5052781000/1001を参照下さい。  
FOR DIMENSIONS OF PRODUCT, REFER TO 5052781000/1001.
- 材料 MATERIAL  
キャリアテープ : ポリスチレン  
CARRIER TAPE : POLYSTYRENE  
トップテープ : ポリエチレンテレフタレート、ポリエチレン  
TOP TAPE : POLYETHYLENE TEREPHTHALATE, POLYETHYLENE  
リール : ポリスチレン<リサイクル材を含む>  
REEL : POLYSTYRENE <RECYCLE MATERIAL CONTAINED >
- ELV及びRoHS適合品 ELV AND RoHS COMPLIANT.

THIS DRAWING CONTAINS INFORMATION THAT IS PROPRIETARY TO MOLEX ELECTRONIC TECHNOLOGIES, LLC AND SHOULD NOT BE USED WITHOUT WRITTEN PERMISSION

EC NO: 106679 DRWN: YMIZUNO02 CHK'D: KTAKAHASHI APPR: TKUSUHARA01	2016/07/14 2016/07/28 2016/07/29	GENERAL TOLERANCES (UNLESS SPECIFIED) ANGULAR TOL $\pm 1.0^\circ$	DIMENSION UNITS: MM SCALE: 2:1	<b>molex</b> 0.5 FFC CONN ZIF E/O EMBOSSED TAPE PKG			
	4 PLACES $\pm 0.03$ 3 PLACES $\pm 0.03$ 2 PLACES $\pm 0.05$ 1 PLACE $\pm 0.1$ 0 PLACES $\pm 0.2$	DRWN BY: FSATO DATE: 2015/02/09 CHK'D BY: KTAKAHASHI DATE: 2015/02/12 APPR BY: YNOGAWA DATE: 2015/02/12	PRODUCT CUSTOMER DRAWING				
	DRAFT WHERE APPLICABLE MUST REMAIN WITHIN DIMENSIONS	DRAWING SIZE: A3 THIRD ANGLE PROJECTION	SERIES: 505278 MATERIAL NUMBER: SEE CHART CUSTOMER: GENERAL	DOCUMENT NUMBER: 5052780000 DOC TYPE: PSD DOC PART: 000 SHEET NUMBER: 1 OF 2			

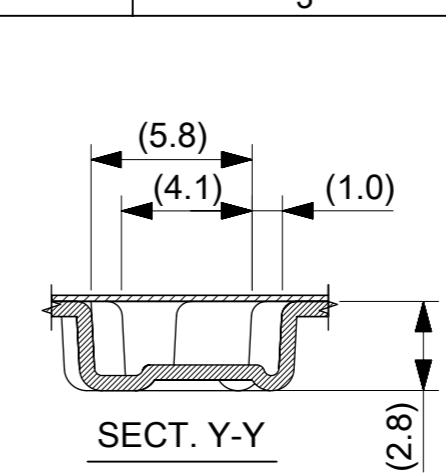
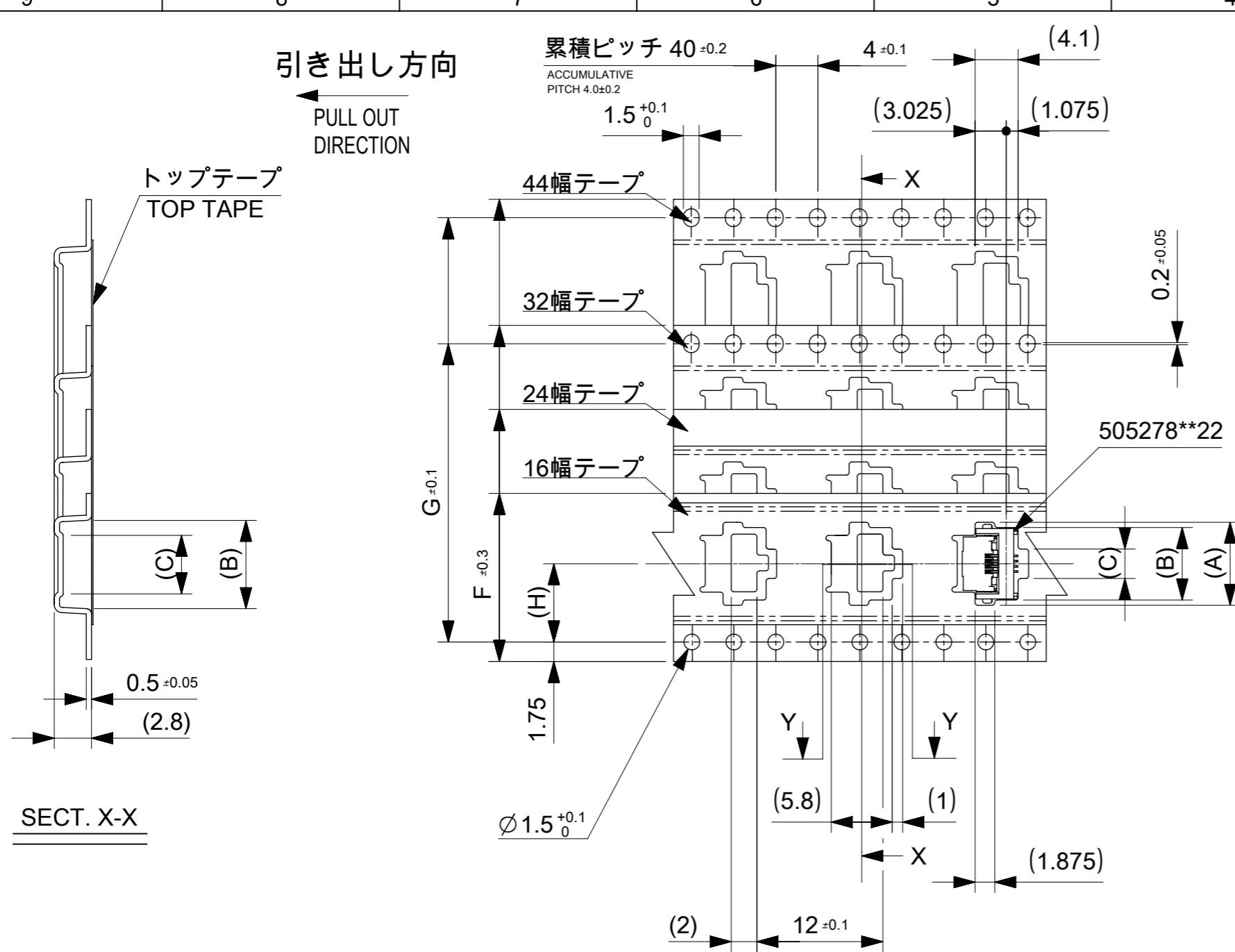

CONNECTOR SERIES NO.505278\*\*22

H	G	F	E	D	C	B	A	EMBOSSED PACKAGE オーダー番号 ORDER NO.	Ckt
20.2	40.4	44	49.4	45.4	25.9	29.9	31	5052785033	50
					23.4	27.4	28.5	5052784533	45
					20.9	24.9	26	5052784033	40
					18.4	22.4	23.5	5052783533	35
					15.9	19.9	21	5052783033	30
14.2	28.4	32	37.4	33.4	14.9	18.9	20	5052782833	28
					13.9	17.9	19	5052782633	26
					12.9	16.9	18	5052782433	24
					11.9	15.9	17	5052782233	22
					10.9	14.9	16	5052782033	20
					10.4	14.4	15.5	5052781933	19
					9.9	13.9	15	5052781833	18
					9.4	13.4	14.5	5052781733	17
					8.9	12.9	14	5052781633	16
					8.4	12.4	13.5	5052781533	15
					7.9	11.9	13	5052781433	14
					7.4	11.4	12.5	5052781333	13
11.5	---	24	29.4	25.4	6.9	10.9	12	5052781233	12
					6.4	10.4	11.5	5052781133	11
					5.9	9.9	11	5052781033	10
					5.4	9.4	10.5	5052780933	9
					4.9	8.9	10	5052780833	8
					4.4	8.4	9.5	5052780733	7
					3.9	7.9	9	5052780633	6
					3.4	7.4	8.5	5052780533	5
7.5	---	16	21.4	17.4	2.9	6.9	8	5052780433	4

THIS DRAWING CONTAINS INFORMATION THAT IS PROPRIETARY TO MOLEX ELECTRONIC TECHNOLOGIES, LLC AND SHOULD NOT BE USED WITHOUT WRITTEN PERMISSION

EC NO: 106679 DRWN: YMIZUNO02 CHK'D: KTAKAHASHI APPR: TKUSUHARA01	2016/07/14	GENERAL TOLERANCES (UNLESS SPECIFIED)		DIMENSION UNITS	SCALE	
	2016/07/28	ANGULAR TOL ± 1.0 °		MM	2:1	
	2016/07/29	4 PLACES ± 0.03	3 PLACES ± 0.03	DRWN BY	DATE	
		2 PLACES ± 0.05	1 PLACE ± 0.1	FSATO	2015/02/09	
		0 PLACES ± 0.2	DRAFT WHERE APPLICABLE MUST REMAIN WITHIN DIMENSIONS	CHK'D BY	DATE	0.5 FFC CONN ZIF E/O EMBOSSED TAPE PKG
			YNOGAWA	2015/02/12		
			APPR BY	DATE		
			DRAWING SIZE	THIRD ANGLE PROJECTION		
				A3		PRODUCT CUSTOMER DRAWING
						SERIES: 505278 MATERIAL NUMBER: SEE CHART CUSTOMER: GENERAL
						DOCUMENT NUMBER: 5052780000 DOC TYPE: PSD DOC PART: 000 SHEET NUMBER: 2 OF 2