

- NOTES:
1. MATERIAL: SEE CHART
 2. FINISH: SEE CHART
 3. PRODUCT SPECIFICATION: PS-5556-001, PS-5556-002, PS-5556-003
 4. PACKAGING SPECIFICATION: PK-5558-001 FOR CHAIN
PK-5556-003 FOR LOOSE
 5. MATES WITH TERMINAL: 5556 SERIES.
 6. APPLICABLE HOUSING: 5559, 30068, 42475 SERIES.
 7. THE NUMBER OF SERRATIONS TO BE ONE FOR WIRE RANGE #22-28.
 8. WHEN TERMINALS ARE INSTALLED IN THE HOUSING THE WIRES ARE TO BE DRESSED IN SUCH A MANNER TO ALLOW THE TERMINALS TO FLOAT FREELY IN THE POCKET.
 9. THIS TERMINAL IS DESIGNED FOR SINGLE WIRE CRIMPING.
 10. PART CONFORMS TO CLASS "B" REQUIREMENTS OF COSMATIC SPECIFICATION PS-45499-002.
 11. TEXT ON PART IS FOR REFERENCE ONLY. TEXT AND TEXT LOCATION MAY VARY DEPENDING ON PART NUMBER AND/OR TOOL.

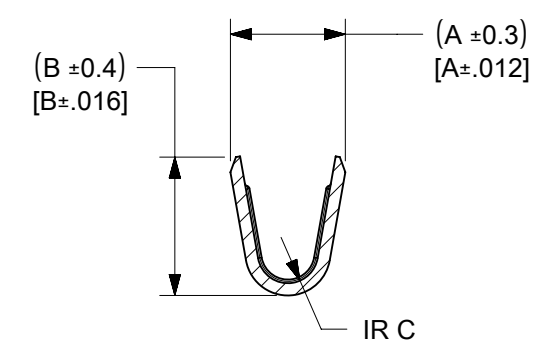

SECTION G-G

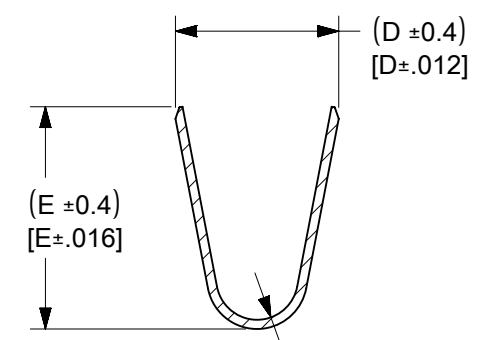
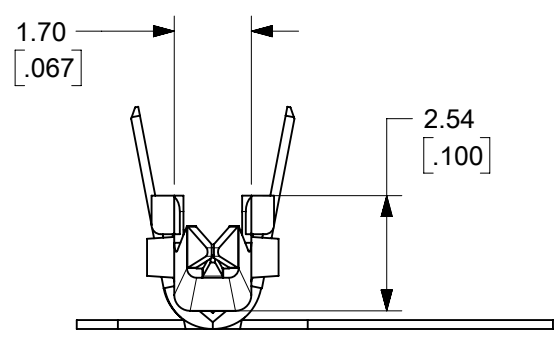

SECTION H-H

FUNCTIONAL SYMBOLS										THIS DRAWING CONTAINS INFORMATION THAT IS PROPRIETARY TO MOLEX ELECTRONIC TECHNOLOGIES, LLC AND SHOULD NOT BE USED WITHOUT WRITTEN PERMISSION									
DIMENSION UNITS					SCALE					CURRENT REV DESC:									
mm/inch					NTS					EC NO: 660823									
GENERAL TOLERANCES (UNLESS SPECIFIED)										DRWN: VIJAYS4 2021/04/06									
4 PLACES ±					MM					INCH					CHK'D: YXZHENG 2021/04/14				
3 PLACES ±					± 0.01					APPR: YXZHENG 2021/04/14					INITIAL REVISION:				
2 PLACES ±					± 0.25					± 0.01					DRWN: H.HIRAMOTO 1991/03/12				
1 PLACE ±					±					±					APPR: FSMITH 2010/04/09				
0 PLACES ±					±					±					ANGULAR TOL ± 3.0°				
DIVISIONAL SYMBOLS										DRAFT WHERE APPLICABLE MUST REMAIN WITHIN DIMENSIONS									
THIRD ANGLE PROJECTION					DRAWING					SERIES					MATERIAL NUMBER				
B-SIZE					5558					SEE SHEET 2					CUSTOMER				
GENERAL MARKET					1 OF 2					SD-5558XXXX					PSD 001 L2				

PLATING		MATERIAL	F	E	D	C	B	A	INS.RANGE	WIRE AWG RANGE		EDP NO.	ENG. NO.	FORM
REFLOWED MATTE TIN 0.00090/(.000035) MIN. (PREPLATE) (FINISH IS BRIGHT IN APPEARANCE, THICKNESS AS APPLIED PRIOR TO REFLOW)	PHOSPHOR BRONZE	(0.9) .035	(4.5) .177	(3.6) .142	(0.6) .024	(2.7) .106	(2.3) .091	∅ (3.1) .122 MAX	16	N/A	39-00-0084	5558 PBT3L	LOOSE	
										20+20	39-00-0083	5558 PBT3	CHAIN	
										20+22				
		(0.6) .024	(2.3) .091	(2.3) .091	(0.4) .016	(1.65) .065	(1.8) .071	∅ (0.9 - 1.8) .035 - .071	22-28	N/A	39-00-0068	5558 PBT2L	LOOSE	
										N/A	39-00-0067	5558 PBT2	CHAIN	
		(0.9) .035	(4.5) .177	(3.6) .142	(0.5) .020	(2.3) .091	(1.9) .075	∅ (1.3 - 3.1) .051 - .122	18-24	N/A	39-00-0062	5558 PBTL	LOOSE	
22+22	39-00-0061									5558 PBT	CHAIN			
REFLOWED MATTE TIN 0.00090/(.000035) MIN OVER COPPER 0.00050/(.000020) MIN. (PREPLATE) (FINISH IS BRIGHT IN APPEARANCE, THICKNESS AS APPLIED PRIOR TO REFLOW)	BRASS	(0.9) .035	(4.5) .177	(3.6) .142	(0.6) .024	(2.7) .106	(2.3) .091	∅ (3.1) .122 MAX	16	N/A	39-00-0082	5558 T3L	LOOSE	
										20+20	39-00-0081	5558 T3	CHAIN	
										20+22				
		(0.6) .024	(2.3) .091	(2.3) .091	(0.4) .016	(1.65) .065	(1.8) .071	∅ (0.9 - 1.8) .035 - .071	22-28	N/A	39-00-0049	5558 T2L	LOOSE	
										N/A	39-00-0048	5558 T2	CHAIN	
		(0.9) .035	(4.5) .177	(3.6) .142	(0.5) .020	(2.3) .091	(1.9) .075	∅ (1.3 - 3.1) .051 - .122	18-24	N/A	39-00-0041	5558 TL	LOOSE	
22+22	39-00-0040									5558 T	CHAIN			

FUNCTIONAL SYMBOLS										THIS DRAWING CONTAINS INFORMATION THAT IS PROPRIETARY TO MOLEX ELECTRONIC TECHNOLOGIES, LLC AND SHOULD NOT BE USED WITHOUT WRITTEN PERMISSION									
DIMENSION UNITS					SCALE					CURRENT REV DESC:									
mm/inch					NTS					EC NO: 660823									
GENERAL TOLERANCES (UNLESS SPECIFIED)										DRWN: VIJAYS4 2021/04/06									
4 PLACES ±					MM INCH					CHK'D: YXZHENG 2021/04/14									
3 PLACES ±					± 0.01					APPR: YXZHENG 2021/04/14									
2 PLACES ±					0.25 ± 0.01					INITIAL REVISION:									
1 PLACE ±					0.25 ±					DRWN: H.HIRAMOTO 1991/03/12									
0 PLACES ±					±					APPR: FSMITH 2010/04/09									
ANGULAR TOL ± 3.0°										DOCUMENT NUMBER									
DRAFT WHERE APPLICABLE MUST REMAIN WITHIN DIMENSIONS					THIRD ANGLE PROJECTION					DRAWING					SERIES				
					B-SIZE					5558					MATERIAL NUMBER				
										SEE TABLE					CUSTOMER				
															GENERAL MARKET				
															SHEET NUMBER				
															2 OF 2				

molex

MINI-FIT JR
OVERALL TIN MALE CRIMP TERMINAL

PRODUCT CUSTOMER DRAWING

DOCUMENT NUMBER: SD-5558XXXX | DOC TYPE: PSD | DOC PART: 001 | REVISION: L2

10 9 8 7 6 5 4 3 2 1

REFLOWED MATTE TIN 0.00090/(.000035)
MIN. (PREPLATE) (FINISH IS BRIGHT IN APPEARANCE,
THICKNESS AS APPLIED PRIOR TO REFLOW)

PHOSPHOR
BRONZE

(0.9) .035	(4.5) .177	(3.6) .142	(0.6) .024	(2.7) .106	(2.3) .091	∅ (3.1) .122 MAX.	# 16
(0.6) .024	(2.3) .091	(2.3) .091	(0.4) .016	(1.65) .065	(1.8) .071	∅ (0.9-1.8) .035-.071	#22-28
(0.9) .035	(4.5) .177	(3.6) .142	(0.5) .020	(2.3) .091	(1.9) .075	∅ (1.3-3.1) .051-.122	#18-24

39-00-0084	5558 PBT3L	LOOSE
↑ -0083	↑ PBT3	CHAIN
-0068	PBT2L	LOOSE
-0067	PBT2	CHAIN
-0062	PBTL	LOOSE
-0061	PBT	CHAIN

REFLOWED MATTE TIN 0.00090/(.000035)
MIN OVER COPPER 0.00050/(.000020)
MIN. (PREPLATE) (FINISH IS BRIGHT IN APPEARANCE,
THICKNESS AS APPLIED PRIOR TO REFLOW)

BRASS

(0.9) .035	(4.5) .177	(3.6) .142	(0.6) .024	(2.7) .106	(2.3) .091	∅ (3.1) .122 MAX.	# 16
(0.6) .024	(2.3) .091	(2.3) .091	(0.4) .016	(1.65) .065	(1.8) .071	∅ (0.9-1.8) .035-.071	#22-28
(0.9) .035	(4.5) .177	(3.6) .142	(0.5) .020	(2.3) .091	(1.9) .075	∅ (1.3-3.1) .051-.122	#18-24

↑ -0082	T3L	LOOSE
-0081	T3	CHAIN
-0049	T2L	LOOSE
-0048	T2	CHAIN
↓ -0041	↓ TL	LOOSE
39-00-0040	5558 T	CHAIN

PLATING MATERIAL F E D C B A INS. RANGE WIRE RANGE EDP NO. ENG. NO. FORM

SEE SHEET 1
EC NO: UCP2017-1893
DRAWN: GSLAFTER 2017/02/28
CHKD: JBELL 2017/03/14
APPR: FSMITH 2017/07/31

QUALITY SYMBOLS
▽=0
▽=0
▽=0

GENERAL TOLERANCES (UNLESS SPECIFIED)

	mm	INCH
4 PLACES	± ---	± ---
3 PLACES	± ---	± .010
2 PLACES	± .25	± .010
1 PLACE	± .25	± ---
ANGULAR ± 3 °		

DRAFT WHERE APPLICABLE
MUST REMAIN
WITHIN DIMENSIONS

DIMENSION STYLE
MM/IN

DRAWN BY DATE
H.HIRAMOTO 1991/03/12

CHECKED BY DATE
S.KUNISHI 1998/07/07

APPROVED BY DATE
FSMITH 2010/04/09

MATERIAL NO.
SEE CHART

SIZE
B

SCALE
DESIGN UNITS
METRIC

THIRD ANGLE PROJECTION

MINI-FIT JR
OVERALL TIN
MALE CRIMP TERMINAL

molex MOLEX INCORPORATED

DOCUMENT NO.
SD-5558****

SHEET NO.
2 OF 2

THIS DRAWING CONTAINS INFORMATION THAT IS PROPRIETARY TO MOLEX INCORPORATED AND SHOULD NOT BE USED WITHOUT WRITTEN PERMISSION