



The following document contains information on Cypress products. Although the document is marked with the name “Spansion” and “Fujitsu”, the company that originally developed the specification, Cypress will continue to offer these products to new and existing customers.

Continuity of Specifications

There is no change to this document as a result of offering the device as a Cypress product. Any changes that have been made are the result of normal document improvements and are noted in the document history page, where supported. Future revisions will occur when appropriate, and changes will be noted in a document history page.

Continuity of Ordering Part Numbers

Cypress continues to support existing part numbers. To order these products, please use only the Ordering Part Numbers listed in this document.

For More Information

Please contact your local sales office for additional information about Cypress products and solutions.

About Cypress

Cypress (NASDAQ: CY) delivers high-performance, high-quality solutions at the heart of today’s most advanced embedded systems, from automotive, industrial and networking platforms to highly interactive consumer and mobile devices. With a broad, differentiated product portfolio that includes NOR flash memories, F-RAM™ and SRAM, Traveo™ microcontrollers, the industry’s only PSoC® programmable system-on-chip solutions, analog and PMIC Power Management ICs, CapSense® capacitive touch-sensing controllers, and Wireless BLE Bluetooth® Low-Energy and USB connectivity solutions, Cypress is committed to providing its customers worldwide with consistent innovation, best-in-class support and exceptional system value.

ASSP (for Mobile Terminals)

Power Management IC for Mobile Terminals 3ch DC/DC Converter + 4ch LDO

MB39C316

■ DESCRIPTION

The MB39C316 is equipped with the 3 ch DC/DC converter and the 4 ch linear regulator (LDO), and is the power supply LSI for mobile terminals which operate in the range of power supply voltage with 1-cell Li-ion power by 1ch high efficiency voltage step-up/down DC/DC.

The MB39C316 contains the 2ch synchronous rectification DC/DC converter with current mode system and the 1ch voltage step-up/down DC/DC converter. Detecting load current by each DC/DC converter alternates the Normal mode (PWM) with the ECO mode (PFM) automatically.

MB39C316 has the built-in 4ch LDO which is suitable to supply voltage to the system block and the built-in 1ch LDO which generates stable internal reference voltage.

It is possible to control a notice of internal condition, the power supply and reset in order to support the communication interface which is compliant with the I²C bus standard.

■ FEATURES

- Input voltage range : 2.7 V to 5.5 V
- Step-down regulators : 2 channels
- Step-up/down regulator : 1 channel
- Linear regulator (LDO) : 4 channels
- Possible to select output voltage : LDO3 1.2 V/1.3 V (register setting)
- On/Off control of LDO and DC/DC converter by external signals and register settings
- Compliant with I²C bus standard (Max 400 kbps)
- Possible to output the 32.768 kHz clock by connecting crystal oscillator
- Protection function: Over current protection (OCP), Output short circuit protection (SCP),
Under voltage lock out protection (UVLO), Over temperature protection (OTP)
- Package : 49 pin, WL-CSP (3.14 mm × 3.11 mm × 0.8 mm)

■ APPLICATIONS

- Mobile WiMAX terminals
- Other mobile terminals etc.

■ PIN ASSIGNMENT

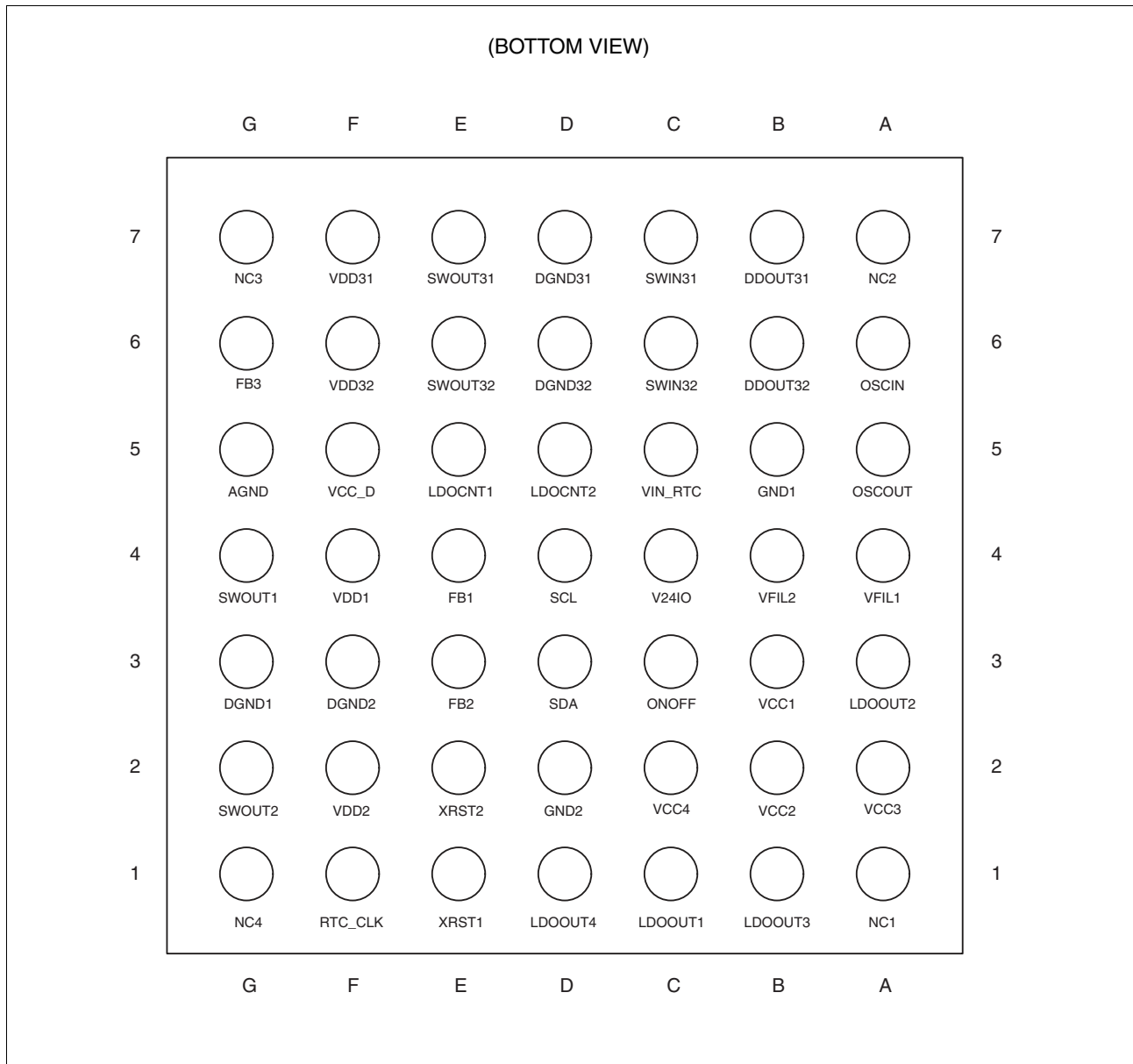

■ PIN DISCRIPTIONS

Block	Pin No.	Pin name	I/O	Descriptions
External power supply	B3	VCC1	I	Power supply input, Power supply input pin for LDO2, LDO3 control
	B2	VCC2	I	Power supply input pin for LDO2 power
	A2	VCC3	I	Power supply input pin for LDO3 power
	C2	VCC4	I	Power supply input pin for LDO1, LDO4 control/power
	F5	VCC_D	I	Power supply input pin for DC/DC converter control
	F4	VDD1	I	Power supply input pin for DC/DC1 converter power
	F2	VDD2	I	Power supply input pin for DC/DC2 converter power
	F7	VDD31	I	Power supply input pin 1 for DC/DC3 converter power
	F6	VDD32	I	Power supply input pin 2 for DC/DC3 converter power
	C5	VIN_RTC	I	Power supply input pin for RTC
Constant voltage power supply	E5	LDOCNT1	I	LDO output control input pin 1
	D5	LDOCNT2	I	LDO output control input pin 2
	D1	LDOOUT4	O	LDO4 output pin (+ 2.9 V)
	B1	LDOOUT3	O	LDO3 output pin (+ 1.2 V/1.3 V)
	C1	LDOOUT1	O	LDO1 output pin (+ 2.9 V)
	A3	LDOOUT2	O	LDO2 output pin (+ 1.2 V)
	G4	SWOUT1	O	DC/DC1 converter inductance connection output pin
	E4	FB1	I	DC/DC1 converter output voltage feedback input pin (1.2 V)
	G2	SWOUT2	O	DC/DC2 converter inductance connection output pin
	E3	FB2	I	DC/DC2 converter output voltage feedback input pin (1.8 V)
	E7	SWOUT31	—	DC/DC3 converter inductance connection pin 1
	E6	SWOUT32	—	DC/DC3 converter inductance connection pin 2
	C7	SWIN31	—	DC/DC3 converter inductance connection pin 1
	C6	SWIN32	—	DC/DC3 converter inductance connection pin 2
	B7	DDOUT31	O	DC/DC3 converter output pin 1
B6	DDOUT32	O	DC/DC3 converter output pin 2	
G6	FB3	I	DC/DC3 converter output voltage feedback input pin (3.3 V)	
I ² C interface	D4	SCL	I	I ² C interface clock input pin
	D3	SDA	I/O	I ² C interface data I/O pin
RTC	A6	OSCIN	I	Input pin for crystal oscillator connection
	A5	OSCOU	O	Output pin for crystal oscillator connection
	F1	RTC_CLK	O	32.768 kHz Clock output pin
Start/Stop	C3	ONOFF	I	Enable pin for the MB39C316
	E1	XRST1	O	Reset output pin 1
	E2	XRST2	O	Reset output pin 2
Reference voltage	C4	V24IO	O	Power supply output pin for internal 2.4 V I/O
	A4	VFIL1	O	Reference voltage output pin 1 (0.47 μF connected)
	B4	VFIL2	O	Reference voltage output pin 2 (0.47 μF connected)

(Continued)

MB39C316

(Continued)

Block	Pin No.	Pin name	I/O	Descriptions
TEST	A1	NC1	—	Pin for TEST (Set to Non Connect. Prohibited to connect to others.)
	A7	NC2	—	Pin for TEST (Set to Non Connect. Prohibited to connect to others.)
	G7	NC3	—	Pin for TEST (Set to Non Connect. Prohibited to connect to others.)
	G1	NC4	—	Pin for TEST (Set to Non Connect. Prohibited to connect to others.)
GND	B5	GND1	—	Ground pin (COMMON, RTC)
	D2	GND2	—	Ground pin (LDO, INPUT_IF, OUTPUT_IF)
	G5	AGND	—	Ground pin (DC/DC converter control block)
	G3	DGND1	—	DC/DC1 converter ground pin
	F3	DGND2	—	DC/DC2 converter ground pin
	D7	DGND31	—	DC/DC3 converter ground pin 1
	D6	DGND32	—	DC/DC3 converter ground pin 2

■ BLOCK DIAGRAM

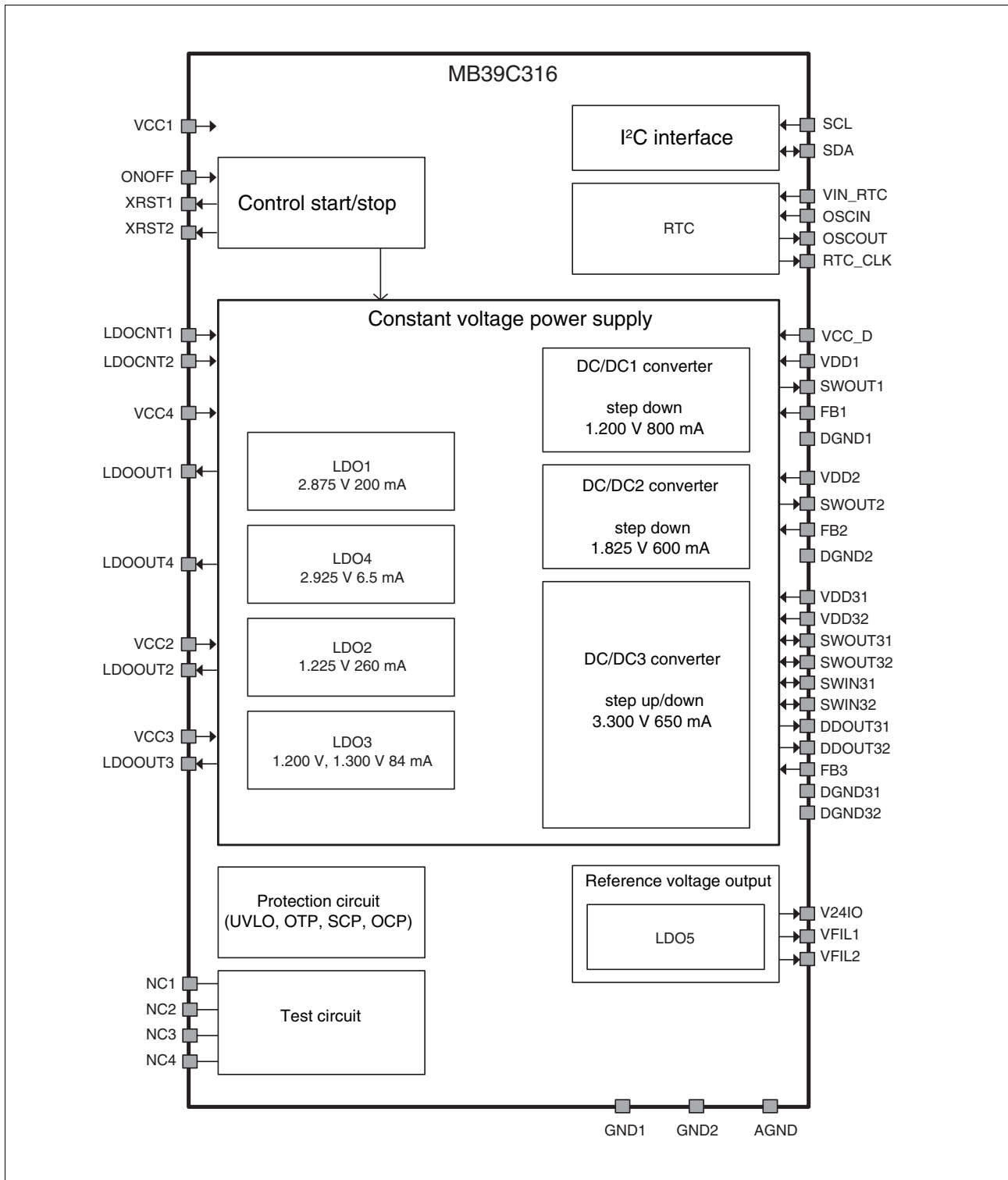

■ ABSOLUTE MAXIMUM RATINGS

Parameter	Symbol	Condition	Rating		Unit
			Min	Max	
Power supply voltage	Vmax1	VCC1, VCC_D, VDD1, VDD2, VDD31, VDD32	- 0.3	+ 6.0	V
	Vmax2	VCC2, VCC3	- 0.3	+ 6.0	V
	Vmax3	VCC4	- 0.3	+ 6.0	V
	Vmax4	VIN_RTC	- 0.3	+ 3.6	V
Input voltage	Vinmax1	LDOCNT1, LDOCNT2, SCL, SDA	- 0.3	Vvcc3 + 0.3	V
	Vinmax2	ONOFF, FB1, FB2, FB3	- 0.3	Vvcc1 + 0.3	V
	Vinmax3	OSCIN	- 0.3	Vrtc	V
Storage temperature range	Tstg	—	- 55	+ 125	°C
ESD withstand voltage	Vesdh	Human Body Model (100 pF, 1.5 kΩ)	- 1000	+ 1000	V
	Vesdm	Machine Model (200 pF, 0 Ω)	- 100	+ 100	V
latch-up withstand voltage	Vlatchup	EIA/JEDEC Standard	- 150	+ 150	mA

WARNING: Semiconductor devices can be permanently damaged by application of stress (voltage, current, temperature, etc.) in excess of absolute maximum ratings. Do not exceed these ratings.

■ RECOMMENDED OPERATION CONDITIONS

Parameter	Symbol	Condition	Value			Unit
			Min	Typ	Max	
Power supply voltage	Vvcc1	VCC1, VCC_D, VDD1, VDD2, VDD31, VDD32	2.7	3.3	5.5	V
	Vvcc2	VCC2, VCC3	1.75	—	1.90	V
	Vvcc3	VCC4	3.2	—	5.5	V
	Vrtc	VIN_RTC	2.325	—	2.475	V
Input voltage	Vlvcc1	ONOFF	0.0	—	Vvcc1	V
	Vlvcc3	LDOCNT1, LDOCNT2, SCL, SDA	0.0	—	Vvcc3	V
	Vlidd1	FB1	0.0	—	Voutdd1	V
	Vlidd2	FB2	0.0	—	Voutdd2	V
	Vlidd3	FB3	0.0	—	Voutdd3	V
	Vlrtc	OSCIN	0.0	—	Vrtc	V
Operating temperature range	Ta	—	- 30	—	+ 85	°C

WARNING: The recommended operating conditions are required in order to ensure the normal operation of the semiconductor device. All of the device's electrical characteristics are warranted when the device is operated within these ranges.

Always use semiconductor devices within their recommended operating condition ranges. Operation outside these ranges may adversely affect reliability and could result in device failure. No warranty is made with respect to uses, operating conditions, or combinations not represented on the data sheet. Users considering application outside the listed conditions are advised to contact their representatives beforehand.

■ ELECTRICAL CHARACTERISTICS

1. DC characteristics

(Ta = -30 °C to +85 °C, Vvcc1 = 2.7 V to 5.5 V, Vvcc3 = 3.2 V to 5.5 V,
Vvcc2 = 1.75 V to 1.90 V, Vrtc = 2.325 V to 2.475 V)

Parameter	Symbol	Condition	Value			Unit			
			Min	Typ	Max				
LDO1	Output voltage	Voutld1	Iout = 0 to Iomax		2.800	2.875	3.000	V	
	Maximum output current	Ioutld1	—		200	—	—	mA	
	Input stability	Vlined1	Iout = -10 mA		—	5	—	mV	
	Load stability	Vloadld1	Iout = 0 to Iomax		—	20	—	mV	
	Ripple removal ratio	RR1kld1	Vinput = 0.2 Vpp, Vvcc1 = 3.3 V, Iout = Iomax/2	f = 1 kHz		—	60	—	dB
		RR10kld1		f = 10 kHz		—	40	—	dB
	Output noise voltage	Vnoiseld1	f = 10 Hz to 100 kHz, Iout = 10 mA to Iomax		—	30	45	μVrms	
	Rise time	Trld1	Vvcc1 = 3.3 V, Iout = 0 mA, Vout = 90%		—	200	—	μs	
Fall time	Tfld1	Vvcc1 = 3.3 V, Iout = 0 mA, Vout = 10%		—	70	—	μs		
LDO2	Output voltage	Voutld2	Iout = 0 to Iomax		1.150	1.225	1.300	V	
	Maximum output current	Ioutld2	—		260	—	—	mA	
	Input stability	Vlined2	Iout = -10mA		—	5	—	mV	
	Load stability	Vloadld2	Iout = 0 to Iomax		—	25	—	mV	
	Ripple removal ratio	RR1kld2	Vinput = 0.2 Vpp, Vvcc1, Iout = 1 mA to Iomax	f = 1 kHz		—	60	—	dB
		RR10kld2		f = 10 kHz		—	40	—	dB
	Output noise voltage	Vnoiseld2	f = 10 Hz to 100 kHz, Iout = 10 mA to Iomax		—	30	45	μVrms	
	Rise time	Trld2	Vvcc1, Iout = 0 mA, Vout = 90%		—	70	—	μs	
Fall time	Tfld2	Vvcc1, Iout = 0 mA, Vout = 10%		—	150	—	μs		

(Continued)

MB39C316

Parameter		Symbol	Condition		Value			Unit
					Min	Typ	Max	
LDO3	Output voltage	Voutld3	Iout = 0 to Iomax, VSEL_SYN = "0" (register 02H[0])		1.100	1.200	1.300	V
			Iout = 0 to Iomax, VSEL_SYN = "1" (register 02H[0])		1.200	1.300	1.400	V
	Maximum output current	Ioutld3	—		84	—	—	mA
	Input stability	Vlineld3	Iout = - 10 mA		—	5	—	mV
	Load stability	Vloadld3	Iout = 0 to Iomax		—	20	—	mV
	Ripple removal ratio	RR1kld3	Vinput = 0.2 Vpp, Vvcc1, Iout = 1mA to Iomax	f = 1 kHz	—	60	—	dB
		RR10kld3		f = 10 kHz	—	40	—	dB
	Output noise voltage	Vnoiseld3	f = 10 Hz to 100 kHz, Iout = 10 mA to Iomax		—	30	40	μVrms
	Rise time	Trld3	Vvcc1, Iout = 0 mA, Vout = 90%		—	60	—	μs
Fall time	Tfld3	Vvcc1, Iout = 0 mA, Vout = 10%		—	150	—	μs	
LDO4	Output voltage	Voutld4	Iout = 0 to Iomax		2.850	2.925	3.000	V
	Maximum output current	Ioutld4	—		6.5	—	—	mA
	Input stability	Vlineld4	Iout = - 6.5 mA		—	5	—	mV
	Load stability	Vloadld4	Iout = 0 to Iomax		—	5	—	mV
	Ripple removal ratio	RR1kld4	Vinput = 0.2 Vpp, Vvcc1 = Vvcc3 = 3.3 V, Iout = 1 mA to Iomax	f = 1 kHz	—	60	—	dB
		RR10kld4		f = 10 kHz	—	40	—	dB
	Output noise voltage	Vnoiseld4	f = 10 Hz to 100 kHz, Iout = 1 mA to Iomax		—	30	40	μVrms
	Rise time	Trld4	Vvcc1 = Vvcc3 = 3.3 V, Iout = 0 mA, Vout = 90%		—	130	—	μs
Fall time	Tfld4	Vvcc1 = Vvcc3 = 3.3 V, Iout = 0 mA, Vout = 10%		—	70	—	μs	

(Continued)

Parameter		Symbol	Condition	Value			Unit
				Min	Typ	Max	
DC/DC1 converter	Output voltage	Voutdd1	Iout = 0 to Iomax	1.100	1.200	1.300	V
	Maximum output current	Ioutdd1	—	800	—	—	mA
	Output ripple voltage	Vrpldd11	Iout = 0 to Iomax	—	15	—	mV
	Input stability	Vlinedd1	Vvcc1 = 2.7 V to 5.5 V	—	10	—	mV
	Load stability	Vloaddd1	Iout = -1 mA to Iomax	—	—	20	mV
	Oscillation frequency	Fdd1	PWM mode	—	1.7	—	MHz
	Efficiency	η dd1	Vvcc1 = 3.3 V, Iout = -200 mA	75	85	—	%
	Rise time	Trdd1	Vvcc1 = 3.3 V, Iout = 0 mA	—	50	—	μ s
	Fall time	Tfdd1	Vvcc1 = 3.3 V, Iout = 0 mA	—	200	—	μ s
DC/DC2 converter	Output voltage	Voutdd2	Iout = 0 to Iomax	1.750	1.825	1.900	V
	Maximum output current	Ioutdd2	—	600	—	—	mA
	Output ripple voltage	Vrpldd21	Iout = 0 to Iomax	—	15	—	mV
	Input stability	Vlinedd2	Vvcc1 = 2.7 V to 5.5 V	—	10	—	mV
	Load stability	Vloaddd2	Iout = -1 mA to Iomax	—	—	20	mV
	Oscillation frequency	Fdd2	PWM mode	—	1.7	—	MHz
	efficiency	η dd2	Vvcc1 = 3.3 V, Iout = -200 mA	80	90	—	%
	Rise time	Trdd2	Vvcc1 = 3.3 V, Iout = 0 mA	—	50	—	μ s
	Fall time	Tfdd2	Vvcc1 = 3.3 V, Iout = 0 mA	—	200	—	μ s
DC/DC3 converter	Output voltage	Voutdd3	Iout = 0 to Iomax	3.200	3.300	3.400	V
	Maximum output current	Ioutdd3	—	650	—	—	mA
	Output ripple voltage	Vrpldd31	Iout = 0 to Iomax	—	60	—	mV
	Input stability	Vlinedd3	Vvcc1 = 2.7 V to 5.5 V	—	10	—	mV
	Load stability	Vloaddd3	Iout = -1 mA to Iomax	—	—	30	mV
	Oscillation frequency	Fdd3	PWM mode	—	1.7	—	MHz
	efficiency	η dd3	Vvcc1 = 3.3 V, Iout = -200 mA	80	90	—	%
	Rise time	Trdd3	Vvcc1 = 3.3 V, Iout = 0 mA	—	100	—	μ s
	Fall time	Tfdd3	Vvcc1 = 3.3 V, Iout = 0 mA	—	120	—	μ s

(Continued)

(Continued)

Parameter		Symbol	Condition	Value			Unit
				Min	Typ	Max	
Start/stop control block	Input voltage	Vil1	ONOFF	0.0	—	$0.3 \times V_{vcc1}$	V
		Vih1		$0.7 \times V_{vcc1}$	—	V_{vcc1}	V
		Vil2	LDOCNT1, LDOCNT2	0.0	—	$0.3 \times V_{vcc3}$	V
		Vih2		$0.7 \times V_{vcc3}$	—	V_{vcc3}	V
	Output voltage	Vol1	XRST1, XRST2, Iout = 1 mA	0.0	—	$0.15 \times V_{vcc3}$	V
		Voh1	XRST1, XRST2, Iout = -1 mA	$0.85 \times V_{vcc3}$	—	V_{vcc3}	V
	VCC1 power supply detection voltage	Vdetvon	VCC1 rise = 0.1 V/10 μ s	2.55	2.6	2.65	V
	VCC1 Voltage for power supply cut-off detection	Vdetvoff	VCC1 fall = 0.3 V/10 μ s	2.3	2.4	2.5	V
RTC block	Output voltage	Vol32k	RTC_CLK, Iout = 0.5 mA	0.0	—	$0.15 \times V_{rtc}$	V
		Voh32k	RTC_CLK, Iout = -0.5 mA	$0.85 \times V_{rtc}$	—	V_{rtc}	V
	Internal oscillation capacitance 1	Cg	OSCIN	—	10	—	pF
	Internal oscillation capacitance 2	Cd	OSCOU	—	10	—	pF
I ² C interface	Input voltage	Vil14	SCL, SDA (for input)	0.0	—	$0.3 \times V_{vcc3}$	V
		Vih14		$0.7 \times V_{vcc3}$	—	V_{vcc3}	V
	Output voltage	Vol18	SDA (for output) Iout = 3 mA	0.0	—	0.4	V
VFIL1, VFIL2	Output voltage	Vovfil1	VFIL1	1.175	1.225	1.275	V
		Vovfil2	VFIL2	0.575	0.60	0.625	V
LDO5	Output voltage	Voutld5	Iout = 0 to Iomax	2.325	2.40	2.475	V
UVLO	UVLO release voltage	Vuvlod	—	2.1	2.2	2.3	V
	UVLO detection voltage	Vuvlor	—	2.0	2.1	2.2	V
Over temperature protection (OTP)	Detection temperature	Totpd	—	+135	+150	+165	°C
	Release temperature	Totpr	—	+105	+120	+135	°C
Output short circuit protection (SCP)	Detection protection time	Tshort	Output = 0.6 V \pm 0.2 V or less	75	100	125	ms

2. AC characteristics

($T_a = -30\text{ }^\circ\text{C}$ to $+85\text{ }^\circ\text{C}$, $V_{cc1} = 2.7\text{ V}$ to 5.5 V , $V_{cc3} = 3.2\text{ V}$ to 5.5 V ,
 $V_{cc2} = 1.75\text{ V}$ to 1.90 V , $V_{rtc} = 2.35\text{ V}$ to 2.475 V)

Parameter		Symbol	Condition	Value			Unit
				Min	Typ	Max	
RTC block	Clock frequency	Fck	When using RTC_CLK, and FC_12M (manufactured by Epson Toyocom Corporation) for external crystal.	—	32.768	—	kHz
	Clock duty	Rck	When using RTC_CLK, and FC_12M (manufactured by Epson Toyocom Corporation) for external crystal.	25	50	75	%
	Margin for oscillation	Rfm	$R_{max} = 90\text{ k}\Omega$	$10 \times R_{max}$	—	—	$\text{k}\Omega$
I ² C interface	Clock frequency	Fscl	SCL	—	—	400	kHz
	Start condition hold time	Thold1	SCL, SDA	0.6	—	—	μs
	SCL clock L cycle	Tscll	SCL	1.3	—	—	μs
	SCL clock H cycle	Tsclh	SCL	0.6	—	—	μs
	Start condition set up time	Tsetup1	SCL, SDA	0.6	—	—	μs
	Data hold time	Thold2	SCL, SDA	0	—	0.9	μs
	Data set up time	Tsetup2	SCL, SDA	0.1	—	—	μs
	Stop condition set up time	Tsetup3	SCL, SDA	0.6	—	—	μs
	Bus open time between stop condition-start condition	Tbusopen	SDA	1.3	—	—	μs
	Rise time	TrI2C	SCL, SDA	—	—	300	ns
	Fall time	TfI2C	SCL, SDA	—	—	300	ns

• I²C interface

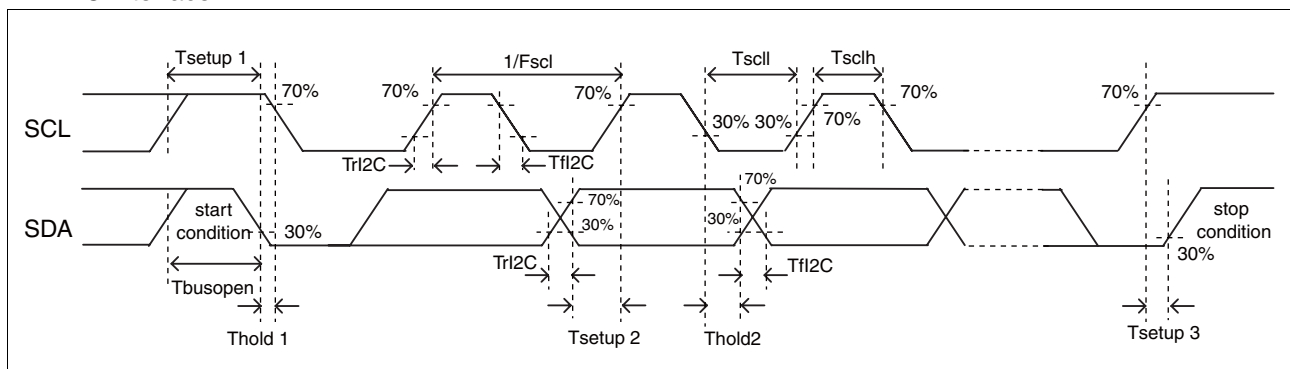

3. Current dissipation

Parameter	Condition	Value		Unit
		Typ	Max	
Standby current	ONOFF : L	150	250	μA
ON current	DC/DC1 converter, DC/DC2 converter : ON (no load) LDO1, LDO2, LDO3, LDO4 : ON (no load)	650	850	μA

■ TYPICAL CHARACTERISTICS

For the reference of design, typical characteristics are shown below.

- Characteristics of Voltage step-down DCDC (DCDC1, $V_{out} = 1.200\text{ V}$)

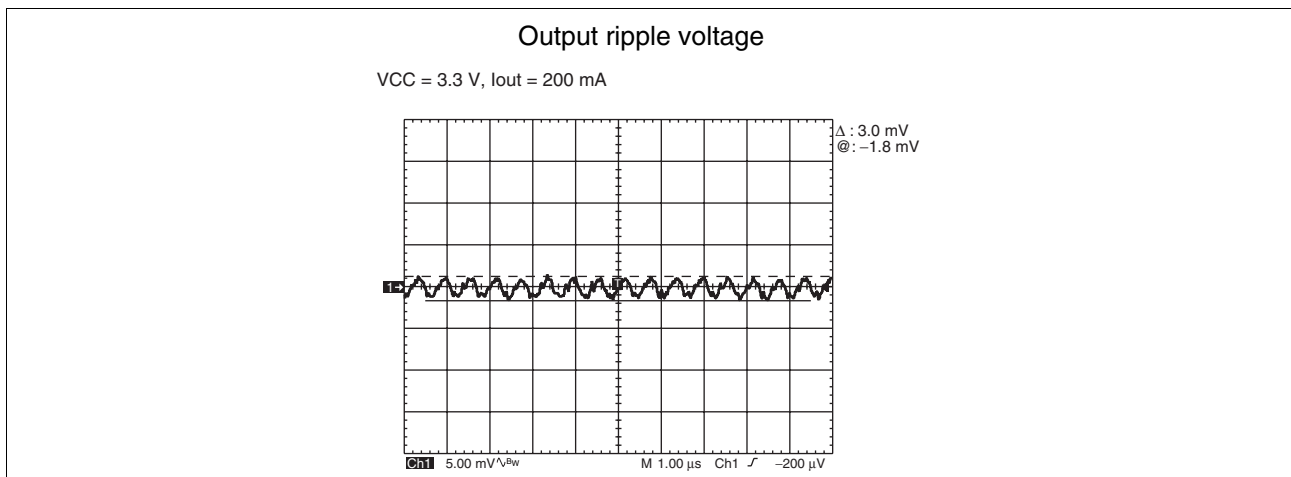
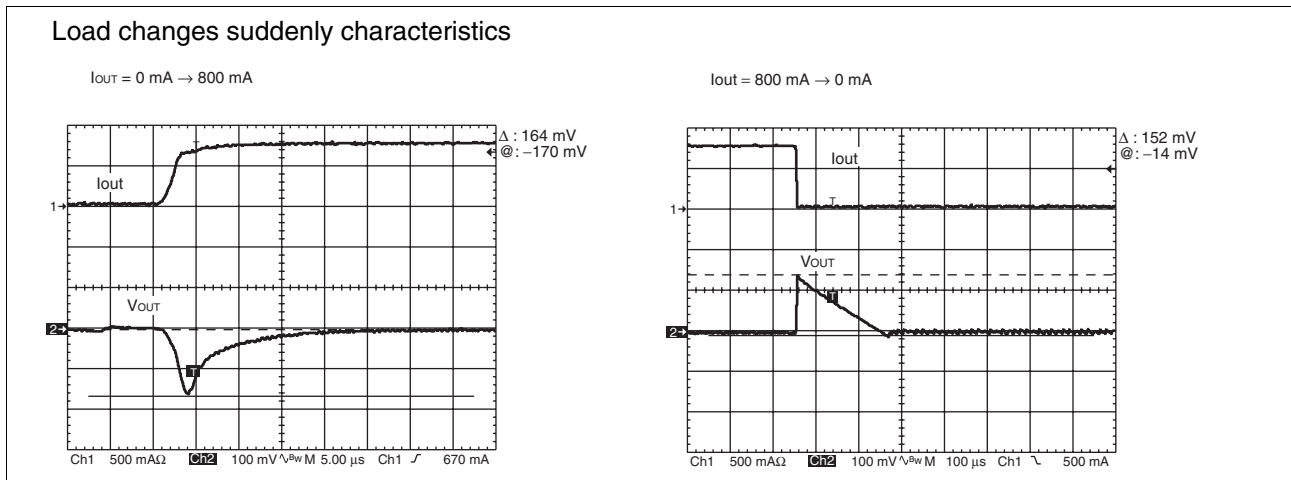
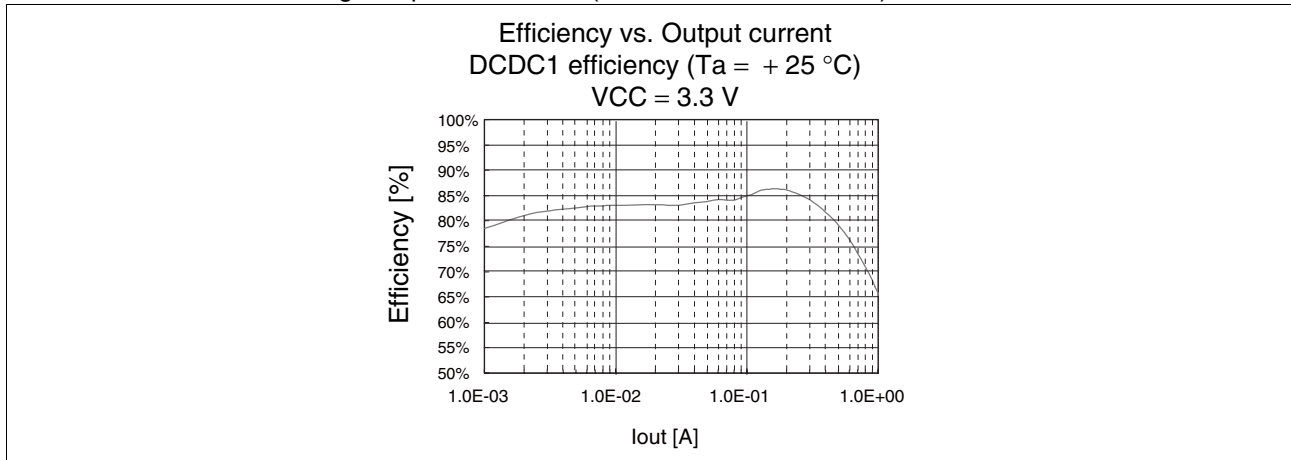

Output voltage vs. Load current characteristics
DCDC1 Output voltage vs. Load current
(Ta = + 25 °C)

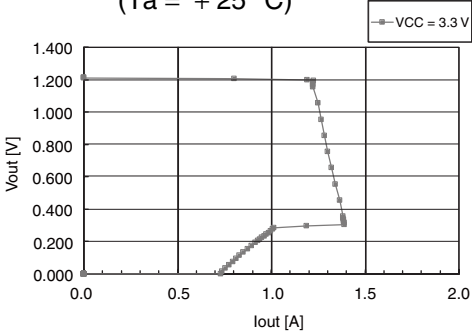

- Characteristics of Voltage step-down/up DCDC (DCDC3, $V_{out} = 3.300\text{ V}$)

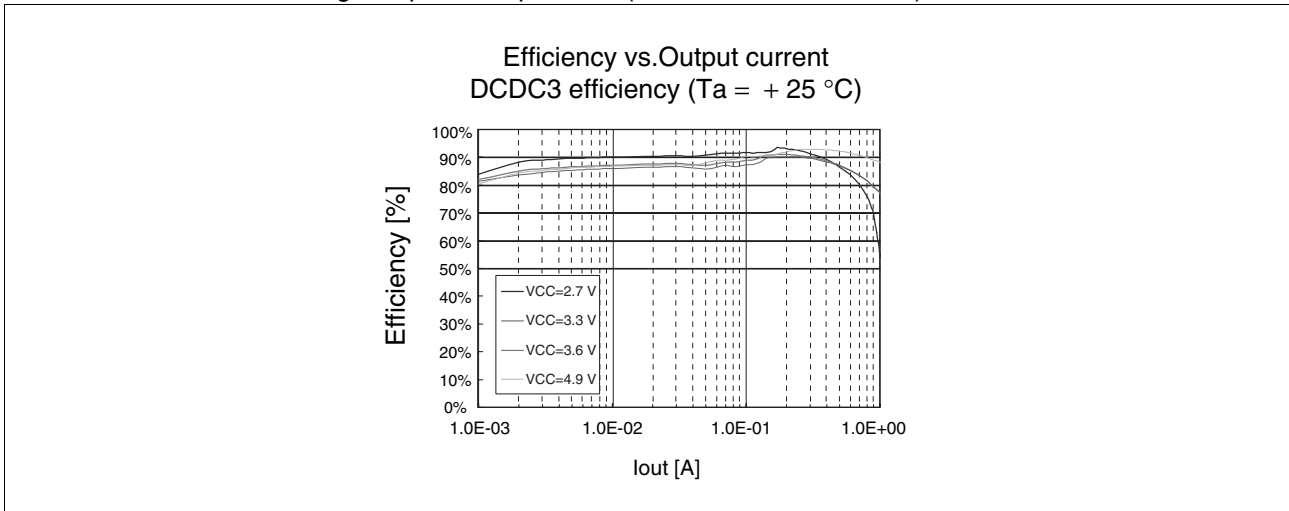

Output ripple voltage

VCC = 2.7 V, $I_{out} = 400\text{ mA}$

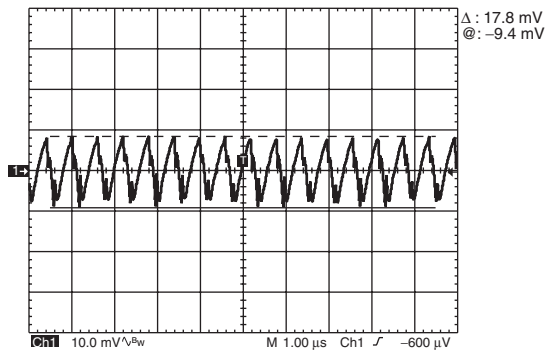

VCC = 3.3 V, $I_{out} = 400\text{ mA}$

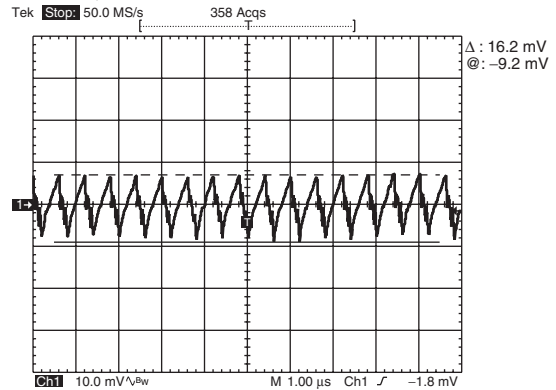

VCC = 4.9 V, $I_{out} = 400\text{ mA}$

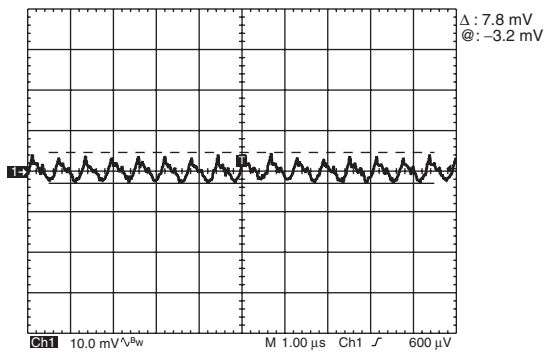

VCC = 4.9 V, $I_{out} = 0\text{ mA}$

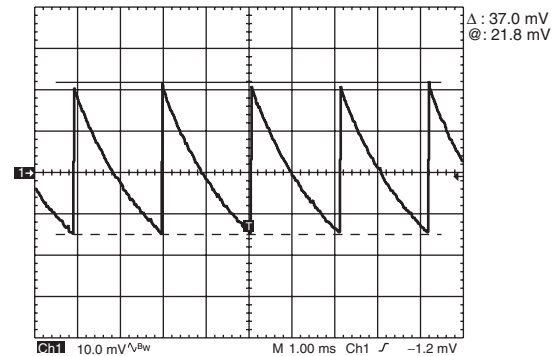

• LDO(LDO1) characteristics

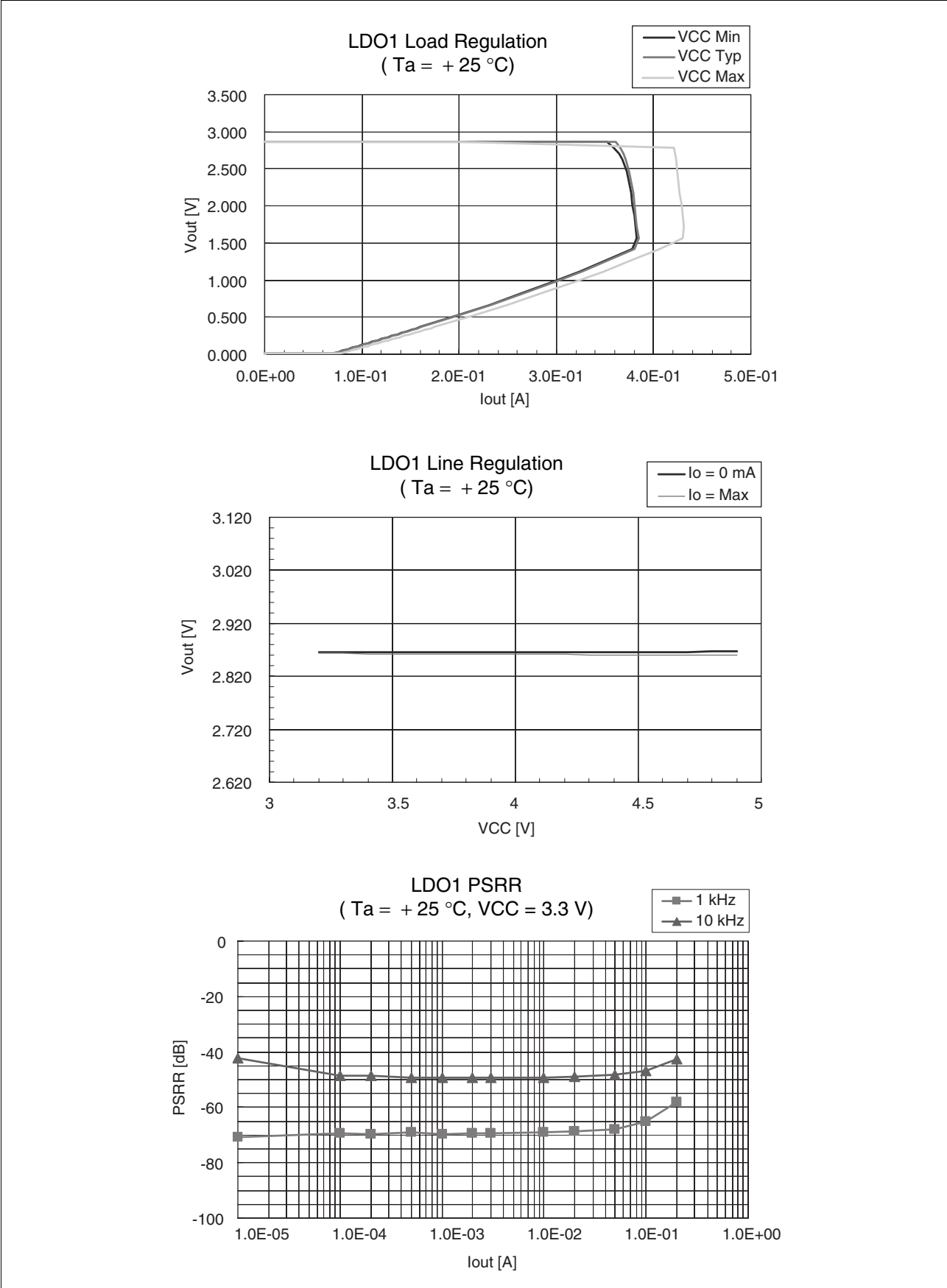

■ START/STOP CONTROL FUNCTION

Conditions of the VCC1 power supply pin and ONOFF, LDOCNT1 and LDOCNT2 pins and the setting of the REON register control the output of the LDO, the DC/DC converter and reset signals (XRST1 and XRST2). Also, the setting of the HRST register controls the output of the reset signal.

1. Conditions for start and stop

• Conditions for start

When all conditions mentioned below are completed, the LDO and the DC/DC converter will start.

- VCC1 pin input voltage 2.6 V or more
- ONOFF pin input "H"

• Conditions for stop

When one of conditions mentioned below occurs, the LDO and the DC/DC converter will stop.

- VCC1 pin input voltage 2.4 V or less
- ONOFF pin input "L"
- When the REON bit in the REON register changes "0" to "1"
- OTP (Over temperature protection) detection

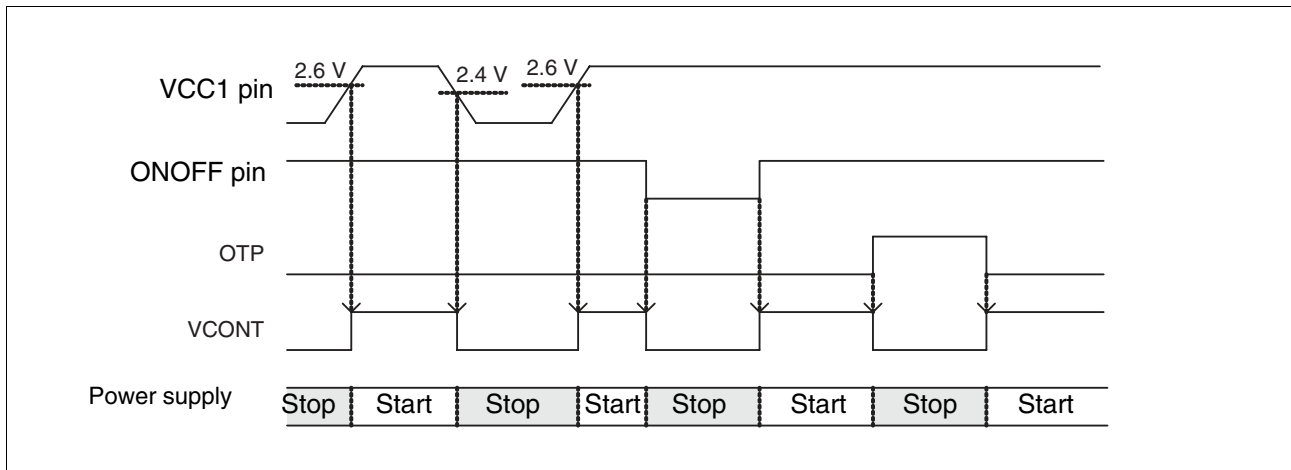

The start and stop status in the constant voltage power supply block by the VCC1 pin input voltage and the ONOFF pin input is reflected to the VCONT bit (address 05_H [0]) in the STATE register.

2. Start/stop sequence by VCC1 power supply pin and ONOFF pin

- When using VCC1 pin

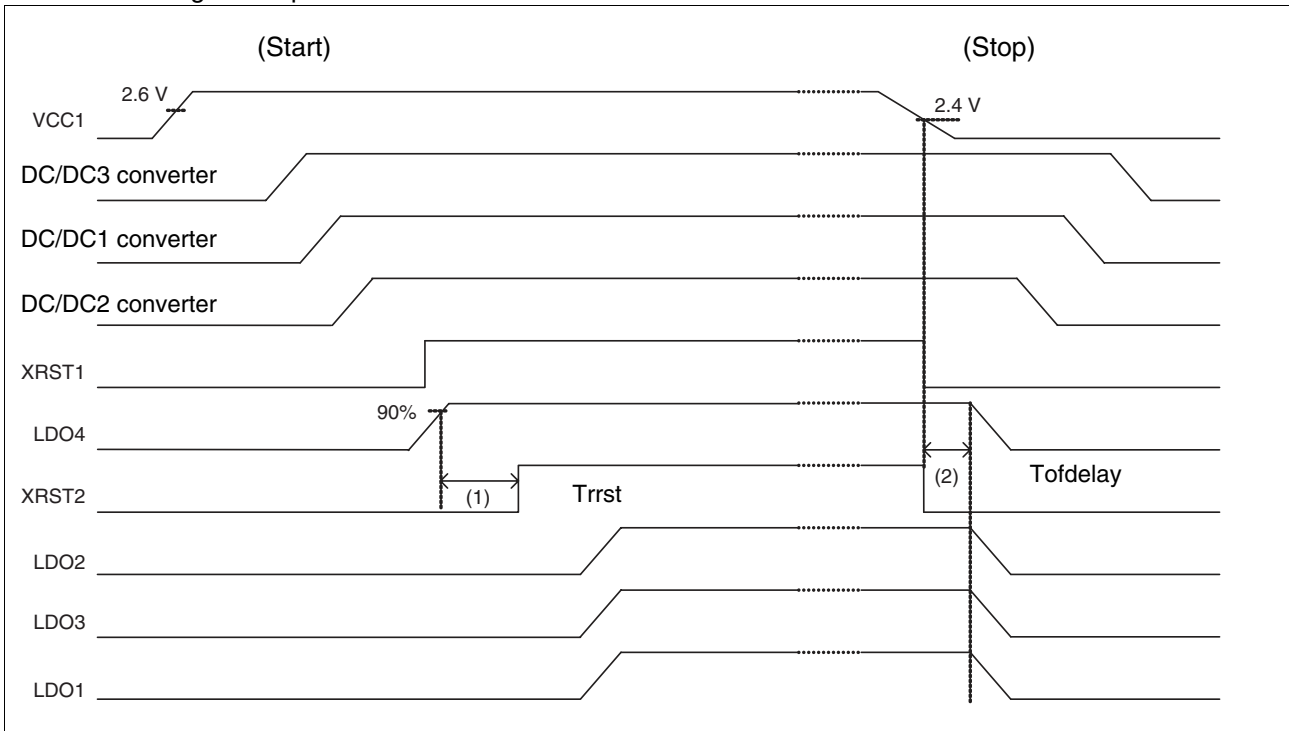

- When using ONOFF pin

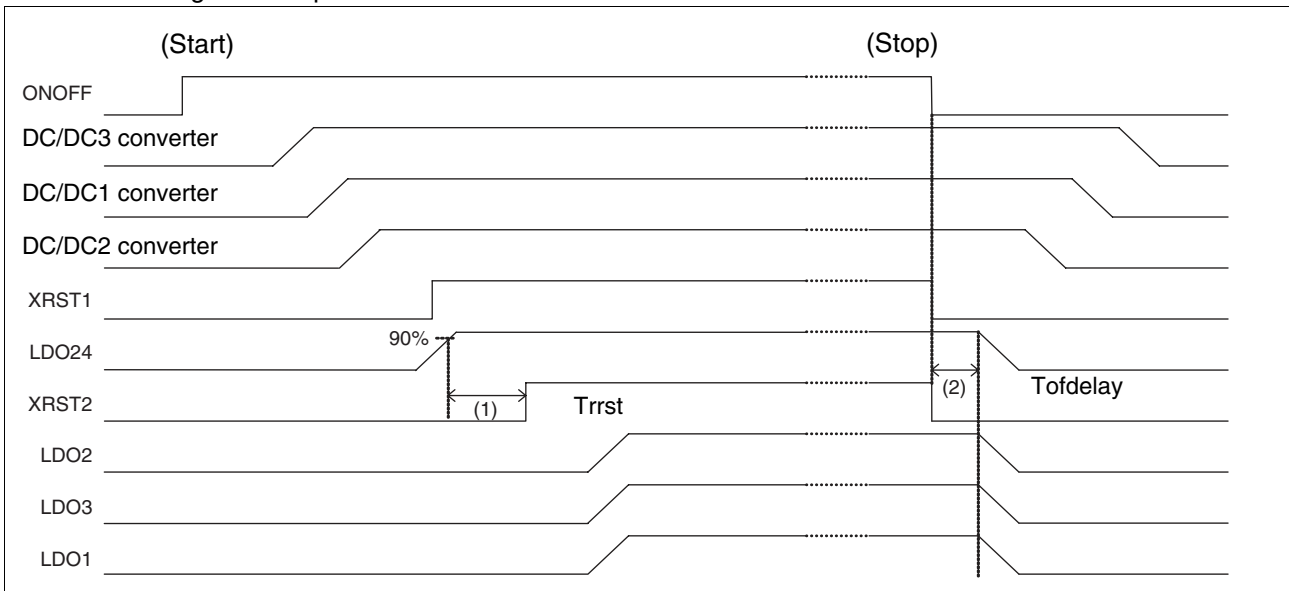

Parameter	Symbol	Value			Unit
		Min	Typ	Max	
(1)	Trrst	4	5	6	ms
(2)	Tofdelay	150	200	250	μs

3. Start/stop by LDOCNT1 and LDOCNT2 pins (intermittent control)

When the XRST1 and the XRST2 pins are in “H”, the LDO starts and stops depending on the conditions of the LDOCNT1 and the LDOCNT2 pins.

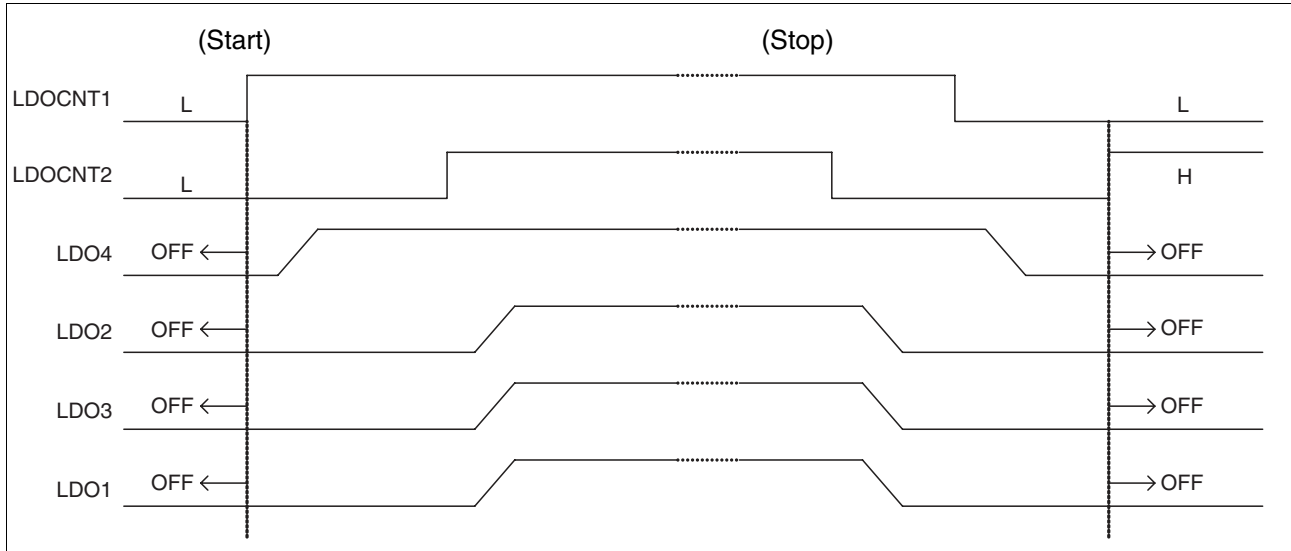

Input condition		LDO1	LDO2	LDO3	LDO4
LDOCNT1	LDOCNT2				
H	H	ON	ON	ON	ON
H	L	OFF	OFF	OFF	ON
L	L	OFF	OFF	OFF	OFF
L	H	OFF	OFF	OFF	OFF

4. Start/stop by REON register (Restart power supply)

When “1” is written to the REON bit in the REON register (address 04_H [0]), the power supply stops following the sequence and starts again after a fixed period has passed.

The STOPTIMEB bit (address 04_H [5:4]) can set the time between the stop of the power supply and the restart of the power supply (calculated by the 140 kHz internal clock). The REON bit is automatically cleared after the time set by the STOPTIMEB bit has passed.

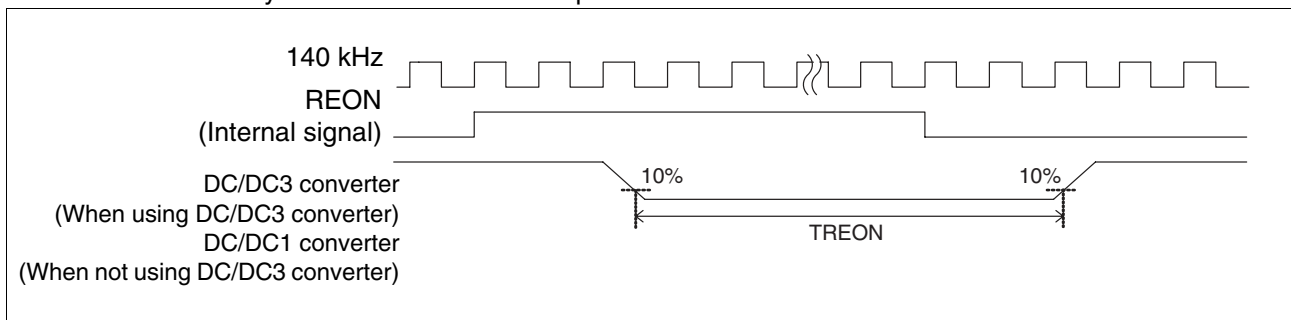

Parameter	STOPTIMEB bit [1:0]	Value			Unit
		Min	Typ	Max	
TREON	00 _B	0.8	1.0	1.2	ms
	01 _B	3.4	4.0	5.2	ms
	10 _B	6.8	8.0	9.8	ms
	11 _B	13.6	16.0	19.0	ms

5. Reset control by HRST register

When “1” is written to the HRST bit in the HRST register (address 03_H [0]), the output of XRST2 remains at “L” level for a fixed period.

The STOPTIMEA bit (address 03_H [5:4]) can set the time for remaining on XRST2 = “L”. The HRST bit is automatically cleared after the time set by the STOPTIMEA bit has passed.

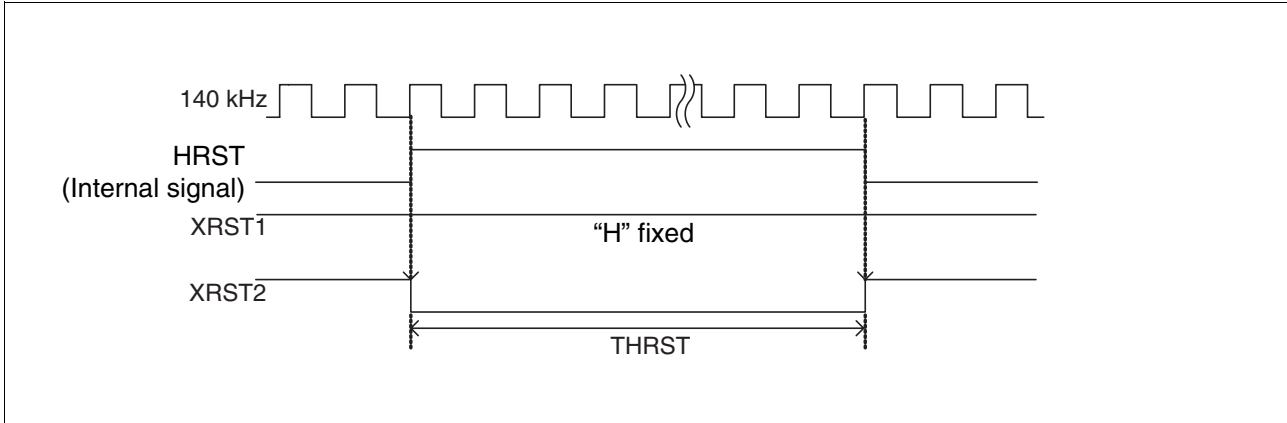

Parameter	STOPTIMEA bit [1:0]	Value			Unit
		Min	Typ	Max	
THRST	00 _B	0.8	1.0	1.2	ms
	01 _B	3.4	4.0	5.2	ms
	10 _B	6.8	8.0	9.8	ms
	11 _B	13.6	16.0	19.0	ms

■ 32.768 kHz OUTPUT (CMOS output)

If the crystal oscillator is connected to the OSCIN and the OSCOUT pins, the 32.768 kHz clock can be output from the RTC_CLK pin.

■ I²C INTERFACE

This is the interface which is compliant with the I²C bus standard. The internal register data are read and write to the internal register data via two bidirectional bus lines which are the serial data line (SDA) and the serial clock line (SCL).

The MB39C316 has the following features.

- This LSI is set as slave, so the LSI cannot be set to master.
- The slave address is “2A_H”.
- Supports high speed mode (Max 400 kbps)

1. Writing flow

- (1) Detect start condition
- (2) Receive slave address (“2A_H”) and W/R bit (“0”)
- (3) Transmit ACK
- (4) Receive register address
- (5) Transmit ACK
- (6) Receive write data
- (7) Transmit ACK
- (8) Increase the register address and then go back to (6), when a stop condition is not detected.*
- (9) Communication stops after detecting a stop condition.

* : Increment stops at address FF_H and keeps at FF_H. The flow does not go back to 00_H.

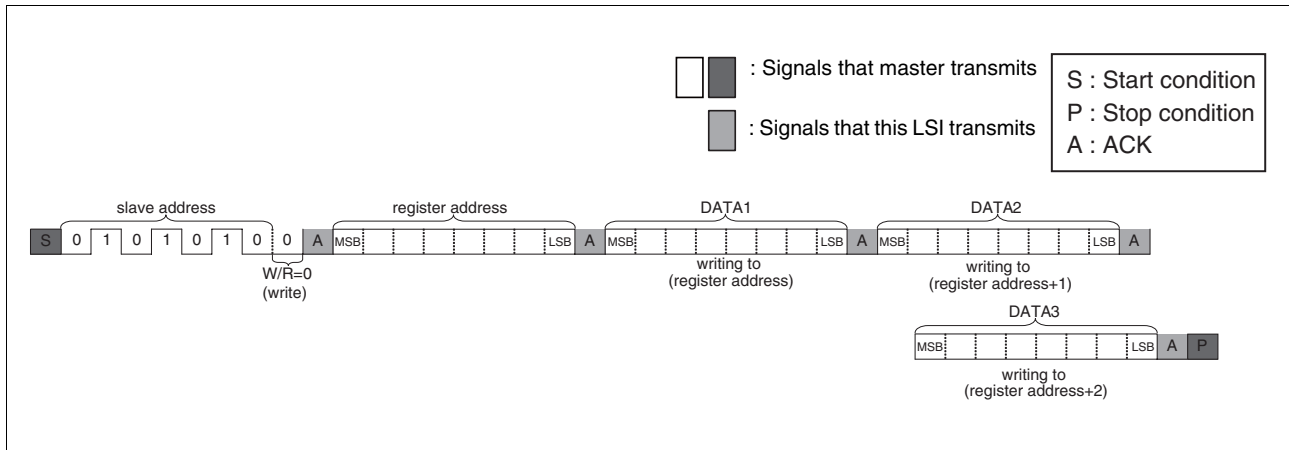

- Notes :
- If the register address which does not exist or the bit which are not assigned is specified, ACK will be returned, but data will not be written.
 - If writing is set to the Read Only address, ACK will not be returned, but data will not be written.

2. Reading flow

- (1) Detect start condition
- (2) Receive slave address ("2A_H") and W/R bit ("0")
- (3) Transmit ACK
- (4) Receive register address
- (5) Transmit ACK
- (6) Detect start condition
- (7) Receive slave address ("2A_H") and W/R bit ("1")
- (8) Transmit ACK
- (9) Transmission of read data
- (10) Increase the register address and then go back to (9).*
If [1] ACK is received. Release the bus if [2] NACK is received.
- (11) Communication stops after detecting a stop condition.

* : Increment stops at address FF_H and keeps FF_H. Increment does not go back to 00_H.

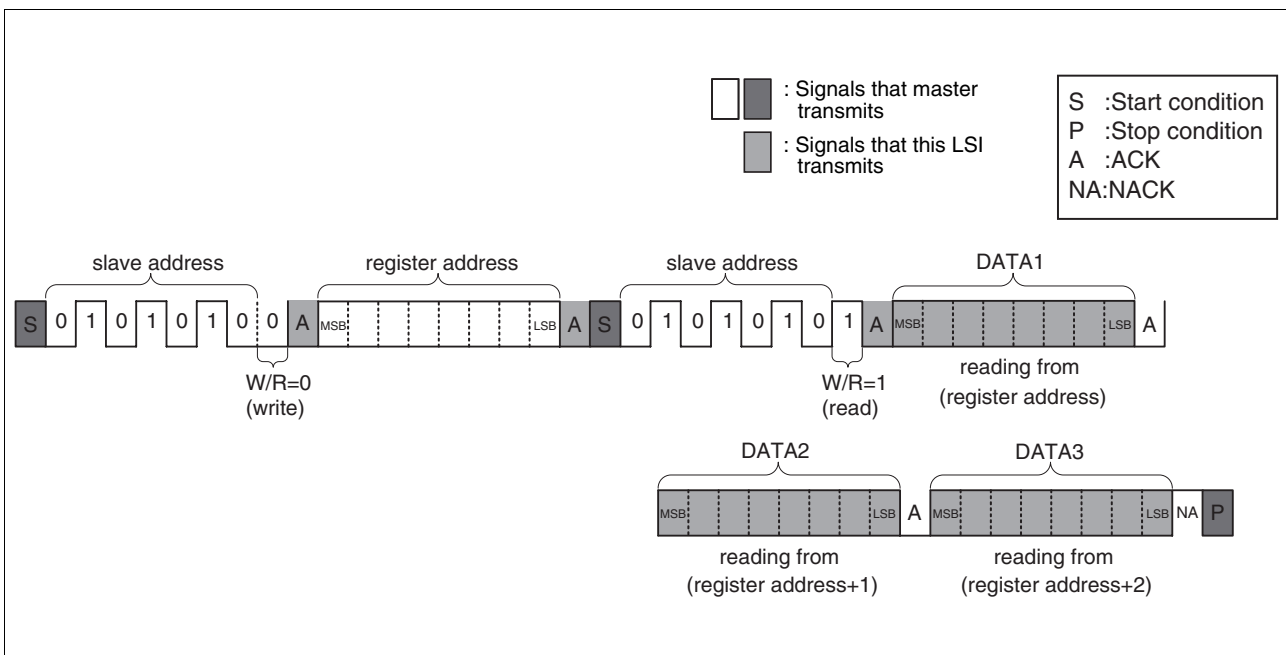

Note : If the register address which does not exist and the bit which does not execute the bit assign are specified, read data becomes "0".

■ REGISTERS

1. Address allocation

Ad- dress (hex)	Type	Register name (function)	W/R	Register Contents								Default value	
				D7	D6	D5	D4	D3	D2	D1	D0		
00	Reset	SRST (Soft reset control)	*	RSTDET	—	—	—	—	—	—	—	SRST	0000 0000
01	Version	VERSION (Information about versions)	R	—	—	—	—	VER3	VER2	VER1	VER0	0000 0011	
02	Constant voltage power supply	VSEL_SYN (LDO voltage setting)	WR	—	—	—	—	—	—	—	—	VSEL_SYN	0000 0000
03	Reset	HRST (Hard reset control)	WR	HRDET	—	STOPTI MEA1	STOPTI MEA0	—	—	—	—	HRST	0000 0000
04	Power supply control	REON (Control of re-starting power supply)	WR	REDET	—	STOPTI MEB1	STOPTI MEB0	—	—	—	—	REON	0000 0000
05	Notice of state	STATE (Notice of state)	R	—	—	—	—	CUR_lim	OTP	RTC_OSC	VCONT	0000 0000	
06	General	GP (General-purpose register)	WR	GP7	GP6	GP5	GP4	GP3	GP2	GP1	GP0	0000 0000	
07-7F	—	—	—	—	—	—	—	—	—	—	—	—	
80-8B	TEST	reserved (reserved bytes)	—	reserved	reserved	reserved	reserved	reserved	reserved	reserved	reserved	reserved	—
8C	—	—	—	—	—	—	—	—	—	—	—	—	

* : 00H [D0] is Write only, [D7] is Write/Read.

- Although data which “_” is shown is accessible to read and write, writing is invalid and reading data becomes “0”.
- All registers are initialized to the default value by power-on reset.
- Executing the soft reset control initializes all Write registers to the default value. There is a possibility that written data during execution of the soft reset control is not reflected correctly.

Note : Address 80H to 8BH is mapped on the registers for this LSI test. It is prohibited to write to 80H to 8BH when using this LSI.

2. Functional description

• Soft reset control (Address 00_H)

	D7	D6	D5	D4	D3	D2	D1	D0
At Write	RSTDET	—	—	—	—	—	—	SRST
At Read	RSTDET	0	0	0	0	0	0	0
Default	0	0	0	0	0	0	0	0

bit [7] RSTDET : Register reset history bit

RSTDET	Operation
0	No execution of soft reset control (Read)/RSTDET clear bits (Write)
1	Execution of register reset by soft reset control (Read)

This bit saves the execution history of the reset operation by the soft reset control. If the reset operation by the soft reset control is executed, this bit is set to “1”.

When clearing this bit, write “00_H” to this register.

Writing RSTDET = “1” is ignored.

bit [0] SRST : Register reset bit

SRST	Operation
0	Normal operation
1	Reset the Write register for other than address 00 _H .

If writing “1” to this bit, all Write registers are reset, and the read value for address 00_H is “80_H”.

The reset state will be remained for about 15 μs after writing SRST = “1”.

This bit is for the write only and the read value is always “0”.

- Notes :
- If RSTDET = “0” and SRST = “1” are written simultaneously, RSTDET = “0” is ignored. The reset operation by SRST = “1” is executed and the RSTDET bit is set to “1”.
 - There is a possibility that written data during the soft reset control execution is not written correctly.

• Information about versions (Address 01_H)

	D7	D6	D5	D4	D3	D2	D1	D0
At Write	—	—	—	—	—	—	—	—
At Read	0	0	0	0	VER3	VER2	VER1	VER0
Default	0	0	0	0	Fixed value for each version			

bit [3:0] VER : Version display bit

VER	Operation
0000	—
0001	1
0010	2
0011	3
:	:

This register reads information about device's versions.

• LDO voltage setting (Address 02_H)

	D7	D6	D5	D4	D3	D2	D1	D0
At Write	—	—	—	—	—	—	—	VSEL_SYN
At Read	0	0	0	0	0	0	0	VSEL_SYN
Default	0	0	0	0	0	0	0	0

bit [0] VSEL_SYN : Selection bit of LDO3 voltage

VSEL_SYN	Operation
0	1.2 V (Typ)
1	1.3 V (Typ)

This bit switches output voltage of LDO3.

• Hard reset control (Address 03_H)

	D7	D6	D5	D4	D3	D2	D1	D0
At Write	HRDET	—	STOPTIMEA1	STOPTIMEA0	—	—	—	HRST
At Read	HRDET	0	STOPTIMEA1	STOPTIMEA0	0	0	0	HRST
Default	0	0	0	0	0	0	0	0

bit [7] HRDET : HRST history bit

HRDET	Operation
0	No execution of hard reset control (Read)/HRDET clear bits (Write)
1	Execution of XRST2 reset by hard reset control (Read)

This bit saves the execution history of the reset operation by the hard reset control. The reset operation by the hard reset control sets this bit to “1” (same time as re-writing of the HRST bit). Write “00_H” to this register when clearing this bit. Writing HRDET = “1” is ignored.

bit [5:4] STOPTIMEA : XRST2 = “L” time setting bit

STOPTIMEA	Operation
00	1 ms (Typ)
01	4 ms (Typ)
10	8 ms (Typ)
11	16 ms (Typ)

This bit selects the time of XRST2 = “L” by the hard reset control.

bit [0] HRST : HRST Control bit

HRST	Operation
0	Normal operation (Read)
1	Instructions of hard reset control start (Write)

When writing “1” to this bit, the output of the XRST2 pin will remain in “L” for the time set by the STOPTIMEA bit.

This bit is automatically cleared after the time set has passed.

Note : If HRDET = “0” and HRST = “1” are written at the same time, HRDET = “0” is ignored. The reset operation is executed by HRST = “1” and the HRDET bit is set to “1”.

• Control of re-starting power supply (Address 04_H)

	D7	D6	D5	D4	D3	D2	D1	D0
At Write	REDET	—	STOPTIMEB1	STOPTIMEB0	—	—	—	REON
At Read	REDET	0	STOPTIMEB1	STOPTIMEB0	0	0	0	REON
Default	0	0	0	0	0	0	0	0

bit [7] REDET : REON history bit

REDET	Operation
0	No execution of re-starting power supply control (Read)/REDET Clear bits (Write)
1	Re-starting power supply by re-starting power supply control (Read)

This bit keeps the execution history of re-starting power supply by the re-starting power supply control. When re-starting power supply is executed by the re-starting power supply control, this bit is set to “1” (same time as re-writing of the REON bit).

Write “00_H” to this register to clear this bit.

Writing REDET = “1” is ignored.

bit [5:4] STOPTIMEB : Time setting bit to maintain power supply stop status

STOPTIMEB	Operation
00	1 ms (Typ)
01	4 ms (Typ)
10	8 ms (Typ)
11	16 ms (Typ)

This bit selects the time between completion of the stop sequence and the beginning of the re-start.

bit [0] REON : REON Control bit

REON	Operation
0	Normal operation (Read)
1	Instructions to re-start power supply (Write)

Writing “1” to this bit turns power supply on again (Stop → Start the constant voltage power supply). The power supply start sequence starts when the time set by the STOPTIMEB bit passes after the power supply stop sequence has completed.

This bit is automatically cleared after the time set has passed.

Note : If REDET = “0” and REON = “1” are written at the same time, REDET = “0” is ignored. Re-starting power supply by REON = “1” is executed, and the REDET bit is set to “1”.

- Notice of power supply state (Address 05_H)

	D7	D6	D5	D4	D3	D2	D1	D0
At Write	—	—	—	—	—	—	—	—
At Read	0	0	0	0	CUR_lim	OTP	RTC_OSC	VCONT
Default	0	0	0	0	0	0	0	0

bit [3] CUR_lim : Display bit to detect short circuit

CUR_lim	Operation
0	Detection of no short circuit
1	Detection of short circuit

This bit reads detection signals of short circuit.

bit [2] OTP : OTP status display bit

OTP	Operation
0	No problem with over temperature
1	Problem with over temperature

This bit reads the abnormal over temperature signal.

bit [1] RTC_OSC : RTC oscillation status display bit

RTC_OSC	Operation
0	Oscillation stop
1	Normal oscillation

This bit reads the oscillation status of the RTC clock.

bit [0] VCONT : VCONT Status display bit

VCONT	Operation
0	VCONT = L (power supply stops)
1	VCONT = H (power supply starts)

This bit reads the VCONT status.

- General-purpose register (Address 06_H)

	D7	D6	D5	D4	D3	D2	D1	D0
At Write	GP7	GP6	GP5	GP4	GP3	GP2	GP1	GP0
At Read	GP7	GP6	GP5	GP4	GP3	GP2	GP1	GP0
Default	0	0	0	0	0	0	0	0

bit [7:0] GP : general-purpose register

This register is the general-purpose register which can be used by users freely. It is possible to read and write to "0/1".

This register is reset to the default value by the soft reset control and power-on reset.

■ PROTECTION FUNCTIONS

1. Over current protection (OCP)

This function controls the current value of the LDO and the DC/DC converter in the over load condition. When the output current excessively increases, the output voltage drops dramatically so as not to exceed the current of the over current protection operation. The output of the LDO and the DC/DC converter stops when the output voltage drops dramatically below the short circuit protection detection voltage.

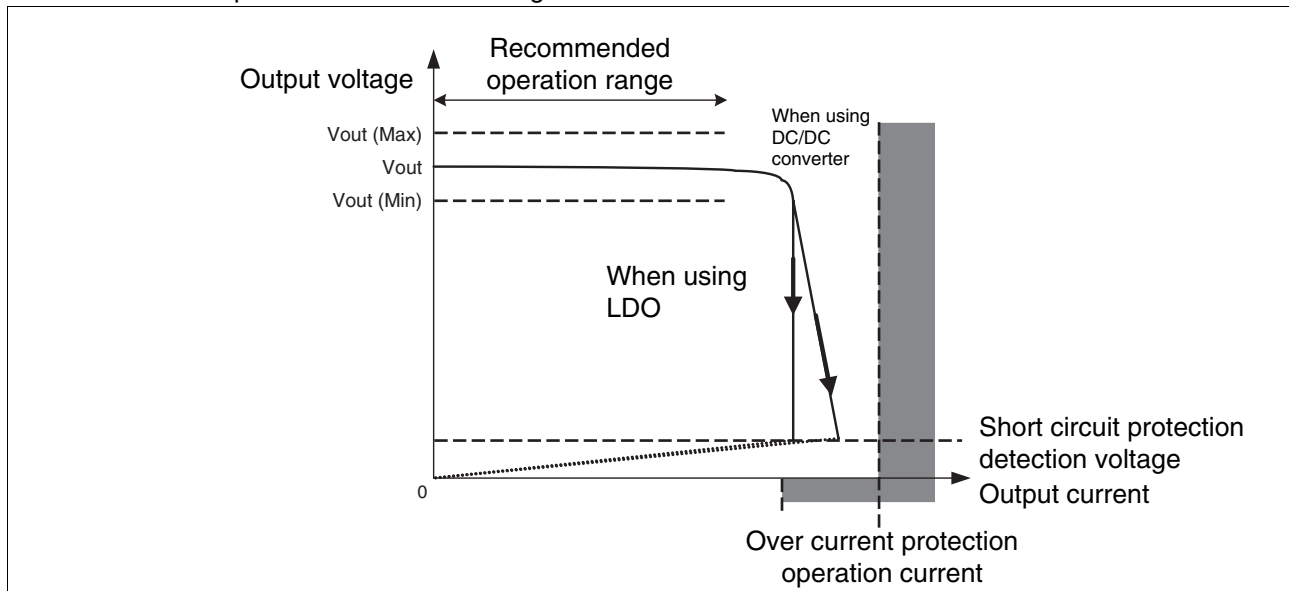

2. Output Short Circuit Protection (SCP)

If either of the LDO and the DC/DC converter output short circuit (GND short circuit) continues for 100 ms (Typ), all output of the LDO and the DC/DC converter except LDO5 stop. The output short circuit protection is released by power-on reset, and each output of the LDO and the DC/DC converter is restarted following the start sequence when the VCC1 pin exceeds 2.6 V (Typ).

3. Under Voltage Lock Out (UVLO)

When the VCC1 pin becomes less than 2.1 V (Typ), the inside of LSI is reset by the UVLO protection (power-on reset). The UVLO is released when the VCC1 pin becomes more than 2.2 V (Typ).

4. Over temperature protection (OTP)

If the chip temperature exceeds +150 °C (Typ), all output of the LDO and the DC/DC converter except for the LDO5 stop. If the chip temperature drops below +120 °C (Typ), OTP is released and each output of the LDO and the DC/DC converter is automatically restarted.

MB39C316

■ TYPICAL APPLICATION CIRCUIT

1. When using DC/DC3 converter

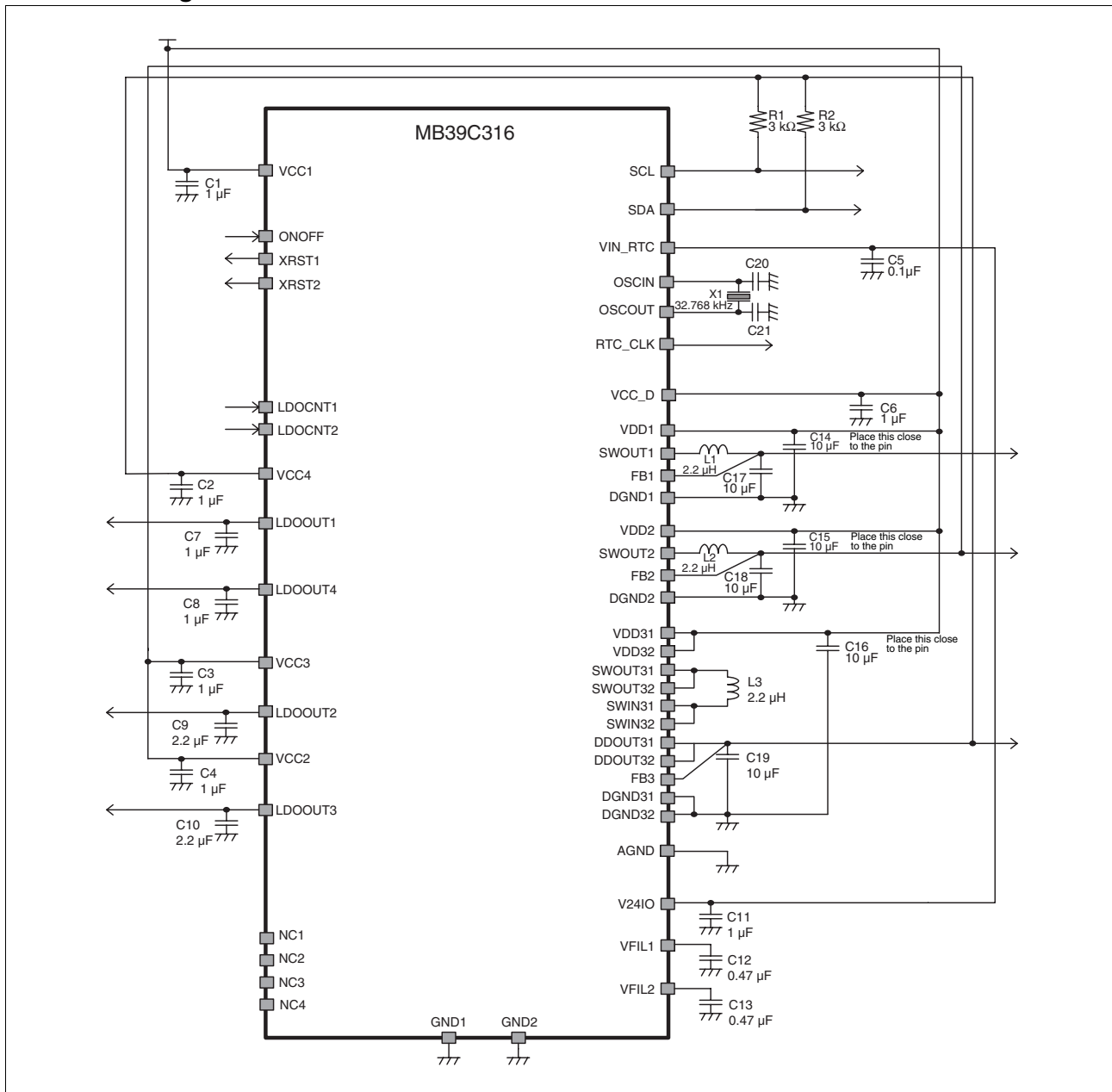

2. When not using DC/DC3 converter

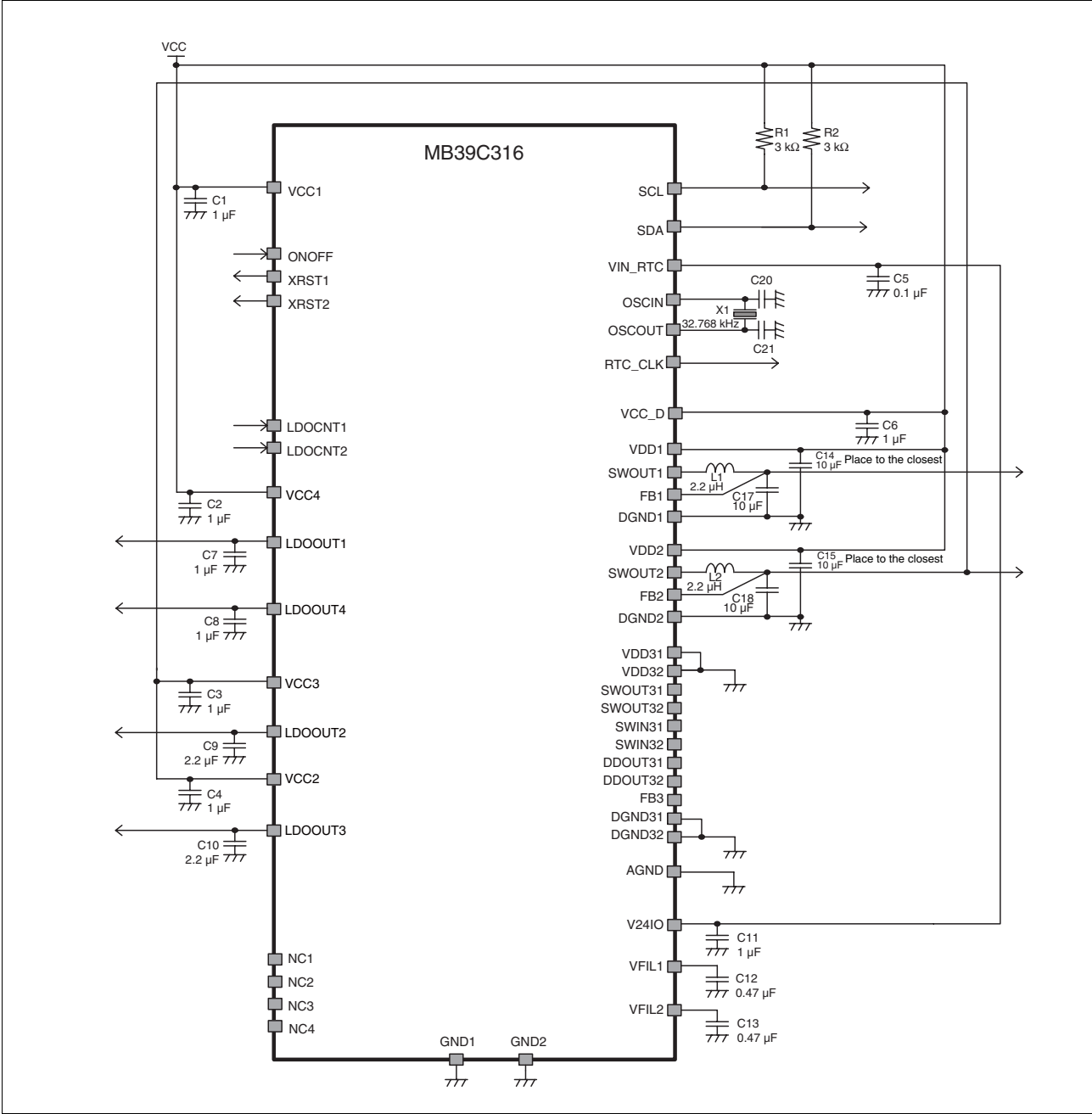

■ PART LIST

Circuit symbol	Part characteristic	Package	Application	Recommended part
C1	1 μ F	Ceramic	Power supply input	—
C2	1 μ F	Ceramic	Power supply input	—
C3	1 μ F	Ceramic	Power supply input	—
C4	1 μ F	Ceramic	Power supply input	—
C5	0.1 μ F	Ceramic	Power supply input	—
C6	1 μ F	Ceramic	Power supply input	—
C7	1.0 μ F (6.3 V, \pm 10%)	Ceramic	LDO1 output capacitor	GRM155B30J105K(murata)
C8	1.0 μ F (6.3 V, \pm 10%)	Ceramic	LDO4 output capacitor	GRM155B30J105K(murata)
C9	2.2 μ F (4.0 V, \pm 20%)	Ceramic	LDO2 output capacitor	GRM155B30G225M(murata)
C10	2.2 μ F (4.0 V, \pm 20%)	Ceramic	LDO3 output capacitor	GRM155B30G225M(murata)
C11	1.0 μ F (6.3 V, \pm 10%)	Ceramic	LDO5 output capacitor	GRM155B30J105K(murata)
C12	0.47 μ F (6.3 V, \pm 10%)	Ceramic	VFIL1 output capacitor	GRM155B30J474K(murata)
C13	0.47 μ F (6.3 V, \pm 10%)	Ceramic	VFIL2 output capacitor	GRM155B30J474K(murata)
C14	10 μ F (6.3 V, \pm 20%)	Ceramic	DC/DC1 converter input capacitor	GRM188B30J106M(murata)
C15	10 μ F (6.3 V, \pm 20%)	Ceramic	DC/DC2 converter input capacitor	GRM188B30J106M(murata)
C16	10 μ F (6.3 V, \pm 20%)	Ceramic	DC/DC3 converter input capacitor	GRM188B30J106M(murata)
C17	10 μ F (6.3 V, \pm 20%)	Ceramic	DC/DC1 converter output capacitor	GRM188B30J106M(murata)
C18	10 μ F (6.3 V, \pm 20%)	Ceramic	DC/DC2 converter output capacitor	GRM188B30J106M(murata)
C19	10 μ F (6.3 V, \pm 20%)	Ceramic	DC/DC3 converter output capacitor	GRM188B30J106M(murata)
C20	—	—	RTC block frequency adjustment	—
C21	—	—	RTC block frequency adjustment	—
L1	2.2 μ H	Multi layered	DC/DC1 converter Coil	MIPSTZ2012D2R2(FDK)
L2	2.2 μ H	Multi layered	DC/DC2 converter Coil	MIPSTZ2012D2R2(FDK)
L3	2.2 μ H	Multi layered	DC/DC3 converter Coil	MIPSAZ3225D2R2(FDK)
R1	3 k Ω	—	SCL pull-up resistor	—
R2	3 k Ω	—	SDA pull-up resistor	—
X1	32.768 kHz	—	—	FC-12M(Epson Toyocom)

FDK : FDK Corporation
 Epson Toyocom : Epson Toyocom Corporation
 murata : Murata Manufacturing Co., Ltd.

1. External parts for DC/DC converter

1. A capacitor (10 μ F) between the DC/DC converter power supply and GND pins needs to be connected at the closest place to both pins.
2. A coil needs to be selected with consideration for the frequency characteristics of inductance and DC bias characteristics.

1. External parts for DC/DC converter

1. A capacitor (10 μ F) between the DC/DC converter power supply and GND pins needs to be connected at the closest place to both pins.
2. A coil needs to be selected with consideration for the frequency characteristics of inductance and DC bias characteristics.
3. A capacitor needs to be selected with consideration for the DC bias characteristic of its capacitance.

2. External parts for LDO

1. A capacitor between the LOD output and GND pins needs to be connected at the closest place to both pins.
2. A capacitor needs to be selected with consideration for the DC bias and AC characteristics of its capacitance.

■ USAGE PRECAUTION

1. Do not configure the IC over the maximum ratings.

If the IC is used over the maximum ratings, the LSI may be permanently damaged.

It is preferable for the device to normally operate within the recommended usage conditions. Usage outside of these conditions can have an adverse effect on the reliability of the LSI.

2. Use the device within the recommended operating conditions.

The recommended values guarantee the normal LSI operation under the recommended operating conditions. The electrical ratings are guaranteed when the device is used within the recommended operating conditions and under the conditions stated for each item.

3. Printed circuit board ground lines should be set up with consideration for common impedance.

4. Take appropriate measures against static electricity.

- Containers for semiconductor materials should have anti-static protection or be made of conductive material.
- After mounting, printed circuit boards should be stored and shipped in conductive bags or containers.
- Work platforms, tools, and instruments should be properly grounded.
- Working personnel should be grounded with resistance of 250 kΩ to 1 MΩ in serial body and ground.

5. Do not apply negative voltages.

The use of negative voltages below -0.3 V may make the parasitic transistor activated to the LSI, and can cause malfunctions.

■ ORDERING INFORMATION

Part number	Package	Remarks
MB39C316PW-G-ERE1	WL-CSP pin (WLP-49P-M01)	Lead free version

■ EV BOARD ORDERING INFORMATION

EV board number	EV board version No.	Remarks
MB39C316EVB	1.0	



■ RoHS COMPLIANCE INFORMATION OF LEAD (Pb) FREE VERSION

The LSI products of Fujitsu Microelectronics with "E1" are compliant with RoHS Directive, and has observed the standard of lead, cadmium, mercury, Hexavalent chromium, polybrominated biphenyls (PBB), and polybrominated diphenyl ethers (PBDE). A product whose part number has trailing characters "E1" is RoHS compliant.

■ LABELING SAMPLE (Lead-free version)

Lead-free mark

JEITA logo JEDEC logo

MB123456P - 789 - GE1
(3N) 1MB123456P-789-GE1 1000

(3N)2 1561190005 107210

1,000 PCS
MB123456P - 789 - GE1

2006/03/01 ASSEMBLED IN JAPAN

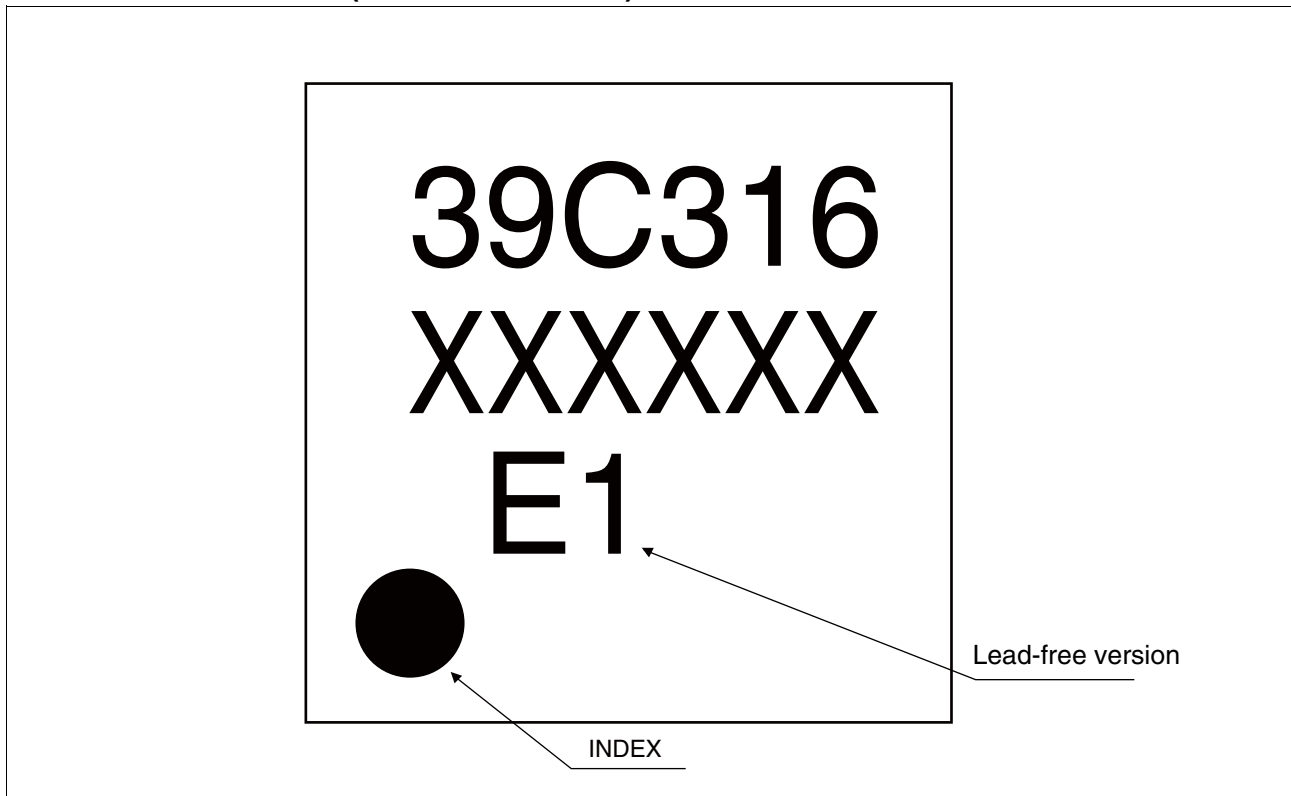
MB123456P - 789 - GE1

1561190005 1/1 0605 - Z01A 1000

The part number of a lead-free product has the trailing characters "E1".

■ MARKING FORMAT (Lead-free version)

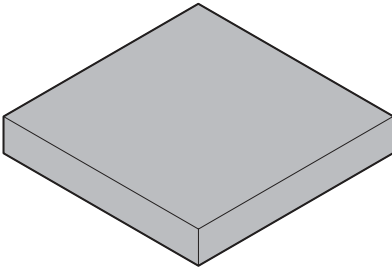

■ PACKAGE DIMENSIONS

<p>49-pin plastic WLP</p>  <p>(WLP-49P-M01)</p>	Lead pitch	0.40 mm
	Package width × package length	3.14 mm × 3.11 mm
	Lead shape	Soldering ball
	Sealing method	Print
	Mounting height	0.80 mm MAX
	Weight	0.0145 g

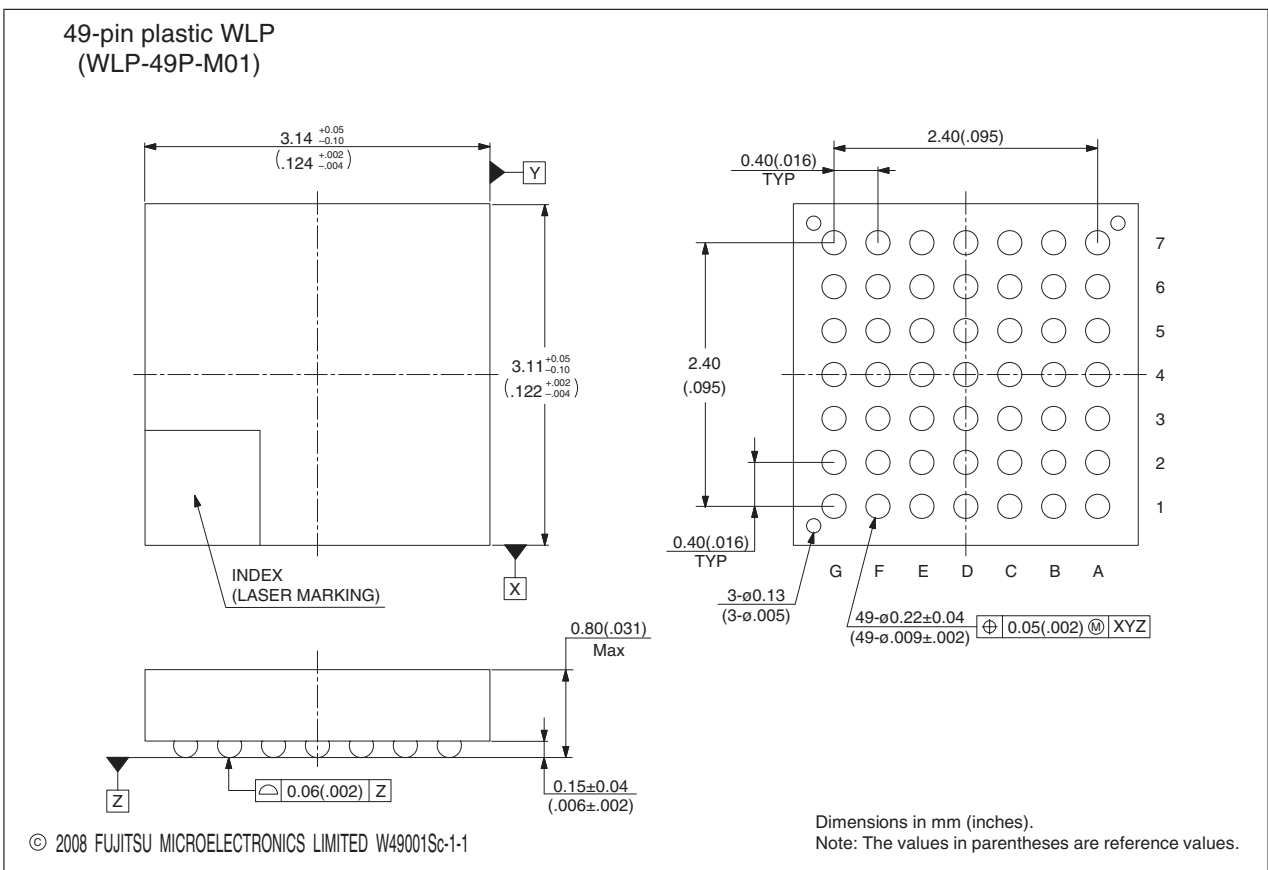

Please confirm the latest Package dimension by following URL.
<http://edevic.fujitsu.com/package/en-search/>

■ CONTENTS

	page
- DESCRIPTION	1
- FEATURES	1
- APPLICATIONS	1
- PIN ASSIGNMENT	2
- PIN DISCRPTIONS	3
- BLOCK DIAGRAM	5
- ABSOLUTE MAXIMUM RATINGS	6
- RECOMMENDED OPERATION CONDITIONS	6
- ELECTRICAL CHARACTERISTICS	7
- TYPICAL CHARACTERISTICS	12
- START/STOP CONTROL FUNCTION	16
- 32.768 kHz OUTPUT (CMOS output)	19
- I2C INTERFACE	20
- REGISTERS	22
- PROTECTION FUNCTIONS	27
- TYPICAL APPLICATION CIRCUIT	28
- PART LIST	30
- USAGE PRECAUTION	32
- ORDERING INFORMATION	32
- EV BOARD ORDERING INFORMATION	32
- RoHS COMPLIANCE INFORMATION OF LEAD (Pb) FREE VERSION	32
- LABELING SAMPLE (Lead-free version)	33
- MARKING FORMAT (Lead-free version)	34
- PACKAGE DIMENSIONS	35

MEMO

MEMO

MEMO

FUJITSU MICROELECTRONICS LIMITED

Shinjuku Dai-Ichi Seimei Bldg., 7-1, Nishishinjuku 2-chome,
Shinjuku-ku, Tokyo 163-0722, Japan
Tel: +81-3-5322-3347 Fax: +81-3-5322-3387
<http://jp.fujitsu.com/fml/en/>

For further information please contact:

North and South America

FUJITSU MICROELECTRONICS AMERICA, INC.
1250 E. Arques Avenue, M/S 333
Sunnyvale, CA 94085-5401, U.S.A.
Tel: +1-408-737-5600 Fax: +1-408-737-5999
<http://www.fma.fujitsu.com/>

Asia Pacific

FUJITSU MICROELECTRONICS ASIA PTE. LTD.
151 Lorong Chuan,
#05-08 New Tech Park 556741 Singapore
Tel : +65-6281-0770 Fax : +65-6281-0220
<http://www.fmal.fujitsu.com/>

Europe

FUJITSU MICROELECTRONICS EUROPE GmbH
Pittlerstrasse 47, 63225 Langen, Germany
Tel: +49-6103-690-0 Fax: +49-6103-690-122
<http://emea.fujitsu.com/microelectronics/>

FUJITSU MICROELECTRONICS SHANGHAI CO., LTD.

Rm. 3102, Bund Center, No.222 Yan An Road (E),
Shanghai 200002, China
Tel : +86-21-6146-3688 Fax : +86-21-6335-1605
<http://cn.fujitsu.com/fmc/>

Korea

FUJITSU MICROELECTRONICS KOREA LTD.
206 Kosmo Tower Building, 1002 Daechi-Dong,
Gangnam-Gu, Seoul 135-280, Republic of Korea
Tel: +82-2-3484-7100 Fax: +82-2-3484-7111
<http://kr.fujitsu.com/fmk/>

FUJITSU MICROELECTRONICS PACIFIC ASIA LTD.

10/F., World Commerce Centre, 11 Canton Road,
Tsimshatsui, Kowloon, Hong Kong
Tel : +852-2377-0226 Fax : +852-2376-3269
<http://cn.fujitsu.com/fmc/en/>

Specifications are subject to change without notice. For further information please contact each office.

All Rights Reserved.

The contents of this document are subject to change without notice.

Customers are advised to consult with sales representatives before ordering.

The information, such as descriptions of function and application circuit examples, in this document are presented solely for the purpose of reference to show examples of operations and uses of FUJITSU MICROELECTRONICS device; FUJITSU MICROELECTRONICS does not warrant proper operation of the device with respect to use based on such information. When you develop equipment incorporating the device based on such information, you must assume any responsibility arising out of such use of the information.

FUJITSU MICROELECTRONICS assumes no liability for any damages whatsoever arising out of the use of the information.

Any information in this document, including descriptions of function and schematic diagrams, shall not be construed as license of the use or exercise of any intellectual property right, such as patent right or copyright, or any other right of FUJITSU MICROELECTRONICS or any third party or does FUJITSU MICROELECTRONICS warrant non-infringement of any third-party's intellectual property right or other right by using such information. FUJITSU MICROELECTRONICS assumes no liability for any infringement of the intellectual property rights or other rights of third parties which would result from the use of information contained herein.

The products described in this document are designed, developed and manufactured as contemplated for general use, including without limitation, ordinary industrial use, general office use, personal use, and household use, but are not designed, developed and manufactured as contemplated (1) for use accompanying fatal risks or dangers that, unless extremely high safety is secured, could have a serious effect to the public, and could lead directly to death, personal injury, severe physical damage or other loss (i.e., nuclear reaction control in nuclear facility, aircraft flight control, air traffic control, mass transport control, medical life support system, missile launch control in weapon system), or (2) for use requiring extremely high reliability (i.e., submersible repeater and artificial satellite).

Please note that FUJITSU MICROELECTRONICS will not be liable against you and/or any third party for any claims or damages arising in connection with above-mentioned uses of the products.

Any semiconductor devices have an inherent chance of failure. You must protect against injury, damage or loss from such failures by incorporating safety design measures into your facility and equipment such as redundancy, fire protection, and prevention of over-current levels and other abnormal operating conditions.

Exportation/release of any products described in this document may require necessary procedures in accordance with the regulations of the Foreign Exchange and Foreign Trade Control Law of Japan and/or US export control laws.

The company names and brand names herein are the trademarks or registered trademarks of their respective owners.

Edited: Sales Promotion Department