

GateMate™ FPGA Datasheet

CCGM1A1

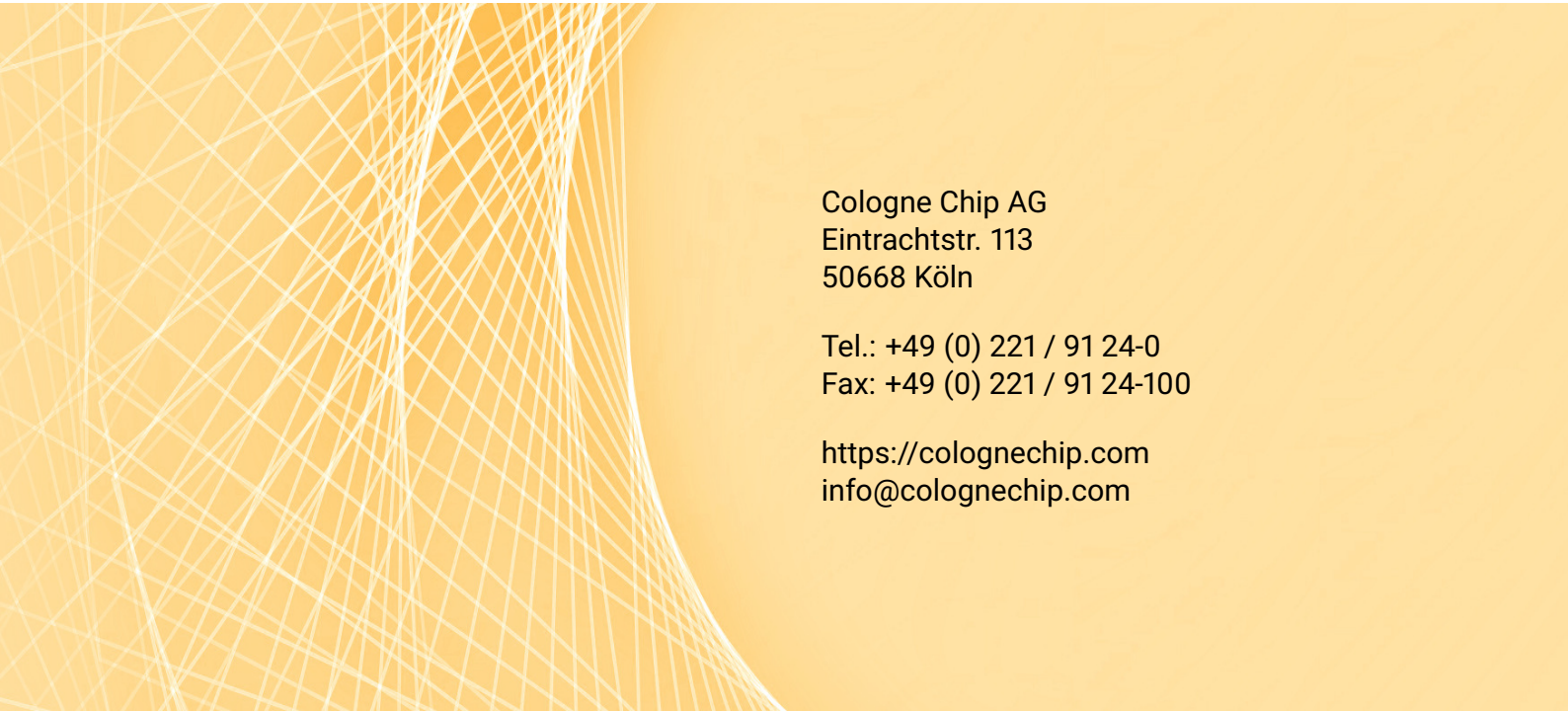



Cologne Chip AG
Eintrachtstr. 113
50668 Köln

Tel.: +49 (0) 221 / 91 24-0
Fax: +49 (0) 221 / 91 24-100

<https://colognechip.com>
info@colognechip.com

Copyright 2019 - 2023 Cologne Chip AG

All Rights Reserved

The information presented can not be considered as assured characteristics. Data can change without notice. Parts of the information presented may be protected by patent or other rights. Cologne Chip products are not designed, intended, or authorized for use in any application intended to support or sustain life, or for any other application in which the failure of the Cologne Chip product could create a situation where personal injury or death may occur.

Contents

About this Document	13
1 Introduction	17
1.1 Introduction	17
1.2 Features	18
2 Architecture	21
2.1 GateMate (TM) FPGA Overview	21
2.2 Cologne Programmable Element (CPE)	22
2.3 General purpose input / output (GPIO)	24
2.4 Embedded Block RAM	27
2.4.1 Block RAM Overview	27
2.4.2 Block RAM Architecture	28
2.4.3 TDP Mode	30
2.4.4 SDP Mode	31
2.4.5 Expanding Data Widths and Cascade Mode	33
2.4.6 Memory Mapping and Content Initialization	33
2.4.7 ECC Encoding / Decoding	34
2.4.8 RAM Access Modes and Enable	36
2.4.9 FIFO Application	37
2.5 Clock Generators (PLL)	45

2.6	Global Mesh Architecture	46
2.6.1	Overview of the Global Mesh Signal Injection	46
2.6.2	Clock Input Multiplexers CLKIN	46
2.6.3	PLL Wrapper	46
2.6.4	GLBOUT Multiplexers	49
2.6.5	Use of the CC_BUFPG Elements in HDL Design Sources	51
2.7	Clocking Schemes	52
2.7.1	The Methods of Clock Distribution	52
2.7.2	Clock Distribution via the Routing Structure	56
2.7.3	Clock Distribution via the Global Mesh	56
2.7.4	Clock Distribution via CPLs	56
2.7.4.1	Intake CPE with chained CPE row	58
2.7.4.2	Intake BES with chained BES row	59
2.7.4.3	Unchained BES row with Global Mesh pick-up	60
2.7.4.4	Intake LES with chained CPE row	61
2.8	Routing Structure	62
2.9	Power Supply	64
3	Workflow and Hardware Setup	65
3.1	FPGA Workflow	65
3.1.1	Overview	65
3.1.2	Synthesis	67
3.1.3	Implementation	68
3.1.4	Configuration	71
3.2	Hardware Setup	74
3.2.1	Power-on Reset	74
3.2.2	FPGA reset using the POR module	75
3.2.3	FPGA reset without POR module	76
3.3	Configuration Procedure	78
3.3.1	Configuration Modes	78
3.3.2	Configuration Signals	79
3.3.3	SPI Configuration	80
3.4	JTAG Interface	83
3.4.1	JTAG overview	83

3.4.2	JTAG Usage	84
3.4.3	Common JTAG Instructions	84
3.4.4	JTAG Configuration	85
3.4.5	Access to SPI Bus	86
3.4.6	Access to SPI data flash	88
3.4.7	Boundary-Scan Test	90
4	Electrical Characteristics	93
5	Pinout	97
5.1	CCGM1A1 324-Ball FBGA Pinout	97
5.2	CCGM1A1 Pinout Description	99
6	Mechanical Dimensions	111
7	Soldering Guidelines	113
	Acronyms	115

List of Figures

2.1	Simplified architecture overview	21
2.2	Cologne Programmable Element (CPE)	22
2.3	GPIO cell in single-ended mode	24
2.4	GPIO cell in LVDS mode	25
2.5	GPIO bank	26
2.6	Block RAM arrangement	27
2.7	High level block diagram of a block RAM cell	29
2.8	Internal data flow of DPSRAM in TDP 20K mode	31
2.9	Internal data flow of DPSRAM in TDP 40K mode	31
2.10	Internal data flow of DPSRAM in SDP 20K mode	32
2.11	Internal data flow of DPSRAM in SDP 40K mode	32
2.12	Structure of two adjacent DPSRAMs forming one 64K × 1 bit memory via cascade feature	34
2.13	Logical data mapping of memory at physical address 0	35
2.14	Timing diagram of a single read access	37
2.15	Timing diagram of a NO CHANGE access	37
2.16	Timing diagram of a WRITE THROUGH access	38
2.17	Internal data flow of DPSRAM in FIFO mode	38
2.18	Writing to an empty synchronous FIFO	40
2.19	Writing to an almost full synchronous FIFO	41
2.20	Reading from a full synchronous FIFO	41

2.21 Reading from an almost empty synchronous FIFO	42
2.22 Writing to an empty asynchronous FIFO	43
2.23 Writing to an almost full asynchronous FIFO	43
2.24 Reading from a full asynchronous FIFO	44
2.25 Reading from an almost empty asynchronous FIFO	44
2.26 Overview of the Global Mesh signal injection	47
2.27 Clock input multiplexers CLKIN	48
2.28 phase-locked loop (PLL) wrapper with input and output clocks	48
2.29 GLBOUT multiplexers	50
2.30 Overview of signal extraction from the Global Mesh	53
2.31 Intake Cologne Programmable Element (CPE) with chained CPE row	58
2.32 Intake Bottom Edge Select (BES) with chained BES row	59
2.33 Unchained BES row with Global Mesh pick-up	60
2.34 Intake Left Edge Select (LES) with chained CPE row	61
2.35 Switch Box (SB) interconnection scheme	62
2.36 Small Switch Box	63
2.37 Big Switch Box	63
2.38 CPE connections to the routing structure	63
3.1 GateMate™ FPGA workflow	66
3.2 Power-on reset (POR) module block diagram	74
3.3 Threshold principles of POR	75
3.4 FPGA reset using the POR module	76
3.5 FPGA reset driven by an external logic	77
3.6 Configuration data from flash memory in SPI single-I/O or dual-I/O mode	80
3.7 Configuration data from flash memory in SPI quad-I/O mode	80
3.8 Configuration data stream from a single flash memory	81
3.9 Connection of CFG_DONE and CFG_FAILED_N signals in multi-FPGA applica- tions with a single flash memory	82
3.10 JTAG connection scheme	83
3.11 Finite-state machine of the JTAG interface	84
3.12 JTAG instruction shift NEW COMMAND	85
3.13 JTAG data shift	85
3.14 JTAG-SPI bypass connection scheme	86

3.15	Timing diagram of the JTAG-SPI bypass mode.	87
5.1	CCGM1A1 FBGA pinout	98
5.2	Configuration pins of CCGM1A1 FBGA pinout for use as GPIO after configuration	98
5.3	Clock input pins as second function of some GPIOs	98
6.1	FATC FBGA 324 balls package dimensions	112
7.1	Reflow soldering profile	114

List of Tables

2.1	20K configurations	28
2.2	40K configurations	28
2.3	Input signal group	29
2.4	Pin wiring in TDP 20K mode	31
2.5	Pin wiring in TDP 40K mode	32
2.6	Pin wiring in SDP 20K mode	33
2.7	Pin wiring in SDP 40K mode	33
2.8	Access combinations in NO CHANGE mode with {A B}_EN =1 (simple dual port (SDP) and true dual port (TDP))	36
2.9	Access combinations in WRITE THROUGH mode with {A B}_EN =1 (TDP only)	36
2.10	FIFO status flags	39
2.11	FIFO 40 bit data concatenations	39
2.12	FIFO 80 bit data concatenations	40
2.13	USR_PCLK<n> sources	46
2.14	CPE destinations of PLL clock output signals	49
2.15	USR_GLB[3:0] sources	50
2.16	Connecting Global Mesh signals to Switch Boxes	54
2.17	Connecting Global Mesh signals to CPEs	54
2.18	Control of the clocking scheme via CC_BUF _G and carry & propagation signal lines (CP-lines)	55
3.1	Configuration mode setup	78

3.2	Configuration signal bank	79
3.3	Configuration process state	81
4.1	Absolute maximum ratings	93
4.2	Operation range	93
4.3	GPIO characteristics in single-ended mode	94
4.4	GPIO characteristics in LVDS mode	94
4.5	PLL characteristics	95
4.6	Reset characteristics	96
5.1	Pin types	99
5.2	CCGM1A1 Pin list sorted by ball name	100
7.1	Pb-free reflow soldering profile	114

About this Document

This datasheet covers all features of the Cologne Chip GateMate™ FPGA Series and is part of the GateMate™ documentation collection.

For more information please refer to the following documents:

- [Technology Brief of GateMate™ FPGA](#)
- [DS1002 – GateMate™ FPGA Programmer Board Ver. 1.3 Datasheet](#)
- [DS1003 – GateMate™ FPGA Evaluation Board Ver. 3.1 Datasheet](#)
- [UG1001 – GateMate™ FPGA Primitives Library](#)
- [UG1002 – GateMate™ FPGA Toolchain Installation User Guide](#)

Cologne Chip provides a comprehensive technical support. Please visit our website for more information or contact our support team.

Revision History









This Datasheet is constantly updated. The latest version of the document can be found following the link below:

[DS1001 – GateMate™ FPGA CCGM1A1 Datasheet](#)

Date	Remarks
January 2023	Minor changes in Section 3.1.
December 2022	<ul style="list-style-type: none"> • Section 2.6 (Global Mesh Architecture) from page 46 added. • Section 2.7 (Clocking Schemes) from page 52 added. • SPI_CLK (pin N4) and JTAG_TCK (pin R3) are no longer available as dedicated clock input pins. • Chapter 7 (Soldering Guidelines) added. • Figure 2.2 on page 22 extended by details.
May 2022	<ul style="list-style-type: none"> • Sections 3.1.2 (Synthesis), 3.1.3 (Implementation) and 3.1.4 (Configuration) from page 67 added. • Additional explanation to the power-on reset module: <ul style="list-style-type: none"> – Section 3.2.1 from page 74 expanded. – Sections 3.2.2 and 3.2.2 from page 75 added. – Reset characteristics in Table 4.6 on page 96 added. • Clock pins renamed from CLK[4:1] to CLK[3:0] (BGA pins N14, P12, P14 and R13).
February 2022	Updated workflow description in Section 3.1.1 from page 65 with Yosys support added.
October 2021	Additional explanation to Section 2.4.8 on page 36.
July 2021	<ul style="list-style-type: none"> • Expanded Block RAM documentation in Section 2.4 from page 27. • Updated maximum PLL output frequencies in Section 2.5 on page 45.
December 2020	<ul style="list-style-type: none"> • Expanded JTAG interface documentation in Section 3.4 from page 83. • Updated package height and tolerances in Figure 6.1 on page 112.
February 2020	Initial pre-release.

General Remarks to Notations

1. The decimal point is written as a point (e.g., 1.23). Thousands separators are written with thin space.
2. Numerical values have different notations for various number systems; e.g., the hexadecimal value 0x C9 is 0b 1100 1001 in binary and 201 in decimal notation.
3. The prefix ‘kilo’ is written k for the meaning of 1000 and it is written K for the meaning of 1024.
4. Functional elements of the GateMate™ FPGA have certain colors. These are:

	Cologne Programmable Element (CPE)
	Input Multiplexer (IM)
	Output Multiplexer (OM)
	Small Switch Box (SB)
	Big Switch Box (SB)
	General purpose input / output (GPIO)
	Dual port SRAM (DPSRAM)
	Phase-locked loop (PLL)
	Serializer / Deserializer (SerDes)

5. General purpose input / output (GPIO) banks and special pin functions of the GateMate™ FPGA are grouped by certain colors. Please see Section 5.2 on page 99 for an overview.

Chapter 1

Introduction

1.1 Introduction

The Cologne Chip GateMate™ FPGA Series is a family of small to medium-sized FPGAs that addresses all requirements of typical applications. The programmable silicon can be used from low power to high speed applications and thus in a wide range of fields: industry, automation, communication, security, automotive, Internet of Things (IoT), artificial intelligence (AI), and lots more.

Logic capacity, power consumption, package size and printed circuit board (PCB) compatibility are optimized for a wide range of applications. As these FPGAs combine various features with lowest cost in the market, the devices are well suited from university projects to high volume applications. Because of the outstanding ratio of circuit size to cost, even price sensitive applications can also now take advantage of FPGAs. The devices are manufactured using Globalfoundries™ 28 nm Super Low Power (SLP) process in Dresden, Germany. The GateMate™ FPGA program is supported by the German Federal Ministry for Economic Affairs and Energy as part of the Important Project of Common European Interest (IPCEI) on Microelectronics project, which is also supported by the European Commission.

Cologne Chip is a semiconductor company based in Cologne, Germany. The company, which celebrates its 25th anniversary in 2020, has excellent industry knowledge and an experienced team of developers. The design and manufacturing location *Made in Germany* represents a unique selling proposition of globally competitive FPGAs in the market.

Supported by:



on the basis of a decision
by the German Bundestag

Cologne Chip offers and supports a variety of development tools:

- The GateMate™ FPGA Evaluation Board is a feature-rich, ready-to-use development platform that serves as a reference design and for a direct entry into application development.
- With the help of the GateMate™ FPGA Programmer, the FPGA can be configured in various ways.

Cologne Chip provides a comprehensive technical support. Please visit our website for more information or contact our support and sales teams.

1.2 Features

- Novel programmable element architecture
 - 20,480 programmable elements for combinatorial and sequential logic
 - 20,480 8-input LUT-trees / 40,960 4-input LUT-trees
 - 40,960 Latches / Flip-flops within programmable elements
 - Each programmable element configurable as:
 - 1-bit full adder
 - 2-bit full adder or
 - 2×2-bit multiplier
 - Dedicated logic and routing for fast arithmetic and arbitrary-sized multipliers
- 9 general purpose input / output (GPIO) banks
 - 162 user-configurable GPIOs
 - All GPIOs configurable as single-ended or LVDS differential pairs
 - Double data rate (DDR) registers in I/O cells
 - I/O voltage range from 1.2 to 2.5 V
- 4 clock generators (PLL)
 - Maximum PLL output frequency from 250 MHz to 416.75 MHz
- 2.5 Gb/s Serializer / Deserializer (SerDes) controller
- Flexible memory resources
 - 1,310,720 total RAM bits distributed over 32 SRAM blocks
 - Each RAM block configurable as two independent 20 Kbit blocks or single 40 Kbit block
 - Simple or True Dual Port (SDP / TDP) or FIFO mode
 - Data width from 1 bit up to 40 bits (TDP) or 80 bits (SDP)
 - Bit-wide write enable
 - Error checking and correcting (ECC) for certain bit widths
- Flexible device configuration

- Configuration bank switchable to user I/O
- JTAG interface with bypass to SPI interface
- Active / passive SPI interface for single-, dual- and quad-mode operation
- SPI flash interface in active mode
- Multi-chip configuration from single source
- Application modes: *low power, economy, speed*
 - Mode adjustable on each chip via core voltage
 - Core voltage range from 0.9 to 1.1V
- Package
 - 15×15 mm 324 balls 0.8 mm fine pitch Ball Grid Array (FBGA) package
 - Only 2 signal layers required on PCB

Chapter 2

Architecture

2.1 GateMate™ FPGA Overview

The basic functional elements of GateMate™ FPGA are set up in an array structure of 160×128 elements called Cologne Programmable Element (CPE) as described in Section 2.2.

All CPEs are interconnected by a routing structure of 132×164 so-called Switch Boxes (SBs) as described in Section 2.8.

Additional functional blocks are dual port SRAMs (DPSRAMs), phase-locked loops (PLLs), general purpose input / output (GPIO) cells, SPI configuration and data flash interface, JTAG interface and Serializer / Deserializer (SerDes) interface.

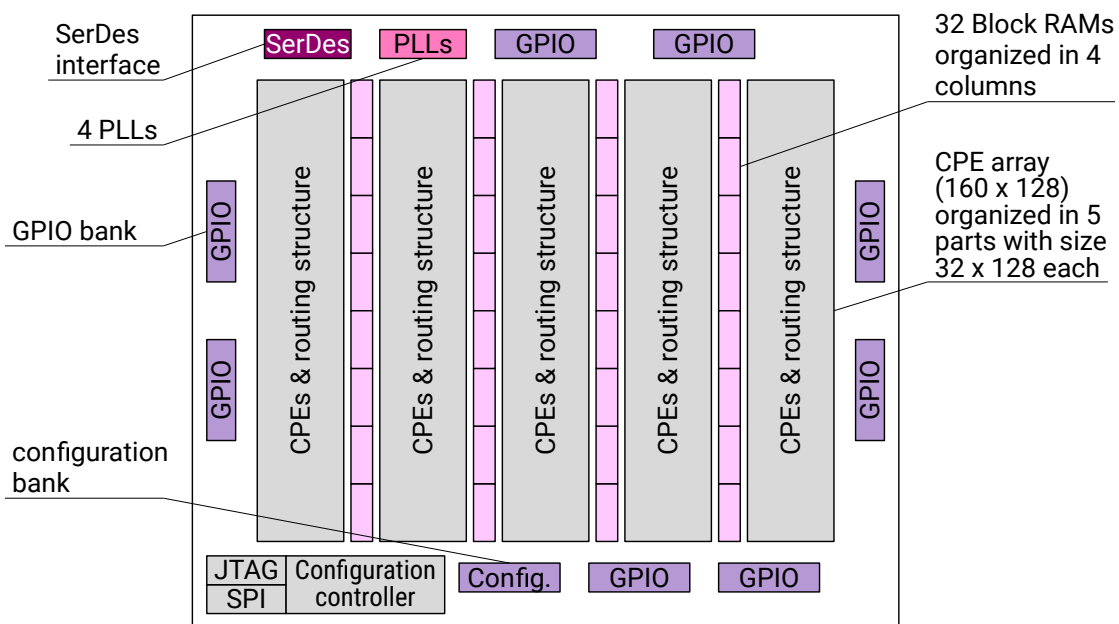

Figure 2.1: Simplified architecture overview

2.2 Cologne Programmable Element (CPE)

General purpose combinatorial and sequential circuits are implemented using CPEs. The CCGM1A1 has 20,480 CPEs arranged in a 160×128 matrix. Each CPE can be set up to the following combinatorial functions:

- Dual 4 inputs with 2-input lookup table (LUT-2) tree each
- 8 inputs with LUT-2 tree
- 6 inputs with 4-input multiplexer (MUX-4) function
- 1-bit or 2-bit full adder, expandable to any length in horizontal or vertical arrangement
- 2×2 -bit multiplier, expandable to any multiplier size

Figure 2.2 illustrates the general structure of a CPE. General combinatorial and sequential functions are supported from fast signal path routing. In addition, the DPSRAM blocks of GateMate™ FPGA, as described in Chapter 2.4, require some CPE ports $RAM_I[2:1]$ and $RAM_O[2:1]$ for CPE-to-SRAM connection.

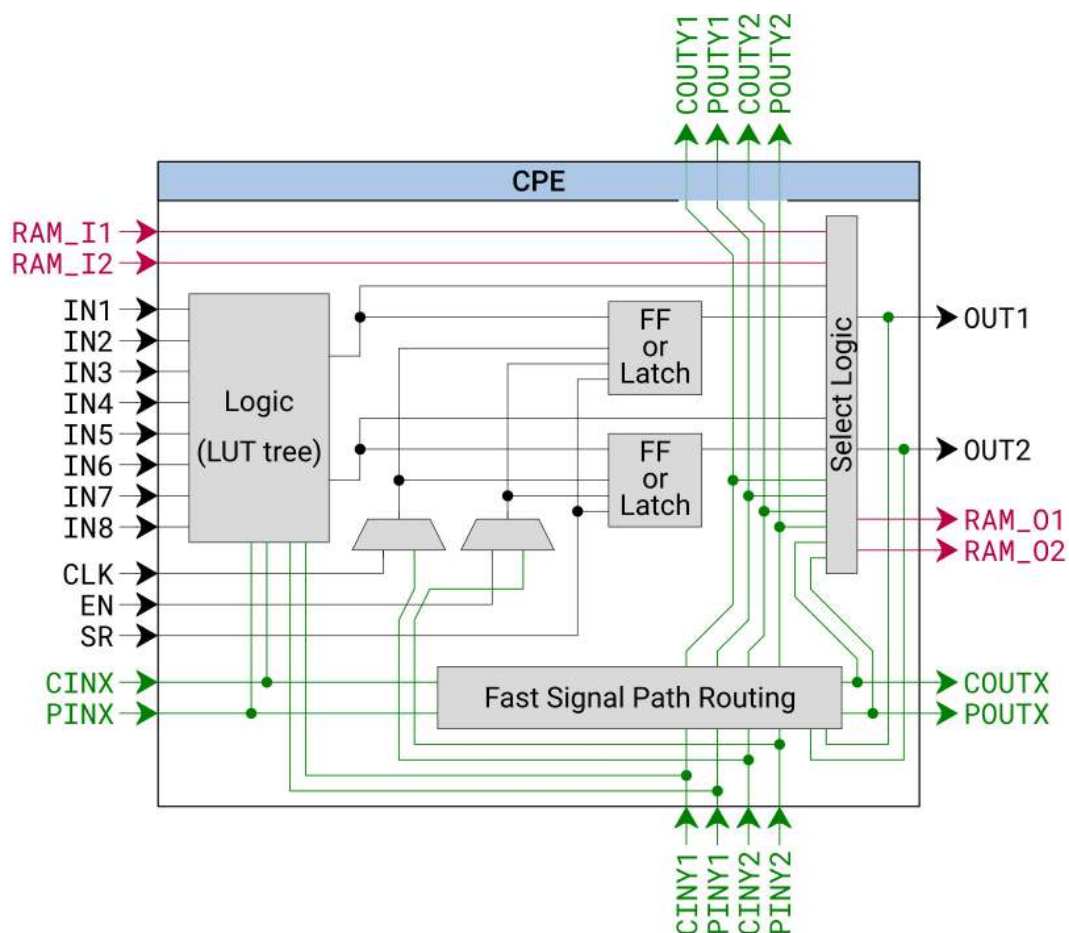

Figure 2.2: Cologne Programmable Element (CPE)

Two CPE outputs OUT1 and OUT2 are available and each can use a Flip-Flop or Latch function.

Furthermore, the CPEs include fast signal routing paths, so-called carry & propagation signal lines (CP-lines). Typically, they are used for fast clock and carry propagation in adder and multiplier functions, e.g., fast CPE to adjacent CPE connections, or even fast signal propagation over any span of CPEs.

2.3 General purpose input / output (GPIO)

The GateMate™ FPGA offers up to 162 general purpose input / output pins (GPIOs). These are organized in signal pairs, so-called *pad cells*, which can either operate as two independent, bidirectional single-ended signals or they can be set up as bidirectional low-voltage differential signaling (LVDS). Figures 2.3 and 2.4 show the structure of the pad cells and their interconnection to the FPGA elements.

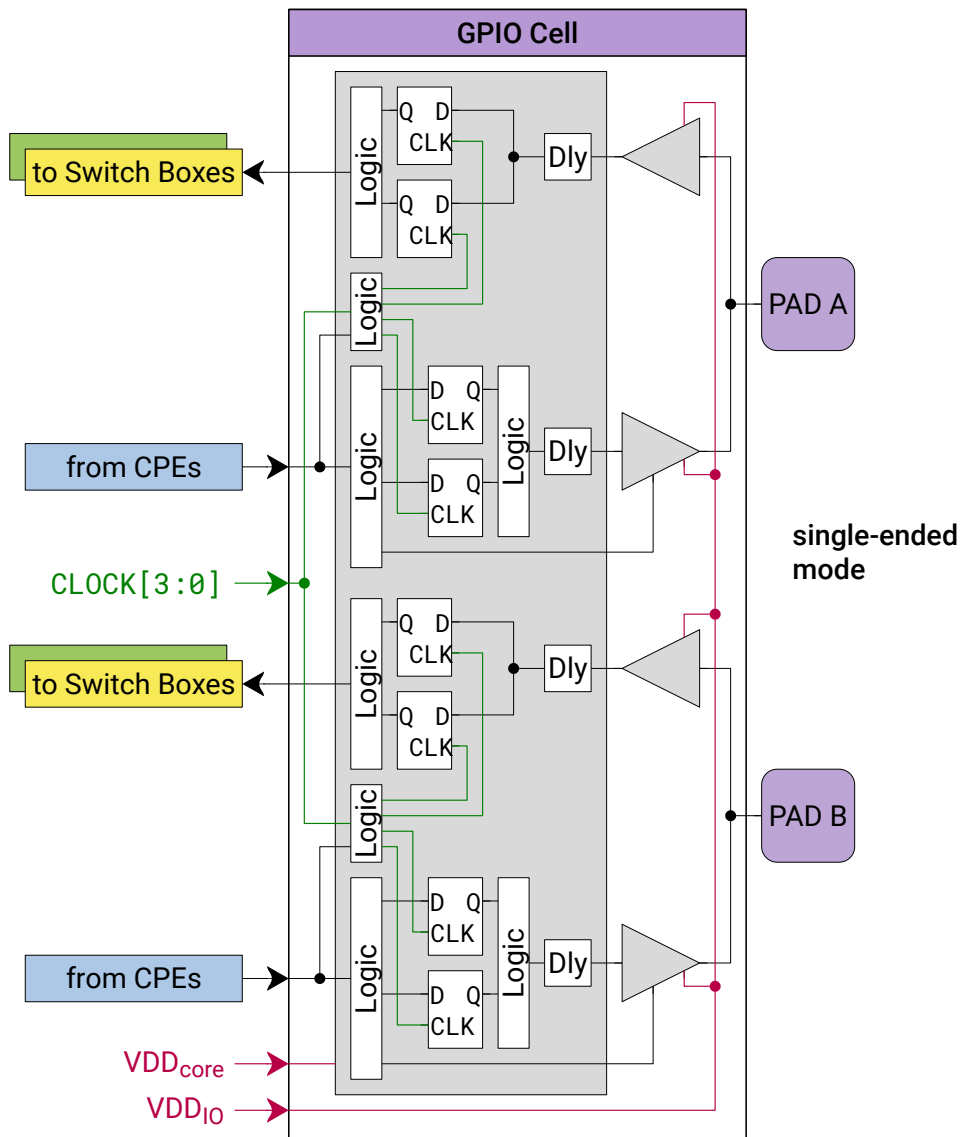

Figure 2.3: GPIO cell in single-ended mode

Nine pad cells build up a GPIO bank as shown in Figure 2.5 on page 26. Eight banks and another optional bank¹ are available.

¹ The FPGA configuration pins are arranged within the ninth GPIO bank. These pins can be used as normal GPIO bank after configuration process.

The single-ended GPIO support the low voltage CMOS (LVCMOS) standard up to 2.5V nominal supply voltage, compliant to the standards JESD8-5 (2.5V) and JESD8-7 (1.8V and 1.2V).

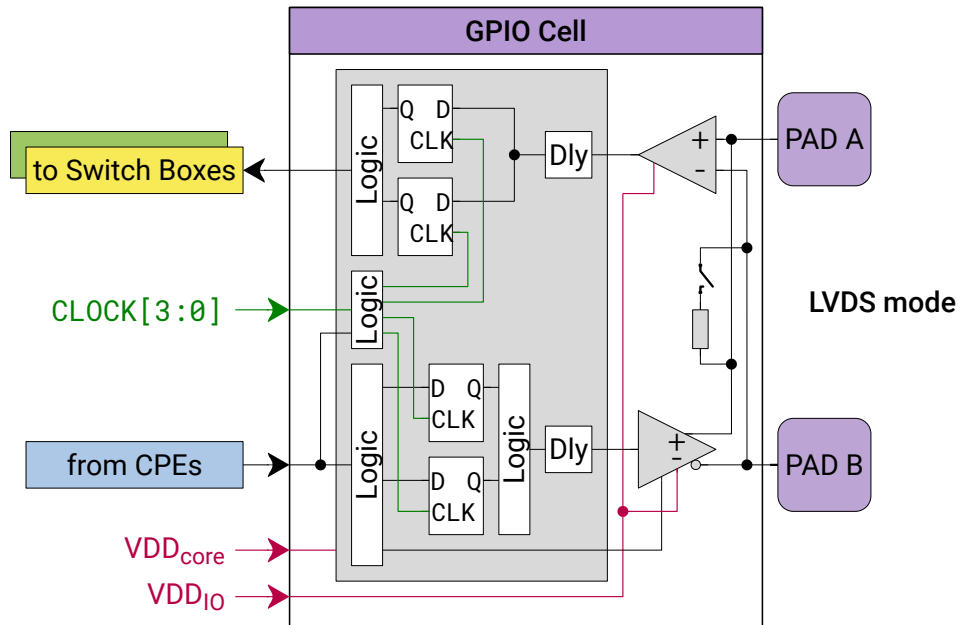

Figure 2.4: GPIO cell in LVDS mode

The single-ended GPIO pins have the following output features:

- 0/1/high-Z
- Slew-rate control
- Driver strength 3 mA, 6 mA, 9 mA and 12 mA
- 2 Flip-Flops
- Programmable delay line

The single-ended GPIO pins have the following input features:

- Schmitt-trigger input
- Pull-up / pull-down resistors or keeper functionality
- Input receiver disable for power reduction
- 2 Flip-Flops
- Programmable delay line

If a pad cell is used in its LVDS mode, both pads can be used together only. The LVDS pad is compliant to the LVDS 2.5V standard. It further can operate down to 1.8V nominal supply voltage, with common mode voltage $V_{DD}/2$. The LVDS input receiver can be used as voltage comparator.

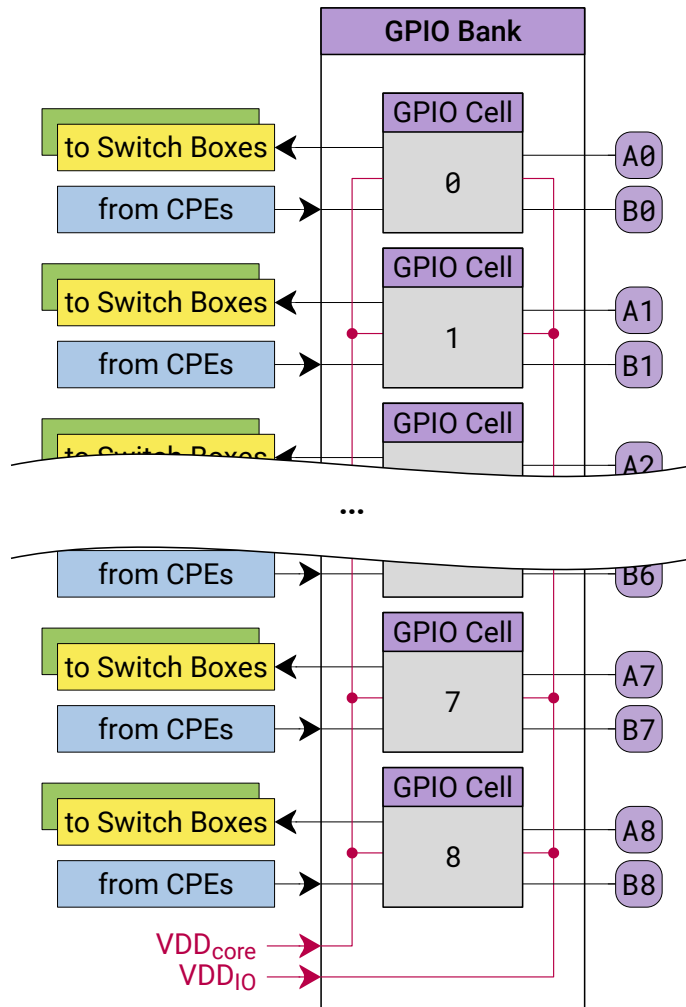

Figure 2.5: GPIO bank

2.4 Embedded Block RAM

2.4.1 Block RAM Overview

The GateMate™ FPGA contains a number of embedded volatile memory cells which are organized as configurable 40 kbit dual port SRAM (DPSRAM) cells. These random-access memory (RAM) cells are arranged in columns between the CPE array and routing structure as illustrated in Figure 2.6. Block RAMs have an address (x, y) with $x = 0..3$ and $y = 0..7$.

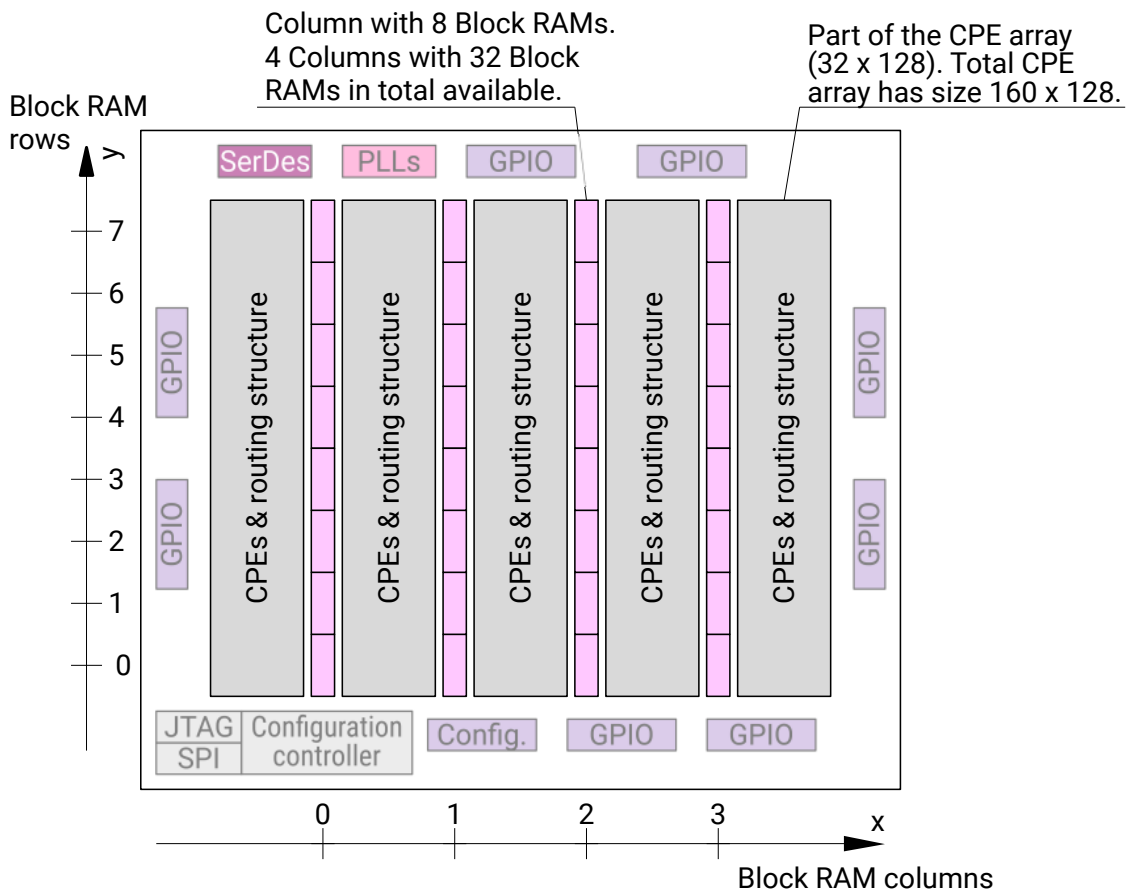

Figure 2.6: Block RAM arrangement

Each Block RAM cell can be configured as a single 40K or two independent 20K DPSRAM cells. Both allow usage of the memory in true dual port (TDP) or simple dual port (SDP) mode.

The GateMate™ Block RAM features include:

- Data widths from 1 bit up to 40 bits in TDP mode or 80 bits in SDP mode.
- Bit-wide write enable allows a bit-wise writing of incoming data and can be used when for example interfacing with a microprocessor.

- Each port has optional output registers. When enabled, validity of the output data gets delayed by one clock cycle. This feature is particularly helpful when dealing with critical paths.
- Each port provides an error checking and correcting (ECC) module for data protection against unintended changes. Error correction is able to correct one bit errors and detect two bit errors.
- A memory cascading feature connects adjacent RAM cells to form a larger array. This feature enables the instantiation of deeper or wider memories and a flexible forwarding of clocks, address and control signals.
- Two adjacent Block RAMs can be combined to one deeper 64K × 1 memory by extending the cascade feature to forward data and bitmask signals as well.
- Contents of the Block RAM cells can be initialized during configuration, e.g., to build read-only memory (ROM).
- All clock, enable and write enable signals can be inverted individually.
- Each Block RAM can be used as a first-in, first-out memory (FIFO) in asynchronous or synchronous mode with dedicated status signals for FIFO monitoring and reset.

Tables 2.1 and 2.2 show the available address and data bus width configurations as well as the ECC availability for both 20K and 40K configurations in SDP and TDP modes.

Table 2.1: 20K configurations

Configuration	TDP	SDP	ECC
(RAM size per 20K block)			
16K × 1 bit	✓	✓	✗
8K × 2 bit	✓	✓	✗
4K × 5 bit	✓	✓	✗
2K × 10 bit	✓	✓	✗
1K × 20 bit	✓	✓	✗
512 × 40 bit	✗	✓	✓

Table 2.2: 40K configurations

Configuration	TDP	SDP	ECC
32K × 1 bit	✓	✓	✗
16K × 2 bit	✓	✓	✗
8K × 5 bit	✓	✓	✗
4K × 10 bit	✓	✓	✗
2K × 20 bit	✓	✓	✗
1K × 40 bit	✓	✓	✓
512 × 80 bit	✗	✓	✓

2.4.2 Block RAM Architecture

A Block RAM cell has a maximum storage capacity of 40 Kbits and can be configured as a single 40K cell or two independent 20K cells. It contains two independent ports A and B that are implemented in the form of the four input signal groups A0, B0, A1 and B1. Configured as two independent 20K cells, A0, B0, A1 and B1 represent ports A and B for the two cells. In the 40K configuration, A0+A1 and B0+B1 are combined to represent both ports A and B. Figure 2.7 shows the basic structure of a single Block RAM cell with its horizontal input and output connections from the CPE array and to the routing structure as well as the vertical interconnection to adjacent Block RAM cells.

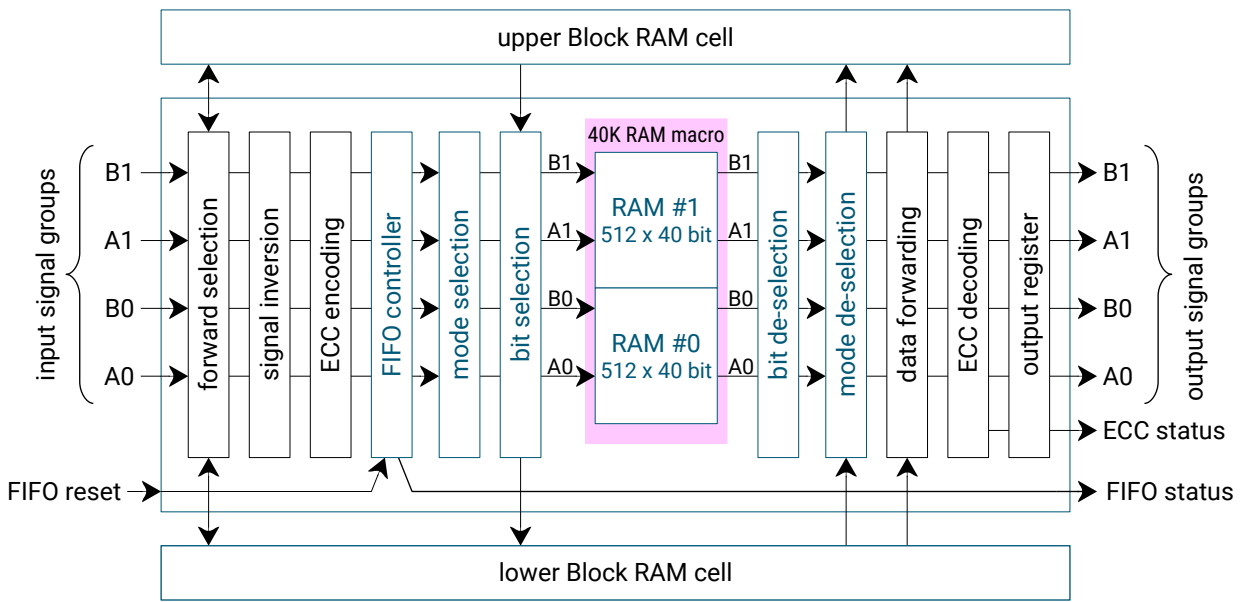

Figure 2.7: High level block diagram of a block RAM cell

The memory inputs can each be fed in from the CPE outputs RAM_01 or RAM_02. Each of the control and address signals CLK, EN, WE and ADDR can be selected from two input connections.

Table 2.3: Input signal group

Signals	Width	Description
{a0, a1, b0, b1}_clk{1, 2}	1	Clock signal
{a0, a1, b0, b1}_en{1, 2}	1	Enable signal
{a0, a1, b0, b1}_we{1, 2}	1	Write enable signal
{a0, a1, b0, b1}_addr{1, 2}	16	Address bus
{a0, a1, b0, b1}_di	20	Data bus
{a0, a1, b0, b1}_bm	20	Mask for bit-wise write enable

Data output signals and status output signals such as ECC and FIFO flags are connected via the CPE inputs RAM_I1 and RAM_I2 to the Switch Boxes (SBs) of the routing structure.

The entire functionality of the Block RAM is implemented over several layers around the RAM cores. The forward selection part allows a flexible switching between several incoming signals of which one can be selected and forwarded to the next layers. This corresponds to the clock, enable, write enable, address, data and bitmask signals. The forward selection determines whether signals (a) from an adjacent RAM cell, e.g., to allow the building of wider or deeper memories, or (b) from the CPE array via the input signal groups A0, A1, B0 and B1 are routed to the next layers.

In the signal inversion block the clock, enable and write enable signals are individually

inverted depending on the configuration.

The Block RAM provides an internal ECC encoding and decoding layer to protect data against corruption. Depending on the configuration, 8 or 16 bits are required for storage of the parity bits. This feature is therefore only available for data widths of 40 or 80 bits as shown in Tables 2.1 and 2.2. Due to the storage of the parity bits, the actual net data width is 32 or 64 bits. Error correction is implemented using Hamming-code (39,32) with 7 parity bits. It can correct one bit error and detect two bit errors. The error status can be queried via the corresponding output signals. Section 2.4.7 describes the ECC features in more detail.

With the FIFO feature enabled, the internal write and read pointers will be forwarded to the memory macros. The address signals are therefore ignored. Port B is the push while port A is the pop side. The FIFO is configurable to be synchronous or asynchronous. Additional flags indicate the current status, such as empty, full, almost empty, almost full, read error, write error as well as the current FIFO read and write pointers. Moreover, the FIFO controller has a dedicated active low reset signal FIFO_RST_N. Section 2.4.9 describes the FIFO features in more detail.

The mode selection part forwards the incoming signals of ports A0, A1, B0 and B1 to the 8 ports of the memory hard macros according to the selected mode. Sections 2.4.3 and 2.4.4 describe the TDP and SDP modes in more detail.

Each port has an optional output register to improve design performance. If enabled, validity of the output data and ECC status flags get registered and thus delayed by one clock cycle.

2.4.3 TDP Mode

Block RAM in true dual port (TDP) mode supports simultaneous read and write operations and has two independent access ports. Figures 2.8 and 2.9 illustrate the TDP data flow in both 20K and 40K configurations.

Data can be read to or written from both ports at the same time. Read access to one port while writing to the other is also possible. Both ports can have separate clocks and input and output data widths may be different. Thus, the clocks can be synchronous or asynchronous. Both ports have access to the entire memory at any time.

There is no internal conflict handling when accessing the same address at the same time. Such simultaneous accesses can result in data uncertainty and should be avoided.

If split into two independent 20K cells, the maximum data width per port is 20 bits. In the 40K configuration, the maximum data width per port is 40 bits.

Table 2.4 shows the data and address bus wiring in TDP 20K mode when using half Block RAM #0. Control signals are a0_clk, a0_en and a0_we. The wiring of a0_di also applies to the a0_bm signals. The wiring for the other half Block RAM #1 ports A1 and B1 is equivalent.

Table 2.5 shows the data and address bus wiring in TDP 40K mode when using ports A0 and A1 to form port A. Control signals are a0_clk, a0_en and a0_we. Note that due to

Data width: $n_d = 1 \dots 20$
 Address width: $n_a = 0 \dots 5$

Separate values n_d and n_a for ports A and B as well as for data read and write accesses.

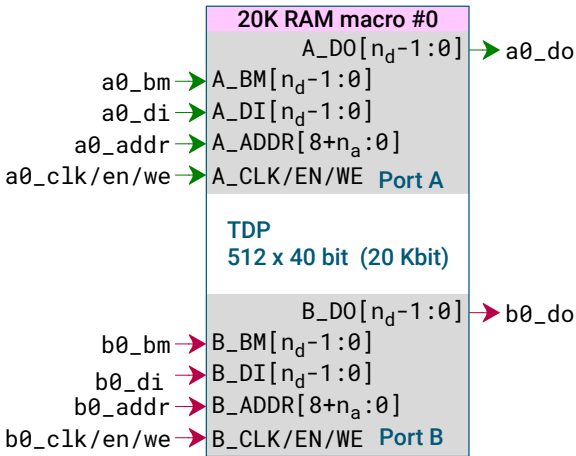

Same for RAM #1, where all signals $a0_*$ and $b0_*$ are $a1_*$ and $b1_*$.

Figure 2.8: Internal data flow of DPSRAM in TDP 20K mode

Data width: $n_d = 1 \dots 40$
 Address width: $n_a = 0 \dots 6$

Separate values n_d and n_a for ports A and B as well as for data read and write accesses.

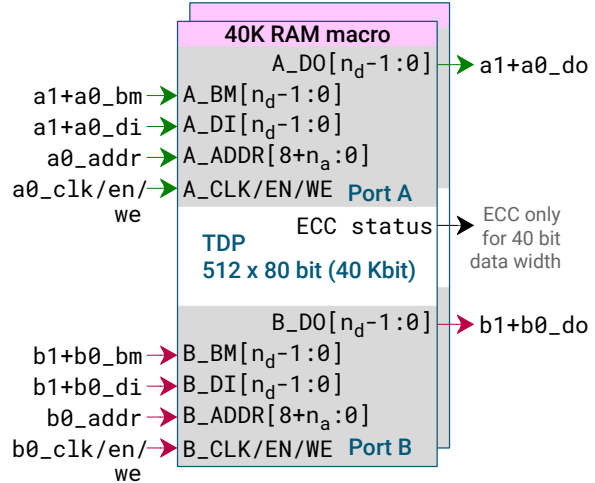

Figure 2.9: Internal data flow of DPSRAM in TDP 40K mode

the port combining, the maximum data width per port is 40 bits. The wiring of $a0_di$ also applies to the $a0_bm$ signals. The wiring for port B, which is formed by B0 and B1, is equivalent.

2.4.4 SDP Mode

Block RAM in simple dual port (SDP) mode supports simultaneous read and write operations, but has a single output port for read data. By that, data widths can be doubled compared to the TDP mode.

Table 2.4: Pin wiring in TDP 20K mode

Width	Depth	Address-in bus ¹	Data-in bus ¹	Data-out bus ¹
1	16,384	$a0_addr[15:7] \circ a0_addr[5:1]$	$a0_di[0]$	$a0_do[0]$
2	8,192	$a0_addr[15:7] \circ a0_addr[5:2]$	$a0_di[1:0]$	$a0_do[1:0]$
5	4,096	$a0_addr[15:7] \circ a0_addr[5:3]$	$a0_di[4:0]$	$a0_do[4:0]$
10	2,048	$a0_addr[15:7] \circ a0_addr[5:4]$	$a0_di[9:0]$	$a0_do[9:0]$
20	1,024	$a0_addr[15:7] \circ a0_addr[5]$	$a0_di[19:0]$	$a0_do[19:0]$

¹ Symbol \circ is concatenation.

Data width: $n_d = 1 \dots 20$ (1 .. 40 bits)
 Address width: $n_a = 0 \dots 5$
 Separate values n_d and n_a for ports A and B.

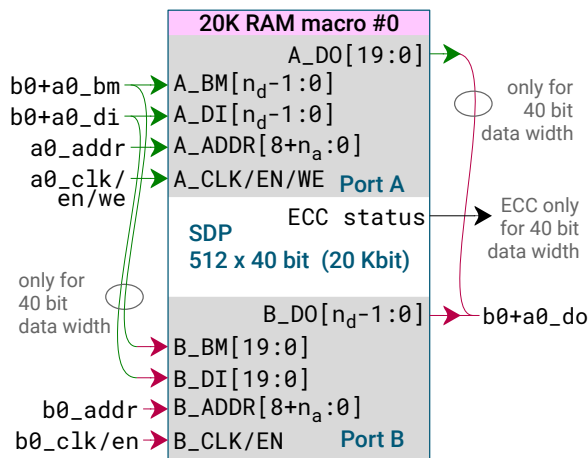

Same for RAM #1, where all signals $a0_*$ and $b0_*$ are $a1_*$ and $b1_*$.

Figure 2.10: Internal data flow of DPSRAM in SDP 20K mode

Data width: $n_d = 1 \dots 40$ (1 .. 80 bits)
 Address width: $n_a = 0 \dots 6$
 Separate values n_d and n_a for ports A and B.

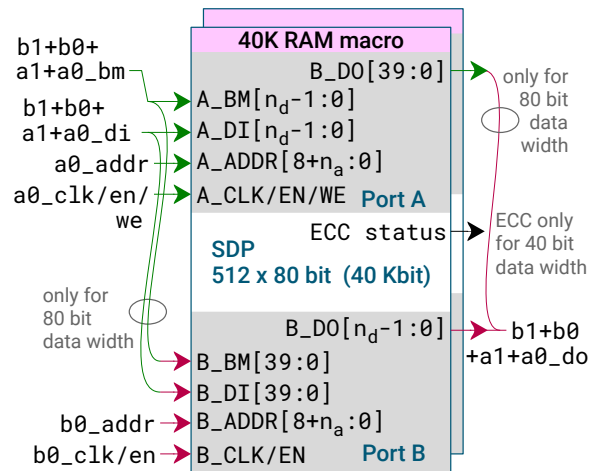

Figure 2.11: Internal data flow of DPSRAM in SDP 40K mode

Port A is always the write port, while port B is always the read port. Both write and read ports can have separate clocks. The write port A uses the enable signal $\{a0, a1\}_en$ and write enable signal $\{a0, a1\}_we$ for write access and the read port B uses only the enable signal $\{b0, b1\}_en$ for read access.

Table 2.6 shows the data and address bus wiring in SDP 20K mode. By combining the data buses on ports A0 and B0, the maximum bus width can be doubled compared to the TDP mode. Control signals for the write port A are $a0_clk$, $a0_en$ and $a0_we$. Control signals for the read port B are $b0_clk$ and $b0_en$. The wiring of $\{a0, b0\}_di$ also applies to the $\{a0, b0\}_bm$ signals. The wiring for ports A1 and B1 is equivalent.

Table 2.5: Pin wiring in TDP 40K mode

Width	Depth	Address-in bus	Data-in bus ¹	Data-out bus ¹
1	32,768	$a0_addr[15:1]$	$a0_di[0]$	$a0_do[0]$
2	16,384	$a0_addr[15:2]$	$a0_di[1:0]$	$a0_do[1:0]$
5	8,192	$a0_addr[15:3]$	$a0_di[4:0]$	$a0_do[4:0]$
10	4,096	$a0_addr[15:4]$	$a0_di[9:0]$	$a0_do[9:0]$
20	2,048	$a0_addr[15:5]$	$a0_di[19:0]$	$a0_do[19:0]$
40	1,024	$a0_addr[15:6]$	$a1_di[19:0]$ $\circ a0_di[19:0]$	$a1_do[39:0]$ $\circ a0_do[39:0]$

¹ Symbol \circ is concatenation.

Table 2.7 shows the data and address bus wiring in SDP 40K mode. By combining the data buses on all ports A0, B0, A1 and B1, the maximum bus width can be doubled compared to the TDP mode. Control signals for the write port A are A0_CLK, A0_EN and A0_WE. Control signals for the read port B are b0_clk and b0_en. The wiring of {a0, a1, b0, b1}_di also applies to the {a0, a1, b0, b1}_bm signals.

2.4.5 Expanding Data Widths and Cascade Mode

The Block RAM allows the coupling of adjacent Block RAMs to build larger or deeper memories by forwarding clock, enable, write enable and address signals. This feature facilitates the routing in the CPE array and the routing structure for the signals mentioned.

The cascade mode extends this feature by forwarding data and bitmask as well. It only allows a data width of 1 bit. Cascading is only possible in the lower direction, as shown in Figure 2.12 on page 34. By that, two adjacent $32K \times 1$ bit Block RAM cells can be combined to form a $64K \times 1$ bit memory. The actual data and bitmask inputs and outputs of the cascade are the data and bitmask inputs and outputs of the upper RAM cell. Prerequisite is that both RAM cells involved are configured in $32K \times 1$ bit TDP mode. Bit 0 of the address bus selects the upper or lower Block RAM cell for the write or read operation.

2.4.6 Memory Mapping and Content Initialization

Each port can access a certain memory area depending on its configuration. The addressing scheme depends on the configuration mode. Words of 5, 10, 20, 40 and 80^2 bits are

Table 2.6: Pin wiring in SDP 20K mode

Width	Depth	Address-in bus	Data-in bus ¹	Data-out bus ¹
40	512	{b0, b0}_addr[15:7]	b0_di[19:0] ◦ a0_di[19:0]	b0_do[19:0] ◦ a0_do[19:0]

¹ Symbol ◦ is concatenation.

Table 2.7: Pin wiring in SDP 40K mode

Width	Depth	Address-in bus	Data-in bus ¹	Data-out bus ¹
80	512	{b0, a0}_addr[15:7]	b1_di[19:0] ◦ b0_di[19:0] ◦ a1_di[19:0] ◦ a0_di[19:0]	b1_do[19:0] ◦ b0_do[19:0] ◦ a1_do[19:0] ◦ a0_do[19:0]

¹ Symbol ◦ is concatenation.

² Data width of 80 bits only supported in 40K SDP mode (see Tables 2.1 and 2.2).

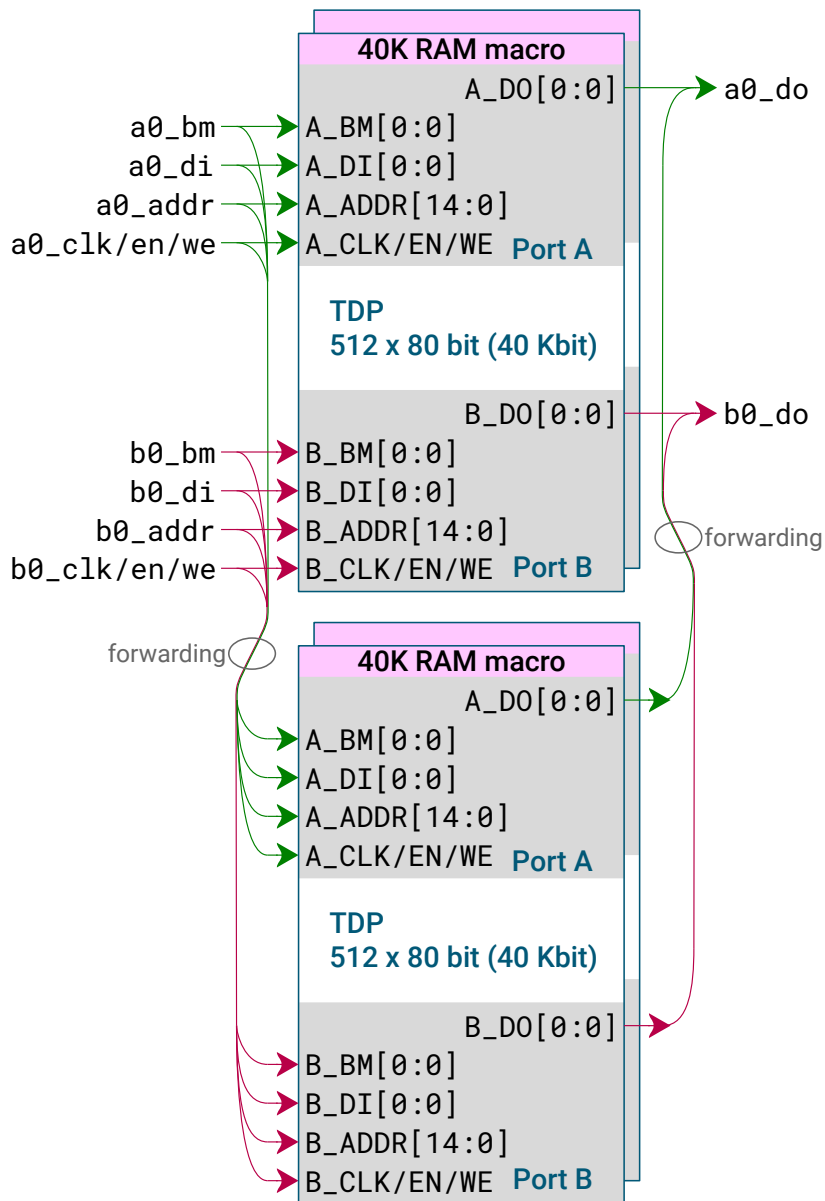

Figure 2.12: Structure of two adjacent DPSRAMs forming one 64K x 1 bit memory via cascade feature

distributed equally over all four static random-access memory (SRAM) blocks whereas 1 and 2 bit wide words are arranged so that every 5th bit is not accessible. This leads to a logical mapping of the memory bits as shown in Figure 2.13 on page 35. The scheme shown here can be applied to both SDP and TDP modes in 20K as well as in 40K configurations.

2.4.7 ECC Encoding / Decoding

The Block RAM cell provides an internal ECC encoding and decoding layer to protect data against corruption. If configured, parity bits are generated and checked automatically. Using this feature, the user cannot utilize the all 40 or 80 data bits but must restrict to

Port Width	Logical Mapping																																							
1 Bit	x	63	62	61	60	x	59	58	57	56	x	55	54	53	52	x	51	50	49	48	x	47	46	45	44	x	43	42	41	40	x	39	38	37	36	x	35	34	33	32
2 Bits	x	31	30	x	29	28	x	27	26	x	25	24	x	23	22	x	21	20	x	19	18	x	17	16																
5 Bits	15				14				13				12				11				10				9				8											
10 Bits	7								6								5								4															
20 Bits	3																2																							
40 Bits	1																																							
80 Bits	0																																							
Bit Location	19	18	17	16	15	14	13	12	11	10	9	8	7	6	5	4	3	2	1	0	19	18	17	16	15	14	13	12	11	10	9	8	7	6	5	4	3	2	1	0
	Dual Port SRAM #1 – 512 x 40 bit																																							
1 Bit	x	31	30	29	28	x	27	26	25	24	x	23	22	21	20	x	19	18	17	16	x	15	14	13	12	x	11	10	9	8	x	7	6	5	4	x	3	2	1	0
2 Bits	x	15	14	x	13	12	x	11	10	x	9	8	x	7	6	x	5	4	x	3	2	x	1	0																
5 Bits	7				6				5				4				3				2				1				0											
10 Bits	3								2								1								0															
20 Bits	1																0																							
40 Bits	0																																							
80 Bits	0																																							
Bit Location	19	18	17	16	15	14	13	12	11	10	9	8	7	6	5	4	3	2	1	0	19	18	17	16	15	14	13	12	11	10	9	8	7	6	5	4	3	2	1	0
	Dual Port SRAM #0 – 512 x 40 bit																																							

x Bit not accessible

Figure 2.13: Logical data mapping of memory at physical address 0

32 or 64 bits since the remaining 8 or 16 bits are required for storage of parity bits. This feature is only available for the following configurations:

- TDP 40K, configured to 40 bits of which user can only use 32 bits
- SDP 40K, configured to 80 bits of which user can only use 64 bits
- SDP 20K, configured to 40 bits of which user can only use 32 bits

In any case the bitmask is ignored, all 32 or 64 bits plus parity are written to memory. For error correction the Hamming-code (39,32) with 7 parity bits is used. It can correct one bit error and detect two bit errors. If one error was detected the ECC single error flag signal will be logic true. If two errors were detected the ECC double error flag will be logic true. There are two dedicated status signals {A, B}_ECC_{1B, 2B}_ERR for single and double error flags each, which are utilized in the following way:

- TDP 40K, data width 40 bits: status signal A_ECC_{1B, 2B}_ERR indicate errors at port A while B_ECC_{1B, 2B}_ERR indicate errors at port B
- SDP 40K, data width 80 bits: status signal A_ECC_{1B, 2B}_ERR indicate errors while B_ECC_{1B, 2B}_ERR are don't care
- SDP 20K, data width 40 bits: status signal A_ECC_{1B, 2B}_ERR indicate errors at half Block RAM #0 while B_ECC_{1B, 2B}_ERR indicate errors at half Block RAM #1

2.4.8 RAM Access Modes and Enable

A block RAM cell has three signals to control read and write access. $\{A|B\}_{EN}$ is a global enable signal. It is required to be active during any read or write access. $\{A|B\}_{WE}$ is a global write enable signal that operates in association with the bit-wise write enable vector $\{A|B\}_{BM}$.

Data is only written to the RAM if $\{A|B\}_{EN}$, $\{A|B\}_{WE}$ and the corresponding bitmask $\{A|B\}_{BM}$ are active. Reading of data depends on the selected access mode and the values of $\{A|B\}_{WE}$ and $\{A|B\}_{BM}$. The address modes are listed in Table 2.8 and 2.9. They show all combinations of $\{A|B\}_{EN}$, $\{A|B\}_{WE}$ and $\{A|B\}_{BM}$ in both modes NO CHANGE and WRITE THROUGH as well as the resulting actions.

Table 2.8: Access combinations in NO CHANGE mode with $\{A|B\}_{EN} = 1$ (SDP and TDP)

$\{A B\}_{WE}^1$	$\{A B\}_{BM}[i]$	Action on memory and $\{A B\}_{DO}$
0	0	Single read, no update on mem[addr][i]
1	0	Last read, no update on mem[addr][i]
0	1	Single read, no update on mem[addr][i]
1	1	Last read, with update on mem[addr][i]

¹ Only A_WE in SDP mode.

Table 2.9: Access combinations in WRITE THROUGH mode with $\{A|B\}_{EN} = 1$ (TDP only)

$\{A B\}_{WE}$	$\{A B\}_{BM}[i]$	Action on memory and $\{A B\}_{DO}$
0	0	Single read, no update on mem[addr][i]
1	0	Single read, no update on mem[addr][i]
0	1	Single read, no update on mem[addr][i]
1	1	Write through, with update on mem[addr][i]

A single read access without any write operation occurs always if the enable signal is active ($\{A|B\}_{EN} = 1$) and all write enable signals are inactive ($\{A|B\}_{BM} = 0$, $\{A|B\}_{WE} = 0$). A single read access is supported in both modes SDP and TDP as shown in Figure 2.14.

All RAM cells can be initialized during configuration and used as read-only memory (ROM). To use the ROM mode the write enable has to be set to zero. The memory mapping for initialization is described in Section 2.4.6.

The NO CHANGE mode is a plain write access with active global enable ($\{A|B\}_{EN} = 1$) and write enable signals ($\{A|B\}_{BM} \geq 1$ or $\{A|B\}_{WE} = 1$). The output remains the last read data, i.e. after a single read, and is not affected by a write access. A NO CHANGE access is supported in both modes SDP and TDP as shown in Figure 2.15.

A read first access can be carried out in two clock cycles by first reading a word and then performing a write access in the following cycle.



Figure 2.14: Timing diagram of a single read access with optional (*) output register

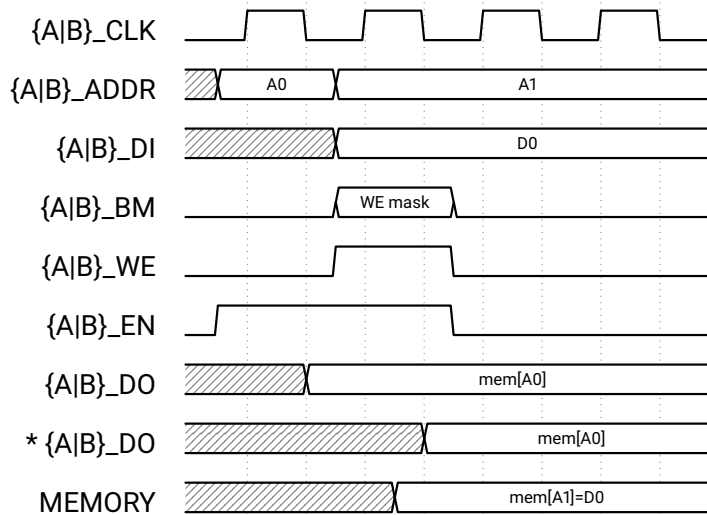

Figure 2.15: Timing diagram of a NO CHANGE access with optional (*) output register

The timing diagram 2.16 illustrates the WRITE THROUGH access, which is a simultaneous write and read access with active global enable ($\{A|B\}_EN = 1$) and write enable signals ($\{A|B\}_BM \geq 1$ or $\{A|B\}_WE = 1$). New data is written into the memory and simultaneously propagated to the outputs, also known as a transparent write. WRITE THROUGH is only supported in TDP mode.

2.4.9 FIFO Application

Each GateMate™ block RAM cell has an integrated synchronous and asynchronous FIFO controller, allowing usage of a block RAM cell as FIFO memory in the 40K configurations only.

Port B is the write / push port of the FIFO and port A is the read / pop port. In case of syn-

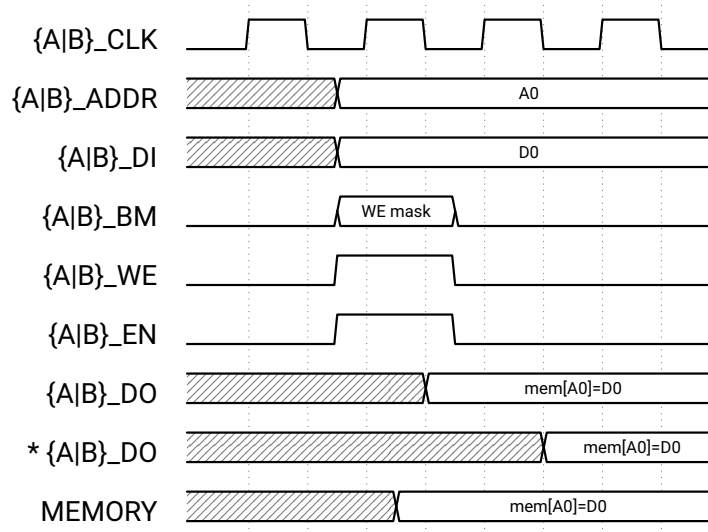

Figure 2.16: Timing diagram of a WRITE THROUGH access with optional (*) output register

chronous FIFO, A_CLK is used as clock for both write / push and read / pop.

Since the FIFO mode is an extension to the TDP / SDP 40K mode, it supports the same bitwidth configurations as shown in Tables 2.5 (page 32) and 2.7. Widths of the input and output buses must be equal.

- TDP 40K, with arbitrary but equal input and output bit width
- SDP 40K, with fixed 80 bit input and output bit width

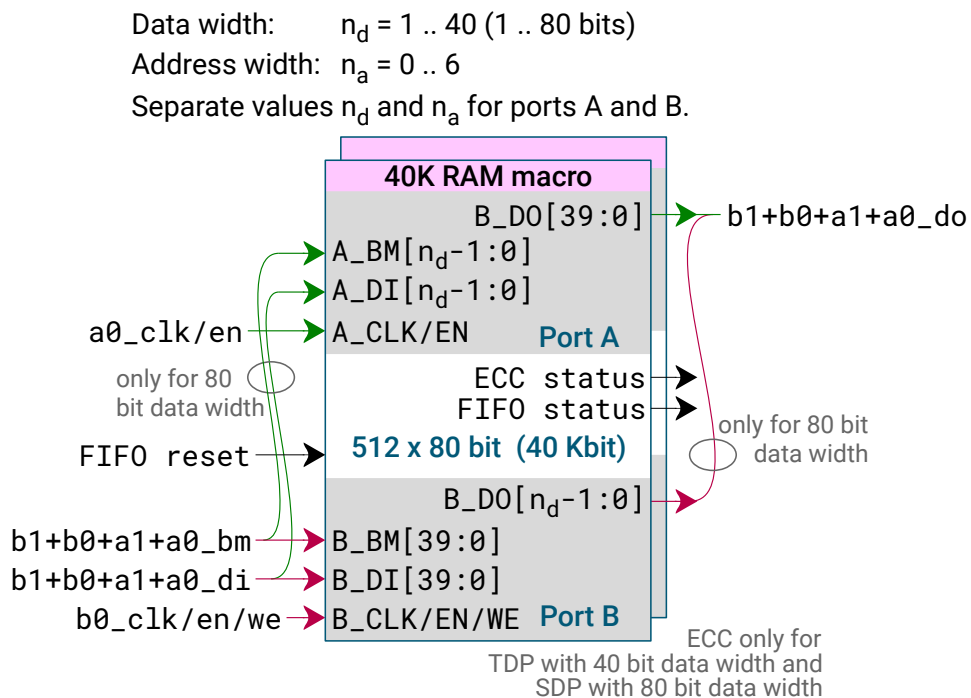

Figure 2.17: Internal data flow of DPSRAM in FIFO mode

In FIFO configuration, the incoming address signals are ignored. Instead, internal read and write pointers with correct alignment according to bitwidth are forwarded to the SRAM macros. Furthermore, there exist additional output signals which are solely used for FIFO monitoring and are described in Table 2.10. The F_ALMOST_FULL_FLAG and F_ALMOST_EMPTY_FLAG give an early warning when the FIFO is approaching its limits. Its offset can be configured using a 13 bit register during configuration or it is set dynamically using the inputs F_ALMOST_FULL_OFFSET and F_ALMOST_EMPTY_OFFSET.

Moreover, the FIFO controller has a dedicated active low reset input signal F_RST_N which is synchronized into clock domain internally.

Table 2.10: FIFO status flags

Flag	Width	Description
F_FULL	1	All entries in the FIFO are filled, is set on the rising edge of the write clock (asynchronous)
F_EMPTY	1	The FIFO is empty, is set on the rising edge of the read clock (asynchronous)
F_ALMOST_FULL	1	Almost all entries in the FIFO are filled, is set on the rising edge of the write clock (asynchronous)
F_ALMOST_EMPTY	1	Almost all entries in FIFO have been read, is set on the rising edge of the read clock (asynchronous)
F_READ_ADDRESS	16	Current FIFO read pointer
F_WRITE_ADDRESS	16	Current FIFO write pointer
F_RD_ERR	1	Is set if FIFO is empty and a read access takes place
F_WR_ERR	1	Is set if FIFO is full and data is pushed, new data will be lost

Table 2.11 illustrates the valid FIFO data concatenations for the variable bitwidth data TDP mode. B_EN and B_WE are the write / push enable and A_EN is the read / pop enable signal.

Table 2.11: FIFO 40 bit data concatenations

Function	Width	Concatenation
Push data	40	B_DI[39:0]
Push bitmask	40	B_BM[39:0]
Pop data	40	A_DO[39:0]

Table 2.12 illustrates the valid FIFO data concatenations for the 80 bit data SDP mode. B_EN and B_WE are the write / push enable and A_EN is the read / pop enable signal.

Table 2.12: FIFO 80 bit data concatenations

Function	Width	Concatenation
Push data	80	B_DI[39:0] ◦ A_DI[39:0]
Push bitmask	80	B_BM[39:0] ◦ A_BM[39:0]
Pop data	80	B_DO[39:0] ◦ A_DO[39:0]

¹ Symbol ◦ is concatenation.

Synchronous FIFO Access

Write / push and read / pop pointers are both registered with the rising clock edge of A_CLK. During the write / push operation, the data word available at {A, B}_DI / {A, B}_BM is written into the FIFO whenever the B_EN and B_WE signals are active one setup time before the rising clock edge of A_CLK. The write / push operation presents the data word at {A0, A1}_DO whenever the A_EN signal is active one setup time the rising clock edge of A_CLK.

The signals empty, full, almost empty, almost full, read and write error are combinatorial computed out of read and write pointer. The error flags are not sticky.

The timing diagram in Figure 2.18 illustrates the writing to an empty synchronous FIFO.

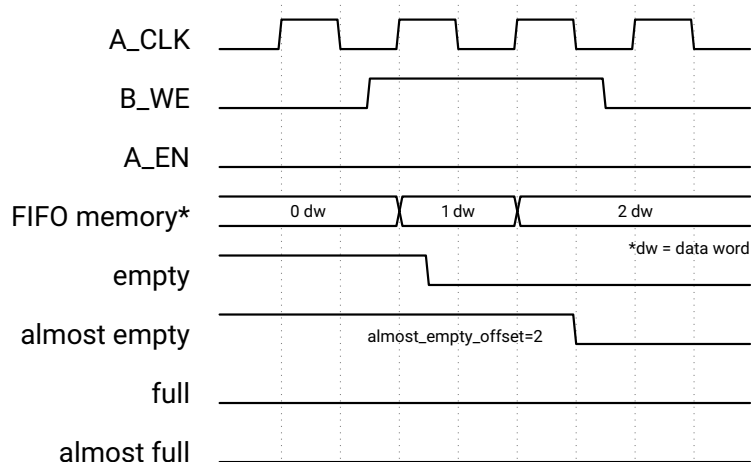

Figure 2.18: Writing to an empty synchronous FIFO

The timing diagram in Figure 2.19 illustrates the writing to an almost full synchronous FIFO.

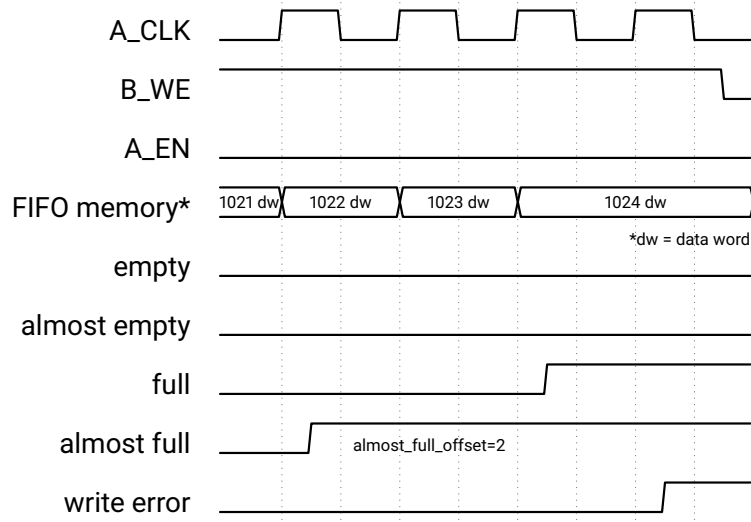

Figure 2.19: Writing to an almost full synchronous FIFO

The timing diagram in Figure 2.20 illustrates the reading from a full synchronous FIFO.

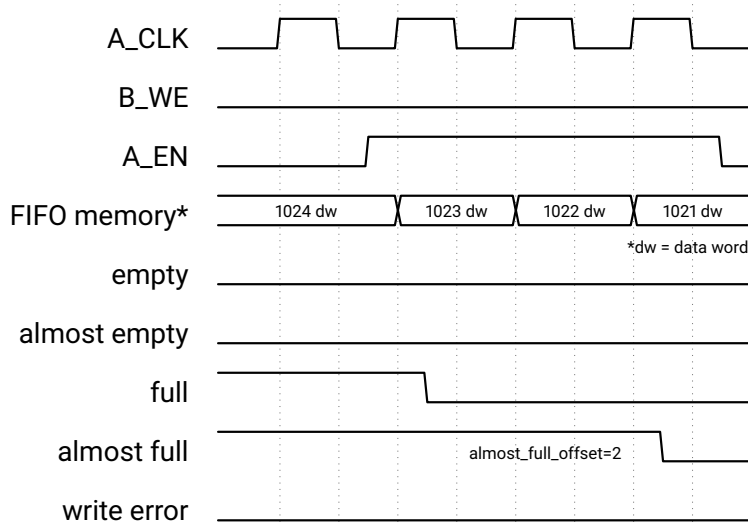

Figure 2.20: Reading from a full synchronous FIFO

The timing diagram in Figure 2.21 illustrates the reading from an almost empty synchronous FIFO.

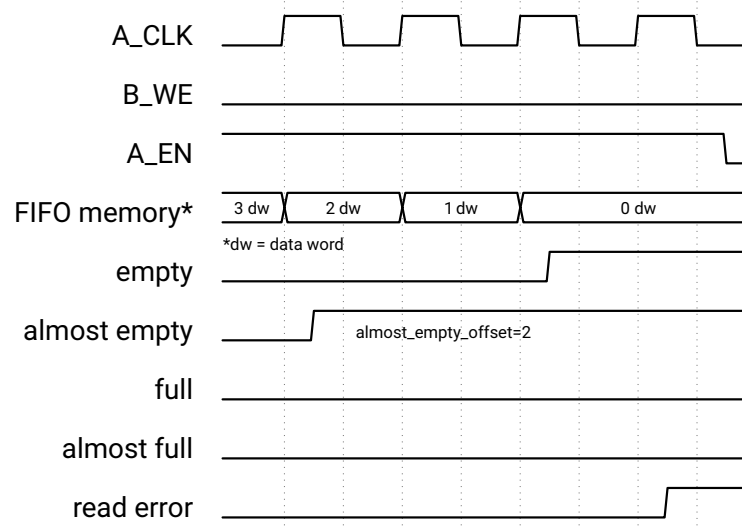

Figure 2.21: Reading from an almost empty synchronous FIFO

Asynchronous FIFO Access

During the write / push operation, the data word available at $\{A, B\}_{DI}$ / $\{A, B\}_{BM}$ is written into the FIFO whenever the B_{EN} and B_{WE} signals are active one setup time before the rising clock edge of B_{CLK} . The write / push operation presents the data word at $\{A, B\}_{DO}$ whenever the A_{EN} signal is active one setup time the rising clock edge of A_{CLK} . The read / pop pointer is registered with the read / pop clock A_{CLK} , the write / push pointer is registered with the write / push clock B_{CLK} .

For full, empty, almost full, almost empty, read and write error signal generation the read pointer is synchronized into the write clock domain via Gray encoding and 2-stage synchronization, the write pointer is synchronized into the read clock domain via Gray encoding and 2-stage synchronization.

The empty, almost empty and read error signals are combinatorial computed out of the read / pop pointer and the synchronized write / push pointer. By that, the empty, almost empty and read error signals will be always cycle accurate with the read clock without any delay and a read from an empty FIFO can always be prevented.

In Figures 2.22 to 2.25, these signals are highlighted in red relate to the read side of the FIFO since their computation bases on flip-flops driven by the read / pop clock. The full, almost full and write error signals are combinatorial computed out of the write / push pointer and the synchronized read / pop pointer. By that, the full, almost full and write error signals will be always cycle accurate with the write clock without any delay and a write to a full FIFO can always be prevented.

Moreover, the signals highlighted in green are related to the write side of the FIFO since their computation bases on flip-flops driven by the write / push clock.

The timing diagram in Figure 2.22 illustrates the writing to an empty asynchronous FIFO.

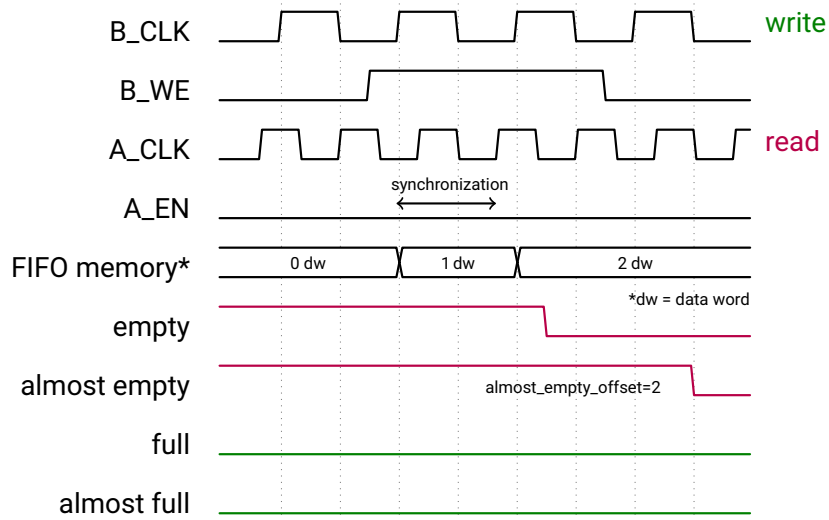

Figure 2.22: Writing to an empty asynchronous FIFO

The timing diagram in Figure 2.23 illustrates the writing to an almost full asynchronous FIFO.

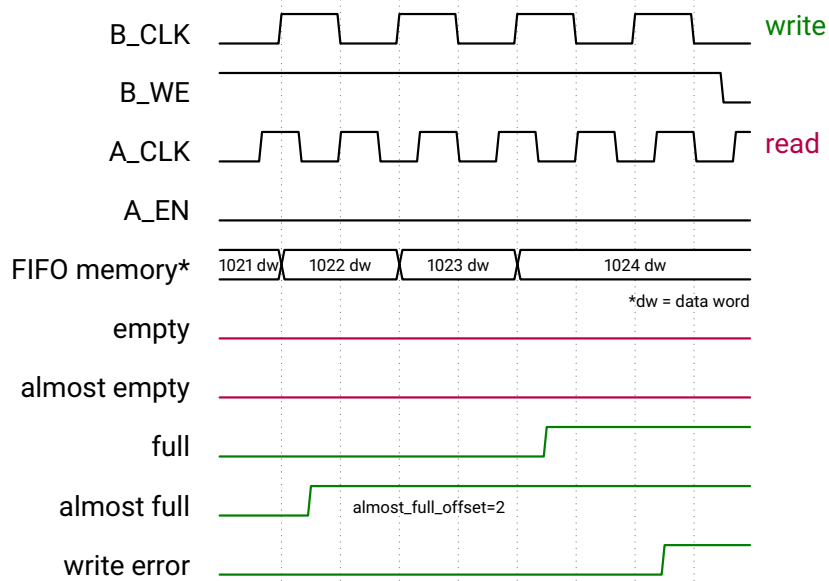

Figure 2.23: Writing to an almost full asynchronous FIFO

The timing diagram in Figure 2.24 illustrates the reading from a full asynchronous FIFO.

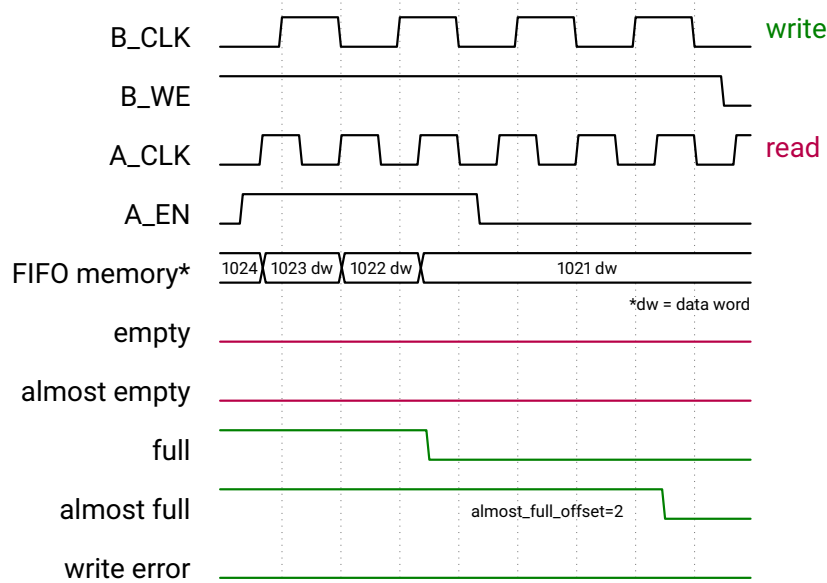

Figure 2.24: Reading from a full asynchronous FIFO

The timing diagram in Figure 2.25 illustrates the reading from a full asynchronous FIFO.

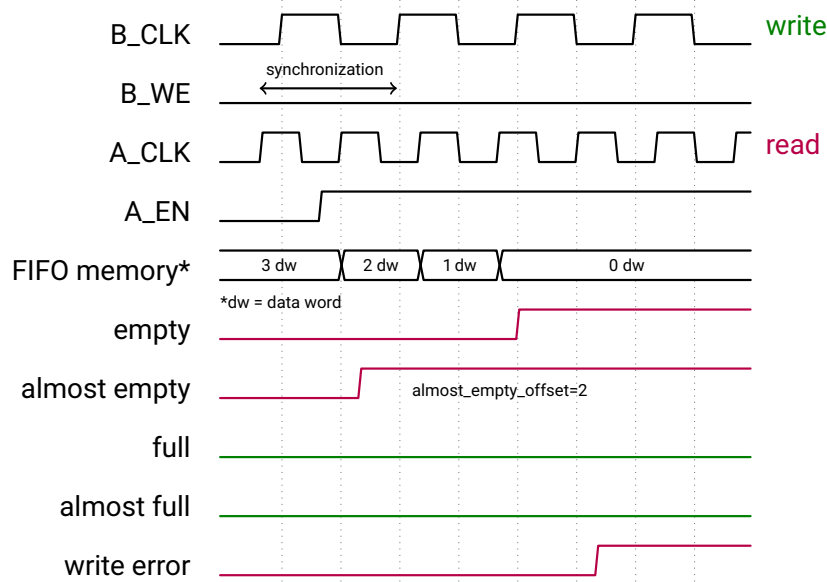

Figure 2.25: Reading from an almost empty asynchronous FIFO

2.5 Clock Generators (PLLs)

Four independent PLL clock generators are available:

- All-digital phase-locked loop (ADPLL) clock generator for versatile FPGA clock generation.
- Clock generation based on a digitally controlled oscillator (DCO) running with a typical frequency tuning range from 1 GHz to 2 GHz.
- Programmable clock frequency dividers for reference clock input, PLL loop divider and core clock outputs, enabling wide output and reference frequency ranges.
- Core clock outputs available at four 90°-spaced phases.
- Fast lock-in by binary frequency search.
- Autonomous free-running oscillator mode for FPGA configuration clock after power-up.

The maximum oscillator frequency depends on the FPGA supply voltage as follows:

Low power mode: ($V_{DD_{PLL}} = 0.9\text{ V} \pm 50\text{ mV}$): 1.000 MHz

Economy mode: ($V_{DD_{PLL}} = 1.0\text{ V} \pm 50\text{ mV}$): 2.000 MHz

Speed mode: ($V_{DD_{PLL}} = 1.1\text{ V} \pm 50\text{ mV}$): 2.500 MHz

The maximum PLL output frequency also depends on the FPGA supply voltage as follows:

Low power mode: ($V_{DD_{PLL}} = 0.9\text{ V} \pm 50\text{ mV}$): 250 MHz

Economy mode: ($V_{DD_{PLL}} = 1.0\text{ V} \pm 50\text{ mV}$): 312.5 MHz

Speed mode: ($V_{DD_{PLL}} = 1.1\text{ V} \pm 50\text{ mV}$): 416.75 MHz

There are different reference clock pins selectable individually for each PLL:

- SerDes clock input SER_CLK (pin T12, can also be used as general purpose clock input)
- Clock input CLK0 (2nd function of pin N14, 1st function is GPIO IO_SB_A8)
- Clock input CLK1 (2nd function of pin P12, 1st function is GPIO IO_SB_A7)
- Clock input CLK2 (2nd function of pin P14, 1st function is GPIO IO_SB_A6)
- Clock input CLK3 (2nd function of pin R13, 1st function is GPIO IO_SB_A5)

Reference clocks can be used simultaneously by several PLLs.

2.6 Global Mesh Architecture

2.6.1 Overview of the Global Mesh Signal Injection

The Global Mesh consists of four signal traces which are used to distribute signals over the entire chip area. This is mainly used for clock signals, but is also useful for high fanout signals, e.g. enable or user reset.

Figure 2.26 shows that the signal feed into the Global Mesh is closely linked to the clock generation. The modules involved are described in detail in the following sections.

2.6.2 Clock Input Multiplexers CLKIN

The GateMate FPGA has four dedicated clock input pins CLK0..CLK3. These clock pins are the second pin functions of GPIO pins (see list on page 45). Further, SER_CLK can be used to feed-in a clock signal to the FPGA.

From these five input clocks the CLKIN module selects four output clocks as shown in Figure 2.27. Clock inversion (180° phasing) is configurable to any CLKIN clock output PCLK[3:0]. These clocks are forwarded to the PLLs.

2.6.3 PLL Wrapper

There are four PLL wrappers, each with a PLL as described in Section 2.5. Every clock output from the CLKIN multiplexers can be used as reference clock of a PLL. Figure 2.28 shows that these PCLK[3:0] clocks and alternative user clocks USR_PCLK[3:0] from CPE outputs RAM_01 can be selected as PLL reference inputs.

Each PLL selects one of the input clocks and generates an output frequency that is output with four phases 0°, 90°, 180° and 270°. The logic block shown in Figure 2.28 contains setting options for clock output enable, locked state required and frequency doubling for 180° and 270° output clocks. In addition, both input clocks can be bypassed inside the PLL wrapper.

Table 2.13: *USR_PCLK<n> sources*

PLL	CPE coordinate	CPE output
0	CPE(1,124)	RAM_01
1	CPE(1,123)	RAM_01
2	CPE(1,122)	RAM_01
3	CPE(1,121)	RAM_01

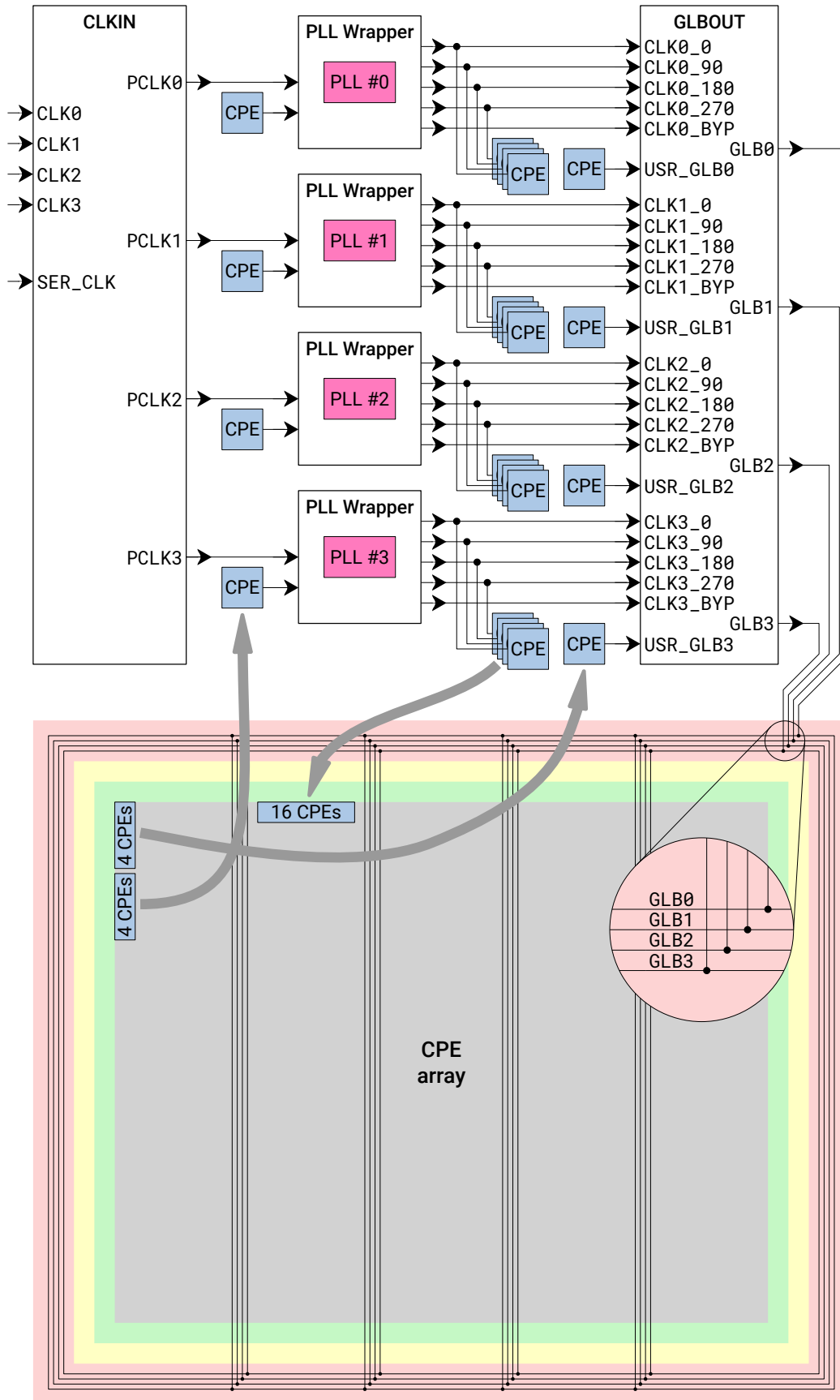

Figure 2.26: Overview of the Global Mesh signal injection

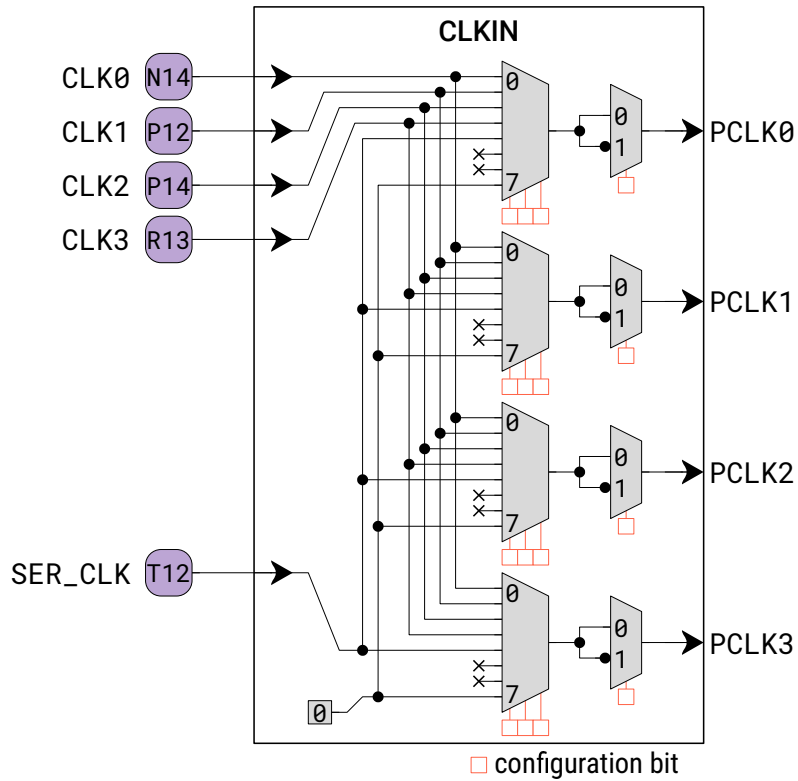

Figure 2.27: Clock input multiplexers CLKIN

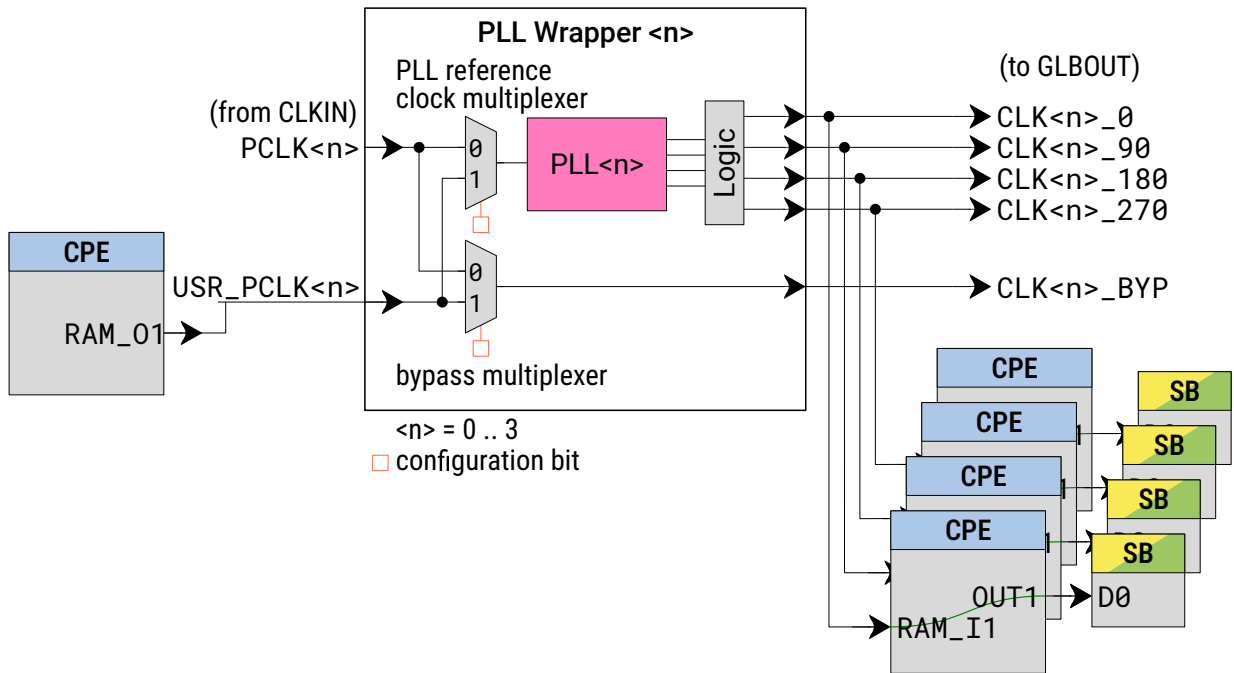

Figure 2.28: PLL wrapper with input and output clocks

The four PLL wrapper output clocks are connected to the GLBOUT module (see page 49) as well as to CPE inputs RAM_I1. From there, via CPE . OUT1, the clock signals are routed to Switch Boxes. Details to the CPE coordinates are given in Table 2.14.

Table 2.14: CPE destinations of PLL clock output signals

PLL	PLL clock output	CPE coordinate	CPE input / output
0	CLK0_0	CPE(39,128)	RAM_I1 / OUT1
0	CLK0_90	CPE(40,128)	RAM_I1 / OUT1
0	CLK0_180	CPE(41,128)	RAM_I1 / OUT1
0	CLK0_270	CPE(42,128)	RAM_I1 / OUT1
1	CLK1_0	CPE(43,128)	RAM_I1 / OUT1
1	CLK1_90	CPE(44,128)	RAM_I1 / OUT1
1	CLK1_180	CPE(45,128)	RAM_I1 / OUT1
1	CLK1_270	CPE(46,128)	RAM_I1 / OUT1
2	CLK2_0	CPE(47,128)	RAM_I1 / OUT1
2	CLK2_90	CPE(48,128)	RAM_I1 / OUT1
2	CLK2_180	CPE(49,128)	RAM_I1 / OUT1
2	CLK2_270	CPE(50,128)	RAM_I1 / OUT1
3	CLK3_0	CPE(51,128)	RAM_I1 / OUT1
3	CLK3_90	CPE(52,128)	RAM_I1 / OUT1
3	CLK3_180	CPE(53,128)	RAM_I1 / OUT1
3	CLK3_270	CPE(54,128)	RAM_I1 / OUT1

2.6.4 GLBOUT Multiplexers

The GLBOUT multiplexers are connected to five signals from a PLL wrapper (PLL output clock with four phases and bypassed clock) and four additional user signals USR_GLB [3 : 0] from dedicated CPE outputs RAM_01 as shown in Table 2.15. Figure 2.29 shows, how these input signals can be selected to generate the four output signals GLB [3 : 0].

In most cases, GLB [3 : 0] are clock signals. But the user signals can also be other signals, typically high fanout signals, e.g. enable or user reset.

The GLB [3 : 0] are fed into the Global Mesh and can be accessed at many points with very low skew.

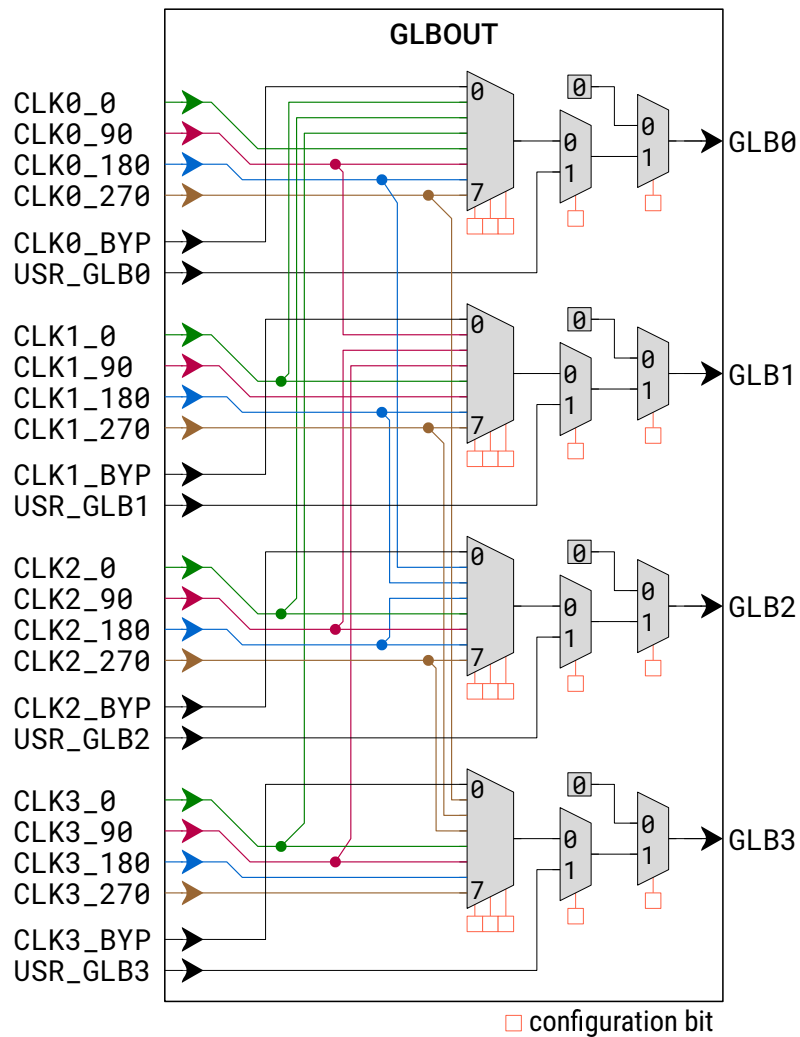

Figure 2.29: GLBOUT multiplexers

Table 2.15: USR_GLB[3:0] sources

Signal	CPE coordinate	CPE output
USR_GLB0	CPE(1,128)	RAM_01
USR_GLB1	CPE(1,127)	RAM_01
USR_GLB2	CPE(1,126)	RAM_01
USR_GLB3	CPE(1,125)	RAM_01

2.6.5 Use of the CC_BUFGE Elements in HDL Design Sources

CC_BUFGE elements are used to feed signals into the Global Mesh. As there are four nets in this mesh, a maximum of four CC_BUFGE elements can be used in a design. If there are more, Place & Route will terminate with an error message. If there is no CC_BUFGE element, the Global Mesh will not be used.

The synthesis distinguishes between clock signals and other signals to decide whether a CC_BUFGE element is inserted or not. Therefore, some primitives have clock input ports, namely:

CC_IDDR.CLK	CC_BRAM_20K.A_CLK
CC_ODDR.CLK	CC_BRAM_20K.B_CLK
CC_DFF.CLK	CC_BRAM_40K.A_CLK
CC_DLT.G	CC_BRAM_40K.B_CLK
	CC_FIFO_40K.A_CLK
	CC_FIFO_40K.B_CLK

There are four steps from the user design to the FPGA bitstream:

1. Manual CC_BUFGE instantiation:

- The user can insert a CC_BUFGE element to any signal. These signals will be routed over the Global Mesh. Up to four CC_BUFGE elements can be inserted.

2. Synthesis option:

- If the synthesis program gets started with the '-noclkbuf' option, no CC_BUFGE elements will be inserted by the synthesis program.
- If the option '-noclkbuf' is not used, the synthesis will insert automatically CC_BUFGE elements to all nets which have dedicated clock inputs. Clock input nets are specified for primitive ports as listed above.

3. User intervention:

- Before executing Place & Route, the user has to check how many CC_BUFGE elements are included in the design.
- If there are more than four CC_BUFGE elements, the user has to repeat the first step and then, of course, the synthesis has to be started again with the '-noclkbuf' option. Otherwise, the Place & Route execution will fail with an error message.

4. Place & Route execution:

- The assignment of GLB[3:0] signals to the CC_BUFGE elements is done by the Place & Route software during the routing process. There is no need for the user to do this manually.

2.7 Clocking Schemes

2.7.1 The Methods of Clock Distribution

The Global Mesh can be used to distribute up to four signals over the entire chip area with small clock skew. The Global Mesh is typically used for clock signals. However, other signals, mostly high fan-out control signals like enable or user reset, can also be distributed with the Global Mesh instead. The edge frame of the chip contains a ring that distributes the Global Mesh signals (see also Figure 2.26 in previous Section 2.6.1). Four additional vertical trace structures bring the signals closer to the inside of the FPGA fabric.

This section describes several methods to distribute clock signals in the FPGA fabric. Essentially, the signals can be distributed to the user circuit in three ways:

1. Routing without using the Global Mesh. All signals are routed via the routing structure without any dedicated clock resources, as shown in Section 2.7.2.
2. Using the Global Mesh to distribute the Global Mesh signals as shown in Section 2.7.3.
3. Using CP-lines to distribute and forward clock and an associated enable signal over the entire chip area for clock-skew reduction, as shown in Section 2.7.4.

Figure 2.30 illustrates that there are four ways to pick up the Global Mesh signals:

Pick-up option 1: On the left edge every y position has a Left Edge Select (LES) element which can feed two signals

$$\begin{aligned} \text{LES}(-2, y).\text{CPE_CINX} &\rightarrow \text{CPE}(1, y).\text{CINX} \\ \text{LES}(-2, y).\text{CPE_PINX} &\rightarrow \text{CPE}(1, y).\text{PINX} \end{aligned}$$

with $1 \leq y \leq 128$ from the Global Mesh to CPE inputs.

Pick-up option 2: On the bottom edge every x position has a Bottom Edge Select (BES) element which can feed two signals

$$\begin{aligned} \text{BES}(x, -2).\text{CPE_CINY2} &\rightarrow \text{CPE}(x, 1).\text{CINY2} \\ \text{BES}(x, -2).\text{CPE_PINY2} &\rightarrow \text{CPE}(x, 1).\text{PINY2} \end{aligned}$$

with $1 \leq x \leq 160$ from the Global Mesh to CPE inputs.

Pick-up option 3: On all four edges every coordinate can feed all signals $\text{GLB}[3:0]$ to a Big Switch Box (SB_BIG) stack as shown in Table 2.16. The specification $\text{SB_BIG}(x, y, p)$ gives the x and y coordinates as well as the plane $1 \leq p \leq 12$. At the same coordinate (x, y) every Global Mesh signal is fed in parallel in three planes.

Pick-up option 4: Furthermore, the Global Mesh signals can be fed into the CPE array in four columns. Table 2.17 details which CPE coordinates and input signals are involved. Please notice that from the CPE input ports the signals are directly routed to Switch Box inputs:

$$\begin{aligned} \text{CPE.RAM_I1} &\rightarrow \text{CPE.OUT1} \rightarrow \text{SB.D0} \\ \text{CPE.RAM_I2} &\rightarrow \text{CPE.OUT2} \rightarrow \text{SB.D0} \end{aligned}$$

According to Table 2.18, the selection of the clocking scheme is made by the settings regarding CC_BUFG usage and the synthesis option ‘-noclkbuf’.

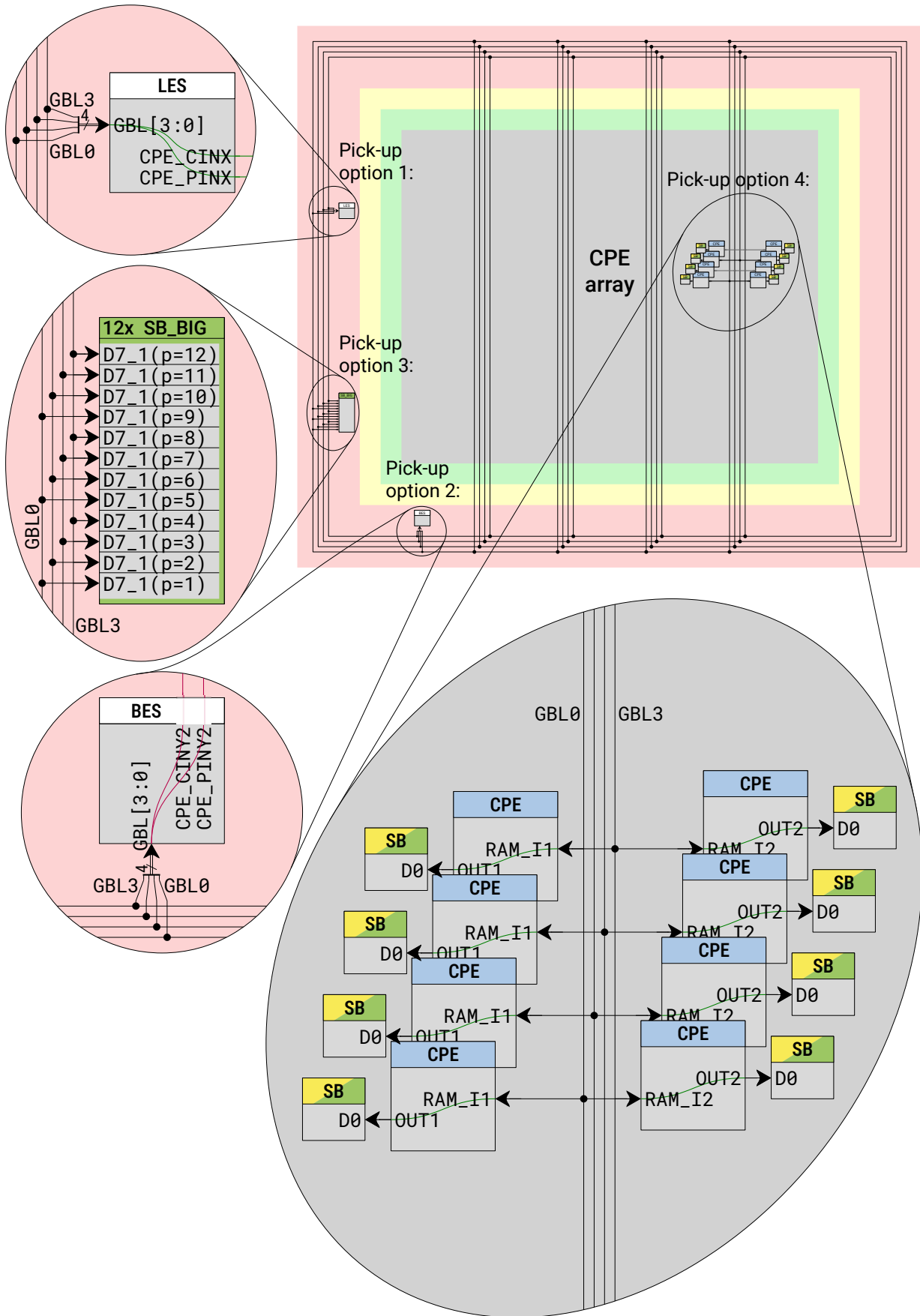

Figure 2.30: Overview of signal extraction from the Global Mesh

Table 2.16: Connecting Global Mesh signals to Switch Boxes (pick-up option 3)

FPGA edge	Signal	Target	Conditions
Left edge	GLB0	\rightarrow SB_BIG($x, y, \{1, 5, 9\}$).D7_1	$x = \begin{cases} 2 - (y \bmod 4) ; 0 \leq y \leq 130 \\ -1 ; y = -1 \end{cases}$
	GLB1	\rightarrow SB_BIG($x, y, \{2, 6, 10\}$).D7_1	
	GLB2	\rightarrow SB_BIG($x, y, \{3, 7, 11\}$).D7_1	
	GLB3	\rightarrow SB_BIG($x, y, \{4, 8, 12\}$).D7_1	
Bottom edge	GLB0	\rightarrow SB_BIG($x, y, \{1, 5, 9\}$).D7_2	$y = \begin{cases} 2 - (x \bmod 4) ; 0 \leq x \leq 162 \\ -1 ; x = -1 \end{cases}$
	GLB1	\rightarrow SB_BIG($x, y, \{2, 6, 10\}$).D7_2	
	GLB2	\rightarrow SB_BIG($x, y, \{3, 7, 11\}$).D7_2	
	GLB3	\rightarrow SB_BIG($x, y, \{4, 8, 12\}$).D7_2	
Right edge	GLB0	\rightarrow SB_BIG($x, y, \{1, 5, 9\}$).D7_3	$x = \begin{cases} 2 - (y \bmod 4) + 160 ; 0 \leq y \leq 130 \\ 159 ; y = -1 \end{cases}$
	GLB1	\rightarrow SB_BIG($x, y, \{2, 6, 10\}$).D7_3	
	GLB2	\rightarrow SB_BIG($x, y, \{3, 7, 11\}$).D7_3	
	GLB3	\rightarrow SB_BIG($x, y, \{4, 8, 12\}$).D7_3	
Top edge	GLB0	\rightarrow SB_BIG($x, y, \{1, 5, 9\}$).D7_4	$y = \begin{cases} 2 - (x \bmod 4) + 128 ; 0 \leq x \leq 162 \\ 127 ; x = -1 \end{cases}$
	GLB1	\rightarrow SB_BIG($x, y, \{2, 6, 10\}$).D7_4	
	GLB2	\rightarrow SB_BIG($x, y, \{3, 7, 11\}$).D7_4	
	GLB3	\rightarrow SB_BIG($x, y, \{4, 8, 12\}$).D7_4	

Table 2.17: Connecting Global Mesh signals to CPEs (pick-up option 4)

Signal	Target	
GLB0	\rightarrow CPE($x_0 - 3, y_0 + 10$).RAM_I1	$x_0 = 33 + m \cdot 32 ; 0 \leq m \leq 3$ $= \{33, 65, 97, 129\}$
GLB1	\rightarrow CPE($x_0 - 3, y_0 + 11$).RAM_I1	
GLB2	\rightarrow CPE($x_0 - 3, y_0 + 12$).RAM_I1	
GLB3	\rightarrow CPE($x_0 - 3, y_0 + 13$).RAM_I1	
GLB0	\rightarrow CPE($x_0 + 2, y_0 + 10$).RAM_I2	$y_0 = 1 + n \cdot 16 ; 0 \leq n \leq 7$ $= \{1, 17, 33, 49, 65, 81, 97, 113\}$
GLB1	\rightarrow CPE($x_0 + 2, y_0 + 11$).RAM_I2	
GLB2	\rightarrow CPE($x_0 + 2, y_0 + 12$).RAM_I2	
GLB3	\rightarrow CPE($x_0 + 2, y_0 + 13$).RAM_I2	

Table 2.18: *Control of the clocking scheme via CC_BUFG and CP-lines*

Number of clock signals with CC_BUFG	CP-lines	Section	Clocking scheme
0	disabled	2.7.2	Clock distribution via the routing structure
0	enabled	2.7.4.1	Intake CPE with chained CPE row
		2.7.4.2	Intake BES with chained BES row
		2.7.4.4	Intake LES with chained CPE row
1..4	disabled	2.7.3	Clock distribution via the Global Mesh
1..4	enabled	2.7.4.1	Intake CPE with chained CPE row
		2.7.4.3	Unchained BES row with Global Mesh pick-up
		2.7.4.2	Intake BES with chained BES row
		2.7.4.4	Intake LES with chained CPE row

2.7.2 Clock Distribution via the Routing Structure

The most general clocking scheme is the routing of clock signals through the routing structure. In this scheme, no clock signals may be in the Global Mesh and Place & Route must be started with the ‘--clk_CP’ option. Any number of clock domains can be realized in any design.

However, the traces in the Global Mesh can distribute any other signals. They can be accessed with the pick-up options 3 (SB_BIG) and 4 (CPE) which are shown in Figure 2.30. The edge elements LES and BES are not available.

- 👍 With regard to electromagnetic interference (EMI), this clocking scheme is to be preferred. However, since no dedicated clocking resource is involved, the routing of clock signals via CPE and routing architecture might lead to high clock skew. This problem is addressed and cared about by the Place & Route software.
- 👎 On the other hand, this clocking scheme reduces the maximum clock frequency. If this is a problem, the following sections show possible solutions.

2.7.3 Clock Distribution via the Global Mesh

When using this scheme, the shortest path from any point in the Global Mesh to the user circuit is used to route the clock signal into the CPE array. Pick-up option 3 (SB_BIG) shown in Figure 2.30 is used.

Prerequisite for this clocking scheme is that clocks are in the Global Mesh and Place & Route is started with the ‘--clk_CP’ option.

If not all traces in the Global Mesh are assigned with clock signals, free traces can distribute arbitrary other signals. Pick-up options 3 (SB_BIG) and 4 (CPE) are used to access these signals.

A maximum of four signals are allowed in the Global Mesh. If there are more, Place & Route will terminate with an error message.

- 👎 Since the Global Mesh signals are distributed simultaneously over the entire chip area, this clocking scheme leads to poorer EMI characteristics.
- 👍 On the other hand, Global Mesh signals have fast interconnection to arbitrary locations in the FPGA die, reducing the clock skew.

2.7.4 Clock Distribution via CP-lines

CP-lines can be used for fast clock routing in the entire chip area. This can be combined with clock distribution over the Global Mesh or the clock signals can be provided via the routing structure.

There are several ways to feed clock signals to the user circuit via CP-lines. In the following sections it is assumed that the user circuit occupies a rectangular area in the CPE array. This area is highlighted in the following Figures 2.31 to 2.34.

A clock signal and its associated enable signal are picked up by a so-called *intake element* and distributed via CP-lines. It is irrelevant whether one or both signals are in the Global Mesh or reach the intake element via the routing structure.

In the FPGA only one clock / enable signal pair can be routed via CP-lines. The enable signal is optional.

Prerequisite for this clocking scheme is that Place & Route is started with the ‘++clk_CP’ option.

The principle of clock distribution via CP-lines can be differentiated into four types:

1. Intake CPE with chained CPE row (Section 2.7.4.1 on page 58)
2. Intake BES with chained BES row (Section 2.7.4.2 on page 59)
3. Unchained BES row with Global Mesh pick-up (Section 2.7.4.3 on page 60)
4. Intake LES with chained CPE row (Section 2.7.4.4 on page 61)

2.7.4.1 Intake CPE with chained CPE row

This clocking scheme inserts a horizontal CPE chain from $(x_0 - 1, y_0 - 1)$ to $(x_1, y_0 - 1)$ below the user circuit in its rectangular area with the lower left corner (x_0, y_0) and the upper right corner (x_1, y_1) (striped area in Figure 2.31) and forwards the clock signals via CP-lines in y direction. This allows a minimal clock skew in x and y direction. The intake CPE $(x_0 - 1, y_0 - 1)$ can be fed from the Global Mesh or from any signal in the routing structure.

Prerequisite for this clocking scheme is that at least one horizontal CPE row under the user circuit is not occupied.

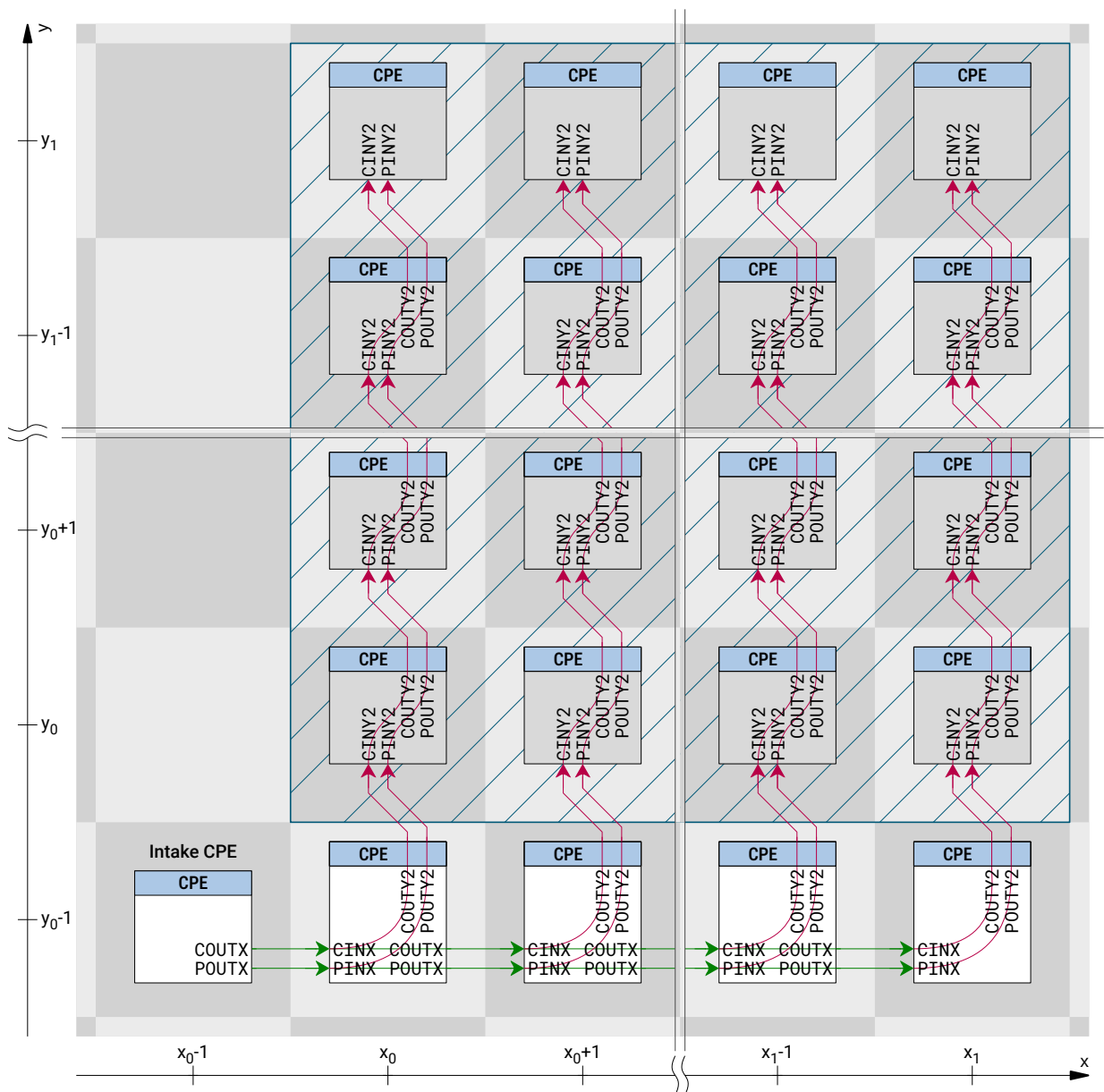

Figure 2.31: Intake CPE with chained CPE row

2.7.4.2 Intake BES with chained BES row

If there is no space below the user circuit (see striped area with the lower left corner $(x_0, 1)$ and the upper right corner (x_1, y_1) in Figure 2.32) to insert the additional CPE chain, clock and optional enable signal can be fed into the intake Bottom Edge Select (BES) element $(x_0, -2)$. From there, the signals are continued to coordinate $(x_1, -2)$.

The intake BES $(x_0, -2)$ can route Global Mesh signals as well as any signal from the routing structure to the CPE array.

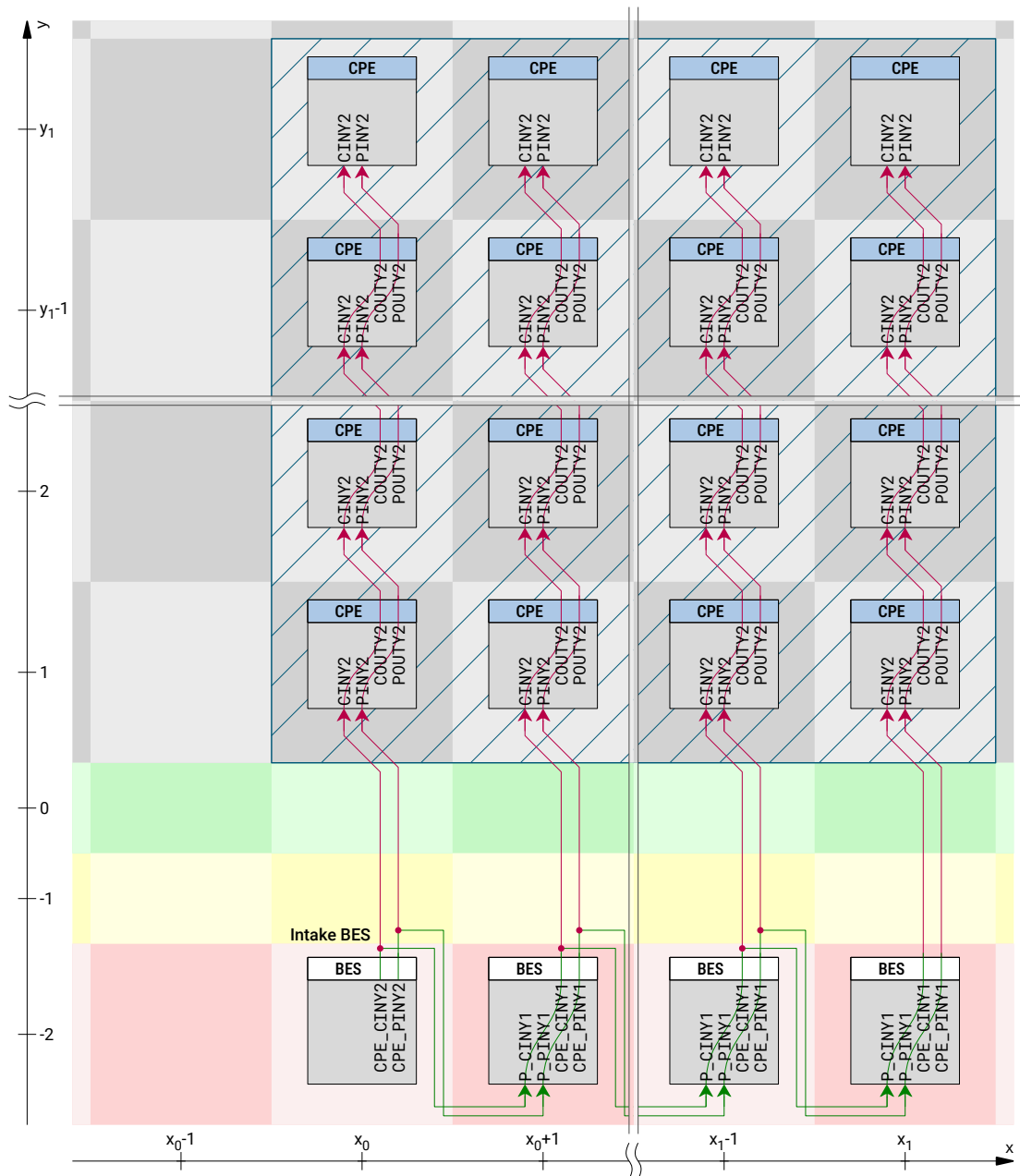

Figure 2.32: Intake BES with chained BES row

2.7.4.3 Unchained BES row with Global Mesh pick-up

As a variant of the previous Section 2.7.4.2, each one of the BES elements from $(x_0, -2)$ to $(x_1, -2)$ can pick up two Global Mesh signals as shown in Figure 2.33. In this case, clock skew occurs only in y direction.

Deviating from Figure 2.33, it is also possible to pick up only one of the two signals directly from the Global Mesh and chain the other signal via the BES elements as shown in Figure 2.32.

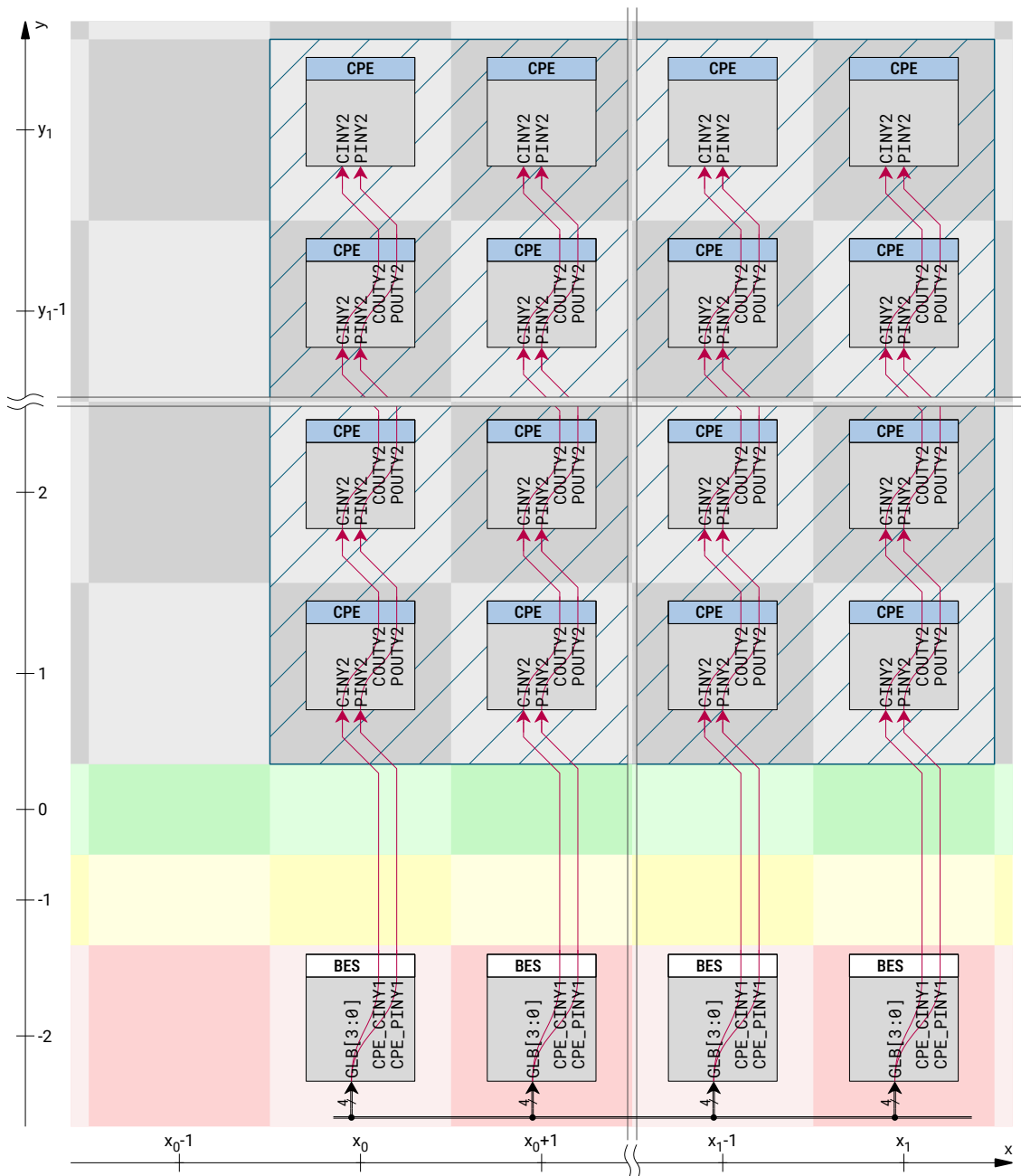

Figure 2.33: Unchained BES row with Global Mesh pick-up

2.7.4.4 Intake LES with chained CPE row

If the user circuit in its rectangular area with the lower left corner $(1, y_0)$ and the upper right corner (x_1, y_1) abuts the left edge of the CPE array (striped area in Figure 2.34), i.e. due to its size or placement in the CPE array, the intake Left Edge Select (LES) element $(-2, y_0 - 1)$ forwards the signal in x direction through the additional horizontal CPE chain from $(1, y_0 - 1)$ to $(x_1, y_0 - 1)$ below the user circuit. The intake LES can be fed from the Global Mesh or from any signal in the routing structure.

Prerequisite for this clocking scheme is that at least one horizontal CPE row under the user circuit is not occupied.

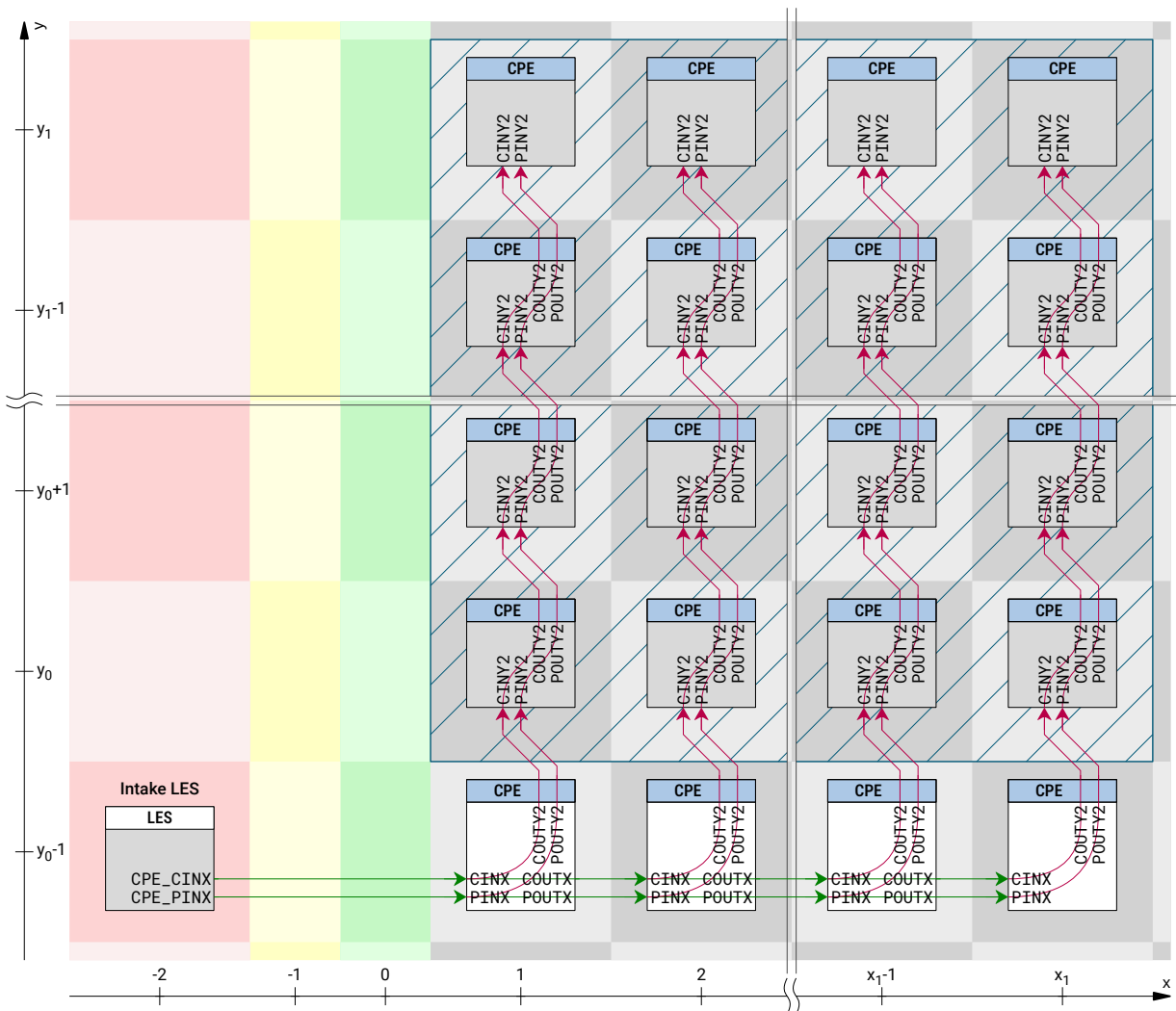

Figure 2.34: Intake LES with chained CPE row

2.8 Routing Structure

All functional elements of the GateMate™ FPGA are interconnected by the routing structure. This consists of so-called *Switch Boxes (SBs)* mainly and is supplemented by additional *Input Multiplexers (IMs)* and *Output Multiplexers (OMs)*. All Switch Boxes are arranged in a matrix $(x, y) = (-1, -1) \dots (162, 130)$ as shown in Figure 2.35.

Every second coordinate is populated by Switch Boxes. There are two types of Switch Boxes which differ only in the span they can forward into the routing matrix. Mainly, Switch Boxes connect bidirectional to other Switch Boxes in horizontal and vertical direction. Big Switch Boxes connect six other Switch Boxes in every direction and Small Switch Boxes only two others. Direction change from vertical to horizontal and vice versa

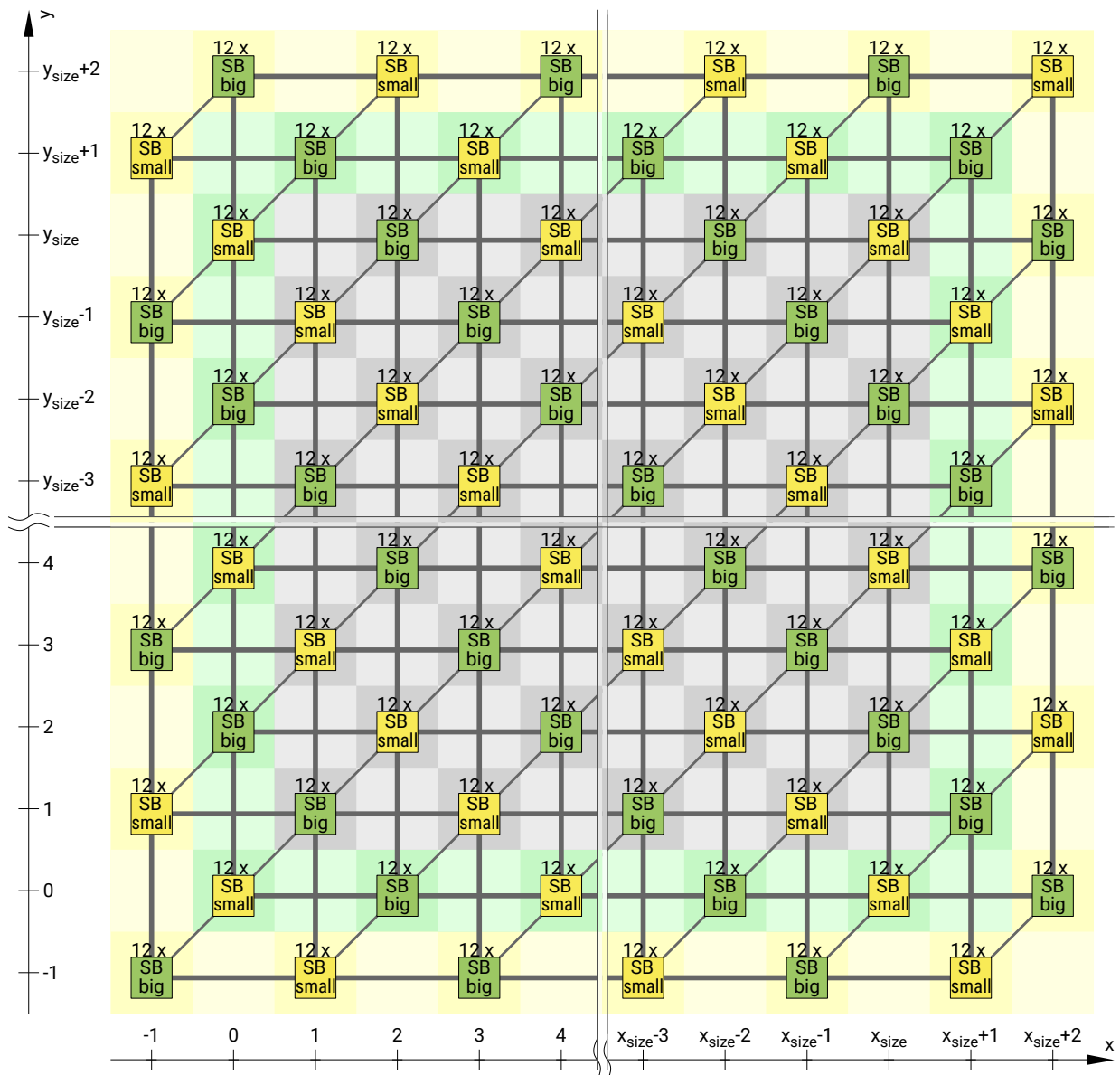

Figure 2.35: Switch Box (SB) interconnection scheme

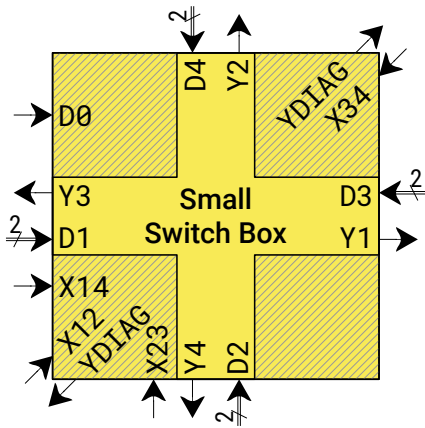

Figure 2.36: Small Switch Box

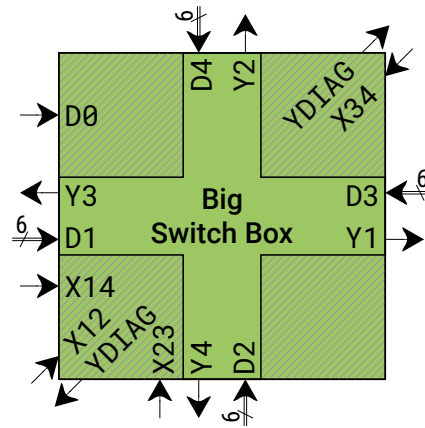

Figure 2.37: Big Switch Box

is possible. From an arbitrary point (x_n, y_m) all coordinates in row y_m or column x_n are reachable.

Furthermore, diagonal neighbors to upper right (x_n+1, y_m+1) and lower left (x_n-1, y_m-1) coordinate can be connected. This allows change to neighbored rows or columns.

Signals are feed into the routing structure either directly from CPE outputs or, for more flexibility, through Output Multiplexers (OMs). GPIO input signals are connected to the Switch Boxes as well.

The Switch Boxes decouple all signals through Input Multiplexers (IMs) to the CPEs.

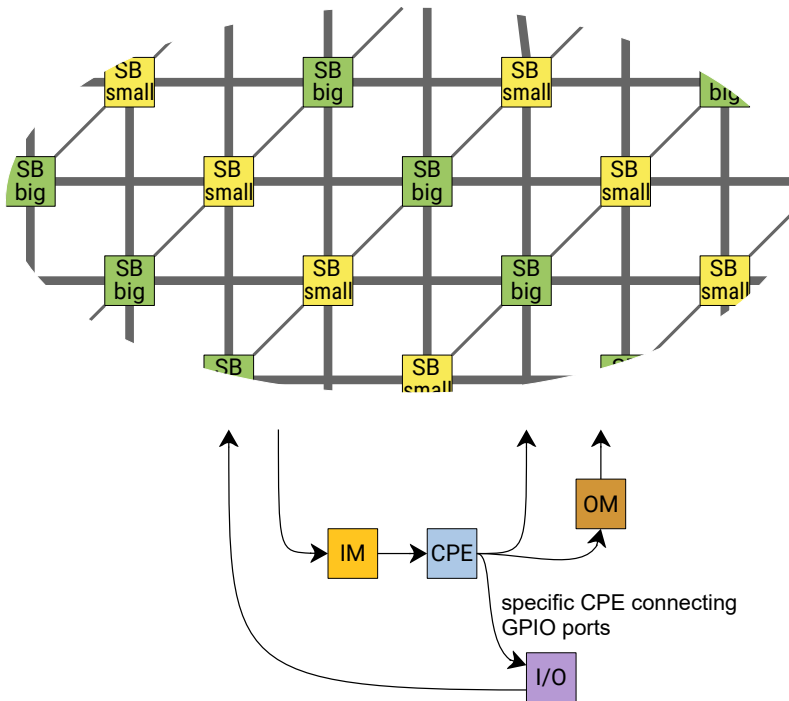

Figure 2.38: CPE connections to the routing structure

2.9 Power Supply

The GateMate™ FPGA has a single power supply for the chip core and GPIO power supply pins for each GPIO bank. There are some more power pins for dedicated parts of the FPGA:

VDD: Core supply voltage.

VDD_CLK: Supply voltage for the input pins SER_CLK, SER_CLK_N, RST_N and POR_ADJ.

VDD_PLL: Supply pin for PLLs.

VDD_SER: Supply pin for the SerDes module.

VDD_SER_PLL: Supply pin for the SerDes PLL.

VDD_EA, VDD_EB, VDD_NA, VDD_NB, VDD_SA, VDD_SB, VDD_WA, VDD_WB and VDD_WC:
Supply pins for GPIO banks.

Core voltage can be chosen to select the application mode:

Low power mode: $VDD = 0.9\text{ V} \pm 50\text{ mV}$

Economy mode: $VDD = 1.0\text{ V} \pm 50\text{ mV}$

Speed mode: $VDD = 1.1\text{ V} \pm 50\text{ mV}$

VDD_PLL has the same core voltage range. VDD_SER and VDD_SER_PLL have a voltage range from $1.0\text{ V} \pm 50\text{ mV}$ to $1.1\text{ V} \pm 50\text{ mV}$. All voltages should be connected to noise filters.

The voltage range of GPIO banks and VDD_CLK can be set from 1.1 V to 2.7 V.

Chapter 3

Workflow and Hardware Setup

3.1 FPGA Workflow

3.1.1 Overview

The workflow from design entry to the GateMate™ FPGA configuration file is shown in Figure 3.1.

Design entry is accomplished using entry tools or any Hardware Description Language (HDL). The Yosys Open SYNthesis Suite (Yosys) [↗](#) is used to perform Register Transfer Level (RTL) synthesis. It has extensive Verilog support. VHDL sources can be synthesized via GHDL [↗](#) through the `ghdl-yosys-plugin` [↗](#). Other HDLs and tools with Verilog back-end can also be used. A guide to the synthesis options of Yosys for the GateMate techlib directory is described in Section 3.1.2.

Synthesis generates a gate-level representation of the design entry in form of a Verilog netlist of architecture-specific primitives. The resulting netlist can be used for post-synthesis simulation with any simulator. The required simulation models are part of the GateMate techlib directory in Yosys.

Furthermore, the netlist is passed to the Place & Route tool for architecture-specific implementation and bitstream generation. A netlist converter generates a generic netlist from the Yosys or legacy netlist. The first steps of Place & Route comprise procedures for speed or area optimization before mapping. After placement and routing, the static timing analysis (STA) might lead to further optimization steps and makes the Place & Route software an iterative process of constraint-driven re-placement and re-routing steps to finally achieve user requirements.

After successful placement and routing, a Verilog netlist with the associated Standard Delay Format (SDF) for timing-based post-implementation simulation are generated.

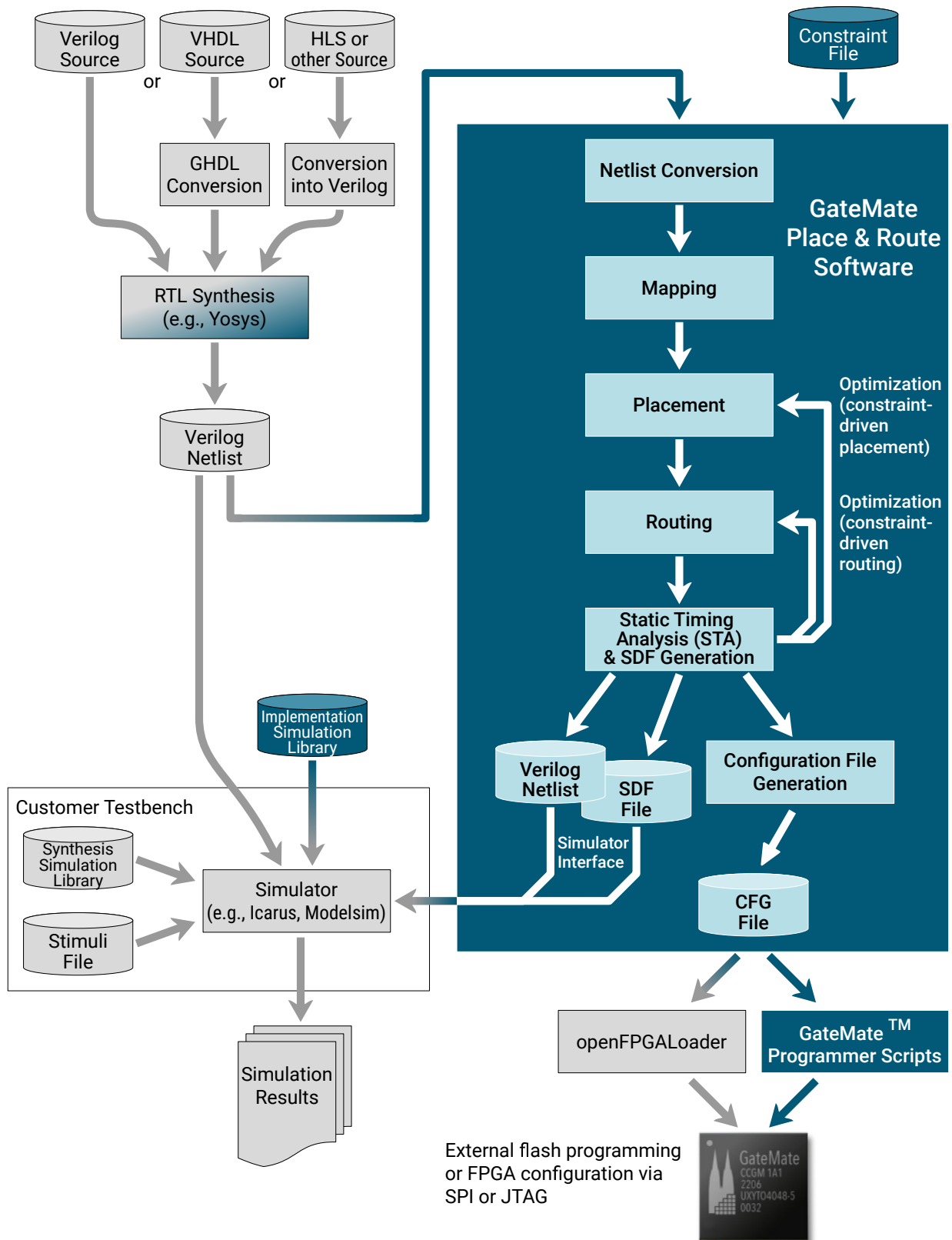

Figure 3.1: GateMate™ FPGA workflow

Simulation of the Verilog netlist requires a library of simulation models provided by Cologne Chip. Again, any simulator can be used.

The resulting configuration bitfile can either be written into a flash memory or directly to the FPGA configuration controller using its JTAG or SPI interfaces. [openFPGALoader](#) has full support for GateMate™ FPGA configuration. Alternatively, Cologne Chip offers customizable scripts for configuration. A guide to programming external flash and FPGA configuration using openFPGALoader is described in Section 3.1.4.

3.1.2 Synthesis

This section describes the architecture-specific options of the `synth_gatemate` pass in Yosys to run synthesis.

-top <module>

Uses the specified module as top-level module. In general, Yosys autodetects the top-level module within the set of input files.

-noflatten

Omits flattening of the design before synthesis. Yosys automatically flattens the netlist for efficiency. This option gives per-module synthesis statistics that can be used to discover modules in need for optimization. Note that the Cologne Chip Place & Route accepts flattened netlists only.

The following commands disable architecture-specific cells. In order to be able to use the full functionality, none of these options should be set. These options generally slow down design performance and increase area usage.

-nobram

Omits using `CC_BRAM_20K` or `CC_BRAM_40K` block RAM cells in the output netlist, forcing Yosys to build memories out of registers.

-noaddf

Omits using `CC_ADDF` full adder cells in the output netlist.

-nomult

Omits using `CC_MULT` multiplier cells in the output netlist.

-nomx8, -nomx4

Omits using `CC_MX{8, 4}` multiplexer cells in the output netlist.

-noiopad

Disables I/O buffer insertion (useful for hierarchical or out-of-context flows).

-noclkbuf

Disables automatic clock buffer `CC_BUFG` insertion.

Moreover, following synthesis-related options may be used to improve efficiency in terms of area and speed.

-luttree (experimental)

This option enables LUT-tree mapping to CC_L2T4 and CC_L2T5 cells. Mapping to LUT-trees is omitted if this parameter is not specified. Yosys then defaults to traditional LUT mapping that results in less efficient implementation results during place and route.

-retime

This option makes LUT mapping DFF-aware. It is able to remove or move registers to balance logic. Design performance benefits from that option.

In addition, there are options to call Yosys backends to write the netlist to a file.

-vlog

Writes the design to the specified Verilog file. It is used as simulation netlist or input for the Cologne Chip Place & Route. Writing of an output file is omitted if this parameter is not specified.

-json

Writes the design to the specified JSON file. It is used as input for Place & Route in nextpnr (future feature). Writing of an output file is omitted if this parameter is not specified.

3.1.3 Implementation

Place & Route Options

This section describes the available options of the Cologne Chip Place & Route to run implementation and bitstream generation. In general, the tool accepts Verilog netlists of architecture-specific primitives as generated in the `synth_gatemate` pass in Yosys. IO planning is handled with CCF constraint files.

Boolean options can be set with `+` and reset with `-` (`++` or `--` if using long option). Alternatively, `1 / 0`, `on / off` or `true / false` can be used for set and reset of an option as suffix. Option setting by suffix has priority over setting by `+/-`. E.g. `"-X on"` means option X is set.

-h, --help

Displays help information and exits.

-i <arg>, --input <arg>

Netlist input path and file name.

-lib <arg>, --lib <arg>

Specifies the library format used in the input netlist. Available libraries are {auto, ccag, xise, xvivado, yvivado}.

-o <arg>, --output <arg>

Output file name.

-ccf <arg>, --ccf <arg>

CCF constraints input path and file name.

-v, --verbose

Verbose mode.

-om <arg>, --fpga_mode <arg>

Operation mode {1:lowpower, 2:economy, 3:speed} (default: 3).

-tm <arg>, --time_mode <arg>

Timing mode {1:best, 2:typical, 3:worst} (default: 3).

The following commands control clock and optimization parameters.

-sf <arg>, --skew_factor <arg>

Skew violation factor of data path delay (default: 0.8).

+/-s, ++/--skew

Enable clock skew routing iteration (default: on).

+/-cCP, ++/--clk_CP

Use CP-lines for CPE inputs CLK and EN (default: on).

+/-gCP, ++/--gate_CP

Use CP-lines to build large gates using cascaded CPEs (default: on).

+/-cgb, ++/--clk_g1_bot

Force clocks over CP-lines from bottom edge (default: off).

+/-cgbc, ++/--g1_bot_chain

Force chaining instead of mesh in bottom edge (default: off).

+/-AF, ++/--AF

Combine adder and flip-flop functions in one CPE (default: off).

+/-dC, ++/--dual_CPE

Combine 2 gates into one CPE (default: on).

+/-sp, ++/--speed

Speed constraint (default: off).

+/-dl, ++/--del_latch

Delete latches with clamped G input (default: on).

+/-df, ++/--del_FF

Delete flip-flops with clamped set / reset inputs (default: on).

-pB <arg>, --place_box x<x1>y<y1>x<x2>y<y2>

Restricts the usable area in the CPE array, where {x1, x2} in [1..160] and {y1, y2} in [1..128].

The following commands control reports and output file parameters.

+/-ics, ++/--icarus_sdf

Generate Icarus Verilog compatible SDF (default: off).

+/-tp <arg>, ++/--time_pathes <arg>

Number of pathes in the timing report (default: 0).

+/-cdf, ++/--cdf

Write CDF file (default: on).

+/-pin, ++/--pin
Write PIN file (default: on).

+/-plc, ++/--plc
Write PLACE file (default: on).

+/-crf, ++/--crf
Generate cross reference file (default: off).

The following commands control global I/O-related parameters.

+/-CPE_in, ++/--CPE_inpin
Locate CPE next to FPGA input pin (default: off).

+/-CPE_out, ++/--CPE_outpin
Locate CPE next to FPGA output pin (default: off).

+/-uCIO, ++/--use_CFG_IOS
Use configuration I/Os as user GPIOs (default: off).

The following commands control configuration related parameters.

+/-pr, ++/--pwr_red
Reduce active power by setting unused Switch Box nodes inactive (default: on).

+/-m_spi <arg>, ++/--SPI_m_mode <arg>
SPI master settings {00:disable, 11:single, 12:dual, 14:quad} (default: 00).

+/-s_spi <arg>, ++/--SPI_s_mode <arg>
SPI slave settings {0:disable, 1:single, 4:quad} (default: 0).

CCF Constraint File Format

Entries in the CCF constraints file have the following format:

```
<pin-direction> "<pin-name>" Loc = "<pin-location>" | <opt.-constraints>;
```

Files are read line by line. Text after the hash symbol is ignored.

Available pin directions:

Pin_in defines an input pin.

Pin_out defines an output pin.

Pin_inout defines a bidirectional pin.

Additional constraints can be appended with the pipe symbol.

Available pin constraints:

SCHMITT_TRIGGER={true,false}

Enables or disables Schmitt-trigger (hysteresis) option.

PULLUP={*true,false*}

Enables or disables I/O pull-up resistor of nominal 50 k Ω .

PULLDOWN={*true,false*}

Enables or disables I/O pull-down resistor of nominal 50 k Ω .

KEEPER={*true,false*}

Enables or disables I/O keeper option.

SLEW={*slow,fast*}

Sets slew rate to slow or fast.

DRIVE={*3,6,9,12*}

Sets output driver strength to 3 mA.. 12 mA.

DELAY_IBF={*0..15*}

Adds an additional delay of n times the nominal 50 ps to the output signal.

DELAY_OBF={*0..15*}

Adds an additional delay of n times the nominal 50 ps to the input signal.

FF_IBF={*true,false*}

Enables or disables placing of flip-flops in input buffer, if possible.

FF_OBF={*true,false*}

Enables or disables placing of flip-flops in output buffer, if possible.

LVDS_BOOST={*true,false*}

Enables increased LVDS output current of 6.4 mA (default: 3.2 mA).

LVDS_RTERM={*true,false*}

Enables on-chip LVDS termination resistor of nominal 100 Ω , in input mode only.

Global I/O constraints can be set with the `default_GPIO` statement. It can be overwritten by individual settings for specific GPIOs.

```
default_GPIO | DRIVE=3; # sets all output strengths to 3mA, unless  
↔ overwritten
```

3.1.4 Configuration

This section describes the options to configure the CCGM1A1 and access external flash memory with openFPGALoader [↗](#) for the following boards and cables:

- GateMate™ FPGA Evaluation Board [↗](#)
- GateMate™ FPGA Programmer [↗](#)

Supported configuration files are bitfiles `*.bit` and it's ASCII equivalents `*.cfg` as generated from Cologne Chip Place & Route. The most useful options are listed as follows. Examples of how to use the tool are given below.

- b, --board <arg>**
Specifies board and interface: '-b gatemate_evb_jtag' or '-b gatemate_evb_spi'.
- c, --cable <arg>**
Specifies programmer cable: '-b gatemate_pgm'.
- freq <arg>**
Use the specified frequency to shift the bitstream in Hz. Append 'k' to the argument for frequency in kilohertz, or 'M' for frequency in megahertz, e.g. '--freq 10M' (default: 6M).
- f, --write-flash**
Writes the bitstream to an external flash memory.

JTAG Configuration

This mode performs an active hardware reset and writes the configuration into the FPGA latches via JTAG. The configuration mode pins CFG_MD[3:0] must be set to 0xC (JTAG mode).

Program using the evaluation board [↗](#):

```
$ openFPGALoader -b gatemate_evb_jtag <bitfile>.{cfg,bit}
```

Program using the programmer board [↗](#):

```
$ openFPGALoader -c gatemate_pgm <bitfile>.cfg.bit
```

SPI Configuration

Performs an active hardware reset and writes the configuration into the FPGA latches via SPI. The configuration mode pins CFG_MD[3:0] must be set to 0x4 (SPI passive mode).

Program using the evaluation board [↗](#):

```
$ openFPGALoader -b gatemate_evb_spi -m <bitfile>.{cfg,bit}
```

Program using the programmer board [↗](#):

```
$ openFPGALoader -b gatemate_pgm_spi -m <bitfile>.{cfg,bit}
```

JTAG Flash Access

It is possible to access external flashes via the internal JTAG-SPI bypass. The configuration mode pins CFG_MD[3:0] must be set to 0xC (JTAG mode). Note that the FPGA will not start automatically.

Write to flash using the evaluation board [↗](#):

```
$ openFPGALoader -b gatemate_evb_jtag <bitfile>.{cfg,bit}
```

Program using the programmer board [↗](#):

```
$ openFPGALoader -c gatemate_pgm -f <bitfile>.{cfg,bit}
```

The 'offset' parameter can be used to store data at any point in the flash, e.g.:

```
$ openFPGALoader -b gatemate_evb_jtag -o <offset> <bitfile>.{cfg,bit}
```

SPI Flash Access

If the programming device and the FPGA share the same SPI signals, it is possible to hold the FPGA in reset and write data to the flash. The configuration mode can be set as desired. If the FPGA should start from the external memory after reset, the configuration mode pins CFG_MD[3:0] must be set to 0x0 (SPI active mode).

Write to flash using the evaluation board [↗](#):

```
$ openFPGALoader -b gatemate_evb_spi -f <bitfile>.{cfg,bit}
```

Program using the programmer board [↗](#):

```
$ openFPGALoader -b gatemate_pgm_spi -f <bitfile>.{cfg,bit}
```

The 'offset' parameter can be used to store data at any point in the flash, e.g.:

```
$ openFPGALoader -b gatemate_evb_spi -o <offset> <bitfile>.{cfg,bit}
```

3.2 Hardware Setup

3.2.1 Power-on Reset

The GateMate™ FPGA has a reset pin RST_N with Schmitt-trigger characteristic and internal pull-up resistor. Signal polarity is active low.

The power-on reset (POR) module ensures a safe reset as soon as core voltage VDD and VDD_CLK supply voltages are stable. Figure 3.2 shows the POR block diagram. The POR module has the following features:

- Safe reset generation after stable VDD and VDD_CLK voltages.
- Voltage drop detection for VDD and VDD_CLK voltages.
- Adjustable VDD_CLK voltage threshold.
- No restrictions concerning order of voltage switch-on.
- Temperature compensated voltage reference.

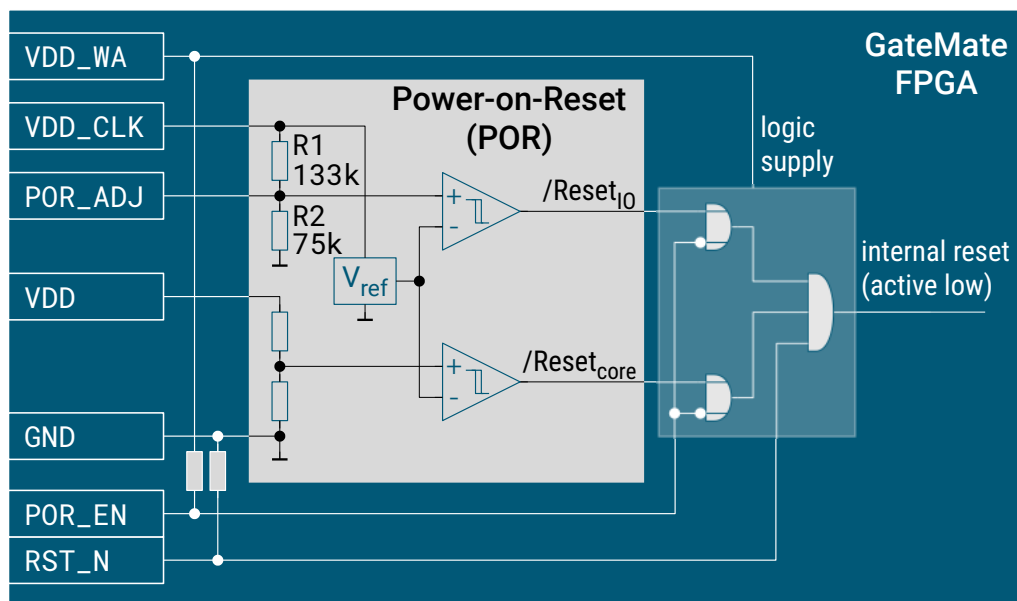

Figure 3.2: Power-on reset (POR) module block diagram

The POR must be enabled with POR_EN signal:

- 0: Reset state depends only on the RST_N signal.
- 1: FPGA changes from reset to operation state when RST_N is 1 and POR indicates VDD and VDD_CLK voltages are stable.

POR_EN has an internal pull-down resistor and can be left open if not used.

Figure 3.3 shows an exemplary supply voltage curve to explain the operation behavior of the POR reset output signals. Please see the electrical specification given in Table 4.6 on page 96 for exact threshold values in different operating cases.

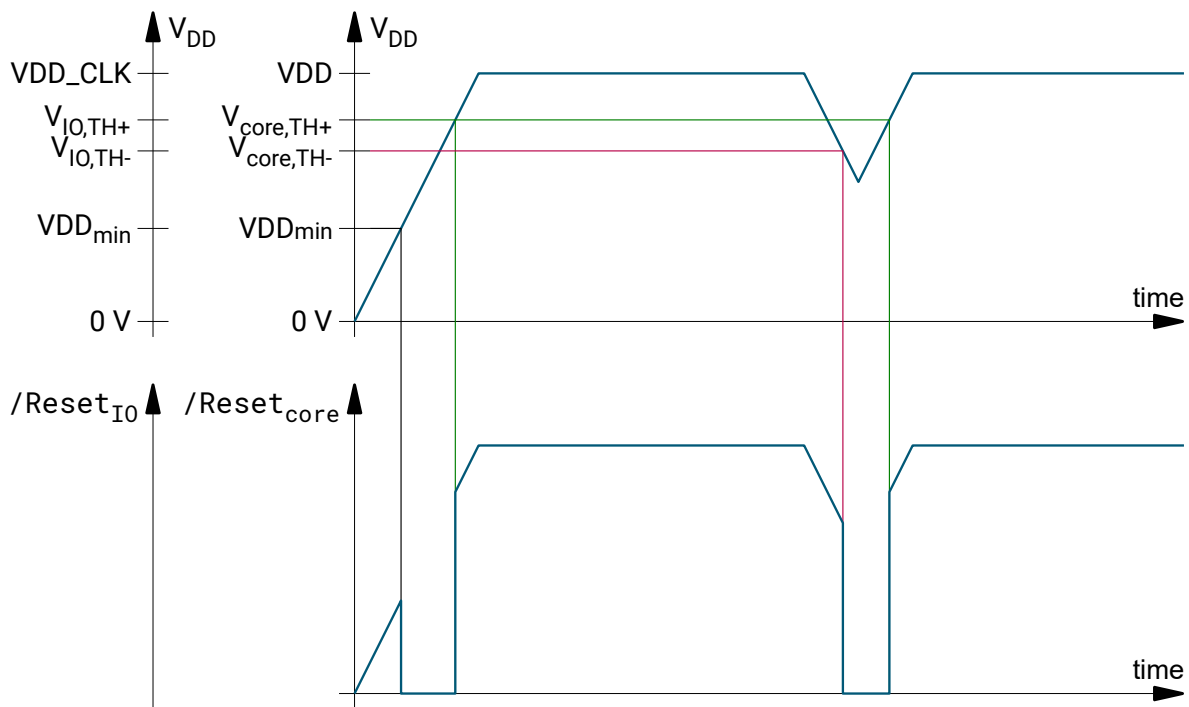

Figure 3.3: Threshold principles of POR

3.2.2 FPGA reset using the POR module

Using the POR module, in many cases no external components are required to ensure a safe reset of the GateMate FPGA. Figure 3.4 shows how to connect the reset pins in this case:

- VDD_WA and VDD_CLK must be connected to 1.1..2.7V supply (might be different).
- POR_EN has to be connected to VDD_WA or it can be left open due to the internal pull-up resistor.
- Pin RST_N must be connected to VDD_CLK.
- In normal operation, POR_ADJ should be left open. The optional voltage divider R3a and R3b is only used, if POR adjustment is required. This depends on the VDD_CLK level (see explanation below).

POR adjustment:

- With VDD_CLK in the range 1.8..2.7V (normal operation), POR_ADJ should be left open.
- R3b will increase the threshold level. Typically, this is not necessary within the specified VDD_CLK supply range. Nevertheless, reset state is permanently set with $R3b \leq 100 \text{ k}\Omega$.
- R3a will decrease the threshold level. This is only necessary when $VDD_CLK < 1.8 \text{ V}$ to avoid a permanent reset state. There will be no reset condition when $R3a \leq 100 \text{ k}\Omega$.

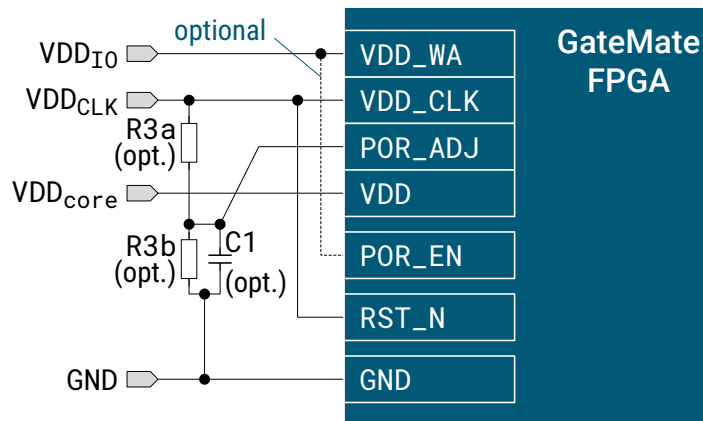

Figure 3.4: FPGA reset using the POR module

- For very low VDD_CLK voltages only a dynamic reset generation by means of R3a and C1 circuitry is possible. POR_ADJ is temporarily kept at ground level by C1. After charging C1 via R3a, the reset is released. The reset time can be approximated by

$$t_{\text{reset}} = \frac{R3a \cdot 75 \text{ k}\Omega}{R3a + 75 \text{ k}\Omega} \cdot C1 \cdot \ln \left(\frac{VDD_CLK}{VDD_CLK - \frac{0.45 \text{ V}}{75 \text{ k}\Omega} \cdot \left(75 \text{ k}\Omega + \frac{R3a \cdot 133 \text{ k}\Omega}{R3a + 133 \text{ k}\Omega} \right)} \right)$$

for $R3a < 10 \text{ k}\Omega$ this can be simplified to

$$t_{\text{reset}} \approx R3a \cdot C1 \cdot \ln \left(\frac{VDD_CLK}{VDD_CLK - 0.45 \text{ V}} \right)$$

The reset time should be adjusted to the slope time of the VDD_CLK ramp-up.

3.2.3 FPGA reset without POR module

If the POR module is not to be used (see Figure 3.5), the following settings are required:

- VDD_WA and VDD_CLK must be connected to 1.1.. 2.7V supply (might be different).
- POR_EN has to be connected to GND.
- POR_ADJ can be left open.
- Pin RST_N must be connected to a logic or RC circuit to ensure a rising edge after stable power supply.

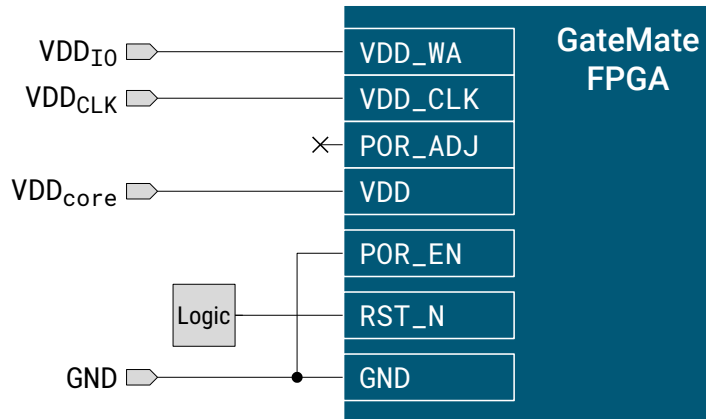

Figure 3.5: FPGA reset driven by an external logic

3.3 Configuration Procedure

3.3.1 Configuration Modes

The GateMate™ FPGA can be configured from four different sources:

1. The configuration process is controlled by the FPGA itself where it acts in SPI active mode, e.g., after reset. Configuration data is read from an external flash memory.
2. A processor unit operating as SPI in active mode feeds the configuration data to the FPGA which acts in SPI passive mode.
3. The JTAG interface of the FPGA connects to a JTAG test & programming adapter.
4. User configured logic of the FPGA can feed configuration data to the FPGA itself.

With the rising edge of the reset signal the configuration mode setup at pins CFG_MD[3:0] gets captured as shown in Table 3.1. These pins must always be connected to either GND or VDD_WA.

Table 3.1: Configuration mode setup

CFG_MD[3:0] *		Configuration mode	
0x0	0b0000	SPI Active Mode	CPOL = 0, CPHA = 0
0x1	0b0001	SPI Active Mode	CPOL = 0, CPHA = 1
0x2	0b0010	SPI Active Mode	CPOL = 1, CPHA = 0
0x3	0b0011	SPI Active Mode	CPOL = 1, CPHA = 1
0x4	0b0100	SPI Passive Mode	CPOL = 0, CPHA = 0
0x5	0b0101	SPI Passive Mode	CPOL = 0, CPHA = 1
0x6	0b0110	SPI Passive Mode	CPOL = 1, CPHA = 0
0x7	0b0111	SPI Passive Mode	CPOL = 1, CPHA = 1
0xC	0b1100	JTAG	

* Modes not mentioned in the list may not be selected and lead to a malfunction of the device.

3.3.2 Configuration Signals

Table 3.2: Configuration signal bank

Pin	Signal name	Reset category	I/O mode	I/O characteristic	Description
R5	CFG_MD0	4	I		Configuration mode bit 0
T5	CFG_MD1	4	I		Configuration mode bit 1
U4	CFG_MD2	4	I		Configuration mode bit 2
V4	CFG_MD3	4	I		Configuration mode bit 3
U1	POR_EN	2	I	pull-down	Enable power-on reset
V3	CFG_DONE	2	O	pull-down, low, driver strength 12 mA	Configuration done signal
V2	CFG_FAILED_N	2	I/O	pull-up, high, open drain, driver strength 12 mA	Configuration failed signal
N3	SPI_CS_N	3	I, I/O	pull-up, driver strength 12 mA	Configuration SPI chip select
N4	SPI_CLK	3	I, I/O	driver strength 12 mA	Configuration SPI clock
P2	SPI_D0	3	I, I/O	driver strength 12 mA	Configuration SPI data bit 0
P1	SPI_D1	4	I		Configuration SPI data bit 1
R2	SPI_D2	4	I		Configuration SPI data bit 2
R1	SPI_D3	4	I		Configuration SPI data bit 3
R4	SPI_FWD	2	O	low, driver strength 12 mA	Configuration SPI data forward
T3	JTAG_TMS	4	I		JTAG test mode select
R3	JTAG_TCK	4	I		Configuration JTAG clock
T2	JTAG_TDI	4	I		JTAG data input
U2	JTAG_TDO	2	O	low, driver strength 12 mA	JTAG data output

Reset categories:

0: No reset (supply or analog input pin)

1: Pin disabled, high-z

2: Pin characteristic already during reset state

3: Pin characteristic depends on the configuration mode (SPI master: I/O, else: input)

4: Input pin

3.3.3 SPI Configuration

The SPI bus of GateMate™ FPGA can be used to load the configuration either in SPI active or passive mode. Both modes use the same pins. Typically, a flash memory is connected to the SPI bus to provide the configuration data. Figure 3.6 shows a typical circuitry which uses only single-I/O or dual-I/O mode. The flash signals I/O₂ and I/O₃ can have further functions depending on the used device and should have pull-up resistors in most cases.

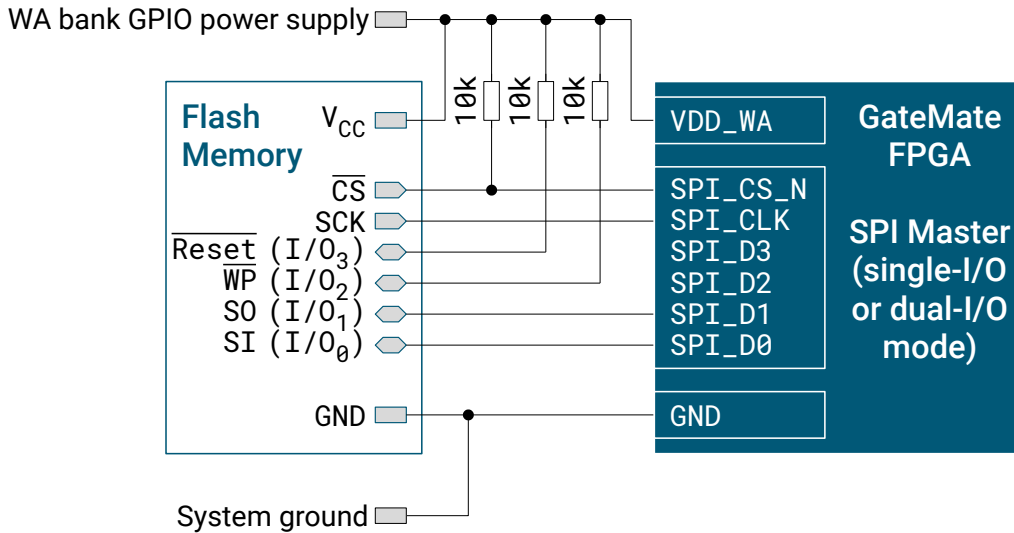

Figure 3.6: Configuration data from flash memory in SPI single-I/O or dual-I/O mode

When SPI quad-I/O mode is used, Figure 3.7 shows the typical circuitry. Now, all data lines are connected and no pull-up resistors are required. Depending on the used flash device, pull-up resistors are recommended at I/O₂ and I/O₃ signals.

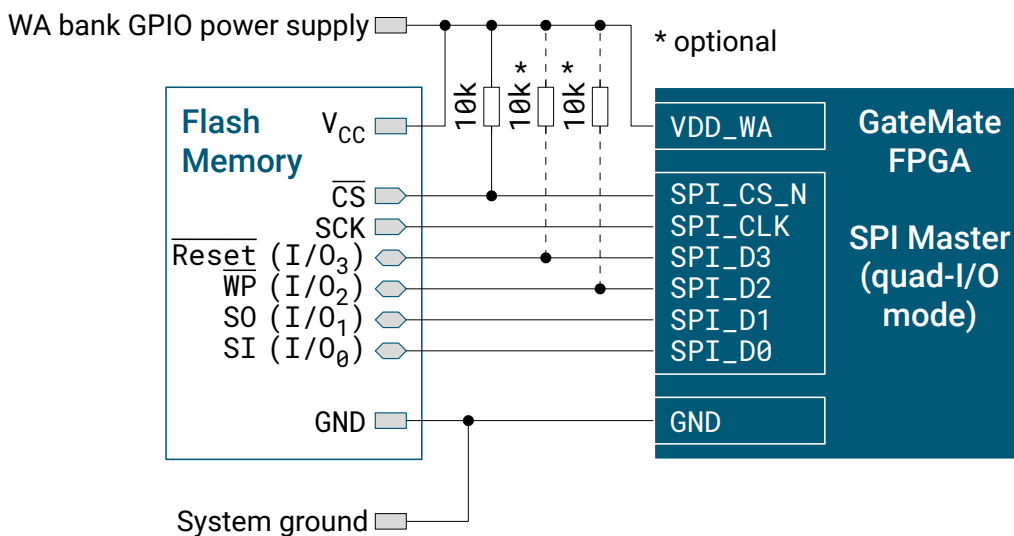

Figure 3.7: Configuration data from flash memory in SPI quad-I/O mode

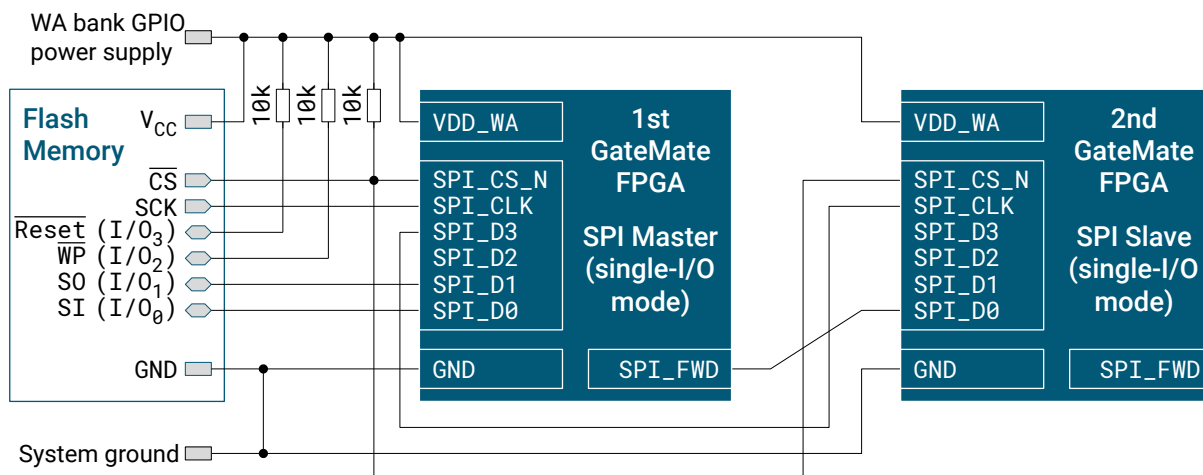

Figure 3.8: Configuration data stream from a single flash memory

Finally, Figure 3.8 shows two GateMate™ FPGAs using the same SPI configuration data source. This is done using the SPI forward function. Only SPI single-I/O mode can be used in this case. In a multi-chip setup multiple FPGAs are configured in a chain.

The GateMate™ FPGA is able to load its configuration automatically after reset. No external clock is required. When SPI active Mode is set up, the rising edge of RST_N starts reading the configuration data from the flash memory. The internal clock needs no external reference clock. If an external reference clock is available, the configuration stream can set up a phase-locked loop (PLL) to any configuration clock frequency.

When operating in SPI active mode, error detection and correction is done automatically. In this case a short CFG_FAILED_N pulse is given and the failed configuration sequence will be re-read.

When operating in SPI passive mode, the configuration controller can only react on the incoming data stream while the external device in SPI active mode is in control over the bus.

The signals CFG_DONE and CFG_FAILED_N indicate the end of the configuration process as described in Table 3.3.

Table 3.3: Configuration process state

CFG_DONE	CFG_FAILED_N	Description
0	0*	Invalid state
0	1	Configuration procedure is still in progress
1	0*	Unable to load configuration. Data stream might be invalid
1	1**	Configuration successful

* Only long CFG_FAILED_N pulses. Short pulses have no significance.

** CFG_DONE might not be retrievable in case the configuration bank is set to user mode.

CFG_FAILED_N requires a pull-up resistor. If multiple FPGAs are configured from a single flash memory, all CFG_FAILED_N have to be connected as shown in Figure 3.9.

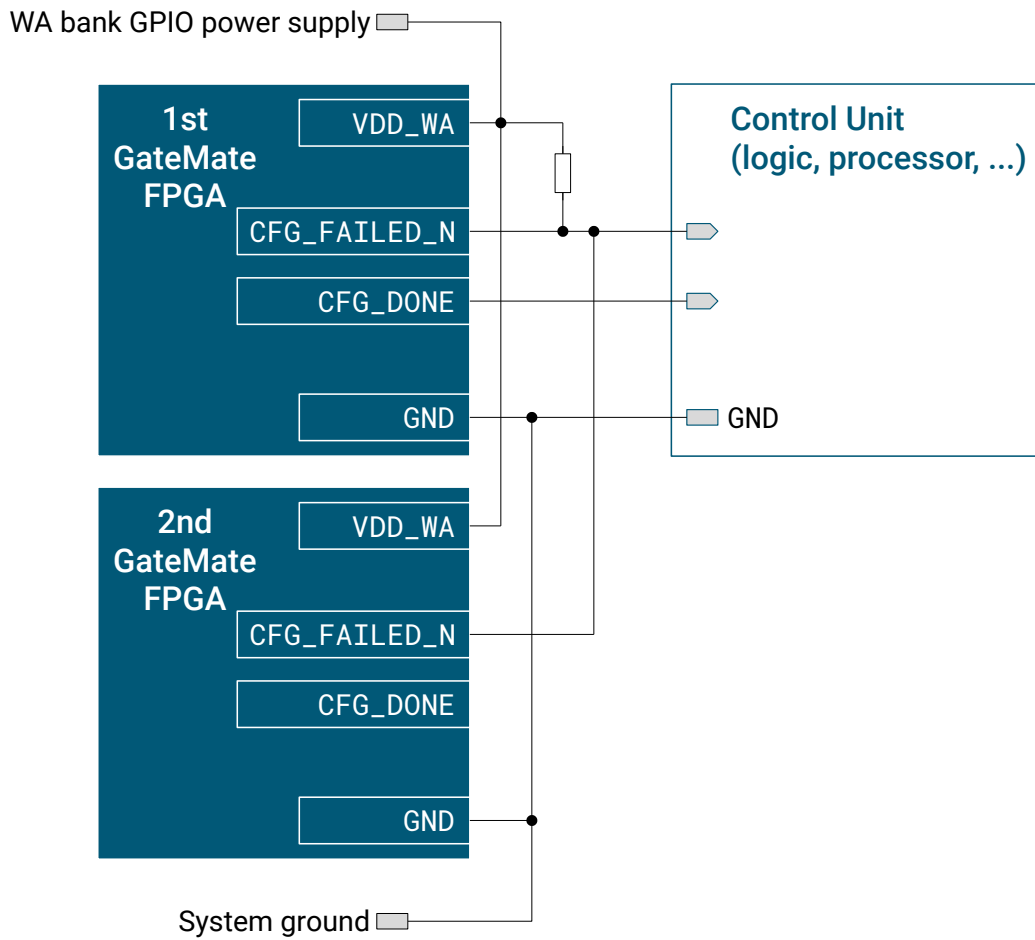

Figure 3.9: Connection of CFG_DONE and CFG_FAILED_N signals in multi-FPGA applications with a single flash memory

3.4 JTAG Interface

3.4.1 JTAG overview

The GateMate™ FPGA configuration bank provides a standard IEEE 1149.1-2001 compliant Test Access Point (TAP) that can be used for the following functions:

- Load configuration via JTAG¹
- Full access to SPI interface using JTAG-SPI bypass
- Utilities to access external SPI data flashes
- Boundary-Scan Testability: SAMPLE / PRELOAD and EXTEST
- Access to supplementary internal registers

Figure 3.10 illustrates the typical wiring between a single FPGA and a JTAG host controller. By connecting devices via the data input and output signals it is possible to chain multiple TAPs in a serial configuration. The operating range of the supply voltage on the configuration bank is shown in Table 4.3. The JTAG interface is always available after global reset. It will no longer be available once the configuration bank is switched to user I/O after configuration.

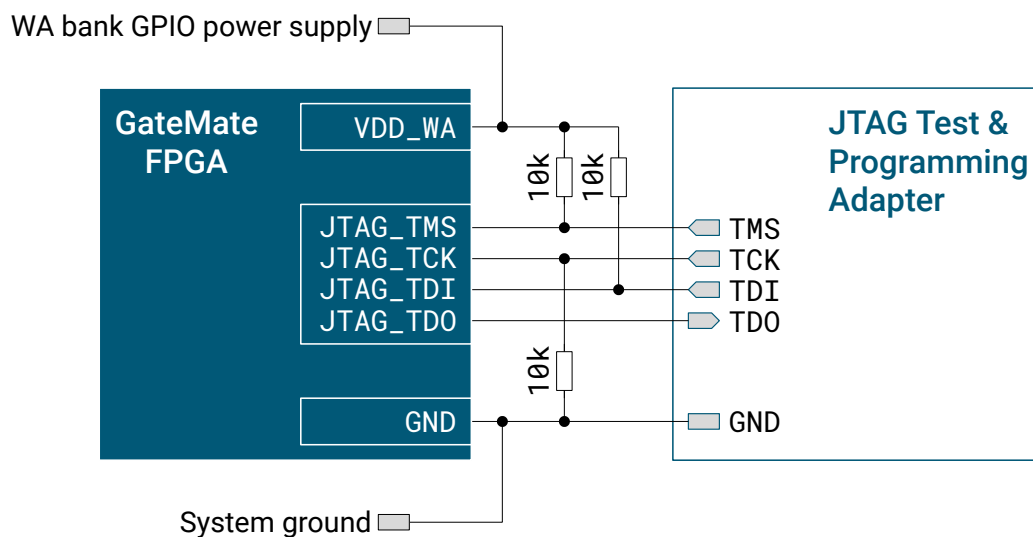

Figure 3.10: JTAG connection scheme

Four signals support the TAP according to the IEEE 1149.1-2001 requirements:

Test Mode Select (TMS) controls the TAP controller state machine. The signal is sampled on the rising edge of TCK.

Test Clock (TCK) provides a clock signal. TMS is sampled on the rising edge of TCK. Input data on TDI is shifted into the instruction (IR) or data (DR) registers on the rising edge of TCK. Output data on TDO is shifted out on the falling edge of TCK.

¹ See Section 3.3.1 for more ways to load the FPGA configuration.

Test Data Input (TDI) is the serial input to all JTAG instruction (IR) and data (DR) registers depending on the sequence previously applied at TMS.

Test Data Output (TDO) is the serial output for all JTAG instruction (IR) and data (DR) registers depending on the sequence previously applied at TMS.

3.4.2 JTAG Usage

The TMS signal is evaluated on the rising edge of TCK. Its value decides the next state into which the finite-state machine (FSM) changes. The FSM states are shown in Figure 3.11.

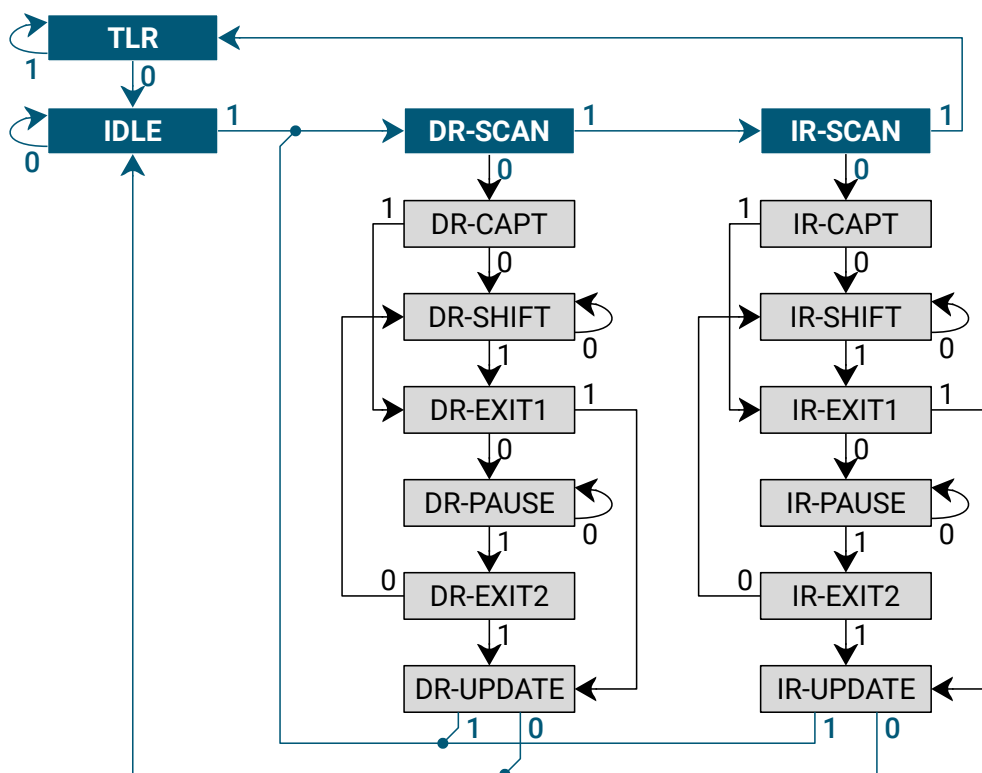

Figure 3.11: Finite-state machine of the JTAG interface

The typical procedure is to first load the instruction and then write or read the data associated with this instruction. The JTAG host controller must drive the signals TCK, TMS and TDI in the according way as illustrated shown in Figures 3.12 and 3.13. The instruction register (IR) size is 6 bits. Instructions have to be shifted into the JTAG TAP with least significant bit (LSB) first.

3.4.3 Common JTAG Instructions

According to IEEE 1149.1-2001, the IDCODE register is optional and thus only contains a placeholder value.

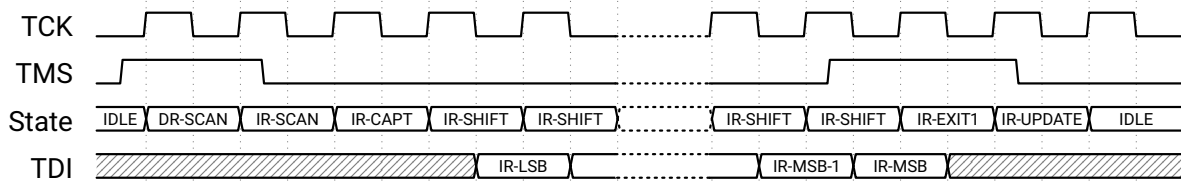

Figure 3.12: JTAG instruction shift *NEW COMMAND*

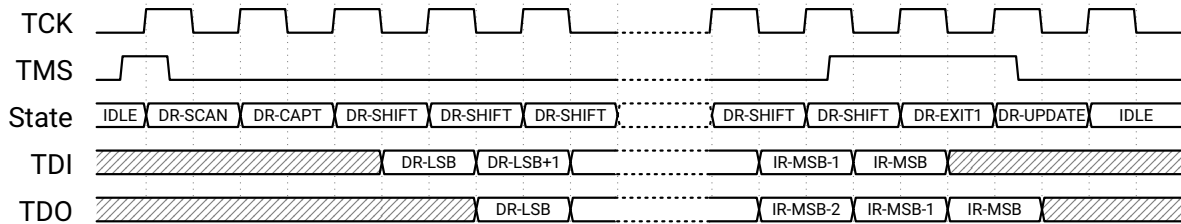

Figure 3.13: JTAG data shift

The bypass mode connects the JTAG TDI and TDO lines via a single-bit pass-through register and allows the testing of other devices in a JTAG chain. In bypass mode, the TDI input is delayed by one clock cycle before outputting to TDO.

Instruction: $0x3F$ **JTAG_BYPASS** **Shift width:** 1 bit

Configure JTAG bypass mode. The bypass register is set to zero when the TAP controller is in the CAPTURE-DR state.

Shift-in bits: -

Shift-out bits: - Input bit pattern delayed by one clock cycle.

3.4.4 JTAG Configuration

The JTAG interface can be used to configure the FPGA as well. The configuration stream must have a length of a multiple of 8 bits. The JTAG TAP automatically combines every 8 received bits to a single byte and forwards it to the configuration processing block. JTAG configuration works independently of the configuration mode pins $CFG_MD[3:0]$. However, in order to avoid conflicts, the pins should be set to $0xC$. Further information on the configuration modes can be found in Section 3.3.1. The configuration byte stream is in big endian while the bytes are in little endian. If the configuration bank is not switched to user I/O after configuration, the status can be read as usual using the CFG_DONE and CFG_FAILED_N pins.

Instruction:	0x 06	JTAG_CONFIGURE	Shift width:	M · 8 bits
Configure the FPGA with a configuration stream of M bytes.				
Shift-in bits:	M · [7 : 0]	The configuration byte stream is in big endian while the bytes are in little endian.		
Shift-out bits:	M · [7 : 0]	Don't care		

3.4.5 Access to SPI Bus

The SPI bus can be accessed directly using the JTAG interface. This way, bitstreams may be written to an external data flash without having to access the bus with additional hardware. There are two ways of acting on the SPI bus via the JTAG interface:

- Full access to SPI interface using JTAG-SPI bypass
- Utilities to access external SPI data flashes

Figure 3.14 illustrates the wiring between a single FPGA connected to an external SPI component and a JTAG host controller.

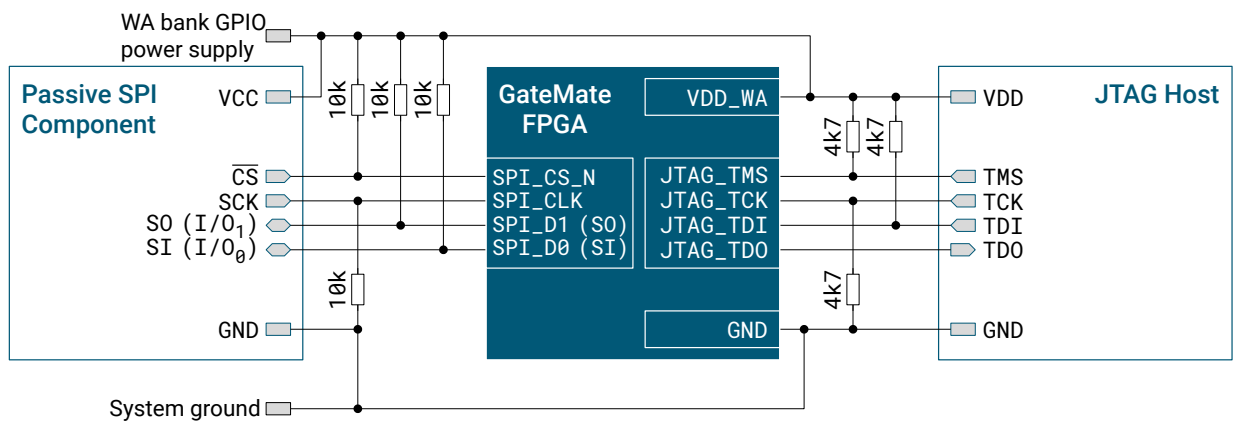

Figure 3.14: JTAG-SPI bypass connection scheme

In active JTAG-SPI bypass mode all JTAG signals JTAG_TCK, JTAG_TDI and JTAG_TDO are directly connected to the SPI pins. Due to the direct connection of JTAG_TCK and SPI_CLK, the clock frequency on the SPI bus is the same as that of the JTAG clock. Before accessing the SPI bus via active bypass it must be ensured that the SPI bus is not busy, e.g., by checking the JTAG_GET_SPI_BUSY command. There is no restriction on the length of a SPI transfer. The SPI bypass mode works for all four SPI modes (CPOL, CPHA), but only in single-IO mode as set via the SPI configuration mode pins CFG_MD [1 : 0] described in Table 3.1.

With each DR-shift one bit at JTAG_TDI is shifted into the JTAG TAP and directly forwarded to SPI_D0 output. Simultaneously, one bit is shifted into SPI_D1 input. The bit

will be available on the JTAG output JTAG_TDO at the next falling edge of JTAG_TCK. There must be one more DR-shift cycle than bits to transmit. The last bit shifted into the TAP will not be shifted to the external SPI device and the very first bit shifted out of the TAP is an invalid bit.

Instruction:	0x 05	JTAG_SPI_BYPASS	Shift width:	N bits
Active access to SPI bus via JTAG.				
Shift-in bits:	- Data to be shifted into external SPI device			
Shift-out bits:	- Data to be shifted from external SPI device			

Figure 3.15 illustrates the function of the active JTAG-SPI bypass in all four available SPI single-IO modes.

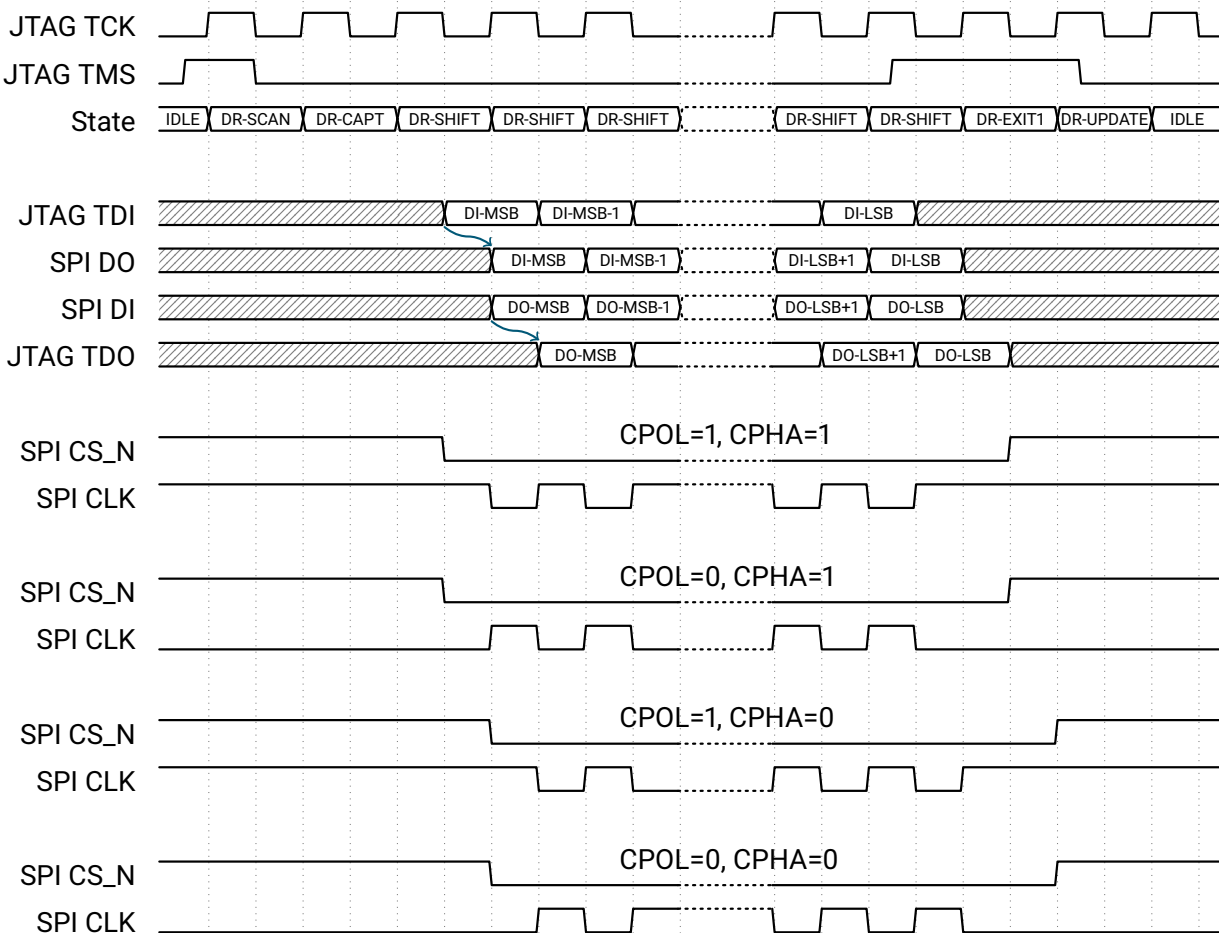

Figure 3.15: Timing diagram of the JTAG-SPI bypass mode.

3.4.6 Access to SPI data flash

The JTAG_SPI_ACCESS provides access to external SPI data flashes with a conventional command structure, in which command, mode, address and bidirectional data bits can be exchanged. In order to support a wide range of SPI data flashes, all command fields can be adjusted. First, the instructions have to be shifted into the JTAG TAP register with LSB first. The actual SPI transfer starts as soon as the DR-UPDATE state in JTAG FSM was executed. In contrast to the JTAG-SPI bypass mode, the SPI clock rate is determined by the clock frequency of the internal oscillator. Access to external SPI data flashes works for all four SPI modes (CPOL, CPHA), but only in single-IO mode. The mode is again indicated by the configuration mode pins CFG_MD[1:0] as described in Table 3.1. Setting CFG_MD2 to one ensures the controller to be in SPI active mode.

The JTAG_SPI_ACCESS command allows transmissions of at most 32 TX data bits. The number of TX bits must be specified and TX words must be set to 1. Moreover, up to 32 bits of data can be received via the JTAG_GET_SPI_RXDATA command after execution of JTAG_SPI_ACCESS with the corresponding read command and number of bits to be received. The RX data flag is only valid if the read command was previously executed.

In order to transfer more than 32 bits, the JTAG TAP contains a register file of 256 bytes that can be filled via the JTAG command JTAG_FLASH_PAGE_PREP before the execution of an JTAG_SPI_ACCESS with a number of TX data word greater than 1. The total number of bits to be transmitted from the register file is the product of TX data bits times TX data words. The internal file register for transmitting more than 32 bits contains a 256 byte memory that can be pre-loaded by using the JTAG_FLASH_PAGE_PREP command. An entire 32-bit word must always be followed by a DR-UPDATE. This procedure can be repeated up to 64 times to load a full page of 256 bytes. As long as no test logic reset command is executed, the file register retains its content, but can be overwritten. Its address counter is set to zero each time the command is called. For correct functioning it is necessary to transmit the first word of the register file again during JTAG_SPI_ACCESS.

It is highly recommended to verify the idle state before accessing the SPI bus by executing the JTAG_GET_SPI_BUSY command.

Instruction:	0x 01	JTAG_SPI_ACCESS	Shift width: 119 bits
Access external SPI data flash via JTAG.			
Shift-in bits:	[118 : 115]	Number of command bits to be shifted to SPI data flash	
	[114 : 109]	Number of address bits to be shifted to SPI data flash	
	[108 : 105]	Number of mode bits to be shifted to SPI data flash	
	[104 : 99]	Number of TX data bits to be shifted to SPI data flash	
	[98 : 92]	Number of TX data words to be shifted to SPI data flash	
	[91 : 86]	Number of dummy cycles to be shifted to SPI data flash	
	[85 : 80]	Number of RX data bits to be shifted to SPI data flash	
	[79 : 72]	Command to be transferred to SPI data flash	
	[71 : 64]	Mode to be transferred to SPI data flash	
	[63 : 32]	Address to be transferred to SPI data flash	
	[31 : 0]	TX data word to be transferred to SPI data flash. The byte stream is in big endian while the bytes are in little endian. Must contain the first word when transmitting data using the JTAG_FLASH_PAGE_PREP command.	
Shift-out bits:	[118 : 0]	Don't care	

Instruction:	0x 02	JTAG_FLASH_PAGE_PREP	Shift width: $K \cdot 32$ bits
Load data for writing up to one 256-byte flash page into FPGA. Must be followed by 0x 1 – JTAG_SPI_ACCESS.			
Shift-in bits:	$K \cdot [31 : 0]$	K 32-bit words to be written to one page in the SPI data flash with $1 \leq K \leq 64$. Each word must be followed by a DR-UPDATE. The byte stream is in big endian while the bytes are in little endian.	
Shift-out bits:	$K \cdot [31 : 0]$	Don't care	

Instruction:	0x03	JTAG_GET_SPI_RXDATA	Shift width:	33 bits
Get data read from SPI data flash via after 0x1 – JTAG_SPI_ACCESS.				
Shift-in bits:	[32 : 0]	Don't care		
Shift-out bits:	[32 : 1]	RX data read from SPI data flash		
	[0]	RX data valid flag. Only true if the preceding command was JTAG_SPI_ACCESS.		

Instruction:	0x04	JTAG_GET_SPI_BUSY	Shift width:	1 bit
Checks if the SPI controller is busy. Recommended to use before any SPI access.				
Shift-in bits:	[0 : 0]	Don't care		
Shift-out bits:	[0 : 0]	Obtain SPI bus state:		
		0b 0: SPI idle		
		0b 1: SPI busy		

3.4.7 Boundary-Scan Test

A JTAG IEEE 1149.1-2001 compliant boundary-scan allows to test pin connections without physically probing pins by shifting a boundary-scan register that is composed of cells connected between the FPGA logic and IOs.

The SAMPLE instruction allows to take a snapshot of the input and output signal states without interfering with the device pins. The snapshot is taken on the rising edge of JTAG_TCK in the DR-CAPT state. The data can then be accessed by shifting through the JTAG_TDO output.

The PRELOAD instruction allows scanning of the boundary-scan register without causing interference to the FPGA logic. It allows an initial pattern to be shifted into the boundary-scan register cells.

Both instructions SAMPLE and PRELOAD are combined in the JTAG_SAMPLE_PRELOAD command. While preloading the boundary-scan register cells by shifting data into the input JTAG_TDI the sample results are shifted through the JTAG_TDO output.

The EXTEST instruction allows access to the external circuitry through the device pins. The boundary-scan register cells connected to the output pins are used to apply test stimuli, while those at the input pins capture external signals from the device pins.

The boundary-scan register length is 317 bits. To enable boundary-scan test, the test-mode register must be set first by using the JTAG_SET_TESTMODE instruction. Please refer to the official Boundary Scan Description Language (BSDL) files for more information.

Instruction:	0x 20	JTAG_SET_TESTMODE	Shift width:	2 bits
Set value in testmode register.				
Shift-in bits:	[1 : 0]	Testmode to be set: 0b 00: Disable testmode 0b 01: reserved 0b 10: reserved 0b 11: Boundary-Scan Test		
Shift-out bits:	[1 : 0]	Don't care		

Instruction:	0x 3D	JTAG_SAMPLE_PRELOAD	Shift width:	317 bits
Boundary-scan SAMPLE and PRELOAD instruction. The register 0x 20 – Set Testmode must be set to 0b 11.				
Shift-in bits:	[316 : 0]	Preload value for boundary-scan shift register.		
Shift-out bits:	[316 : 0]	Sample value of boundary-scan shift register.		

Instruction:	0x 3E	JTAG_EXTEST	Shift width:	317 bits
Boundary-scan EXTEST instruction. The register 0x 20 – Set Testmode must be set to 0b 11.				
Shift-in bits:	[316 : 0]	Don't care.		
Shift-out bits:	[316 : 0]	Value of boundary-scan shift register.		

Chapter 4

Electrical Characteristics

Table 4.1: Absolute maximum ratings

Symbol	Min	Typ	Max	Unit	Description
	-40		125	°C	Junction temperature
VDD _{IO}			2.75	V	I/O supply voltage (GPIO banks and VDD_CLK)
VDD _{core}			1.20	V	Core supply voltage (VDD, VDD_PLL, VDD_SER and VDD_SER_PLL)
V _{ESD}			4000	V	HBM ESD class 2

Table 4.2: Operation range

Symbol	Min	Typ	Max	Unit	Description
	-20		85	°C	Operating temperature
VDD _{low power}	0.85	0.9	0.95	V	Core supply voltage (VDD, VDD_PLL) in low power mode
VDD _{economy}	0.95	1.0	1.05	V	Core supply voltage (VDD, VDD_PLL) in economy mode
VDD _{speed}	1.05	1.1	1.15	V	Core supply voltage (VDD, VDD_PLL) in speed mode
VDD _{SER}	0.95		1.15	V	SerDes supply voltage (VDD_SER)
VDD _{SER_PLL}	0.95		1.15	V	SerDes PLL supply voltage (VDD_SER_PLL)

Table 4.3: GPIO characteristics in single-ended mode

Symbol	Min	Typ	Max	Unit	Description
$V_{DD_{IO}}$	1.1		2.7	V	I/O supply voltage (GPIO banks and VDD_CLK)
V_{IN}	-0.4		$V_{DD_{IO}} + 0.4$	V	Input voltage range
Schmitt-trigger function disabled:					
V_{IH}	0.43		0.51	$V_{DD_{IO}}$	Input high threshold voltage
V_{IL}	0.45		0.51	$V_{DD_{IO}}$	Input low threshold voltage
V_{HYST}		0		V	Hysteresis
Schmitt-trigger function enabled:					
V_{IH}	0.61		0.67	$V_{DD_{IO}}$	Input high threshold voltage
V_{IL}	0.31		0.39	$V_{DD_{IO}}$	Input low threshold voltage
V_{HYST}	0.26		0.33	$V_{DD_{IO}}$	Hysteresis
Output driver disabled:					
I_{IL}			1	μA	Input pin current when driven active low
I_{IH}			1	μA	Input pin current when driven active high
R_{PU}		50		$k\Omega$	Pull-up resistance
R_{PD}		50		$k\Omega$	Pull-down resistance
$I_{DD, max}$			158	μA	Maximum supply current at GPIO input at transition point

Table 4.4: GPIO characteristics in LVDS mode

Symbol	Min	Typ	Max	Unit	Description
$V_{DD_{IO}}$	1.62		2.75	V	I/O supply voltage
I_{out}		3.2		mA	Output current when LVDS output current boost is set to nominal current
I_{out}		6.4		mA	Output current when LVDS output current boost is set to increased output current
$V_{CM_{TX}}$		$V_{DD_{IO}}/2$		V	Common-mode voltage
R_{term}	90	100	130	Ω	

Table 4.5: *PLL characteristics*

Symbol	Min	Typ	Max	Unit	Description
t_{lock}			1100	Number of ref. clock cycles	Lock in time (coarse tune, fast-lock mode) with lock detection
t_{lock}			57	Number of ref. clock cycles	Lock in time (coarse tune, fast-lock mode) without lock detection
$f_{DCO, low\ power}$	500		1000	MHz	DCO frequency in low power mode
$f_{DCO, economy}$	1000		2000	MHz	DCO frequency in economy mode
$f_{DCO, speed}$	1250		2500	MHz	DCO frequency in speed mode
$T_{DCO, step}$			10	ps	DCO period tuning step size
$f_{PLL, low\ power}$			250	MHz	PLL output frequency in low power mode
$f_{PLL, economy}$			312.5	MHz	PLL output frequency in economy mode
$f_{PLL, speed}$			416.75	MHz	PLL output frequency in speed mode

Table 4.6: Reset characteristics

Symbol	Min	Typ	Max	Unit	Description
V_{DD}	0.85	1.0	1.15	V	Core supply voltage
$V_{core,TH+}$	0.62	0.72	0.80	V	High reset threshold voltage
$V_{core,TH-}$	0.56	0.62	0.71	V	Low reset threshold voltage
$V_{core,hyst}$	60	82	96	mV	Hysteresis voltage
SR_{core}	1.8		180	V/ms	Supply voltage slew rate
VDD_{CLK}	$1.80 \pm 10\%$		$2.50 \pm 10\%$	V	VDD_CLK supply voltage
=	1.62		2.75	V	
$V_{IO,TH+}$	1.21	1.44	1.56	V	High reset threshold voltage ¹
	1.01	1.18	1.34	V	ditto ²
	0.95	1.08	1.20	V	ditto ³
$V_{IO,TH-}$	1.00	1.20	1.35	V	Low reset threshold voltage ¹
	0.89	1.06	1.19	V	ditto ²
	0.88	0.98	1.05	V	ditto ³
$V_{IO,hyst}$	152	180	215	mV	Hysteresis voltage ¹
	108	126	177	mV	ditto ²
	85	100	110	mV	ditto ³
SR_{IO}	1.8		180	V/ms	Supply voltage slew rate

¹ No level adjustment, POR_ADJ open.

² Level adjustment with R3a = 500 kΩ.

³ Level adjustment with R3a = 250 kΩ.

Chapter 5

Pinout

5.1 CCGM1A1 324-Ball FBGA Pinout

The GateMate™ FPGA CCGM1A1 has a 18×18 pin 0.8 mm fine pitch Ball Grid Array (FBGA) package with 324 balls.

General purpose input / output (GPIO) ball arrangement is defined for 4-layer printed circuit board (PCB) layout with only 2 signal layers.

	1	2	3	4	5	6	7	8	9	10	11	12	13	14	15	16	17	18	
A	GND	VDD_WC	IO_NA_A0	IO_NA_A1	VDD_NA	IO_NA_A4	GND	IO_NA_A7	IO_NB_B0	GND	IO_NB_B2	IO_NB_B4	GND	IO_NB_B7	IO_EB_B8	VDD_EB	IO_EB_B5	GND	A
B	IO_WC_A8	IO_WC_B8	IO_NA_B0	IO_NA_B1	IO_NA_A2	IO_NA_B4	VDD_NA	IO_NA_B7	IO_NB_A0	VDD_NB	IO_NB_A2	IO_NB_A4	VDD_NB	IO_NB_A7	IO_EB_A8	GND	IO_EB_A5	VDD_EB	B
C	GND	VDD_WC	IO_WC_A7	IO_WC_B7	IO_NA_B2	IO_NA_A3	IO_NA_A5	IO_NA_A6	IO_NA_A8	IO_NB_B1	IO_NB_B3	IO_NB_B5	IO_NB_B6	IO_NB_B8	IO_EB_B7	IO_EB_B6	IO_EB_B4	IO_EB_A4	C
D	IO_WC_A5	IO_WC_B5	IO_WC_A6	IO_WC_B6	VDD_WC	IO_NA_B3	IO_NA_B5	IO_NA_B6	IO_NA_B8	IO_NB_A1	IO_NB_A3	IO_NB_A5	IO_NB_A6	IO_NB_A8	IO_EB_A7	IO_EB_A6	IO_EB_B2	IO_EB_A2	D
E	IO_WC_A3	IO_WC_B3	IO_WC_A4	IO_WC_B4	GND	VDD_NA	GND	VDD_NA	GND	VDD_NB	GND	VDD_NB	GND	VDD_EB	IO_EB_B3	IO_EB_A3	VDD_EB	GND	E
F	GND	VDD_WC	IO_WC_A2	IO_WC_B2	VDD_WC	GND	VDD_NA	GND	VDD	GND	VDD_NB	GND	VDD_EB	GND	IO_EB_B1	IO_EB_A1	IO_EB_B0	IO_EB_A0	F
G	IO_WC_A0	IO_WC_B0	IO_WC_A1	IO_WC_B1	GND	VDD	GND	VDD	GND	VDD	GND	VDD	GND	VDD_EA	IO_EA_B8	IO_EA_A8	IO_EA_B7	IO_EA_A7	G
H	IO_WB_A7	IO_WB_B7	IO_WB_A8	IO_WB_B8	VDD_WB	GND	VDD	GND	VDD	GND	VDD	GND	VDD	GND	IO_EA_B6	IO_EA_A6	VDD_EA	GND	H
J	GND	VDD_WB	IO_WB_A6	IO_WB_B6	GND	VDD	GND	VDD	GND	VDD	GND	VDD	GND	VDD_EA	IO_EA_B5	IO_EA_A5	IO_EA_B4	IO_EA_A4	J
K	IO_WB_A5	IO_WB_B5	IO_WB_A4	IO_WB_B4	VDD_WB	GND	VDD	GND	VDD	GND	VDD	GND	VDD	GND	IO_EA_B3	IO_EA_A3	IO_EA_B2	IO_EA_A2	K
L	IO_WB_A3	IO_WB_B3	IO_WB_A2	IO_WB_B2	GND	VDD	GND	VDD	GND	VDD	GND	VDD	GND	VDD_EA	IO_EA_B1	IO_EA_A1	VDD_EA	GND	L
M	GND	VDD_WB	IO_WB_A1	IO_WB_B1	VDD_WB	GND	VDD	GND	VDD	GND	VDD	GND	VDD	IO_EA_B0	IO_EA_A0	GND	IO_SB_A3	IO_SB_B3	M
N	IO_WB_A0	IO_WB_B0	SPI_CS_N	SPI_CLK	VDD_WA	VDD	GND	VDD	GND	VDD	VDD_SB	GND	VDD_SB	IO_SB_A8	IO_SB_B8	N.C.	GND	VDD_SB	N
P	SPI_D1	SPI_D0	VDD_WA	GND	VDD_WA	VDD_SA	GND	VDD_SA	GND	VDD_SA	IO_SB_A4	IO_SB_A7	IO_SB_B7	IO_SB_A6	IO_SB_B6	VDD_PLL	IO_SB_A2	IO_SB_B2	P
R	SPI_D3	SPI_D2	JTAG_TCK	SPI_FWD	CFG_MD0	IO_SA_A1	IO_SA_A2	IO_SA_A4	IO_SA_A6	IO_SA_A7	IO_SB_B4	GND	IO_SB_A5	IO_SB_B5	VDD_SB	GND	IO_SB_A1	IO_SB_B1	R
T	VDD_WA	JTAG_TDI	JTAG_TMS	GND	CFG_MD1	IO_SA_B1	IO_SA_B2	IO_SA_B4	IO_SA_B6	IO_SA_B7	GND	SER_CLK	SER_CLK_N	VDD_CLK	RST_N	VDD_SER_PLL	GND	VDD_SB	T
U	POR_EN	JTAG_TDO	VDD_WA	CFG_MD2	IO_SA_A0	VDD_SA	IO_SA_A3	IO_SA_A5	VDD_SA	IO_SA_A8	SER_RX_P	VDD_SER	SER_TX_P	GND	GND	GND	IO_SB_A0	IO_SB_B0	U
V	GND	CFG_FAILED_N	CFG_DONE	CFG_MD3	IO_SA_B0	GND	IO_SA_B3	IO_SA_B5	GND	IO_SA_B8	SER_RX_N	SER_RTTERM	SER_TX_N	GND	POR_ADJ	GND	VDD_SER	GND	V

Figure 5.1: CCGM1A1 FBGA pinout

N			IO_WA_A8	IO_WA_B8	
P	IO_WA_A7	IO_WA_B7			
R	IO_WA_A6	IO_WA_B6	IO_WA_A5	IO_WA_B5	IO_WA_A0
T		IO_WA_A4	IO_WA_B4		IO_WA_B0
U	IO_WA_A3	IO_WA_B3		IO_WA_A1	
V		IO_WA_A2	IO_WA_B2	IO_WA_B1	

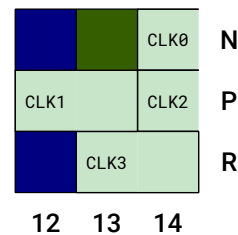

Figure 5.2: Configuration pins of CCGM1A1 FBGA pinout for use as GPIO after configuration

Figure 5.3: Clock input pins as second function of some GPIOs

5.2 CCGM1A1 Pinout Description

All ball signals are grouped as shown in Table 5.1.

Table 5.1: Pin types

Color	Pin type	Number of pins
	<u>North GPIO banks NA and NB</u> Each bank has 18 GPIO signals and both have separate power supply balls and can be driven individually. GPIO signals are grouped by pairs and each pair can get configured to be either two single ended or a differential pair signal.	36
	<u>East GPIO banks EA and EB</u> Each bank has 18 GPIO signals and both have separate power supply balls and can be driven individually. GPIO signals are grouped by pairs and each pair can get configured to be either two single ended or a differential pair signal.	36
	<u>South GPIO banks SA and SB</u> Each bank has 18 GPIO signals and both have separate power supply balls and can be driven individually. GPIO signals are grouped by pairs and each pair can get configured to be either two single ended or a differential pair signal.	36
	<u>Configuration pins or west GPIO bank WA alternatively</u> The configuration interface consists of 18 pins. After configuration procedure, these balls can be configured to be normal GPIO signals. They are grouped by pairs and each pair can get configured to be either two single ended or a differential pair signal.	18
	<u>West GPIO banks WB and WC</u> Each bank has 18 GPIO signals and both have separate power supply balls and can be driven individually. GPIO signals are grouped by pairs and each pair can get configured to be either two single ended or a differential pair signal.	36
	<u>Serializer / Deserializer (SerDes) signal pins</u> The SerDes interface consists of differential transmit and receive signals and a termination input pin. Furthermore, dedicated power supply exists to the SerDes interface and the SerDes phase-locked loop (PLL) function.	5
	<u>Power supply pins for FPGA core and GPIO</u> The CCGM1A1 core gets supplied from a single power source. The GPIO banks have own power supply pins each. Additionally, some further power supply pins are available for SerDes and other functions.	78

(continued on next page)

Table 5.1: Pin types

(continued from previous page)

























Color	Pin type	Number of pins
	<u>Ground pins</u> CCGM1A1 has a single ground level for all supply voltages. All ground pins must be connected.	74
	<u>Any other pins</u> Clock input (single ended or differential)reset input are available in this pin group.	5

Table 5.2: CCGM1A1 Pin list sorted by ball name

Ball	Signal name	Signal group	Reset category	Description
 A1	GND	Ground	0	Gound
 A2	VDD_WC	Power	0	3rd GPIO west bank power supply
 A3	IO_NA_A0	GPIO	1	1st GPIO north bank signal A0
 A4	IO_NA_A1	GPIO	1	1st GPIO north bank signal A1
 A5	VDD_NA	Power	0	1st GPIO north bank power supply
 A6	IO_NA_A4	GPIO	1	1st GPIO north bank signal A4
 A7	GND	Ground	0	Ground
 A8	IO_NA_A7	GPIO	1	1st GPIO north bank signal A7
 A9	IO_NB_B0	GPIO	1	2nd GPIO north bank signal B0
 A10	GND	Ground	0	Ground
 A11	IO_NB_B2	GPIO	1	2nd GPIO north bank signal B2
 A12	IO_NB_B4	GPIO	1	2nd GPIO north bank signal B4
 A13	GND	Ground	0	Ground
 A14	IO_NB_B7	GPIO	1	2nd GPIO north bank signal B7
 A15	IO_EB_B8	GPIO	1	2nd GPIO east bank signal B8
 A16	VDD_EB	Power	0	2nd GPIO east bank power supply
 A17	IO_EB_B5	GPIO	1	2nd GPIO east bank signal B5
 A18	GND	Ground	0	Ground
 B1	IO_WC_A8	GPIO	1	3rd GPIO west bank signal A8
 B2	IO_WC_B8	GPIO	1	3rd GPIO west bank signal B8
 B3	IO_NA_B0	GPIO	1	1st GPIO north bank signal B0
 B4	IO_NA_B1	GPIO	1	1st GPIO north bank signal B1

(continued on next page)

Table 5.2: CCGM1A1 Pin list sorted by ball name

(continued from previous page)

Ball	Signal name	Signal group	Reset category	Description
B5	IO_NA_A2	GPIO	1	1st GPIO north bank signal A2
B6	IO_NA_B4	GPIO	1	1st GPIO north bank signal B4
B7	VDD_NA	Power	0	1st GPIO north bank power supply
B8	IO_NA_B7	GPIO	1	1st GPIO north bank signal B7
B9	IO_NB_A0	GPIO	1	2nd GPIO north bank signal A0
B10	VDD_NB	Power	0	2nd GPIO north bank power supply
B11	IO_NB_A2	GPIO	1	2nd GPIO north bank signal A2
B12	IO_NB_A4	GPIO	1	2nd GPIO north bank signal A4
B13	VDD_NB	Power	0	2nd GPIO north bank power supply
B14	IO_NB_A7	GPIO	1	2nd GPIO north bank signal A7
B15	IO_EB_A8	GPIO	1	2nd GPIO east bank signal A8
B16	GND	Ground	0	Ground
B17	IO_EB_A5	GPIO	1	2nd GPIO east bank signal A5
B18	VDD_EB	Power	0	2nd GPIO east bank power supply
C1	GND	Ground	0	Ground
C2	VDD_WC	Power	0	3rd GPIO west bank power supply
C3	IO_WC_A7	GPIO	1	3rd GPIO west bank signal A7
C4	IO_WC_B7	GPIO	1	3rd GPIO west bank signal B7
C5	IO_NA_B2	GPIO	1	1st GPIO north bank signal B2
C6	IO_NA_A3	GPIO	1	1st GPIO north bank signal A3
C7	IO_NA_A5	GPIO	1	1st GPIO north bank signal A5
C8	IO_NA_A6	GPIO	1	1st GPIO north bank signal A6
C9	IO_NA_A8	GPIO	1	1st GPIO north bank signal A8
C10	IO_NB_B1	GPIO	1	2nd GPIO north bank signal B1
C11	IO_NB_B3	GPIO	1	2nd GPIO north bank signal B3
C12	IO_NB_B5	GPIO	1	2nd GPIO north bank signal B5
C13	IO_NB_B6	GPIO	1	2nd GPIO north bank signal B6
C14	IO_NB_B8	GPIO	1	2nd GPIO north bank signal B8
C15	IO_EB_B7	GPIO	1	2nd GPIO east bank signal B7
C16	IO_EB_B6	GPIO	1	2nd GPIO east bank signal B6
C17	IO_EB_B4	GPIO	1	2nd GPIO east bank signal B4
C18	IO_EB_A4	GPIO	1	2nd GPIO east bank signal A4
D1	IO_WC_A5	GPIO	1	3rd GPIO west bank signal A5
D2	IO_WC_B5	GPIO	1	3rd GPIO west bank signal B5

(continued on next page)

Table 5.2: CCGM1A1 Pin list sorted by ball name

(continued from previous page)

Ball	Signal name	Signal group	Reset category	Description
D3	IO_WC_A6	GPIO	1	3rd GPIO west bank signal A6
D4	IO_WC_B6	GPIO	1	3rd GPIO west bank signal B6
D5	VDD_WC	Power	0	3rd GPIO west bank power supply
D6	IO_NA_B3	GPIO	1	1st GPIO north bank signal B3
D7	IO_NA_B5	GPIO	1	1st GPIO north bank signal B5
D8	IO_NA_B6	GPIO	1	1st GPIO north bank signal B6
D9	IO_NA_B8	GPIO	1	1st GPIO north bank signal B8
D10	IO_NB_A1	GPIO	1	2nd GPIO north bank signal A1
D11	IO_NB_A3	GPIO	1	2nd GPIO north bank signal A3
D12	IO_NB_A5	GPIO	1	2nd GPIO north bank signal A5
D13	IO_NB_A6	GPIO	1	2nd GPIO north bank signal A6
D14	IO_NB_A8	GPIO	1	2nd GPIO north bank signal A8
D15	IO_EB_A7	GPIO	1	2nd GPIO east bank signal A7
D16	IO_EB_A6	GPIO	1	2nd GPIO east bank signal A6
D17	IO_EB_B2	GPIO	1	2nd GPIO east bank signal B2
D18	IO_EB_A2	GPIO	1	2nd GPIO east bank signal A2
E1	IO_WC_A3	GPIO	1	3rd GPIO west bank signal A3
E2	IO_WC_B3	GPIO	1	3rd GPIO west bank signal B3
E3	IO_WC_A4	GPIO	1	3rd GPIO west bank signal A4
E4	IO_WC_B4	GPIO	1	3rd GPIO west bank signal B4
E5	GND	Ground	0	Ground
E6	VDD_NA	Power	0	1st GPIO north bank power supply
E7	GND	Ground	0	Ground
E8	VDD_NA	Power	0	1st GPIO north bank power supply
E9	GND	Ground	0	Ground
E10	VDD_NB	Power	0	2nd GPIO north bank power supply
E11	GND	Ground	0	Ground
E12	VDD_NB	Power	0	2nd GPIO north bank power supply
E13	GND	Ground	0	Ground
E14	VDD_EB	Power	0	2nd GPIO east bank power supply
E15	IO_EB_B3	GPIO	1	2nd GPIO east bank signal B3
E16	IO_EB_A3	GPIO	1	2nd GPIO east bank signal A3
E17	VDD_EB	Power	0	2nd GPIO east bank power supply
E18	GND	Ground	0	Ground

(continued on next page)

Table 5.2: CCGM1A1 Pin list sorted by ball name

(continued from previous page)

Ball	Signal name	Signal group	Reset category	Description
F1	GND	Ground	0	Ground
F2	VDD_WC	Power	0	3rd GPIO west bank power supply
F3	IO_WC_A2	GPIO	1	3rd GPIO west bank signal A2
F4	IO_WC_B2	GPIO	1	3rd GPIO west bank signal B2
F5	VDD_WC	Power	0	3rd GPIO west bank power supply
F6	GND	Ground	0	Ground
F7	VDD_NA	Power	0	1st GPIO north bank power supply
F8	GND	Ground	0	Ground
F9	VDD	Power	0	Core power supply
F10	GND	Ground	0	Ground
F11	VDD_NB	Power	0	2nd GPIO north bank power supply
F12	GND	Ground	0	Ground
F13	VDD_EB	Power	0	2nd GPIO east bank power supply
F14	GND	Ground	0	Ground
F15	IO_EB_B1	GPIO	1	2nd GPIO east bank signal B1
F16	IO_EB_A1	GPIO	1	2nd GPIO east bank signal A1
F17	IO_EB_B0	GPIO	1	2nd GPIO east bank signal B0
F18	IO_EB_A0	GPIO	1	2nd GPIO east bank signal A0
G1	IO_WC_A0	GPIO	1	3rd GPIO west bank signal A0
G2	IO_WC_B0	GPIO	1	3rd GPIO west bank signal B0
G3	IO_WC_A1	GPIO	1	3rd GPIO west bank signal A1
G4	IO_WC_B1	GPIO	1	3rd GPIO west bank signal B1
G5	GND	Ground	0	Ground
G6	VDD	Power	0	Core power supply
G7	GND	Ground	0	Ground
G8	VDD	Power	0	Core power supply
G9	GND	Ground	0	Ground
G10	VDD	Power	0	Core power supply
G11	GND	Ground	0	Ground
G12	VDD	Power	0	Core power supply
G13	GND	Ground	0	Ground
G14	VDD_EA	Power	0	1st GPIO east bank power supply
G15	IO_EA_B8	GPIO	1	1st GPIO east bank signal B8
G16	IO_EA_A8	GPIO	1	1st GPIO east bank signal A8

(continued on next page)

Table 5.2: CCGM1A1 Pin list sorted by ball name

(continued from previous page)

Ball	Signal name	Signal group	Reset category	Description
G17	IO_EA_B7	GPIO	1	1st GPIO east bank signal B7
G18	IO_EA_A7	GPIO	1	1st GPIO east bank signal A7
H1	IO_WB_A7	GPIO	1	2nd GPIO west bank signal A7
H2	IO_WB_B7	GPIO	1	2nd GPIO west bank signal B7
H3	IO_WB_A8	GPIO	1	2nd GPIO west bank signal A8
H4	IO_WB_B8	GPIO	1	2nd GPIO west bank signal B8
H5	VDD_WB	Power	0	2nd GPIO west bank power supply
H6	GND	Ground	0	Ground
H7	VDD	Power	0	Core power supply
H8	GND	Ground	0	Ground
H9	VDD	Power	0	Core power supply
H10	GND	Ground	0	Ground
H11	VDD	Power	0	Core power supply
H12	GND	Ground	0	Ground
H13	VDD	Power	0	Core power supply
H14	GND	Ground	0	Ground
H15	IO_EA_B6	GPIO	1	1st GPIO east bank signal B6
H16	IO_EA_A6	GPIO	1	1st GPIO east bank signal A6
H17	VDD_EA	Power	0	1st GPIO east bank power supply
H18	GND	Ground	0	Ground
J1	GND	Ground	0	Ground
J2	VDD_WB	Power	0	2nd GPIO west bank power supply
J3	IO_WB_A6	GPIO	1	2nd GPIO west bank signal A6
J4	IO_WB_B6	GPIO	1	2nd GPIO west bank signal B6
J5	GND	Ground	0	Ground
J6	VDD	Power	0	Core power supply
J7	GND	Ground	0	Ground
J8	VDD	Power	0	Core power supply
J9	GND	Ground	0	Ground
J10	VDD	Power	0	Core power supply
J11	GND	Ground	0	Ground
J12	VDD	Power	0	Core power supply
J13	GND	Ground	0	Ground
J14	VDD_EA	Power	0	1st GPIO east bank power supply

(continued on next page)

Table 5.2: CCGM1A1 Pin list sorted by ball name

(continued from previous page)

Ball	Signal name	Signal group	Reset category	Description
J15	IO_EA_B5	GPIO	1	1st GPIO east bank signal B5
J16	IO_EA_A5	GPIO	1	1st GPIO east bank signal A5
J17	IO_EA_B4	GPIO	1	1st GPIO east bank signal B4
J18	IO_EA_A4	GPIO	1	1st GPIO east bank signal A4
K1	IO_WB_A5	GPIO	1	2nd GPIO west bank signal A5
K2	IO_WB_B5	GPIO	1	2nd GPIO west bank signal B5
K3	IO_WB_A4	GPIO	1	2nd GPIO west bank signal A4
K4	IO_WB_B4	GPIO	1	2nd GPIO west bank signal B4
K5	VDD_WB	Power	0	2nd GPIO west bank power supply
K6	GND	Ground	0	Ground
K7	VDD	Power	0	Core power supply
K8	GND	Ground	0	Ground
K9	VDD	Power	0	Core power supply
K10	GND	Ground	0	Ground
K11	VDD	Power	0	Core power supply
K12	GND	Ground	0	Ground
K13	VDD	Power	0	Core power supply
K14	GND	Ground	0	Ground
K15	IO_EA_B3	GPIO	1	1st GPIO east bank signal B3
K16	IO_EA_A3	GPIO	1	1st GPIO east bank signal A3
K17	IO_EA_B2	GPIO	1	1st GPIO east bank signal B2
K18	IO_EA_A2	GPIO	1	1st GPIO east bank signal A2
L1	IO_WB_A3	GPIO	1	2nd GPIO west bank signal A3
L2	IO_WB_B3	GPIO	1	2nd GPIO west bank signal B3
L3	IO_WB_A2	GPIO	1	2nd GPIO west bank signal A2
L4	IO_WB_B2	GPIO	1	2nd GPIO west bank signal B2
L5	GND	Ground	0	Ground
L6	VDD	Power	0	Core power supply
L7	GND	Ground	0	Ground
L8	VDD	Power	0	Core power supply
L9	GND	Ground	0	Ground
L10	VDD	Power	0	Core power supply
L11	GND	Ground	0	Ground
L12	VDD	Power	0	Core power supply

(continued on next page)

Table 5.2: CCGM1A1 Pin list sorted by ball name

(continued from previous page)

Ball	Signal name	Signal group	Reset category	Description
L13	GND	Ground	0	Ground
L14	VDD_EA	Power	0	1st GPIO east bank power supply
L15	IO_EA_B1	GPIO	1	1st GPIO east bank signal B1
L16	IO_EA_A1	GPIO	1	1st GPIO east bank signal A1
L17	VDD_EA	Power	0	1st GPIO east bank power supply
L18	GND	Ground	0	Ground
M1	GND	Ground	0	Ground
M2	VDD_WB	Power	0	2nd GPIO west bank power supply
M3	IO_WB_A1	GPIO	1	2nd GPIO west bank signal A1
M4	IO_WB_B1	GPIO	1	2nd GPIO west bank signal B1
M5	VDD_WB	Power	0	2nd GPIO west bank power supply
M6	GND	Ground	0	Ground
M7	VDD	Power	0	Core power supply
M8	GND	Ground	0	Ground
M9	VDD	Power	0	Core power supply
M10	GND	Ground	0	Ground
M11	VDD	Power	0	Core power supply
M12	GND	Ground	0	Ground
M13	VDD	Power	0	Core power supply
M14	IO_EA_B0	GPIO	1	1st GPIO east bank signal B0
M15	IO_EA_A0	GPIO	1	1st GPIO east bank signal A0
M16	GND	Ground	0	Ground
M17	IO_SB_A3	GPIO	1	2nd GPIO south bank signal A3
M18	IO_SB_B3	GPIO	1	2nd GPIO south bank signal B3
N1	IO_WB_A0	GPIO	1	2nd GPIO west bank signal A0
N2	IO_WB_B0	GPIO	1	2nd GPIO west bank signal B0
N3	SPI_CS_N	GPIO	3	1 st function: Configuration SPI chip select
	IO_WA_A8	GPIO	1	2 nd function: 1st GPIO west bank signal A8
N4	SPI_CLK	GPIO	3	1 st function: Configuration SPI clock
	IO_WA_B8	GPIO	1	2 nd function: 1st GPIO west bank signal B8
N5	VDD_WA	Power	0	1st GPIO west bank power supply
N6	VDD	Power	0	Core power supply
N7	GND	Ground	0	Ground
N8	VDD	Power	0	Core power supply

(continued on next page)

Table 5.2: CCGM1A1 Pin list sorted by ball name

(continued from previous page)

Ball	Signal name	Signal group	Reset category	Description
N9	GND	Ground	0	Ground
N10	VDD	Power	0	Core power supply
N11	VDD_SB	Power	0	2nd GPIO south bank power supply
N12	GND	Ground	0	Ground
N13	VDD_SB	Power	0	2nd GPIO south bank power supply
N14	IO_SB_A8 CLK0	GPIO	1	1 st function: 2nd GPIO south bank signal A8
		GPIO	1	2 nd function: 1st clock input
N15	IO_SB_B8	GPIO	1	2nd GPIO south bank signal B8
N16	N.C.	Other	0	Not connected. This pin must be left open.
N17	GND	Ground	0	Ground
N18	VDD_SB	Power	0	2nd GPIO south bank power supply
P1	SPI_D1 IO_WA_A7	GPIO	4	1 st function: Configuration SPI data bit 1
		GPIO	1	2 nd function: 1st GPIO west bank signal A7
P2	SPI_D0 IO_WA_B7	GPIO	3	1 st function: Configuration SPI data bit 0
		GPIO	1	2 nd function: 1st GPIO west bank signal B7
P3	VDD_WA	Power	0	1st GPIO west bank power supply
P4	GND	Ground	0	Ground
P5	VDD_WA	Power	0	1st GPIO west bank power supply
P6	VDD_SA	Power	0	1st GPIO south bank power supply
P7	GND	Ground	0	Ground
P8	VDD_SA	Power	0	1st GPIO south bank power supply
P9	GND	Ground	0	Ground
P10	VDD_SA	Power	0	1st GPIO south bank power supply
P11	IO_SB_A4	GPIO	1	2nd GPIO south bank signal A4
P12	IO_SB_A7 CLK1	GPIO	1	1 st function: 2nd GPIO south bank signal A7
		GPIO	1	2 nd function: 2nd clock input
P13	IO_SB_B7	GPIO	1	2nd GPIO south bank signal B7
P14	IO_SB_A6 CLK2	GPIO	1	1 st function: 2nd GPIO south bank signal A6
		GPIO	1	2 nd function: 3rd clock input
P15	IO_SB_B6	GPIO	1	2nd GPIO south bank signal B6
P16	VDD_PLL	Power	0	PLL power supply
P17	IO_SB_A2	GPIO	1	2nd GPIO south bank signal A2
P18	IO_SB_B2	GPIO	1	2nd GPIO south bank signal B2
R1	SPI_D3 IO_WA_A6	GPIO	4	1 st function: Configuration SPI data bit 3
		GPIO	1	2 nd function: 1st GPIO west bank signal A6

(continued on next page)

Table 5.2: CCGM1A1 Pin list sorted by ball name

(continued from previous page)

Ball	Signal name	Signal group	Reset category	Description
R2	SPI_D2	GPIO	4	1 st function: Configuration SPI data bit 2
	IO_WA_B6	GPIO	1	2 nd function: 1st GPIO west bank signal B6
R3	JTAG_TCK	GPIO	4	1 st function: Configuration JTAG clock
	IO_WA_A5	GPIO	1	2 nd function: 1st GPIO west bank signal A5
R4	SPI_FWD	GPIO	2	1 st function: Configuration SPI data forward
	IO_WA_B5	GPIO	1	2 nd function: 1st GPIO west bank signal B5
R5	CFG_MD0	GPIO	4	1 st function: Configuration mode bit 0
	IO_WA_A0	GPIO	1	2 nd function: 1st GPIO west bank signal A0
R6	IO_SA_A1	GPIO	1	1st GPIO south bank signal A1
R7	IO_SA_A2	GPIO	1	1st GPIO south bank signal A2
R8	IO_SA_A4	GPIO	1	1st GPIO south bank signal A4
R9	IO_SA_A6	GPIO	1	1st GPIO south bank signal A6
R10	IO_SA_A7	GPIO	1	1st GPIO south bank signal A7
R11	IO_SB_B4	GPIO	1	2nd GPIO south bank signal B4
R12	GND	Ground	0	Ground
R13	IO_SB_A5	GPIO	1	1 st function: 2nd GPIO south bank signal A5
	CLK3	GPIO	1	2 nd function: 4th clock input
R14	IO_SB_B5	GPIO	1	2nd GPIO south bank signal B5
R15	VDD_SB	Power	0	2nd GPIO south bank power supply
R16	GND	Ground	0	Ground
R17	IO_SB_A1	GPIO	1	2nd GPIO south bank signal A1
R18	IO_SB_B1	GPIO	1	2nd GPIO south bank signal B1
T1	VDD_WA	Power	0	1st GPIO west bank power supply
T2	JTAG_TDI	GPIO	4	1 st function: JTAG data input
	IO_WA_A4	GPIO	1	2 nd function: 1st GPIO west bank signal A4
T3	JTAG_TMS	GPIO	4	1 st function: JTAG test mode select
	IO_WA_B4	GPIO	1	2 nd function: 1st GPIO west bank signal B4
T4	GND	Ground	0	Ground
T5	CFG_MD1	GPIO	4	1 st function: Configuration mode bit 1
	IO_WA_B0	GPIO	1	2 nd function: 1st GPIO west bank signal B0
T6	IO_SA_B1	GPIO	1	1st GPIO south bank signal B1
T7	IO_SA_B2	GPIO	1	1st GPIO south bank signal B2
T8	IO_SA_B4	GPIO	1	1st GPIO south bank signal B4
T9	IO_SA_B6	GPIO	1	1st GPIO south bank signal B6
T10	IO_SA_B7	GPIO	1	1st GPIO south bank signal B7
T11	GND	Ground	0	Ground

(continued on next page)

Table 5.2: CCGM1A1 Pin list sorted by ball name

(continued from previous page)

Ball	Signal name	Signal group	Reset category	Description
T12	SER_CLK	Other	4	SerDes clock, positive LVDS signal (or single ended)
T13	SER_CLK_N	Other	1	SerDes clock, negative LVDS signal
T14	VDD_CLK	Power	0	Clock signal power supply
T15	RST_N	Other	4	Reset
T16	VDD_SER_PLL	Power	0	SerDes PLL power supply (1.0V to 1.1V \pm 50 mV)
T17	GND	Ground	0	Ground
T18	VDD_SB	Power	0	2nd GPIO south bank power supply
U1	POR_EN	GPIO	2	1 st function: Enable power-on reset
	IO_WA_A3	GPIO	1	2 nd function: 1st GPIO west bank signal A3
U2	JTAG_TDO	GPIO	2	1 st function: JTAG data output
	IO_WA_B3	GPIO	1	2 nd function: 1st GPIO west bank signal B3
U3	VDD_WA	Power	0	1st GPIO west bank power supply
U4	CFG_MD2	GPIO	4	1 st function: Configuration mode bit 2
	IO_WA_A1	GPIO	1	2 nd function: 1st GPIO west bank signal A1
U5	IO_SA_A0	GPIO	1	1st GPIO south bank signal A0
U6	VDD_SA	Power	0	1st GPIO south bank power supply
U7	IO_SA_A3	GPIO	1	1st GPIO south bank signal A3
U8	IO_SA_A5	GPIO	1	1st GPIO south bank signal A5
U9	VDD_SA	Power	0	1st GPIO south bank power supply
U10	IO_SA_A8	GPIO	1	1st GPIO south bank signal A8
U11	SER_RX_P	SerDes	1	Receive data line, positive LVDS signal
U12	VDD_SER	Power	0	SerDes core power supply (1.0V to 1.1V \pm 50 mV)
U13	SER_TX_P	SerDes	1	Transmit data line, positive LVDS signal
U14	GND	Ground	0	Ground
U15	GND	Ground	0	Ground
U16	GND	Ground	0	Ground
U17	IO_SB_A0	GPIO	1	2nd GPIO south bank signal A0
U18	IO_SB_B0	GPIO	1	2nd GPIO south bank signal B0
V1	GND	Ground	0	Ground
V2	CFG_FAILED_N	GPIO	2	1 st function: Configuration failed signal
	IO_WA_A2	GPIO	1	2 nd function: 1st GPIO west bank signal A2
V3	CFG_DONE	GPIO	2	1 st function: Configuration done signal
	IO_WA_B2	GPIO	1	2 nd function: 1st GPIO west bank signal B2

(continued on next page)

Table 5.2: CCGM1A1 Pin list sorted by ball name

(continued from previous page)

Ball	Signal name	Signal group	Reset category	Description
V4	CFG_MD3	GPIO	4	1 st function: Configuration mode bit 3
	IO_WA_B1	GPIO	1	2 nd function: 1st GPIO west bank signal B1
V5	IO_SA_B0	GPIO	1	1st GPIO south bank signal B0
V6	GND	Ground	0	Ground
V7	IO_SA_B3	GPIO	1	1st GPIO south bank signal B3
V8	IO_SA_B5	GPIO	1	1st GPIO south bank signal B5
V9	GND	Ground	0	Ground
V10	IO_SA_B8	GPIO	1	1st GPIO south bank signal B8
V11	SER_RX_N	SerDes	1	Receive data line, negative LVDS signal
V12	SER_RTERM	SerDes	0	Line termination
V13	SER_TX_N	SerDes	1	Transmit data line, negative LVDS signal
V14	GND	Ground	0	Ground
V15	POR_ADJ	Other	0	Power-on-Reset level adjustment
V16	GND	Ground	0	Ground
V17	VDD_SER	Power	0	SerDes core power supply (1.0V to 1.1V ±50 mV)
V18	GND	Ground	0	Ground

Reset categories:

- 0: No reset (supply or analog input pin)
- 1: Pin disabled, high-z
- 2: Pin characteristic already during reset state
- 3: Pin characteristic depends on the configuration mode (SPI master: I/O, else: input)
- 4: Input pin

Chapter 6

Mechanical Dimensions

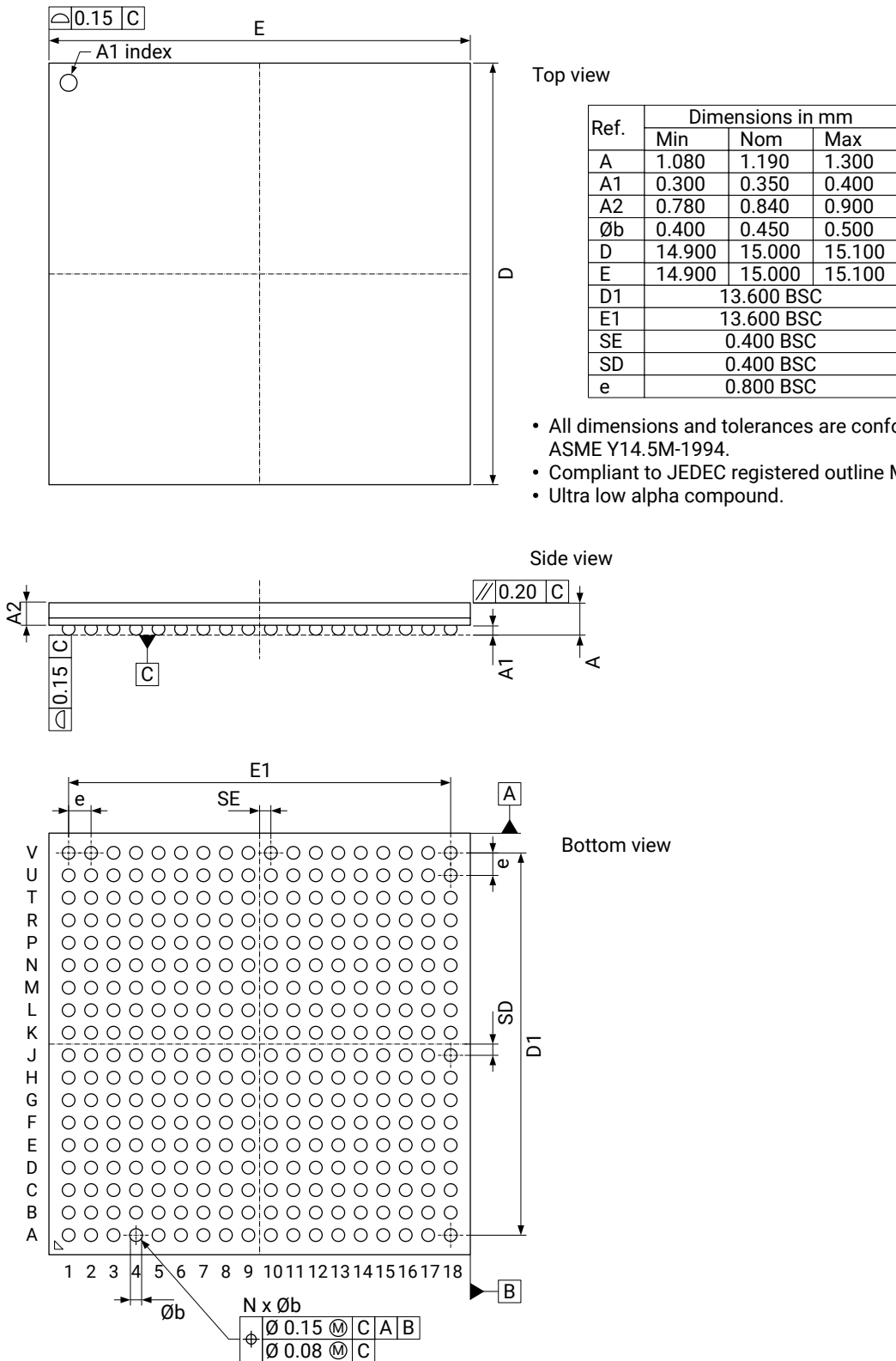

Figure 6.1: FATC FBGA 324 balls package dimensions

Chapter 7

Soldering Guidelines

The recommended profile for soldering reflow of CCGM1A1 for Pb-free assembly correspond to the commonly applied JEDEC Standard JSTD-020E. Table 7.1 and Figure 7.1 illustrate the soldering reflow.

CCGM1A1 may have a crack when thermal stress is applied during assembly if it has absorbed atmospheric moisture. It is recommended that the chip is handled under specific conditions described as follows:

Storage Condition after unpacking (as maximum): Within 168 hours, 30 °C / 60 % RH (MSL 3)

Rebake Condition (as minimum): 125 °C for 24 hours

Table 7.1: Pb-free reflow soldering profile

Symbol	Description	Parameter value
<u>Preheat:</u>		
$T_{S\text{MIN}}$	Minimum temperature	150 °C
$T_{S\text{MAX}}$	Maximum temperature	200 °C
t_s	Time between $T_{S\text{MIN}}$ and $T_{S\text{MAX}}$	60 .. 180 s
<u>Ramp-up:</u>		
T_L	Liquidous temperature	217 °C
	Ramp-up rate $T_{S\text{MAX}}$ to T_L	max 3 °C/s
t_L	Time maintained above T_L	60 .. 150 s
T_P	Peak temperature	260 + 0 / - 5 °C
	Time from 25 °C to peak temperature	max 8 min
t_p	Time within 5 °C of peak temperature	20 .. 40 s
<u>Ramp-down:</u>		
	Ramp-down rate	max 6 °C/s

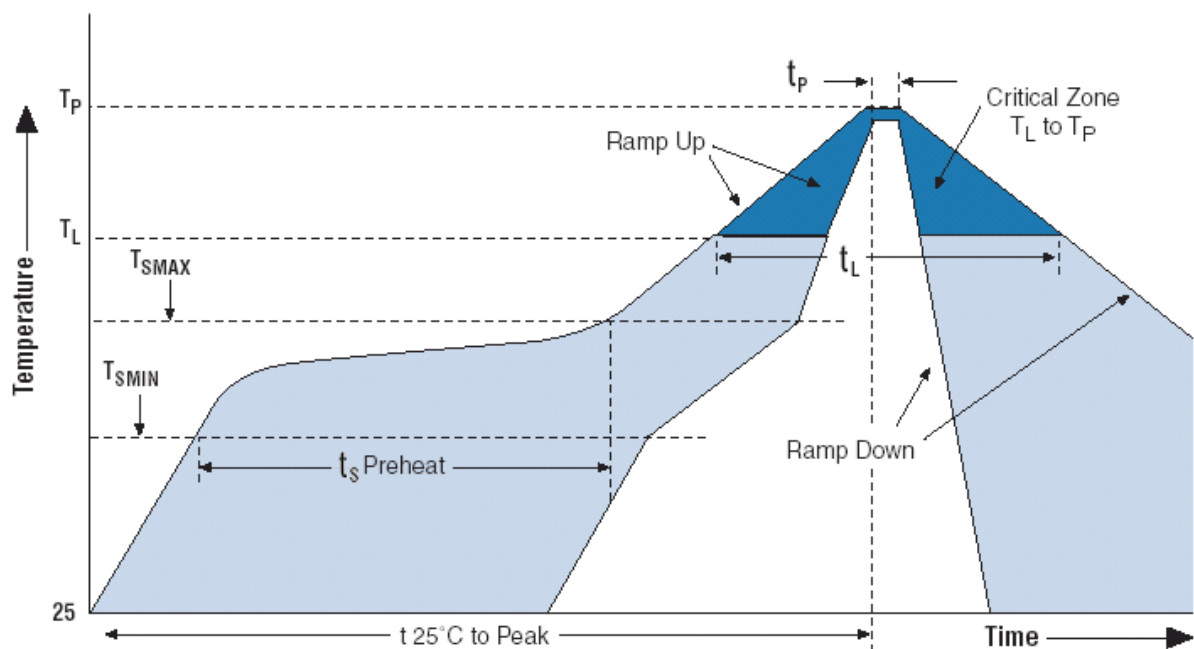
Figure 7.1: Reflow soldering profile

Acronyms

ADPLL	all-digital phase-locked loop	54
AI	artificial intelligence	25
BES	Bottom Edge Select	12, 16, 61, 65, 66, 69, 71
BSDL	Boundary Scan Description Language	102
CP-line	carry & propagation signal line	12, 19, 31, 61, 65–67, 81
CPE	Cologne Programmable Element	12, 15, 16, 19, 23, 29–31, 35–37, 41, 55, 58, 61, 65–67, 69, 71, 73, 75, 81, 82
DCO	digitally controlled oscillator	54, 107
DDR	double data rate	26
DPSRAM	dual port SRAM	15, 23, 29, 30, 35, 38, 40, 42, 46
ECC	error checking and correcting	26, 36–38, 43, 44
EMI	electromagnetic interference	65
ESD	electrostatic discharge	105
FBGA	fine pitch Ball Grid Array	17, 22, 27, 109, 110, 123
FIFO	first-in, first-out memory	15, 16, 19, 26, 36–38, 45–53
FPGA	field-programmable gate array	25, 32, 77, 111

FSM	finite-state machine	16, 96, 99
GLB signal	Global Mesh signals GLB[3:0]	58, 60, 61
GPIO	general purpose input / output	15, 17, 20, 23, 26, 29, 32, 33, 54, 55, 75, 76, 82, 83, 105, 109–111
HBM	Human Body Model	105
HDL	Hardware Description Language	60, 77
IM	Input Multiplexer	23, 74, 75
IoT	Internet of Things	25
IPCEI	Important Project of Common European Interest	25
JSON	JavaScript Object Notation (data interchange format)	80
JTAG	Joint Test Action Group	16, 22, 27, 29, 77, 84, 90, 95–99, 101, 102
LES	Left Edge Select	12, 16, 61, 65, 66, 73
LSB	least significant bit	96, 99
LUT	lookup table	79
LUT-2	2-input lookup table	30
LUT-tree	tree-structure lookup table	26, 79
LVC MOS	low voltage CMOS	33
LVDS	low-voltage differential signaling	15, 20, 26, 32, 33, 83, 105
MUX-4	4-input multiplexer	30
OM	Output Multiplexer	23, 74, 75
PCB	printed circuit board	25, 27, 109
PLL	phase-locked loop	12, 16, 19, 20, 23, 26, 29, 54, 55, 58, 76, 93, 105, 107, 111
POR	power-on reset	16, 86–88

RAM	random-access memory	15, 22, 35–45, 79
ROM	read-only memory	36, 45
RTL	Register Transfer Level	77
SB	Switch Box	16, 23, 29, 37, 61, 74, 75, 82
SB_BIG	Big Switch Box	61, 65
SDF	Standard Delay Format	77, 81
SDP	simple dual port	15, 19, 26, 35, 36, 38, 40–42, 44–48
SerDes	Serializer / Deserializer	23, 26, 29, 54, 76, 105, 111
SLP	Super Low Power	25
SPI	Serial Peripheral Interface	16, 27, 29, 77, 82, 84, 85, 90, 92, 93, 95, 98–102
SRAM	static random-access memory	26, 30, 36, 42, 47
STA	static timing analysis	77
TAP	Test Access Point	95–97, 99
TCK	Test Clock	95, 96
TDI	Test Data Input	95–97
TDO	Test Data Output	95–97
TDP	true dual port	15, 19, 26, 35, 36, 38–48
TMS	Test Mode Select	95, 96
VHDL	Very High Speed Integrated Circuit Hardware Description Language	77
Yosys	Yosys Open SYnthesis Suite	22, 77, 79, 80

GateMate™ FPGA Datasheet
CCGM1A1
DS1001
January 2023

