



**austriamicrosystems AG**

**is now**

**ams AG**

The technical content of this austriamicrosystems datasheet is still valid.

**Contact information:**

**Headquarters:**

ams AG

Tobelbaderstrasse 30

8141 Unterpremstaetten, Austria

Tel: +43 (0) 3136 500 0

e-Mail: [ams\\_sales@ams.com](mailto:ams_sales@ams.com)

Please visit our website at [www.ams.com](http://www.ams.com)

# AS3604

Data Sheet

## Multi-Standard Power Management Unit

### 1 General Description

The AS3604 is a highly-integrated CMOS power management device designed specifically for portable devices such as mobile phones, PDAs, CD players, digital cameras and other devices powered by 1-cell lithium-based or 3- to 4-cell nickel-based batteries. It can be used for any mobile phone handset standards such as CDMA, WCDMA, GSM, GPRS, EDGE, UTMS and other Japanese or American standards.

The device incorporates low dropout regulators (LDOs), DC/DC converters, a complete battery charger, and an audio power amplifier onto one die.

The linear analog LDOs feature extremely high performance regarding:

- Noise – typ  $30\mu\text{V}_{\text{RMS}}$  from 100Hz to 100kHz
- Line/Load Regulation –  $< 1\text{mV}$  static,  $< 10\text{mV}$  transient
- Power Supply Rejection –  $> 70\text{dB}$  @ 1kHz

The integrated Step Down DC/DC Converter does not require an external Schottky diode yet provides very high efficiency (up to 95%) throughout the whole operating range. It can be either used as a stand-alone device or as a pre-regulator for LDOs to increase overall device efficiency.

A Step Up DC/DC Converter is included to supply power for white LEDs, together with programmable current sources to control LED brightness.

A low-distortion audio power amplifier (1 Watt @  $8\Omega$ ) supports handsfree operation and HiFi ring-tones.

The device also features a chemistry-independent battery charger including automatic trickle charging, gas gauge, and programmable constant voltage and current charging.

The AS3604 is controlled via a serial interface and integrates all necessary system specific functions such as Reset, Watchdog, and Power-On Detection.

Output voltages and start-up timings can be programmed on metal-mask level, by register or by an external resistor.

### 2 Key Features

- Ten Programmable High Performance LDOs
  - Two Digital Low-Power LDOs (0.75 to 2.5V, 200mA; 250mA up to 1.4V)
  - Three RF Low-Noise LDOs (1.85 to 3.4V, 200mA)
  - Two RF Low-Noise LDOs (1.85 to 3.4V, 150mA; 200mA up to 2.6V)
  - One SIM Low-Power LDO (1.8 to 3.0V, 20mA)
  - One Periphery Low-Noise LDO (2.5 to 3.2V, 200mA)
  - One Low-Power LDO (2.5V, 10mA)

- Programmable High Efficiency DC/DC Converters
  - Step Down: 0.8 to 3.4V, up to 500mA with 2.2MHz Operating Frequency and Small External Coil (2.2 $\mu\text{H}$ )
  - Step Up: 15V, 45mA, (for White LEDs)
- Stereo Audio Power Amplifier
  - 0.5W @  $4\Omega$  – Stereo; 1W @  $8\Omega$  – Bridged
  - Digital Volume Control, 3dB Steps
  - Click- and Pop-Less Start-Up and Power-Down
- Complete Chemistry-Independent Battery Charger
  - Integrated Gas Gauge
  - Automatic Trickle Charging
  - Programmable Constant Current Charging
  - Programmable Constant Voltage Charging
  - Pulse Charging
  - Safety Functions (Low Battery Shutdown)
  - Over- and Under-Temperature Charge Disable
  - Operation without Battery
  - Can Regulate the Current Through the Battery or from the Charger
  - Charger Input Overvoltage Protection (6V)
  - Shutdown even with Connected Charger
  - Charger Resume Operation
  - Charger Interrupts (Inserted, Removed, Overvoltage, Resume)
  - No-Battery Detection
- Momentary Power Loss Detection
  - Battery Supply Short-Interruption Detection ( $< 200\text{ms}$ ); (e.g., due to a dropped phone)
- Four Programmable Current Sources
  - 8-Bit (0.625 to 160mA)
  - Buzzer
  - Vibrator
  - LEDs
- Wide Battery Supply Range 3.0 to 5.5V
- Four General Purpose Switches ( $1\Omega$  and  $2\Omega$ )
- Three Programmable General Purpose I/O Pins
- On-Chip Bandgap Tuning for High Accuracy ( $\pm 1\%$ )
- Integrated Programmable Watchdog (7.5 to 1900ms)
- Programmable Reset (10 to 110ms)
- Shutdown Current typ  $7\mu\text{A}$  (2.5V Always On)
- Overcurrent and Thermal Protection
- 0.35 $\mu\text{m}$  CMOS Solution
- 2.1 Watt Power Dissipation @ SCSB = 70°C
- 48-pin, 6x6mm QFN Package (0.4mm pitch)

### 3 Applications

Multi-standard power management for mobile phones, PDAs, and any other 1-cell Li+ or 3- to 4-cell NiMh powered devices.

## 4 Block Diagrams

Figure 1. AS3604 Block Diagram. Option: Audio Amplifier In Differential Mode, Step Down DC/DC Converter as Pre-Regulator for Digital LDOs

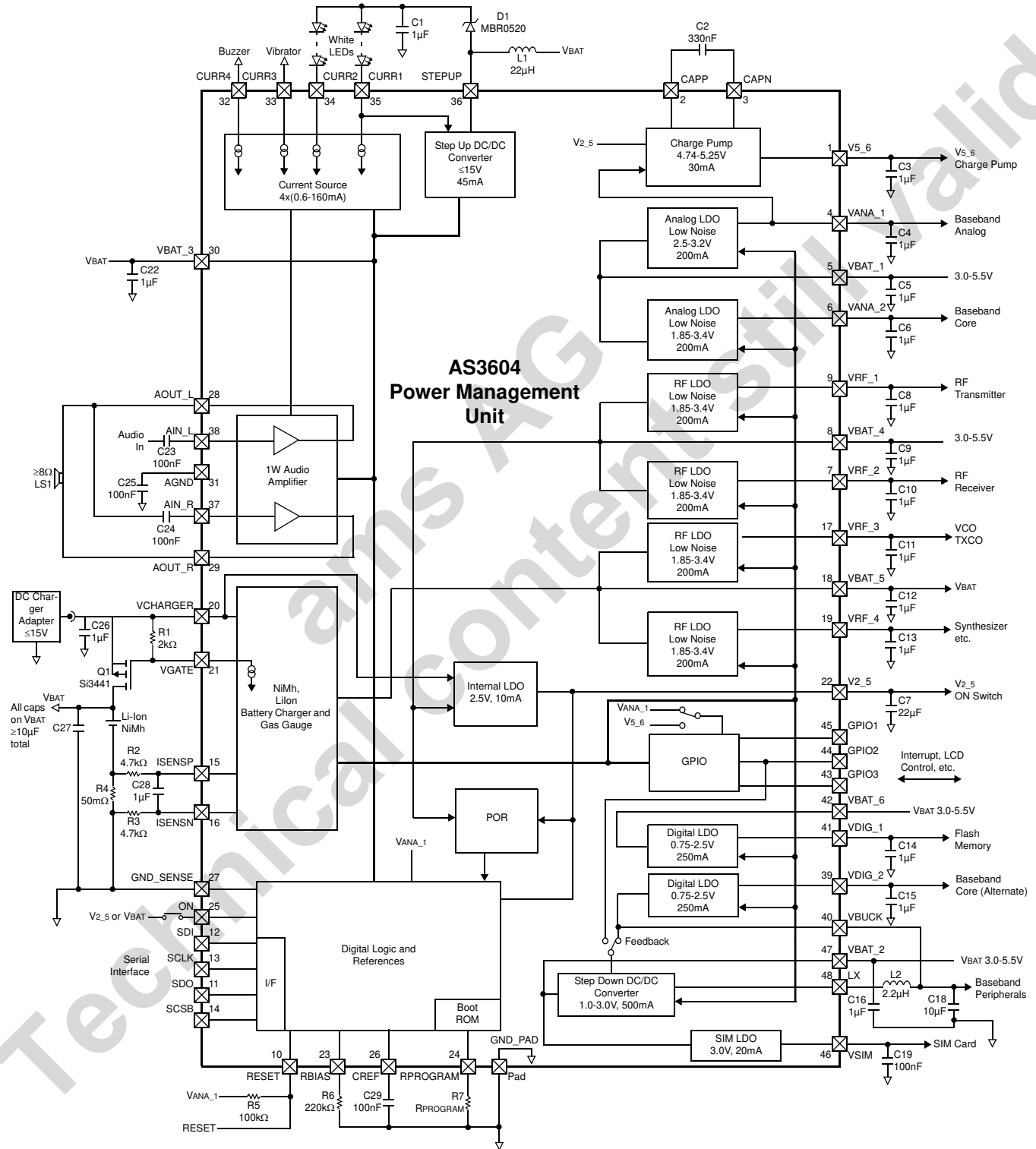

**Note:** Refer to Table 38 on page 74 for specifications of external components.

Figure 2. AS3604 Block Diagram. Option: Audio Amplifier in Stereo Single-Ended Mode, Digital LDOs Separated from Step Down DC/DC Converter

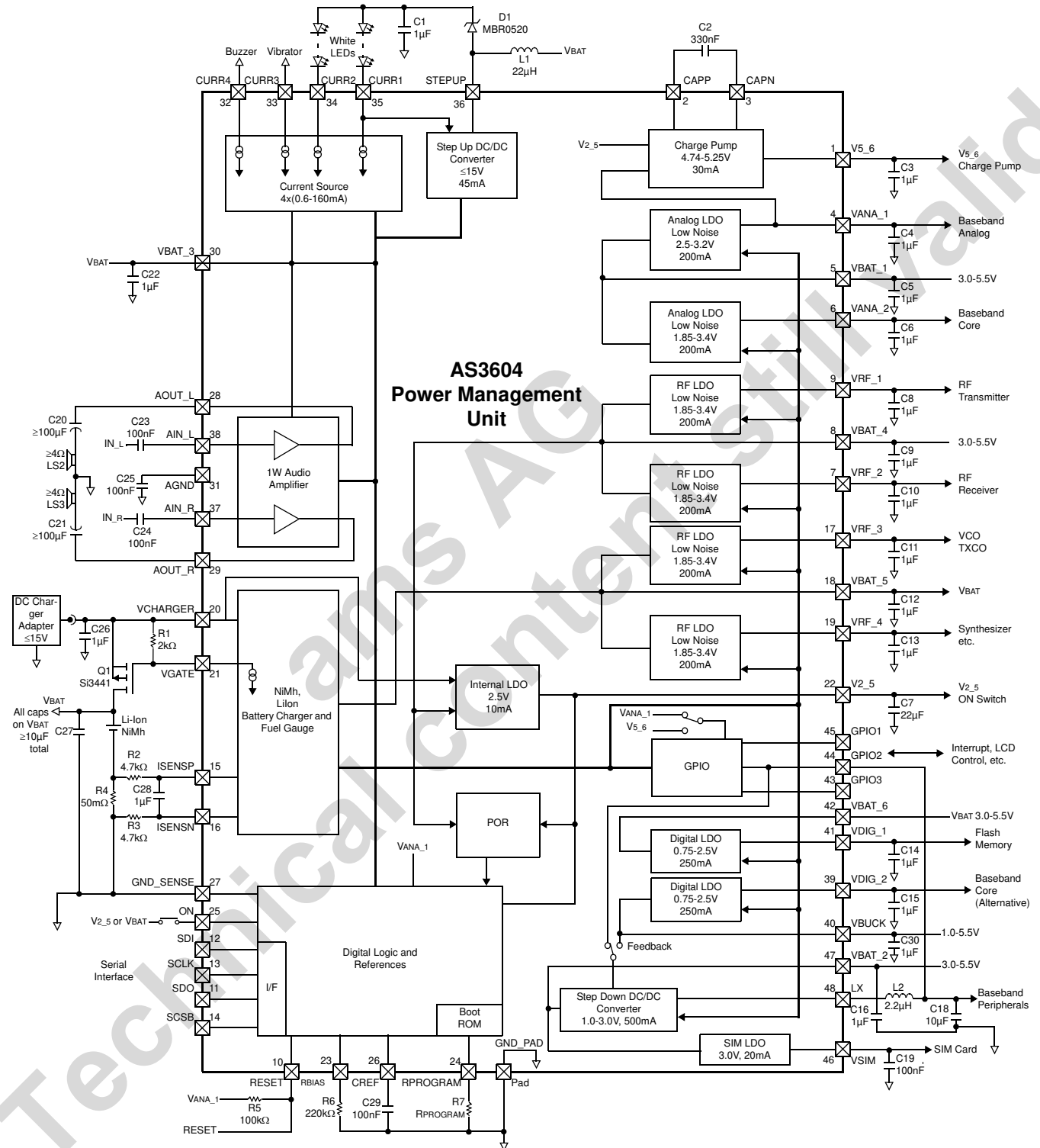

**Note:** Refer to Table 38 on page 74 for specifications of external components.

## Content

1	General Description	1
2	Key Features	1
3	Applications	1
4	Block Diagrams	2
5	Absolute Maximum Ratings (Non-Operating)	6
5.1	Operating Conditions	6
6	Detailed Functional Descriptions	7
6.1	Battery Charger Controller	7
6.2	Step Down DC/DC Converter	24
6.3	Low Dropout Regulators	30
6.4	Charge Pump	41
6.5	Step Up DC/DC Converter	42
6.6	General Purpose Input/Output	44
6.7	Current Sinks	50
6.8	Audio Amplifier	53
7	System Supervisory Functions	56
7.1	Reset	56
7.2	Startup	58
7.3	Protection Functions	59
7.4	Watchdog Block	60
7.5	Internal Reference Circuits	61
7.6	Low Power Mode	63
7.7	Boot Sequence Detection	63
7.8	Serial Interface	64
8	Register Map	68
9	Pinout and Packaging	70
9.1	Pin Descriptions	70
9.2	Package Drawings and Markings	72
10	External Parts List	74
11	Ordering Information	75

## Revision History

Revision	Date	Owner	Description
1.0	23 June 2006	ptr	- Initial release.
1.1	3 March 2007	ptr	- Updated ambient temperature range.
1.11	4 Dec 2008	pkm	- Updated internal LDO supply description
1.2	8 Apr 2009	pkm	- Updated ordering info for AS3604B chip version
1.21	15 Mai 2009	pkm	- Updated abs. max ratings and stand-by current, deleted errata
1.22	21 Aug 2009	pkm	- Updated operating current, SNR and VCHOV

## 5 Absolute Maximum Ratings (Non-Operating)

Stresses beyond the absolute maximum ratings may cause permanent damage to the AS3604. These are stress ratings only. Functional operation of the device at these or beyond those in Operating Conditions is not implied.

**Caution:** Exposure to absolute maximum rating conditions may affect device reliability.

Table 1. Absolute Maximum Ratings

Symbol	Parameter	Min	Max	Unit	Notes
V <sub>IN_HV</sub>	High Voltage Pins	-0.3	18.0	V	Applicable for high voltage pins: VCHARGER, VGATE, and STEPUP
V <sub>IN_MV</sub>	5V Pins	-0.3	7.0	V	Applicable for pins 5V pins: VBAT_1 - VBAT_6, V5_6, VBUCK, GPIO1 - GPIO3, CURR1 - CURR4, AIN_L, AIN_R, AOUT_L, AOUT_R, VRF_1 - VRF_4 (when not in LDO-mode), ON, and LX
V <sub>IN_LV</sub>	3.3V Pins	-0.3	5.0	V	Applicable for 3.3V pins: RESET, SCSB, SCLK, SDI, SDO, VANA_1, VANA_2, VSIM, VDIG_1, VDIG_2, CAPN, AGND, ISENSP, ISENSN, V2_5, CREF, RBIAS, and RPROGRAM
I <sub>IN</sub>	Input Pin Current	-25	+25	mA	At 25°C Norm: JEDEC 17
T <sub>strg</sub>	Storage Temperature Range	-55	125	°C	
	Humidity	5	85	%	Non-condensing
V <sub>ESD</sub>	Electrostatic Discharge	-1000	1000	V	Norm: MIL 883 E Method 3015; ±1000V.
P <sub>T</sub>	Total Power Dissipation		2.1	W	T <sub>AMB</sub> = 70°C
T <sub>max</sub>	Peak Reflow Soldering Temperature		260	°C	T = 20 to 40s, according to the IPC/JEDEC J-STD 020C.

### 5.1 Operating Conditions

Table 2. Operating Conditions

Symbol	Parameter	Min	Typ	Max	Unit	Notes
V <sub>HV</sub>	High Voltage	0.0		15.0	V	Pins VCHARGER, VGATE and STEPUP
V <sub>BAT</sub>	Battery Voltage	3.0	3.6	5.5	V	For pins VBAT_1 - VBAT_6. During startup from ext. battery charger adapter, the battery voltage can be below 3.0V.
V <sub>ANA_1</sub>	Periphery Supply Voltage (for RESET and SPI pins)	2.5	Boot ROM	3.2	V	Internally generated from VANA_1.
V <sub>ON</sub>	Activation voltage for ON pin	1.75	V <sub>2_5</sub>	V <sub>BAT</sub>	V	
V <sub>2_5</sub>	Voltage on Pin V2_5	2.4	2.5	2.6	V	Internally generated.
V <sub>5_6</sub>	Output Voltage of Charge Pump	5.0	5.2	5.6	V	2 x VANA_1
T <sub>AMB</sub>	Ambient Temperature	-40	25	85	°C	
I <sub>BAT</sub>	Operating Current		195	260	µA	Normal operating current. With bit <b>low_power_on</b> (page 62) = 0; only VANA_1 active, no additional external loads.
I <sub>LOWPOWER</sub>	Low-Power Mode Current Consumption		110		µA	With bit <b>low_power_on</b> (page 62) = 1; only VANA_1 active, no additional external loads.
I <sub>POWEROFF</sub>	Power-Off Mode Current Consumption		13	20	µA	With bit <b>power_off</b> (page 57) = 1; only V2_5 is active in power off mode. not tested, guaranteed by design

## 6 Detailed Functional Descriptions

### 6.1 Battery Charger Controller

The AS3604 can serve as a standalone Battery Charger Controller supporting rechargeable lithium-ion (Li+), lithium-polymer (LiPo) and 3- or 4-cell nickel metal-hydride (NiMH) batteries.

The main features of the Battery Charger Controller are:

- Constant Voltage Charge Mode – Described on page 9
- Pulse Charge Mode – Described on page 11
- Battery Presence Detection – Described on page 14
- Operation Without Battery – Described on page 14
- Charge Controller Bypass – Described on page 14
- Overvoltage and Undervoltage Supervision – Described on page 15

Figure 3. Battery Charger Controller Block Diagram

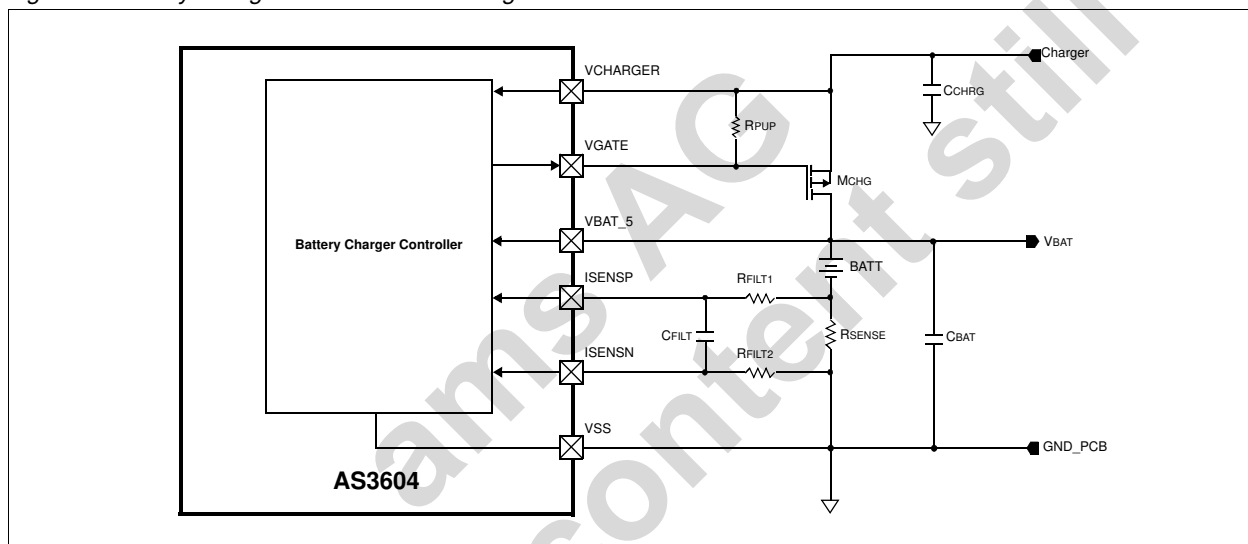

Table 3. Battery Charger Controller Components

Symbol	Parameter	Value	Notes
MCHG	P-Channel MOSFET	Si3441BDV, Si8401DB or similar	The maximum power dissipation of this transistor is not limited by the AS3604.
RPUP	Pull-Up Resistor	$2K\Omega \pm 5\%$	
RSENSE	Current Sense Resistor	$50m\Omega \pm 1\%$ , 125mW for $I_{VBAT,DC} < 1.5A$	e.g. Vishay Dale WSL0805
RFILT1,2	Filter Resistor	$47K\Omega \pm 1\%$	Can be omitted if Gas Gauge functionality is not used ( $RFILT1,2 = 0\Omega$ )
CFILT	Filter Capacitor	$100nF \pm 20\%$ , X5R or X7R Dielectric	
CCHRG	Bypass Capacitor on pin VCHARGER	$1\mu F \pm 20\%$ , X5R or X7R Dielectric	
CBAT	Minimum Total Capacitance Parallel to Battery	$10\mu F$	



Table 4. Battery Charger Controller Parameters

Symbol	Parameter	Min	Typ	Max	Unit	Notes
VCHDET	Charger Detection Threshold. VCHARGER - VBAT_5: Charger On	50	75	105	mV	Hysteresis = (VCHDET - VCHMIN) < 40mV
VCHMIN	Charger Detection Threshold. VCHARGER - VBAT_5: Charger Off	5	20	35	mV	
VCHREG	Bootstrap Regulator Voltage	2.4	2.5	2.6	V	VCHARGER > 5V
VCHOVH	VCHARGER Overvoltage Detection	6.2	6.45	6,71	V	Monitor voltage on VCHARGER and disable charging if this voltage is exceeded.
VCHOV		5,81	6.05	6,29		
VUVLO	Undervoltage Lockout Threshold		3.1		V	VBAT rising
			2.8			VBAT falling
VOVLO	Overvoltage Lockout Threshold		5.5		V	VBAT rising
			5.4			VBAT falling
VCHOFF	Charge Termination Threshold	4.14	4.20	4.26	V	Li+ Battery: <b>BatType</b> (page 20) = 0, <b>Li4v2</b> (page 20) = 1
		4.05	4.1	4.15		Li+ Battery: <b>BatType</b> = 0, <b>Li4v2</b> = 0. From -5 to +50°C
		5.44	5.5	5.6		NiMh Battery: <b>BatType</b> = 1
VNOBATDET	No-Battery Detection Threshold and Charger Resume Detection Threshold		3.644		V	<b>DisOWB</b> (page 21) = 0

### 6.1.1 Low-Current Trickle Charge Mode

Low-Current Trickle Charge mode is initiated when an external battery charger has been detected, bit **chDet** (page 19) = 1, and the battery voltage is below the **vuvlo** threshold; bits **ChAct** (page 19) and **Trickle** (page 19) will be set. In Trickle Charge mode the charge current will be limited to the value specified by **Trickle Current** (page 21) to prevent undue stress on either the battery or the Battery Charger in case of deeply discharged batteries.

Once **vuvlo** has been exceeded, the Battery Charger will terminate Trickle Charge mode (charger must not be disabled between trickle and constant current (fast) charging), reset bits **ChAct** and **Trickle**, and switch on the device.

The trickle charge is terminated in any case after approximately 60 minutes (as it is assumed that the battery is damaged in this case)

### 6.1.2 Constant Current Charge Mode

Constant Current mode is initiated by setting bit **ChEn** (page 20) and resetting bit **Fast** (page 20). Bit **ChAct** (page 19) is set automatically when the Battery Charger starts. Charge current will be limited to the value specified by bit **Constant Current** (page 21) by the Battery Charger Controller.

### 6.1.3 Charging Nickel-based Batteries

For nickel-based batteries (NiMh), **BatType** (page 20) must be 1 (see Figure 4 on page 9). The endpoint detection ( $\Delta V / \Delta t$ ) must be performed by the host controller. It must turn off the charger duly to avoid overcharging. In any case, when the battery voltage exceeds the charge termination threshold (typ. 5.5V), the charger will be turned off and bit **EOC** (page 20) will be set.

### 6.1.4 Charging Lithium-based Batteries

For lithium-based batteries (Lithium-Ion, Lithium-Polymer), **BatType** (page 20) must be 0. Additionally, bit **Li4v2** (page 20) can select between coke- and graphite-anode, setting different charge termination thresholds (typ. 4.1 or 4.2V). The charger is designed to charge 1-cell lithium-based batteries independently, using Trickle Charge, Constant Current, Constant Voltage, or Pulse Charge modes.

When the battery voltage exceeds the charge termination threshold during Constant Current mode, it automatically continues charging with either Constant Voltage mode, bit **Pulse** (page 20), or Pulse Charge mode, **Pulse**, and terminates when the end-of-charge conditions are met (see Figure 5 on page 11 and Figure 6 on page 13).

Figure 4. Startup and Constant Current Charging of Nickel-based Batteries

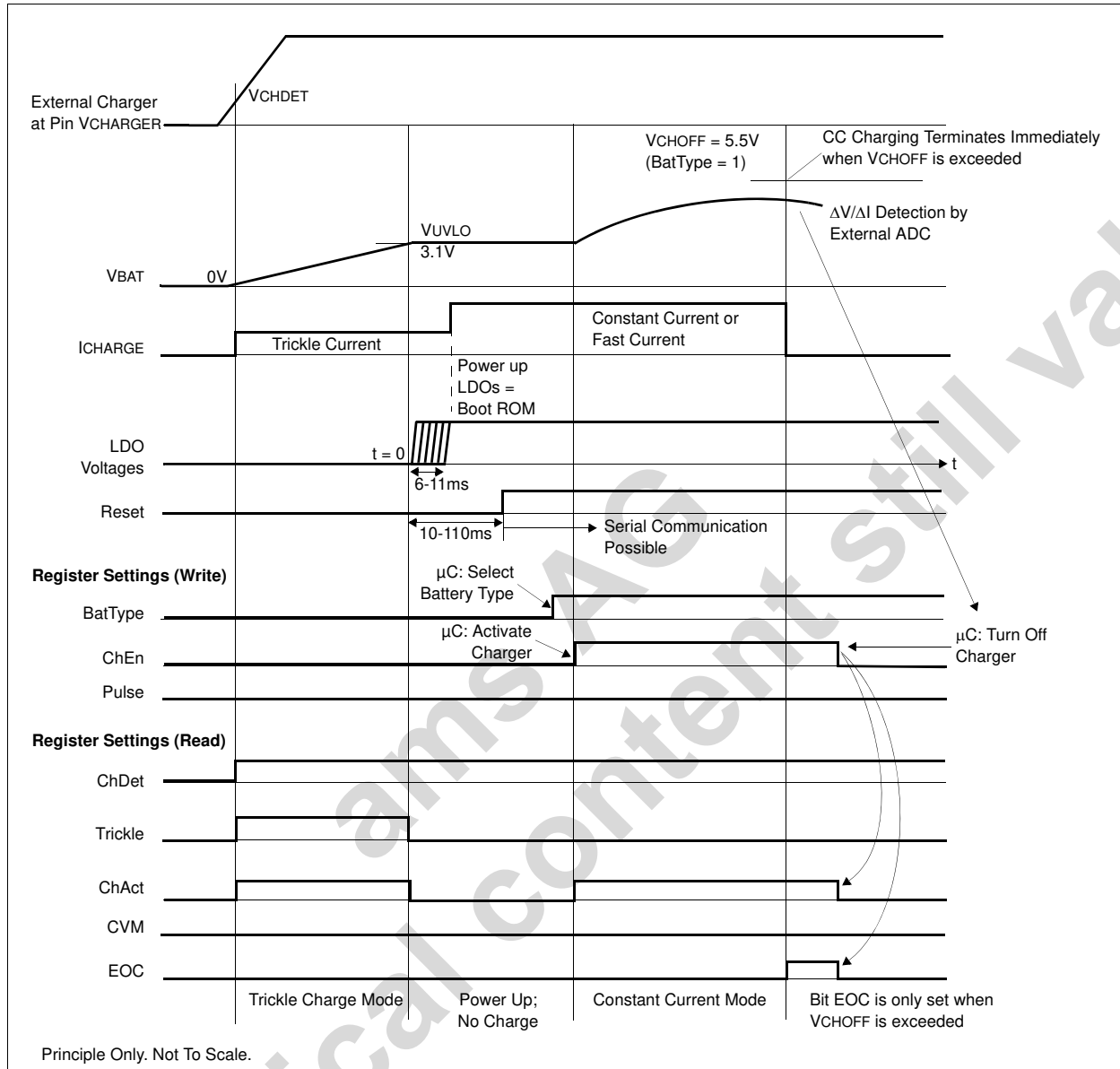

### 6.1.5 Fast Charge Mode

As an alternative to Constant Current mode, Fast Charge mode may be selected. The charge current will not be controlled in this mode and is only limited by the external battery charger adapter.

Fast Charge mode is initiated by setting bits **ChEn** (page 20) and **Fast** (page 20). Bit **ChAct** (page 19) is set when the Battery Charger has started.

#### End of Charge

In Fast Charge mode, the same charge termination thresholds apply as for Constant Current mode. Additionally, depending on bit **Fast** (page 20), the current during pulse charging is either the selected constant current or maximum. Charging will resume if the battery voltage drops below  $V_{NOBATDET}$ .

### 6.1.6 Constant Voltage Charge Mode

Constant Voltage mode is initiated and bit **CVM** (page 19) will be set when threshold  $V_{CHOFF}$  (page 8) has been exceeded for the first time (no debounce filter) and bit **Pulse** (page 20) is not set.

The charge controller will regulate the battery voltage to a value set by bit **Li4v2** (page 20). To enable operation of the device without a battery connected to the system it is necessary that the charger is not disabled between the moment when the  $V_{CHOFF}$  threshold is exceeded for the first time and the beginning of constant voltage charge mode.

- During Constant Voltage mode, the charge current will decrease and eventually drop below the value set by **Trickle Current** (page 21). If the measured charge current is less than or equal to **Trickle Current**, charging is terminated and bit **EOC** is set. Charging will resume if the battery voltage drops below  $V_{NOBATDET}$ .  
If the battery has been removed during constant voltage charging the EOC condition and the no battery condition will probably conflict. To be able to properly detect the **EOC** state the EOC condition has to be dominant over the no battery condition.
- If the battery voltage ( $V_{BAT\_5}$ ) drops below  $V_{NOBATDETECT}$  (page 8) (signal resume starts pulsing), e.g. if the battery is removed after charging is finished, **EOC** (page 20) will be cleared (after debounce time) and the battery charger controller will resume in constant voltage mode to enable operation of the device without battery. This only works if bit **CVM** (page 19) remains set when bit **EOC** is set, otherwise the comparators that are required for operation without battery are gated.

Three scenarios are possible at this point:

1. If a battery is connected the charge current will now be high and charging will return to constant current charging.
2. No battery is connected and no current will flow through the sense resistor. Now the no battery condition is detected properly.
3. The battery was connected and is disconnected. No current will flow through the sense resistor and the no battery condition is detected properly.

In summary: When charging is resumed after an **EOC** state either a (dis)charge current will be measured and the charge controller will return to constant current mode or no current will be measured and a “no battery” condition is indicated. To be able to handle supply voltage spikes caused by e.g. battery bouncing when the system is heavily shaken the  $V_{NOBATDETECT}$  detection has to be debounced for 1 current measurement cycle before **EOC** is cleared. After the debounce time is over additional pulses must occur during the next current measurement cycle to clear **EOC**. The no battery status is indicated with bit **NoBat** (page 20).

If the battery is replaced after charging is finished and the charge current exceeds the value set by **Constant Current** (page 21), the charge controller will clear bit **CVM** and return to Constant Current or Fast Charge mode, depending on bit **Fast** (page 20).

**Notes:**

1. Bit **CVM** will be ambiguous if bit **Fast** is set.
2. **EOC** will only be entered if bit **AutoChgTerm** (page 21) is set (default = 0).

Figure 5. Startup and Constant Voltage Charging of Lithium-based Batteries

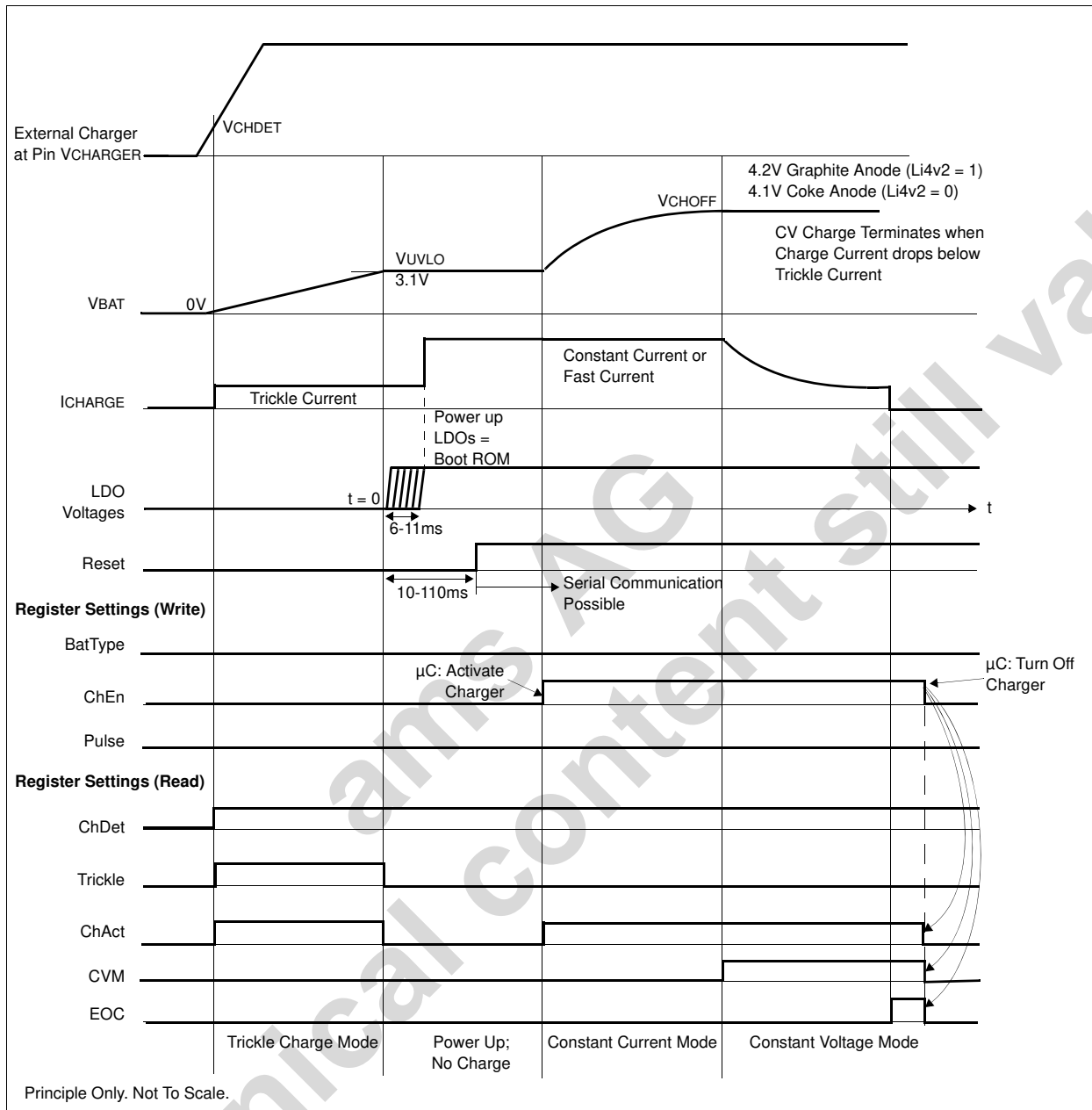

### 6.1.7 Pulse Charge Mode

Pulse Charge mode is initiated and bit **CVM** (page 19) will be set when the **VCHOFF** (page 8) threshold has been exceeded for the first time and bit **Pulse** (page 20) is set. If the battery voltage is below the **VCHOFF** threshold, the Battery Charger will be enabled for a minimum on-time specified by bit **TPON** (page 21).

If the battery voltage drops below **VCHOFF** at the end of the minimum on-time, the Battery Charger will remain switched on until the battery voltage exceeds **VCHOFF**. The Battery Charger will then be disabled for at least the minimum off-time specified by bit **TPOFF** (page 21), and the Battery Charger will only be switched on again when the battery voltage falls below **VCHOFF**. In any case, whenever the instantaneous battery voltage exceeds the overvoltage lockout threshold **Vovlo**, charging is disabled immediately.

During on-pulses, the charge current will be limited to the value set by **Constant Current (page 21)** if bit **Fast (page 20)** = 0. If bit **Fast** = 1, the charger transistor Q1 (page 2) will be fully on and the charge current during on-pulses will only be limited by the external charge adapter.

At the beginning of a Pulse Charge cycle, the Battery Charger will operate at a duty cycle close to 100%. Toward the end of the Pulse Charge cycle the Battery Charger will be switched off for long periods between short on-pulses. Eventually, the off-time will become longer than the value specified by bit **TPOFFMAX (page 21)**, and the charging cycle will terminate (bit **EOC (page 20)** is set). Charging will resume if the battery voltage drops below  $V_{NOBATDET}$ .

If the battery voltage drops below  $V_{NOBATDETECT}$  (page 8), e.g. if the battery is removed after charging is finished, **EOC (page 20)** will be cleared and the battery charger controller will resume in pulse charge mode to enable operation of the device without battery. The no battery status is indicated with bit **NoBat (page 20)**.

If the battery is replaced after charging is finished and the on-pulse duration **TPON (page 21)** becomes longer than **TPOFFMAX (page 21)**, the charge controller will clear bit **CVM (page 19)** and return to Constant Current or Fast Charge mode, depending on bit **Fast (page 20)**.

**Note:** With **TPOFFMAX** = 11 (no termination), the condition for returning to Constant Current or Fast Charge mode will never be met. Bit **CVM** will be ambiguous in this case.

If **AutoChgTerm (page 21)** is 0, the battery continues to be charged after EOC.

During on-pulses the instantaneous battery voltage may exceed  $V_{CHOFF}$  by several hundred millivolts. However, no harm will be done to the battery if **TPON (page 21)** is selected to be shorter than the electrochemical time constant of the battery.

By adding an external gate-source capacitor the switching edges of the P-channel MOSFET can be slowed down further. This prevents an external battery charge adapter with poor transient response from subjecting the  $V_{CHARGER}$  pin to excessive voltage when the P-channel MOSFET turns off, and prevents excessive current into the battery when the P-channel MOSFET turns on.

Figure 6. Startup and Pulse Charging for Lithium-Based Batteries

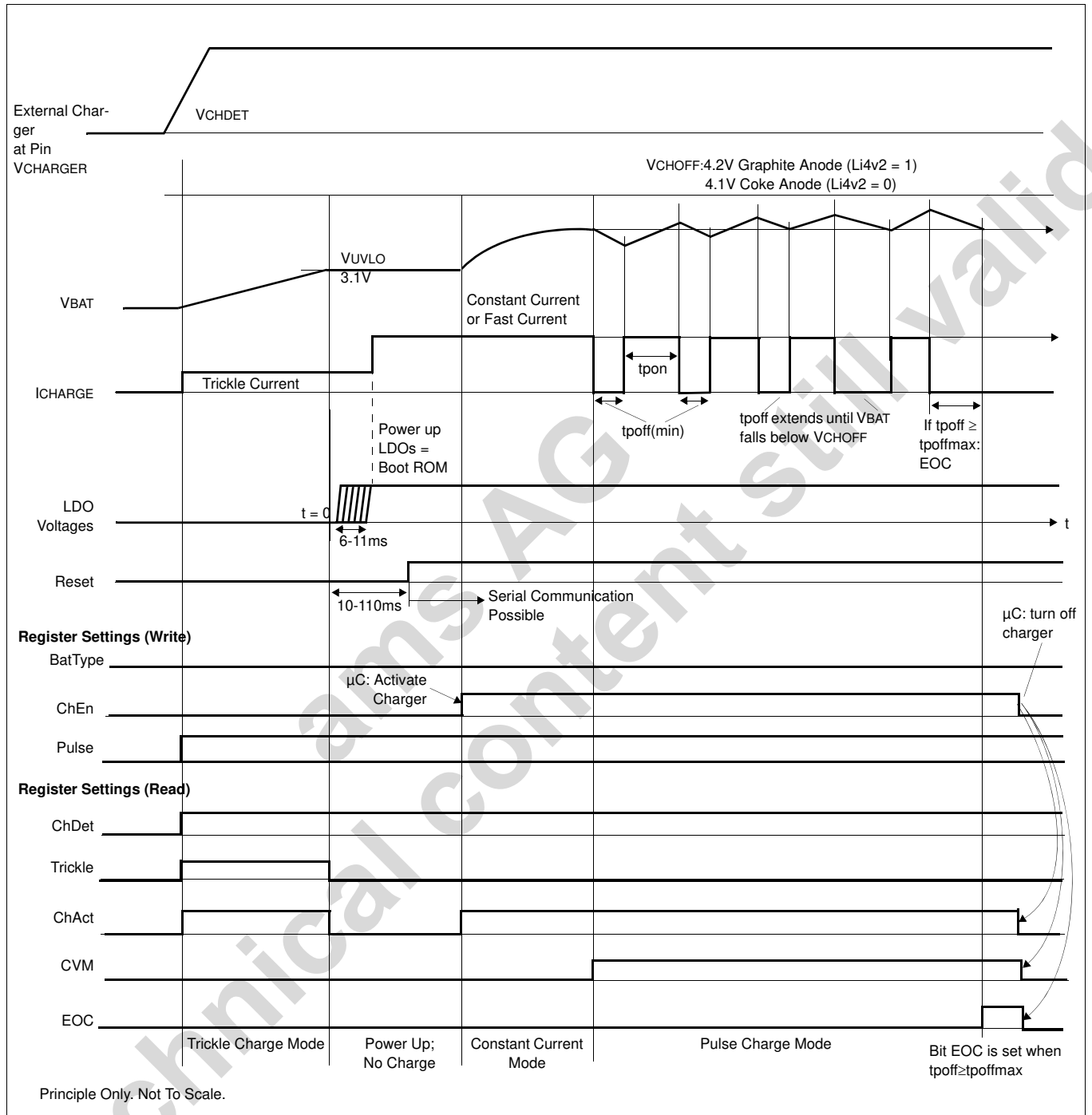

### 6.1.8 Battery Presence Detection

When active, the charge controller constantly monitors the voltage drop across an external current sense resistor ( $R_{SENSE}$ ) connected in series between the negative battery terminal and ground. In case no battery is connected to the system, no current can flow through  $R_{SENSE}$ . If no (dis)charge current flow is detected, bits **NoBat** (page 20) and **CVM** (page 19) will be set.

If a battery is re-connected to the system, current will be flowing through  $R_{sense}$ . If a (dis)charge current flow is detected, **NoBat** and **CVM** will be cleared. Battery presence indication can be disabled by setting bit **DisBDet** (page 21).

### 6.1.9 Operation Without Battery

This feature allows operation of the device without a battery if a charge adapter is applied to the VCHARGER pin and bit **ChEn** (page 20) is set. The battery voltage is regulated to the charge termination threshold  $V_{CHOFF}$  (page 8), depending on the setting of bits **BatType** (page 20) and **Li4v2** (page 20).

Note that when the charge controller is disabled by clearing bit **ChEn** e.g., during measurement of the battery voltage by an external ADC, the device will be reset when the battery is removed. The "operation without battery" feature can be disabled by setting **DisOWB** (page 21). The minimum required capacitance on  $V_{BAT}$  (all buffer caps combined) must be  $\geq 10\mu F$  to reduce the ripple on  $V_{BAT}$  when operating the AS3604 without battery.

### 6.1.10 Charge Controller Bypass

The charge controller can be bypassed by setting bit **Bypass** (page 20). In bypass mode, the charger transistor Q1 (page 2) is fully on. The overvoltage protection however will turn off the transistor, when  $V_{BAT} \geq V_{OVLO}$  (page 8). End-of-charge detection is disabled and has to be performed by the system host, bit **EOC** is cleared.

Removal of the charge adapter will be indicated in the **Charger Status Register** (page 19) but the charge controller will not be disabled. This feature is especially useful when using current-limited charge adapters with an output voltage close to the charge termination threshold and the system is operating without battery. Note that when the voltage difference between the charge adapter output voltage and the battery is smaller than  $V_{CHMIN}$  (page 8) the charger detection circuit will indicate that no charge adapter is connected. Furthermore, Trickle Charge mode is not supported in bypass mode because the current regulation is overruled by bit **Bypass**.

Figure 7. Battery Charger Flow Chart

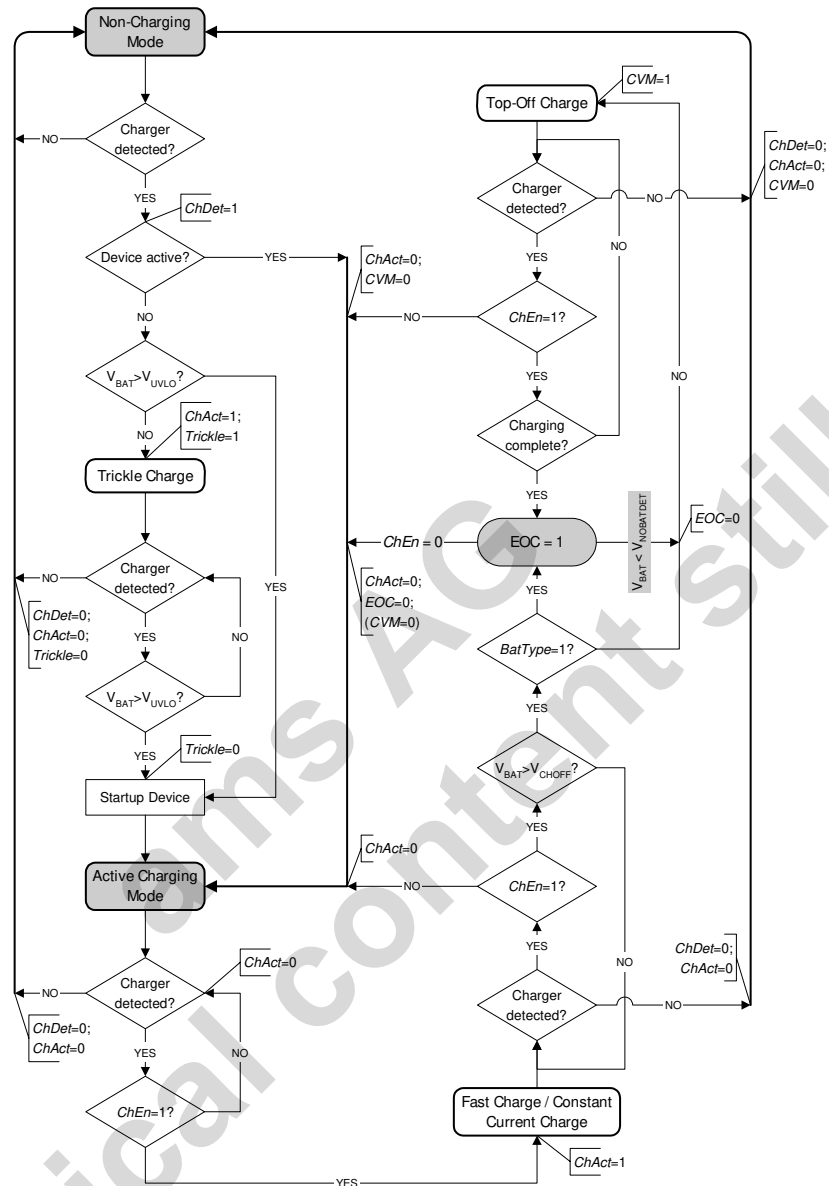

### 6.1.11 Overvoltage and Undervoltage Supervision

When the battery voltage exceeds the  $V_{OVLO}$  (page 8) threshold ( $V_{BAT}$  rising), the charger transistor Q1 (page 2) is turned off. Charging will resume if the battery voltage drops below  $V_{OVLO}$  ( $V_{BAT}$  falling).

Likewise, when the battery voltage drops below the Undervoltage Lockout Threshold  $V_{UVLO}$  ( $V_{BAT}$  falling) (page 8), a Reset is generated (page 56), which also clears bit **ChEn** (page 20).

The charger will remain in low current Trickle Charge mode (page 8) until the  $V_{UVLO}$  threshold ( $V_{BAT}$  rising) has been exceeded.

If **ChOv** (page 21) = 1, the AS3604 monitors the voltage on pin VCHARGER. If the voltage on VCHARGER exceeds  $V_{CHOV}$  (bit **ChOvH** (page 21) = 0) or  $V_{CHOVH}$  (bit **ChOvH** = 1) the Battery Charger stops. If the voltage subsequently drops below this limit, the Battery Charger automatically resumes charging.



### 6.1.12 Charger Detection Circuit

The Battery Charger Controller uses an integrated Charger Detection Circuit to determine if an external battery charger adapter has been applied to pin VCHARGER.

Charger register bits will be set/reset when any of the following conditions are met:

1. When the charger voltage exceeds the battery voltage by  $V_{CHDET}$  (page 8), Bit **chDet** (page 19) will be set.
2. When the charger voltage drops below  $V_{CHMIN}$  (page 8) above the battery voltage, bit **chDet** will be reset. If the charger was active, bit **ChEn** (page 20) = 1, bit **ChAct** (page 19) will also be reset. Charging will resume when the conditions for bit **chDet** = 1 are met.
3. If a Reset occurs during charging, the charger will also be reset (**ChAct** = 0). Bits **ChEn** and **chDet** will remain set to 1. To resume charging, the charger must be turned off (**ChEn** = 0) and then on (**ChEn** = 1).

### 6.1.13 Bootstrap Voltage Regulator

To charge even completely discharged batteries, the AS3604 contains an internal bootstrap voltage regulator (LDO V2\_5) which generates a bootstrap voltage ( $V_{CHREG}$ ) to supply power to the internal Battery Charger circuitry.

### 6.1.14 Battery Charger Operation

The Battery Charger Controller controls an 8-bit current DAC which delivers a current ( $I_{DAC}$ ) that will generate a voltage ( $V_{GS}$ ) over an external resistor ( $R_{GS}$ ) connected between the gate and source of an external P-channel MOSFET.

#### Charge Current Regulator

The Charge Current Regulator has a resolution of 0.625mV or 12.5mA when using a 50mΩ sense resistor. The resolution is programmable using the **Charger Control Register** (page 20).

Table 5. Charge Current Regulator Parameters

Symbol	Parameter	Min	Typ	Max	Unit
$I_{VGATE,LSB}$	Resolution of $V_{GATE}$ current; bit <b>Boost</b> (page 20) = 0		0.5		μA
$I_{VGATE,FS}$	Full-scale value of $V_{GATE}$ current; bit <b>Boost</b> = 0		127.5		μA

**Note:** Setting bit **Boost** (page 20) = 1 multiplies this current by a factor of 10.

### 6.1.15 Charger Total Current Regulation

During normal operation, the AS3604 controls the charging current through the battery. Alternatively, it is possible to regulate the maximum current from the charger (see Figure 8).

If the shunt resistor is connected as shown in Figure 8, the charger regulates the current from the charger adapter. The internal register bit **AutoChgTerm** (page 21) must be set to 0 in this configuration. If **AutoChgTerm** is reset, the charger is not switched off if an end-of-charge condition is reached (only an interrupt is sent to the baseband processor).

If the end-of-charge interrupt is sent to the baseband processor, the baseband processor can terminate the charging cycle by setting bit **AutoChgTerm** to 1. This should only be done if a battery is present. If bit **AutoChgTerm** is 1 and the battery is subsequently removed, the baseband processor should immediately reset bit **AutoChgTerm** to 0 and bit **ChEn** (page 20) should be set to 0 and then to 1 again to restart the charger and avoid a reset cycle of the system due to undervoltage condition on the battery.

To avoid a reset cycle of the system under any condition, bit **AutoChgTerm** should usually be left at 0.

**Note:** The AS3604 measures the current from the charger including the current used for charging the battery and the current flowing to the whole system. The end-of-charge detection is done by comparing this current against the value set in the bits **Trickle Current** (page 21). Therefore this value has to be set sufficiently high to obtain a proper end-of-charge condition. If this is not possible, a timeout timer inside the baseband processor should be set allowing for an end-of-charge indication in the user interface.

Figure 8. Total Current Regulation

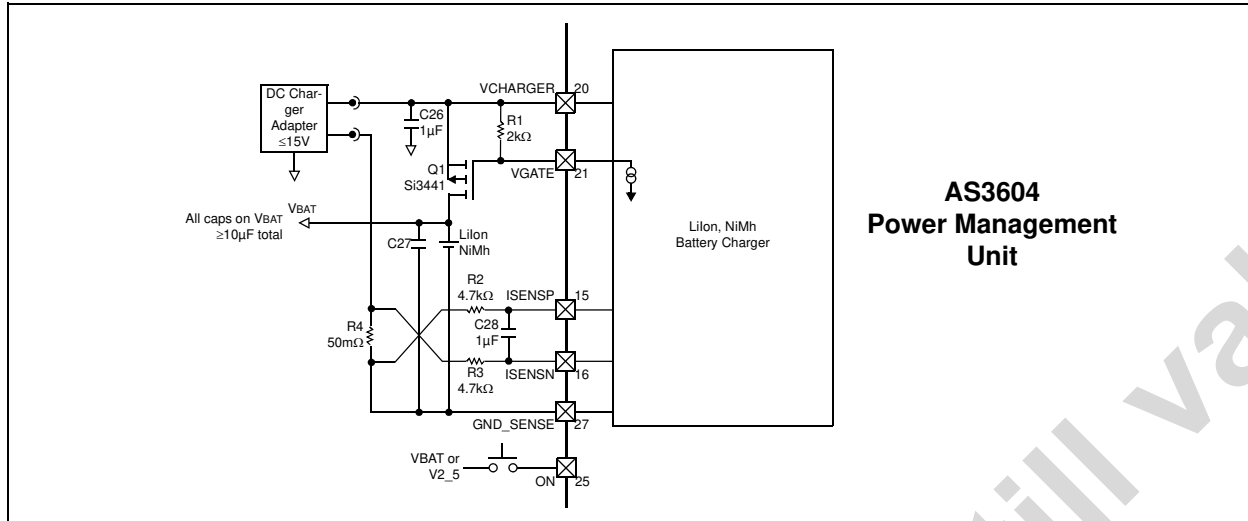

### 6.1.16 Gas Gauge

The Gas Gauge enables remaining capacity estimation of the battery by tracking the net current flow into and out of the battery using a Voltage-to-Frequency Converter.

Table 6. Gas Gauge Parameters

Symbol	Parameter	Min	Typ	Max	Unit	Notes
fCLK	Internal Reference Clock	1.0	1.1	1.2	MHz	
fVFC	Sample Frequency		fCLK/59		Hz	fCLK: internal reference clock.
VISENSP/ VISENSN	Input Voltage	-0.1		0.1	V	
ZISENSP/ ZISENSN	Input Impedance	4.67			MΩ	
AVFC	(Dis)Charge Gain		91.0		Hz/V	fCLK = 1.1MHz
FRVFC	Fundamental Rate		3.05		μVh	
VOFF	Uncompensated Offset Voltage	-500		500	μV	Offset voltage ISENSP - ISENSN
VOFF,COMP	Compensated Offset Voltage	-50	±10	50	μV	Offset error after offset compensation

#### Voltage-to-Frequency Converter

The Voltage-to-Frequency Converter constantly monitors the voltage drop across an external current sense resistor (RSENSE) connected in series between the negative battery terminal and ground.

The use of an additional external RC lowpass filter is highly recommended. Using two 47kΩ resistors, R2 and R3 (page 2), and a 0.1μF ceramic capacitor, C28 (page 2), the filter cutoff is approximately 16.9 Hz. This filter will capture the effect of most spikes, and will thus allow the Gas Gauge to accurately detect the total charge that has gone into or out of the battery.

#### Charge Current Accumulator

The Charge Current Accumulator is an internal 15-bit up/down counter with sign bit. It is incremented when current is charged into the battery and decremented when current is drawn out of the battery. It is updated at a rate of one count per 3.05μVh, which is equivalent to one count per 61.03μAh (using a 50mΩ current sense resistor).

If the counter is not read, it will roll over beyond FFFF<sub>h</sub>, which occurs after approximately 2000mAh of charge (using a 50mΩ sense resistor). It is the responsibility of the host system to read and reset the counter before rollover occurs.

The contents of the Charge Current Accumulator will be transferred into the **Delta Charge MSB Register** (page 22) and the **Delta Charge LSB Register** (page 22) when bit **UpdReq** (page 22) has been set. After the Delta Charge MSB/LSB registers have been updated successfully, bit **UpdReq** is cleared automatically and the Charge Current Accumulator will be reset along with bit **sign**.

### Constant Voltage Regulator

The Constant Voltage Regulator acts directly on the setting of the 8-bit current DAC. It will commence when threshold  $V_{CHOFF}$  (page 8) has been exceeded for the first time as long as bit **Pulse** (page 20) is not set.

### Elapsed Time Counter

The sample clock ( $f_{VFC}$ ) of the Gas Gauge is fed to a 14-bit clock count divider, whose output signal is used as a clocking signal for the 16-bit Elapsed Time Counter, resulting in an equivalent rate of 1.1379 counts per second (4096.60 counts = 1 hour, 1 count = 0.8788s).

The Elapsed Time Counter can rollover beyond  $FFFF_h$  which occurs after about 16 hours. If this happens the value given by the counter will be ambiguous. It is the responsibility of the host system to read the Elapsed Time Counter before rollover occurs.

The content of the Elapsed Time Counter is transferred into the **Elapsed Time MSB Register** (page 23) and the **Elapsed Time LSB Register** (page 23) when bit **UpdReq** (page 22) has been set. After the Elapsed Time MSB/LSB registers have been updated successfully, bit **UpdReq** is cleared automatically and the Elapsed Time Counter is reset.

### Offset Calibration Mode

Although the Voltage-to-Frequency Converter compensates for the offset of the Integrator, the Gas Gauge features an additional offset calibration mode to enhance the measurement accuracy even further. By setting bit **CalReq** (page 22) the Integrator is reset and the offset calibration mode is activated.

The offset is accumulated during 16 clocks of the elapsed time counter ( $16 \times 0.8788s = 14.06$  sec). When offset calibration is complete, bit **CalReq** is cleared automatically and the offset value is transferred into the **Delta Charge MSB Register** (page 22) and the **Delta Charge LSB Register** (page 22) for calculating the actual average current (page 18).

The calculated value defines the measured offset between  $I_{SENSP}$  and  $I_{SENSN}$ . It has a resolution of  $3.05\mu V$ . This offset value is used as a correction factor for calculating the actual average current.

**Note:** Offset calibration is not possible while the charger is active. If bit **CalReq** is set while the charger is active, the calibration will start automatically after the charger has been disabled by clearing bit **ChEn** or if the external battery charger adapter has been removed. If, during offset calibration, the charger is enabled, offset calibration mode is terminated, bit **CalReq** is cleared, the current value of the Elapsed Time Counter is transferred to the Elapsed Time MSB/LSB registers, and the Delta Charge MSB/LSB registers are loaded with  $FFFF_h$ .

### Calculation of Battery Status

The host system can calculate all the parameters necessary for estimating the remaining battery capacity by evaluating  $FGOffCal$  (the Elapsed Time MSB/LSB (page 23) and the Delta Charge MSB/LSB (page 22) registers).

### Calculating Elapsed Time

The host system can evaluate the change in time ( $\Delta t$ ) by setting bit **UpdReq** (page 22) and reading the Elapsed Time MSB/LSB registers after bit **UpdReq** has been automatically cleared. The change in time in seconds is given by:

$$\Delta t = ElapsedTime \times 3600 / 4096.60 [s] \quad (EQ 1)$$

The absolute accuracy of ( $\Delta t$ ) is directly related to the absolute accuracy of  $f_{CLK}$ . To cancel errors associated with the accuracy of the oscillator, a correction factor ( $CV$ ) can be introduced.  $CV$  can be evaluated by comparing the change in time calculated by (EQ 1) with a reference value ( $\Delta t_{REF}$ ) obtained from a RTC or measured during system calibration.  $CV$  is given by:

$$CV = \Delta t_{REF} / \Delta t \quad (EQ 2)$$

By multiplying  $\Delta t$  with  $CV$ , the correct value for the change in time ( $\Delta t_{CORR}$ ) can be calculated:

$$\Delta t_{CORR} = CV \times \Delta t [s] \quad (EQ 3)$$

### Calculating Average Current

The host system can calculate the average current ( $I_{AVG}$ ) during the last time period by setting bit **UpdReq** (page 22) and reading the Delta Charge MSB/LSB registers and the Elapsed Time MSB/LSB registers after **UpdReq** has been automatically cleared. Together with  $FGOffCal$ , determined during offset calibration mode,  $I_{AVG}$  is given by:

$$I_{AVG} = DeltaCharge / (\Delta t \times AVFC \times R_{sense}) - FGOffCal \times 3.05 \mu V / R_{sense} [A] \quad (EQ 4)$$

$\Delta t$  is the change in time in seconds calculated by (EQ 1),  $AVFC$  is the gain of the Voltage-to-Frequency Converter in Hz/V,  $R_{SENSE}$  is the value of the sense resistor in ohms, and  $FGOffCal$  is the offset calibration value. As  $\Delta t$  and  $AVFC$  both are proportional to the oscillator frequency, no correction factor needs to be introduced in the formula.

### Calculating Accumulated Capacity

Accumulated capacity is used to calculate the absolute remaining capacity of the battery. It is given by:

$$Q_{ACC} = I_{AVG} \times \Delta t_{CORR} [As] \quad (EQ 5)$$

### Calculating the Remaining Capacity

Calculation of the remaining battery capacity ( $RC$ ) is the goal of the Gas Gauge. It is given by:

$$RC = RC + Q_{ACC} [As] \quad (EQ 6)$$

### Calculating the Time to Empty

Time to empty ( $t_{te}$ ) is calculated from the average current ( $I_{AVG}$ ) given by (EQ 4). The longer the time period for which  $I_{AVG}$  is calculated, the more accurate the value for  $I_{AVG}$  and therefore the estimated  $t_{te}$  will be. It is given by:

$$t_{TE} = RC / I_{AVG} [s] \quad (EQ 7)$$

## 6.1.17 Battery Charger Controller Registers

The Battery Charger Controller is controlled by the registers listed in Table 7.

Table 7. Battery Charger Controller Register Summary

Name	Addr	B7	B6	B5	B4	B3	B2	B1	B0	Page
Charger Status Register	53	Bypass	NoBat	EOC	CVM	Trickle	IntReg	ChAct	chDet	19
Charger Control Register	20	ChOvEn	Boost	Bypass	Pulse	Li4v2	Fast	BatType	ChEn	20
Charger Timing Register	44	TPOFFMAX		TPOFF			TPON			21
Charger Current Register	22	ChOv	ChOvH	Bat_v	ConstantCurrent			TrickleCurrent		21
Charger Config Register	66	N/A	AutoChg Term	CVMtst	DisOWB	DisBDet	Dis Hyst	Wide	N/A	21
Gas Gauge Register	21	N/A				CalMod	CalReq	UpdReq	FGEn	22
Delta Charge MSB Register	54	sign	214	213	212	211	210	29	28	22
Delta Charge LSB Register	55	27	26	25	24	23	22	21	20	22
Elapsed Time MSB Register	56	215	214	213	212	211	210	29	28	23
Elapsed Time LSB Register	57	27	26	25	24	23	22	21	20	23
PreCurDac Register	67	27	26	25	24	23	22	21	20	23

Addr: 53		Charger Status Register			
Displays status of Battery Charger Controller.					
Bit	Bit Name	Default	Access	Bit Description	
0	chDet	00h	R	0 = No external battery charger detected. 1 = External battery charger adapter has been detected. Charger voltage exceeds battery voltage by $V_{CHDET}$ .	
1	ChAct	00h	R	0 = Charger is off or in Trickle Charge mode. 1 = Charger is in Constant Current, Fast Charge, or Pulse Charge mode.	
2	IntReg	00h	R	0 = Bit is cleared when $V_{BAT} > V_{UVLO}$ . 1 = LDO V2_5 is operating.	
3	Trickle	00h	R	0 = Trickle charging is off. 1 = Charger is in Trickle Charge mode. Trickle current is set by the <b>Charger Current Register</b> (page 21).	
4	CVM	00h	R	0 = Battery charger is not in top-off charge mode. 1 = Battery charger is in top-off charge mode (constant voltage or pulse charge mode).	

Addr: 53		Charger Status Register		
Displays status of Battery Charger Controller.				
Bit	Bit Name	Default	Access	Bit Description
5	EOC	00 <sub>h</sub>	R	0 = Battery charger is off or charging is in progress; automatically cleared when <b>ChEn (page 20)</b> is cleared. 1 = End of Charge. Automatically set when CV or pulse charging is completed or when V <sub>CHOFF</sub> is exceeded during charging of Ni-based batteries.
6	NoBat	00 <sub>h</sub>	R	No battery detection. 0 = Battery is connected, when <b>DisBDet (page 21)</b> is set, and/or <b>ChEn (page 20)</b> is cleared. 1 = No battery detected at V <sub>BAT</sub> .
7	Bypass	00 <sub>h</sub>	R	Indicates charger bypass mode. 0 = Normal charger operating mode. 1 = Indicates that charger is in bypass mode; charger transistor Q1 (page 2) is fully on and EOC detection is disabled.

Addr: 20		Charger Control Register		
Controls operation of the Battery Charger Controller.				
Bit	Bit Name	Default	Access	Bit Description
0	ChEn	Boot ROM	R/W	0 = Disables charging. 1 = Enables charging.
1	BatType	Boot ROM	R/W	<b>Li4v2</b> 00 = Li-ion battery with coke anode; V <sub>CHOFF</sub> (page 8) = 4.1V 10 = Li-ion battery with graphite anode; V <sub>CHOFF</sub> = 4.2V x1 = Nickel-based battery; V <sub>CHOFF</sub> = 5.52V
2	Fast	Boot ROM	R/W	0 = Selects Constant Current charge mode. 1 = Selects Fast Charge mode.
3	Li4v2	Boot ROM	R/W	Selects the type of lithium-based battery. 0 = V <sub>CHOFF</sub> (page 8) = 4.1V for Li+ battery with coke anode. 1 = V <sub>CHOFF</sub> = 4.2V for Li+ battery with graphite anode.
4	Pulse	Boot ROM	R/W	Selects top-off charging mode. 0 = Select constant voltage charging mode. 1 = Select pulse charging mode.
5	Bypass	Boot ROM	R/W	Enable bypassing of charge controller. 0 = Normal charger operation. 1 = Select charger bypass mode; charger transistor Q1 (page 2) is fully on and EOC detection is disabled.
6	Boost	Boot ROM	R/W	Selects output of current DAC at pin VGATE. 0 = Nominal current (max. 128μA). 1 = 10x nominal current (default; max. 1.28mA).
7	ChOvEn	Boot ROM	R/W	0 = Disable automatic termination of charging. 1 = Enable automatic termination of charging.





Addr: 21		Gas Gauge Register		
Controls the Fuel Gauge.				
Bit	Bit Name	Default	Access	Bit Description
0	FGEn	0b	R/W	Controls the operation of the Gas Gauge. 0 = Disables Gas Gauge. 1 = Enables Gas Gauge.
1	UpdReq	0b	R/W	Controls the updates of the Delta Charge MSB/LSB registers and the Elapsed Time MSB/LSB registers. When set, this bit is cleared automatically after the Delta Charge MSB/LSB registers and the Elapsed Time MSB/LSB registers have been successfully updated. 0 = Indicates update of Delta Charge MSB/LSB registers and Elapsed Time MSB/LSB registers has been completed. 1 = Request update of Delta Charge and Elapsed Time Registers
2	CalReq	0b	R/W	Controls offset calibration. When set, this bit is cleared automatically after offset calibration has successfully completed. 0 = Indicates offset calibration has completed or forces termination of offset calibration. 1 = Request offset calibration.
3	CalMod	0b	R/W	Sets the offset calibration mode. 0 = Connect inputs to ground. 1 = Use ISENSP and ISENSN (for testing purposes only).
7:4				N/A

Addr: 54		Delta Charge MSB Register		
Holds the amount of charge since last reading.				
Bit	Bit Name	Default	Access	Bit Description
0	28	00 <sub>h</sub>	R	This register (along with Delta Charge LSB Register) is maintained in two's complement form with a resolution of 3.05 $\mu$ Vh and a full-scale value of $\pm$ 99.98mVh. When using a 50m $\Omega$ current sense resistor, this is equivalent to a resolution of 61.03 $\mu$ Ah and a full-scale value of 1.999Ah. The <b>sign</b> bit is set for negative values. This register will be updated after setting bit <b>UpdReq</b> (page 22) = 1.
1	29	00 <sub>h</sub>	R	
2	210	00 <sub>h</sub>	R	
3	211	00 <sub>h</sub>	R	
4	212	00 <sub>h</sub>	R	
5	213	00 <sub>h</sub>	R	
6	214	00 <sub>h</sub>	R	
7	sign	00 <sub>h</sub>	R	

Addr: 55		Delta Charge LSB Register		
Holds the amount of charge since last reading.				
Bit	Bit Name	Default	Access	Bit Description
0	20	00 <sub>h</sub>	R	This register (along with Delta Charge MSB Register) is maintained in two's complement form with a resolution of 3.05 $\mu$ Vh and a full-scale value of $\pm$ 99.98mVh. When using a 50m $\Omega$ current sense resistor, this is equivalent to a resolution of 61.03 $\mu$ Ah and a full-scale value of 1.999Ah. This register is updated after setting bit <b>UpdReq</b> (page 22) = 1.
1	21	00 <sub>h</sub>	R	
2	22	00 <sub>h</sub>	R	
3	23	00 <sub>h</sub>	R	
4	24	00 <sub>h</sub>	R	
5	25	00 <sub>h</sub>	R	
6	26	00 <sub>h</sub>	R	
7	27	00 <sub>h</sub>	R	

Addr: 56		Elapsed Time MSB Register		
Holds the elapsed time since last reading.				
Bit	Bit Name	Default	Access	Bit Description
0	28	00 <sub>h</sub>	R	This register (along with the Elapsed Time LSB Register) stores the elapsed time count with a resolution of 0.8788 seconds and a full-scale value of 15.997 hours. This register will be updated after setting bit <b>UpdReq</b> (page 22) = 1.
1	29	00 <sub>h</sub>	R	
2	2 <sup>10</sup>	00 <sub>h</sub>	R	
3	2 <sup>11</sup>	00 <sub>h</sub>	R	
4	2 <sup>12</sup>	00 <sub>h</sub>	R	
5	2 <sup>13</sup>	00 <sub>h</sub>	R	
6	2 <sup>14</sup>	00 <sub>h</sub>	R	
7	2 <sup>15</sup>	00 <sub>h</sub>	R	

Addr: 57		Elapsed Time LSB Register		
Holds the elapsed time since last reading.				
Bit	Bit Name	Default	Access	Bit Description
0	2 <sup>0</sup>	00 <sub>h</sub>	R	This register (along with the Elapsed Time MSB Register) stores the elapsed time count with a resolution of 0.8788 seconds and a full-scale value of 15.997 hours. This register will be updated after setting bit <b>UpdReq</b> (page 22) = 1.
1	2 <sup>1</sup>	00 <sub>h</sub>	R	
2	2 <sup>2</sup>	00 <sub>h</sub>	R	
3	2 <sup>3</sup>	00 <sub>h</sub>	R	
4	2 <sup>4</sup>	00 <sub>h</sub>	R	
5	2 <sup>5</sup>	00 <sub>h</sub>	R	
6	2 <sup>6</sup>	00 <sub>h</sub>	R	
7	2 <sup>7</sup>	00 <sub>h</sub>	R	

Addr: 67		PreCurDac Register		
Sets starting point for current DAC at pin VGATE.				
Bit	Bit Name	Default	Access	Bit Description
0	2 <sup>0</sup>	00 <sub>h</sub>	R/W	Sets the preset value for the current DAC at pin VGATE to speed up the startup, when the charge controller is enabled. Boost = 0:                      Boost = 1: 00 <sub>h</sub> = 0μA                      00 <sub>h</sub> = 0μA ...0.5μA                      ... 5μA FF <sub>h</sub> = 127.5μA                      FF <sub>h</sub> = 1.275mA
1	2 <sup>1</sup>	00 <sub>h</sub>	R/W	
2	2 <sup>2</sup>	00 <sub>h</sub>	R/W	
3	2 <sup>3</sup>	00 <sub>h</sub>	R/W	
4	2 <sup>4</sup>	00 <sub>h</sub>	R/W	
5	2 <sup>5</sup>	00 <sub>h</sub>	R/W	
6	2 <sup>6</sup>	00 <sub>h</sub>	R/W	
7	2 <sup>7</sup>	00 <sub>h</sub>	R/W	



## 6.2 Step Down DC/DC Converter

The step-down converter is a high-efficiency fixed frequency current mode regulator. By using low resistance internal PMOS and NMOS switches, efficiency up to 95% can be achieved. The fast switching frequency allows using small inductors, without increasing the current ripple. The unique feedback and regulation circuit guarantees optimum load and line regulation over the whole output voltage range, up to an output current of 500mA, with an output capacitor of only 10 $\mu$ F. The implemented current limitation protects the DC/DC Converter and the coil during overload condition.

Figure 9. Step Down DC/DC Converter Block Diagram

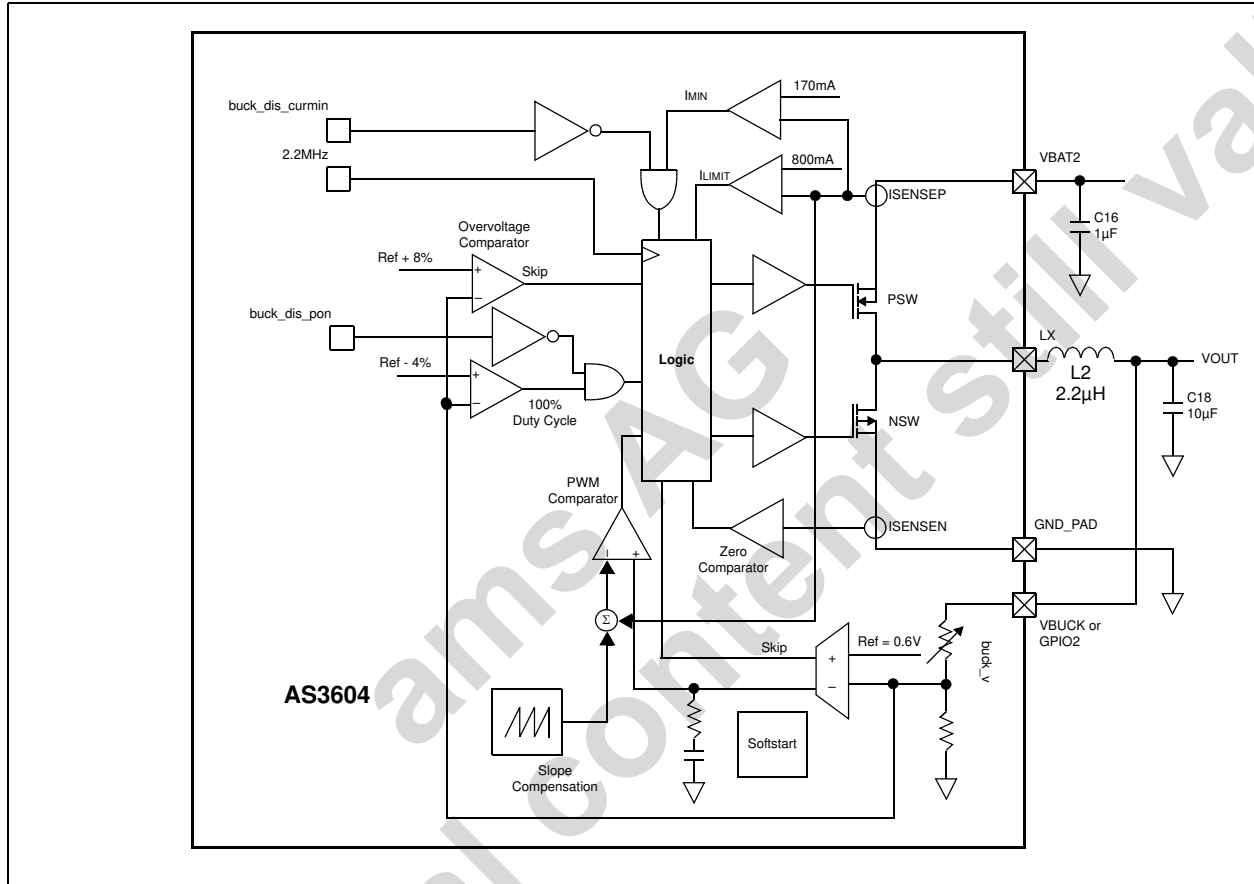

Table 8. Step Down DC/DC Converter Parameters

Symbol	Parameter	Min	Typ	Max	Unit	Notes
V <sub>IN</sub>	Input Voltage	3.0		5.5	V	Pin VBAT_2
V <sub>OUT</sub>	Regulated Output Voltage	0.6		3.3	V	Sense pin VBUCK (or GPIO2)
V <sub>OUT_TOL</sub>	Output Voltage Tolerance	-50		50	mV	Sense pin VBUCK (or GPIO2); Output Voltage < 2.0V
		-100		100		Sense pin VBUCK (or GPIO2); Output Voltage > 2.0V
I <sub>LIMIT</sub>	Current Limit		350		mA	Supply current into PMOS transistor
R <sub>PSW</sub>	PSW On-Resistance			0.5	Ω	
R <sub>NSW</sub>	NSW On-Resistance			0.5	Ω	
I <sub>LOAD</sub>	Load Current	0		500	mA	
f <sub>sw</sub>	Switching Frequency		2.2		MHz	
C <sub>OUT</sub>	Output Capacitor		10		μF	Ceramic
L <sub>x</sub>	Inductor		2.2		μH	
η	Efficiency		90		%	I <sub>LOAD</sub> = 100mA, V <sub>OUT</sub> = 2.3V, V <sub>BAT</sub> = 3V
9	Current Consumption		250			Operating Current; No Load
			100		μA	Quiescent Current; Low-Power Mode
			0.1			Shutdown Current
t <sub>MIN_ON</sub>	Minimum On Time		80		ns	
t <sub>MIN_OFF</sub>	Minimum Off Time		40		ns	

To allow optimised performance in different applications, there are bit settings possible, to get the best compromise between high efficiency and low input/output ripple.

### 6.2.1 Low-Ripple, Low-Noise Operation

Low-ripple, low-noise operation can be enabled by setting bit **buck\_dis\_curmin (page 29)** = 1. In this mode there is no minimum coil current necessary before switching off the PMOS. As result, the ON time of the PMOS will be reduced down to t<sub>MIN\_ON</sub> at no or light load conditions, even if the coil current is very small or the coil current is inverted. This results in a very low ripple and noise (but decreased efficiency) at light loads, especially at low input-to-output voltage differences.

**Note:** Because of the inverted coil current in that case the regulator will not operate in pulse skip mode.

Using bit **stepdown\_fb (page 46)**, the regulator feedback input can be configured at two pins:

- VBUCK – When used as feedback input, configures the Step Down DC/DC Converter as a pre-regulator for the digital LDOs (VDIG\_1 and VDIG\_2)
- GPIO2 – When used as feedback input, allows the digital LDOs (VDIG\_1 and VDIG\_2) to be connected to a separate input voltage source.

Figure 10. Bit `buck_dis_curmin` = 1 Operation

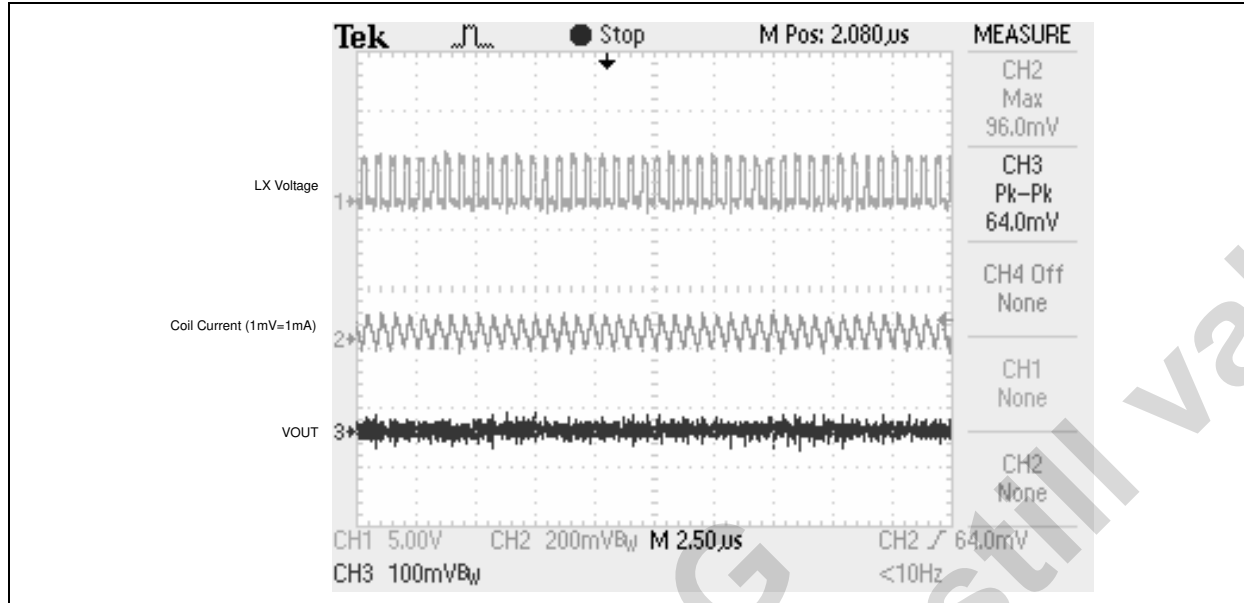

### 6.2.2 High-Efficiency Operation (Default Setting)

High-efficiency operation is enabled by setting bit `buck_dis_curmin` (page 29) = 0. In this mode there is a minimum coil current necessary before switching off the PMOS. As result there are less pulses at low output load necessary, and therefore the efficiency at low output load is increased. This results in higher ripple, and noisy pulse skip operation up to a higher output current.

Figure 11. Bit `buck_dis_curmin` = 0 Operation

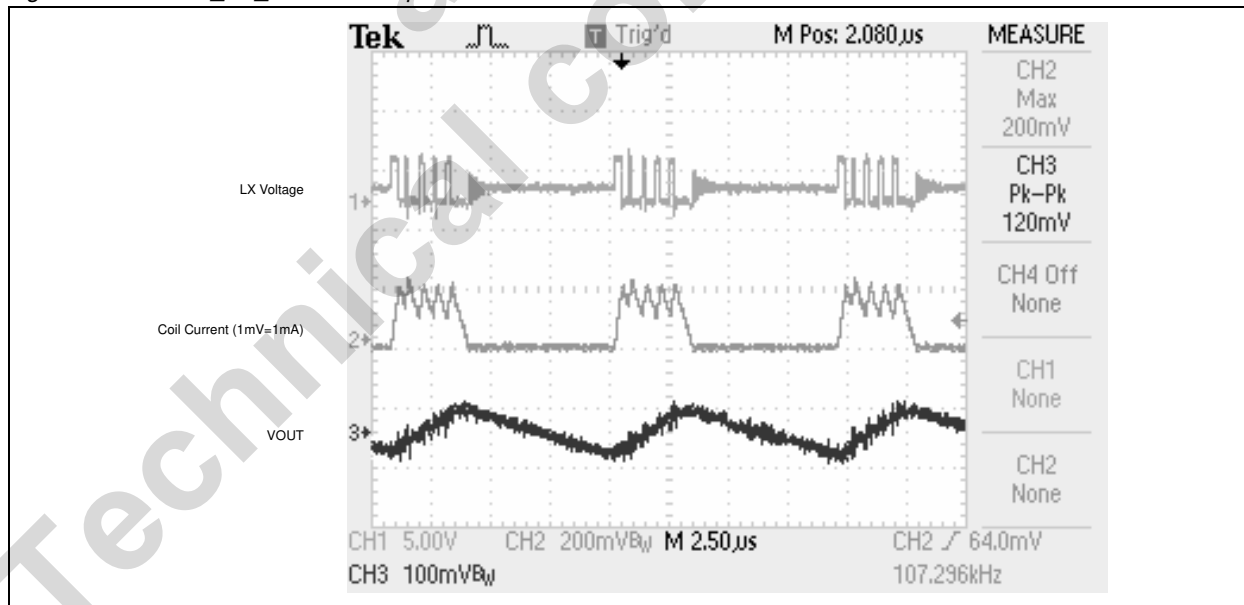

**Note:** It is possible to switch between these two modes during operation, i.e.:

Bit `buck_dis_curmin` = 0: System is in idle state. No audio or RF signal. Decreased supply current preferred. Increase ripple doesn't effect system performance.

Bit **buck\_dis\_curmin** = 1: System is operating. Audio signal on and/or RF signal used. Decreased ripple and noise preferred. Increased power supply current can be tolerated.

### 6.2.3 100% PMOS ON Mode for Low Dropout Regulation

For low input-to-output voltage difference bit **buck\_dis\_pon** (page 29) can be set to allow 100% duty cycle of the PMOS transistor, if the output voltage drops by more than 4% below regulation.

### 6.2.4 Low Power Mode

Bit **buck\_lpo** (page 29) can be set all the time. This mode allows internal power down, of not used blocks during pulskip mode, which results in a better efficiency at light output loads.

ams AG  
Technical content still valid

### 6.2.5 Typical Performance Characteristics

Figure 12. DC/DC Step-Down Efficiency vs. Output Current (Bit buck\_dis\_curmin = 0, Bit buck\_lpo = 0)

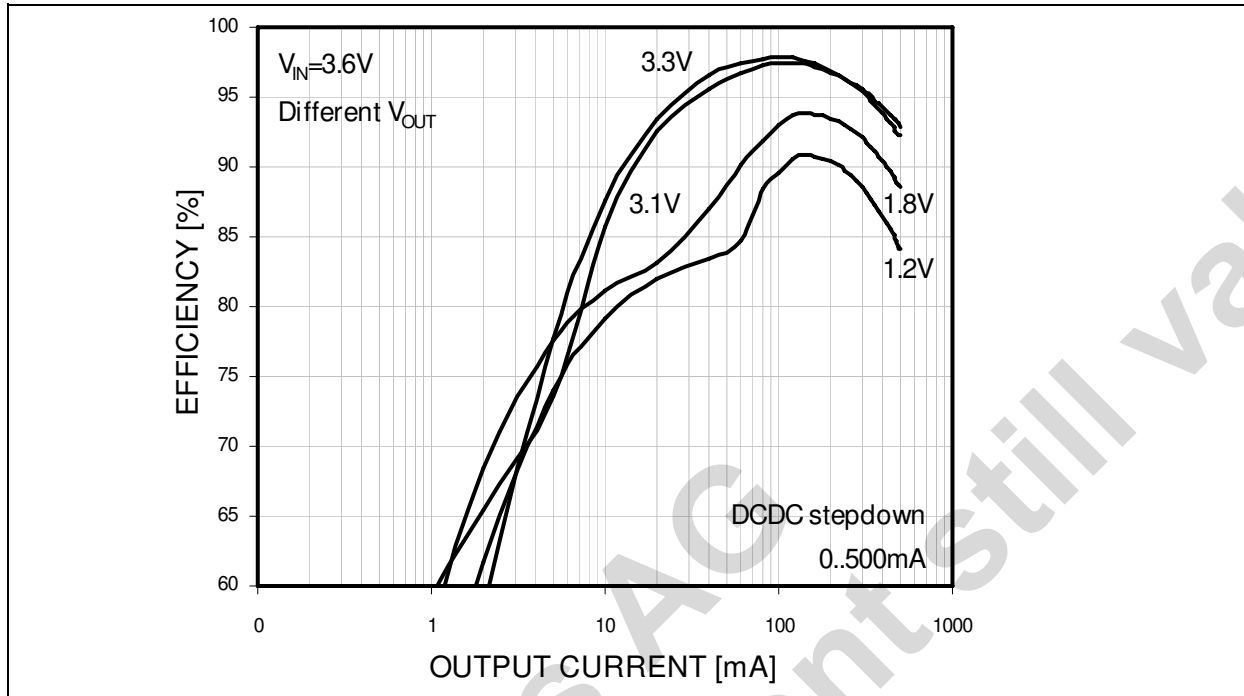

### 6.2.6 Step Down DC/DC Converter Registers

The Step Down DC/DC Converter is controlled by the registers listed in Table 9.

Table 9. Step Down DC/DC Converter Register Summary

Name	Addr	B7	B6	B5	B4	B3	B2	B1	B0	Page
Step Down Voltage/Test Modes Register	01	buck_tm		buck_v						28
Reg Power Control (6ms after start) Register	09	N/A		buck_on	ldo_sim_on	ldo_dig2_on	ldo_dig1_on	ldo_ana2_on	ldo_ana1_on	29
Step Down Configuration Register	23	buck_dis_curmin	buck_dis_pon	buck_lpo	buck_frequ	buck4u7	buck_dis_n	buck_nsw_on	buck_psw_on	29

Addr: 01		Step Down Voltage/Test Modes Register			
		Sets the output voltage of the Step Down DC/DC Converter.			
Bit	Bit Name	Default	Access	Bit Description	
5:0	buck_v	Boot ROM	R/W	Controls the voltage selection for the Step Down DC/DC Converter. 000000 = 0.6V .....(LSB = 50mV) 111000-111111 = 3.4V	
7:6	buck_tm	00	R/W	Buck test mode. Do not use; should be left at 00.	

Addr: 09		Reg Power Control (6ms after start) Register		
Enables/disables voltage regulators.				
Bit	Bit Name	Default	Access	Bit Description
0	ldo_ana1_on			Refer to page 37.
1	ldo_ana2_on			Refer to page 37.
2	ldo_dig1_on			Refer to page 37.
3	ldo_dig2_on			Refer to page 37.
4	ldo_sim_on			Refer to page 37.
5	buck_on	Boot ROM	R/W	Enables the Step Down DC/DC Converter. 0 = Step Down DC/DC Converter is off. 1 = Step Down DC/DC Converter is on.
7:6				N/A

Addr: 23		Step Down Configuration Register		
Configures the operation mode of the Step Down DC/DC Converter.				
Bit	Bit Name	Default	Access	Bit Description
0	buck_psw_on	Boot ROM	R/W	Activate PSW (0.5Ω PMOS) only if <b>buck_on (page 29)</b> and <b>buck_nsw_on (page 29)</b> = 0. 0 = Default setting. P-Channel switching transistor is controlled by the DC/DC Converter. 1 = Turns on P-Channel switching transistor. Bits <b>buck_on</b> and <b>buck_nsw_on</b> must both = 0.
1	buck_nsw_on	Boot ROM	R/W	Activates NSW (0.5Ω NMOS) only if <b>buck_on (page 29)</b> = 0 and <b>buck_psw_on</b> = 0. 0 = Default setting. N-Channel switching transistor is controlled by the DC/DC Converter. 1 = Turns on N-Channel switching transistor. Bits <b>buck_on</b> and <b>buck_psw_on</b> must both = 0.
2	buck_dis_n	Boot ROM	R/W	0 = Default setting. Normal operation of The synchronous rectifier. 1 = The synchronous rectifier is disabled (NSW is always off).
3	buck4u7			0 = 2.2μH inductor 1 = Do not use this setting.
4	buck_frequ	00h	R/W	Selects the step down frequency 0 = 2.2MHz 1 = Do not use this setting.
5	buck_lpo	Boot ROM	R/W	0 = Low-power mode disabled. 1 = Low-power mode enabled.
6	buck_dis_pon	0	R/W	Step down PON feature control. 0 = PON feature enabled. 100% duty cycle (PMOS always on) if output voltage drops more than 4%. Increased output ripple in that operation. 1 = PON feature disabled. Maximum duty cycle = 1 - (tmin_off*fsw)
7	buck_dis_curmin	0	R/W	Step down curmin feature control. 0 = curmin feature enabled. Inductor current regulated to min 170mA. Higher efficiency in low dropout and low output current operation. Higher output ripple and noise. 1 = curmin feature disabled. Decreased efficiency in low dropout mode and at low output current. Small output ripple and noise.

### 6.3 Low Dropout Regulators

The Low Dropout Regulators (LDOs) are linear high performance regulators with programmable output voltages. The LDOs can be controlled by either software (voltage, on/off) or hardware (on/off) using highly configurable GPIO1 to GPIO3 pins.

The Low Dropout Regulators include the following:

- RF and Analog Low Dropout Regulators – Described on page 30
- Digital Low Dropout Regulators – Described on page 31
- SIMCard Low Dropout Regulator – Described on page 32
- Low Power Low Dropout Regulator – Described on page 33

#### 6.3.1 RF and Analog Low Dropout Regulators

The RF LDOs (VRF\_1 - VRF\_4) and Analog LDOs (VANA\_1 and VANA\_2) are designed to supply power to sensitive analog circuits like LNAs, Transceivers, VCOs and other critical RF components of cellular radios. Additionally, these LDOs are suitable for supplying power to audio devices or as a reference for A/D and D/A converters.

The design is optimized to deliver the best compromise between quiescent current and regulator performance for battery powered devices. Stability is guaranteed with ceramic output capacitors (see Figure 13) of  $1\mu\text{F} \pm 20\%$  (X5R) or  $2.2\mu\text{F} +100/-50\%$  (Z5U).

The low ESR of these capacitors ensures low output impedance at high frequencies. Regulation performance is excellent even under low dropout conditions, when the power transistor has to operate in linear mode. Power supply rejection is high enough to suppress ripple on the battery caused by the PA in TDMA systems. The low noise performance allows direct connection of noise sensitive circuits without additional filtering networks. The low impedance of the power transistor enables the device to deliver up to 150mA even at nearly discharged batteries without any decrease of performance.

Figure 13. Analog LDO Block Diagram

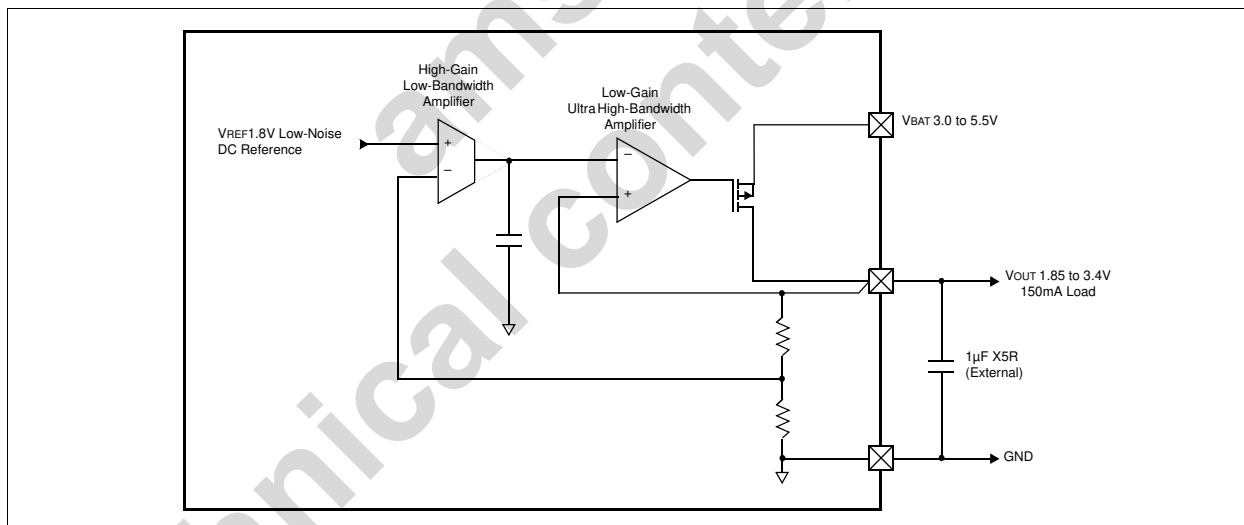

Table 10. RF and Analog LDO Characteristics

$V_{BAT} = 4V$ ;  $I_{LOAD} = 150mA$ ;  $SCSB = 25^{\circ}C$ ;  $C_{LOAD} = 2.2\mu\text{F}$  (Ceramic); unless otherwise specified.

Symbol	Parameter	Min	Typ	Max	Unit	Notes
V <sub>BAT</sub>	Supply Voltage Range	3		5.5	V	
R <sub>ON</sub>	On-Resistance			1	Ω	VANA_1, VANA_2, VRF_1, VRF_2
				2		VRF_3, VRF_4
PSRR	Power Supply Rejection Ratio	70			dB	f = 1kHz
		40				f = 100kHz

Table 10. RF and Analog LDO Characteristics (Continued)

$V_{BAT} = 4V$ ;  $I_{LOAD} = 150mA$ ;  $SCSB = 25^{\circ}C$ ;  $C_{LOAD} = 2.2\mu F$  (Ceramic); unless otherwise specified.

Symbol	Parameter	Min	Typ	Max	Unit	Notes
I <sub>OFF</sub>	Shut Down Current			100	nA	
I <sub>VDD_LDO</sub>	Supply Current			50	$\mu A$	Without load
Noise	Output Noise		30	50	$\mu V_{rms}$	10Hz < f < 100kHz
t <sub>START</sub>	Startup Time			200	$\mu s$	
V <sub>OUT</sub>	Output Voltage	1.85		2.85	V	V <sub>BAT</sub> > 3.0V
		1.85		3.4		Full programmable range
		2.5		3.2		For VANA_1, V <sub>BAT</sub> > 3.0V
V <sub>OUT_TOL</sub>	Output Voltage Tolerance	-50		50	mV	
V <sub>LINEREG</sub>	Line Regulation	-1		1	mV	Static
		-10		10		Transient; Slope: t <sub>r</sub> = 10 $\mu s$
V <sub>LOADREG</sub>	Load Regulation	-1		1	mV	Static
		-10		10		Transient; Slope: t <sub>r</sub> = 10 $\mu s$
I <sub>LIMIT</sub>	Current Limitation		400		mA	VANA_1, VANA_2, VRF_1, VRF_2, VRF_3, VRF_4

### 6.3.2 Digital Low Dropout Regulators

Digital LDOs VD<sub>DIG\_1</sub> and VD<sub>DIG\_2</sub> can be used in any medium-power system or subsystem where quiescent power consumption of the regulator itself needs to be minimized without sacrificing performance.

In order for the Digital LDOs to operate at full range, the Charge Pump (page 41) must be operating to provide adequate gate voltage. This requires that the Charge Pump capacitors C2 and C3 (see Figure 1 on page 2) are installed.

Figure 14. Digital LDO Block Diagram

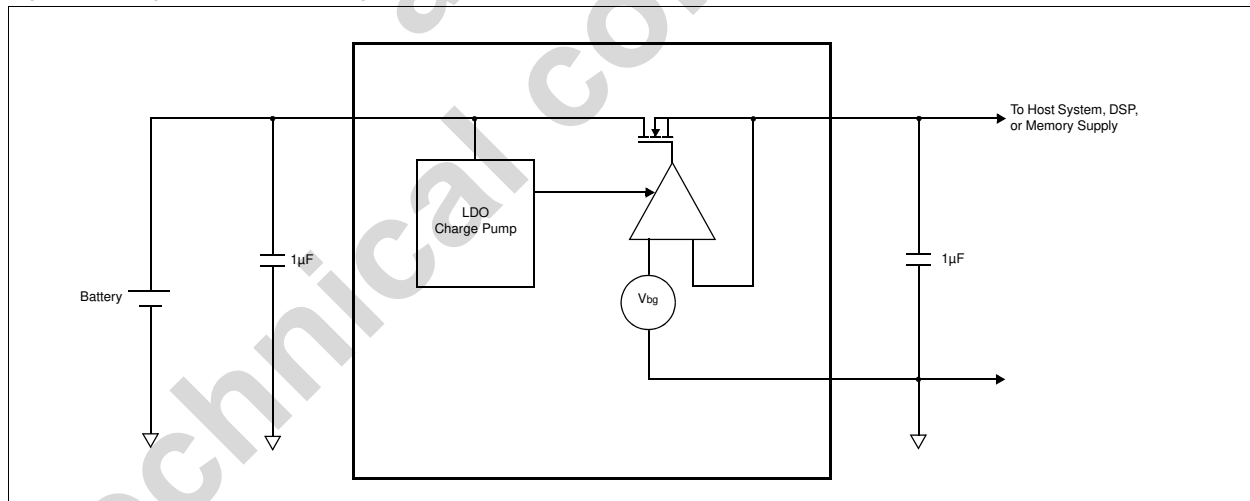

Table 11. Digital LDO Characteristics

$V_{BAT} = 4V$ ;  $I_{LOAD} = 200mA$ ;  $SCSB = 25^{\circ}C$ ;  $C_{LOAD} = 1\mu F$  (Ceramic); unless otherwise specified.

Symbol	Parameter	Min	Typ	Max	Unit	Notes
V <sub>BUCK</sub>	Supply Voltage Range	1		5.5	V	
R <sub>ON</sub>	On-Resistance			4	$\Omega$	



Table 11. Digital LDO Characteristics (Continued)

$V_{BAT} = 4V$ ;  $I_{LOAD} = 200mA$ ;  $SCSB = 25^{\circ}C$ ;  $C_{LOAD} = 1\mu F$  (Ceramic); unless otherwise specified.

Symbol	Parameter	Min	Typ	Max	Unit	Notes
PSRR	Power Supply Rejection Ratio	60				f = 1kHz
		30				f = 100kHz
I <sub>OFF</sub>	Shut Down Current			100	nA	
I <sub>VDD_LDOD</sub>	Supply Current			20	μA	Without load
t <sub>START</sub>	Startup Time			200	μs	
V <sub>OUT</sub>	Output Voltage	.75		1.4	V	$V_{BAT} > 3.0V$ , $V_{5\_6} = 5.2V$ , $I_{LOAD} < 250mA$
		.75		2.2		$V_{BAT} > 3.0V$ , $V_{5\_6} = 5.2V$ , $I_{LOAD} < 200mA$
		.75		2.5		$V_{BAT} > 3.0V$ , $V_{5\_6} = 5.2V$ , $I_{LOAD} < 100mA$
V <sub>OUT_TOL</sub>	Output Voltage Tolerance	-50		50	mV	
V <sub>LINEREG</sub>	Line Regulation	-10		10	mV	Static
		-50		50		Transient; Slope: $t_r = 10\mu s$
V <sub>LOADREG</sub>	Load Regulation	-20		20	mV	Static
		-50		50		Transient; Slope: $t_r = 10\mu s$
I <sub>LIMIT</sub>	Current Limitation		400		mA	

### 6.3.3 SIMCard Low Dropout Regulator

The SIMCard LDO (VSIM) is optimized for SIMCard supply. It is designed to achieve the lowest possible power consumption and still provide reasonable regulation characteristics. To ensure high PSRR and stability, a low-ESR ceramic capacitor of 100nF (min.) must be connected to the output.

Table 12. LDO VSIM Characteristics

$V_{BAT} = 4V$ ;  $I_{LOAD} = 20mA$ ;  $SCSB = 25^{\circ}C$ ;  $C_{LOAD} = 100nF$  (Ceramic); unless otherwise specified.

Symbol	Parameter	Min	Typ	Max	Unit	Notes
V <sub>BAT</sub>	Supply Voltage Range	3		5.5	V	
R <sub>ON</sub>	On-Resistance			50	Ω	
PSRR	Power Supply Rejection Ratio	40			dB	f = 1kHz
		20				f = 100kHz
I <sub>OFF</sub>	Shut Down Current			100	nA	
I <sub>VDD_SIMCARD</sub>	Supply Current		40		μA	
t <sub>START</sub>	Startup Time			200	μs	
V <sub>OUT</sub>	Output Voltage	1.8		3.0	V	$V_{BAT} > 3.2V$
V <sub>OUT_TOL</sub>	Output Voltage Tolerance	-50		50	mV	
V <sub>LINEREG</sub>	Line Regulation	-10		10	mV	Static
		-100		100		Transient; Slope: $t_r = 10\mu s$
V <sub>LOADREG</sub>	Load Regulation	-10		10	mV	Static
		-100		100		Transient; Slope: $t_r = 10\mu s$

### 6.3.4 Low Power Low Dropout Regulator

The low-power bootstrap LDO (V2\_5) is needed to supply power to the core (analog and digital) of the AS3604. LDO V2\_5 is designed to achieve the lowest possible power consumption, and still provide reasonable regulation characteristics. LDO V2\_5 has two supply inputs selecting automatically the higher one. This gives the possibility to supply the AS3604 core either with the battery or with the Battery Charger, depending on the conditions.

To ensure high PSRR and stability, a low-ESR ceramic capacitor of 1 $\mu$ F (min.) must be connected to the output.

**Note:** Levelshifters in both directions (input and output) are placed between digital pins (VANA\_1) and the digital core (V2\_5) of the device, because of the different power supplies.

Table 13. LDO V2\_5 Characteristics

V<sub>BAT</sub> = 4V; C<sub>LOAD\_EXT</sub> = 0; SCSB = 25°C; C<sub>LOAD</sub> = 2.2 $\mu$ F (Ceramic); unless otherwise specified.

Symbol	Parameter	Min	Typ	Max	Unit	Notes
V <sub>BAT</sub>	Supply Voltage Range	2.8		5.5	V	
V <sub>CHARGER</sub>	External Charger Adapter voltage	4		15	V	
R <sub>ON</sub>	On-Resistance			50	$\Omega$	Guaranteed per design
PSRR	Power Supply Rejection Ratio	60			dB	f = 1kHz
		40				f = 100kHz
I <sub>OFF</sub>	Shut Down Current			100	nA	
I <sub>VDD_LPLDO</sub>	Supply Current			3	$\mu$ A	Guaranteed per design; consider device internal load for measurement
t <sub>START</sub>	Startup Time			200	$\mu$ s	
V <sub>OUT</sub>	Output Voltage	2.4	2.5	2.6	V	
V <sub>OUT_TOL</sub>	Output Voltage Tolerance	-50		50	mV	
V <sub>LINE</sub> REG	Line Regulation	-10		10	mV	Static
		-50		50		Transient; Slope: t <sub>r</sub> = 10 $\mu$ s
V <sub>LOAD</sub> REG	Load Regulation	-10		10	mV	Static
		-50		50		Transient; Slope: t <sub>r</sub> = 10 $\mu$ s

### 6.3.5 Typical Performance Characteristics

Figure 15. Load Regulation of LDOs VANA\_1, VANA\_2, VRF\_1, VRF\_2

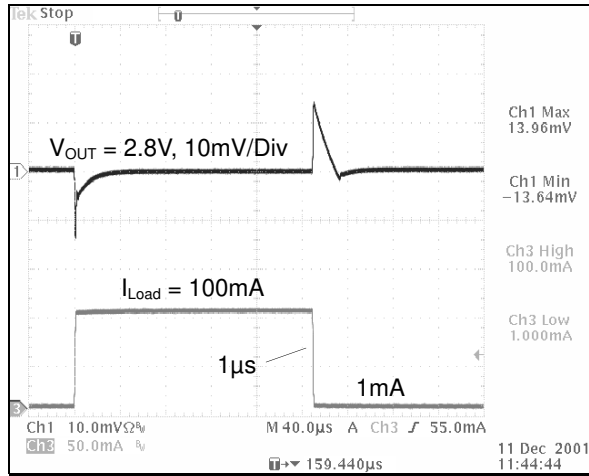

X-Axis: 40µs/Div

Figure 17. Load Regulation of LDOs VDIG\_1, VDIG\_2

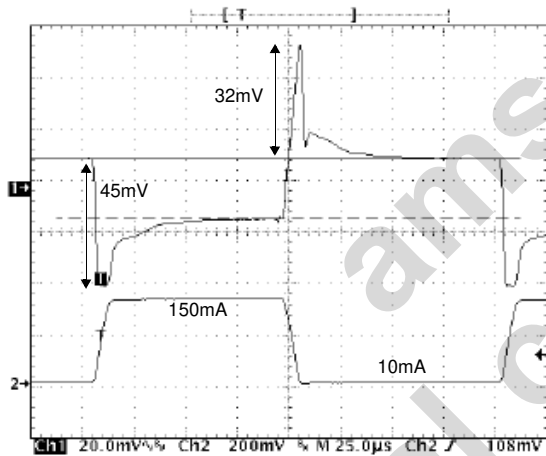

X-Axis: 25µs/Div

Figure 18. Line Regulation of LDOs VANA\_1, VANA\_2, VRF\_1, VRF\_2

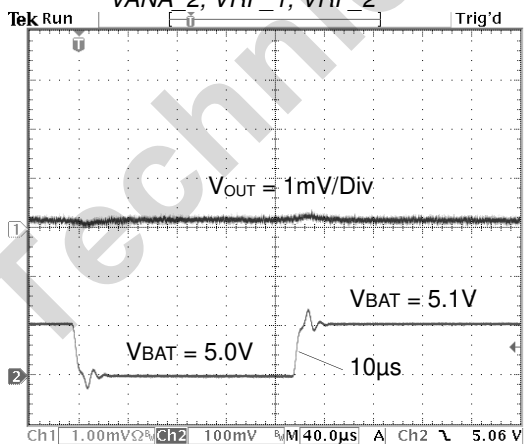

X-Axis: 40µs/Div

Figure 16. Output Noise of LDOs VANA\_1, VANA\_2, VRF\_1, VRF\_2

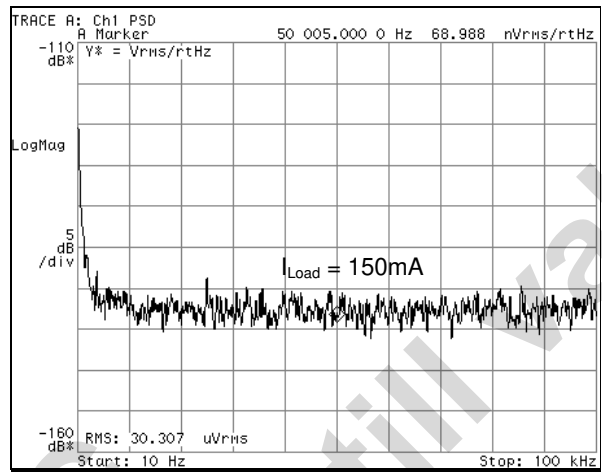

Spectral Distribution at 150mA Output Load

Figure 17. Load Regulation of LDO V2\_5

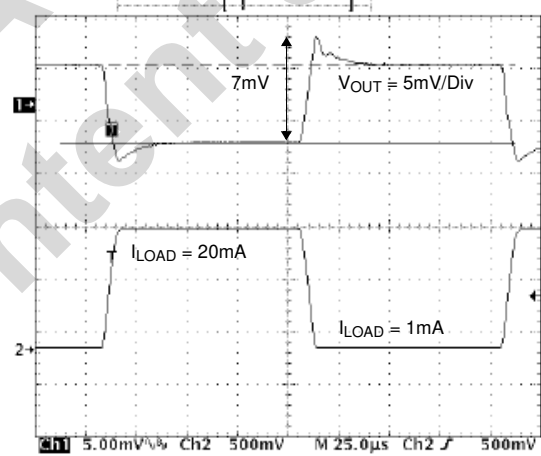

X-Axis: 25µs/Div

Figure 19. Line Regulation of LDOs VANA\_1, VANA\_2, VRF\_1, VRF\_2

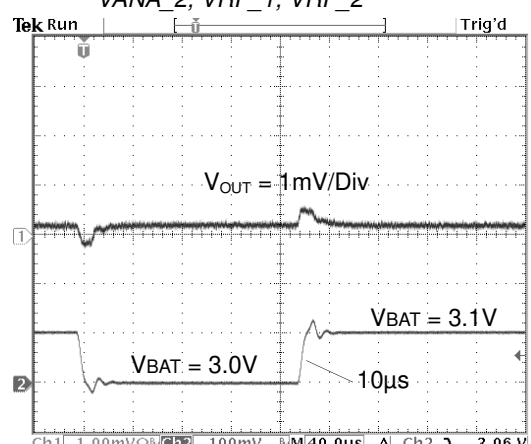

X-Axis: 40µs/Div

### 6.3.6 LDO Registers

The Low Dropout Regulators are controlled by the registers listed in Table 14.

Table 14. Low Dropout Regulators Register Summary

Name	Addr	B7	B6	B5	B4	B3	B2	B1	B0	Page
LDO_RF1 Voltage Register	2	N/A			ldo_rf1_v					35
LDO_RF2 Voltage Register	3	N/A			ldo_rf2_v					35
LDO_RF3 Voltage Register	4	N/A			ldo_rf3_v					35
LDO_RF4 Voltage Register	5	N/A			ldo_rf4_v					35
LDO_ANA Voltage Register	6	ldo_ana1_v			ldo_ana2_v					36
LDO_DIG1 Voltage Register	7	N/A		ldo_dig1_v						36
LDO_DIG2 Voltage Register	8	N/A	ldo_sim_v	ldo_dig2_v						36
Reg Power Control (6ms after start) Register	9	N/A		buck_on	ldo_sim_on	ldo_dig2_on	ldo_dig1_on	ldo_ana2_on	ldo_ana1_on	37
LDO_GPIO Active Register	15	ldo_dig2_gpio	ldo_dig1_gpio	ldo_rf4_gpio	ldo_rf3_gpio	ldo_rf2_gpio	ldo_rf1_gpio	ldo_ana2_gpio	ldo_buck_gpio	39
LDO_RF Switch Register	16	ldo_rf4_on	ldo_rf3_on	ldo_rf2_on	ldo_rf1_on	rf4_sw	rf3_sw	ana2_sw	ana1_sw	38
LDO_AD GPIO Register	17	ldo_dig2_gpio_sel		ldo_dig1_gpio_sel		ldo_ana2_gpio_sel		ldo_buck_gpio_sel		39
LDO_RF GPIO Register	18	ldo_rf4_gpio_sel		ldo_rf3_gpio_sel		ldo_rf2_gpio_sel		ldo_rf1_gpio_sel		40

Addr: 02		LDO_RF1 Voltage Register			
		Sets the voltage for LDO VRF_1.			
Bit	Bit Name	Default	Access	Bit Description	
4:0	ldo_rf1_v	Boot ROM	R/W	00000 = 1.85V ... (LSB = 50mV) 11111 = 3.40V	
7:5				N/A	

Addr: 03		LDO_RF2 Voltage Register			
		Sets the voltage for LDO VRF_2.			
Bit	Bit Name	Default	Access	Bit Description	
4:0	ldo_rf2_v	Boot ROM	R/W	00000 = 1.85V ... (LSB = 50mV) 11111 = 3.40V	
7:5				N/A	

Addr: 04		LDO_RF3 Voltage Register			
		Sets the voltage for LDO VRF_3.			
Bit	Bit Name	Default	Access	Bit Description	
4:0	ldo_rf3_v	Boot ROM	R/W	00000 = 1.85V ... (LSB = 50mV) 11111 = 3.40V	
7:5				N/A	

Addr: 05		LDO_RF4 Voltage Register			
		Sets the voltage for LDO VRF_4.			
Bit	Bit Name	Default	Access	Bit Description	
4:0	ldo_rf4_v	Boot ROM	R/W	00000 = 1.85V ... (LSB = 50mV) 11111 = 3.40V	
7:5				N/A	

Addr: 06		LDO_ANA Voltage Register		
Sets the voltage for LDOs VANA_1 and VANA_2.				
Bit	Bit Name	Default	Access	Bit Description
4:0	ldo_ana2_v	Boot ROM	R/W	Sets the voltage for LDO VANA_2. 00000 = 1.85V ... (LSB = 50mV) 11111 = 3.40V
7:5	ldo_ana1_v	Boot ROM	R/W	Sets the voltage for LDO VANA_1. 000 = 2.5V ... (LSB = 100mV) 111 = 3.2V

Addr: 07		LDO_DIG1 Voltage Register		
Sets the voltage for Digital LDO VDIG_1.				
Bit	Bit Name	Default	Access	Bit Description
5:0	ldo_dig1_v	Boot ROM	R/W	Table 15 lists the Digital LDO programmable voltages.
7:6				N/A

Addr: 08		LDO_DIG2 Voltage Register		
Sets the voltage for Digital LDOs VDIG_2 and VSIM.				
Bit	Bit Name	Default	Access	Bit Description
5:0	ldo_dig2_v	Boot ROM	R/W	Sets the voltage for Digital LDO VDIG_2. Table 15 lists the Digital LDO programmable voltages.
6	ldo_sim_v	Boot ROM	R/W	Sets the voltage for LDO VSIM. 0 = 1.8V 1 = 3.0V (default)
7				N/A

Table 15. Digital LDOs VDIG\_1 and VDIG\_2 Programming Voltage

Decimal Code	Binary Code	V <sub>out</sub> [V]	Decimal Code	Binary Code	V <sub>out</sub> [V]
0	000000	0.75	22	010110	1.80
1	000001	0.80	23	010111	1.80
2	000010	0.85	24	011000	1.80
3	000011	0.90	25	011001	1.80
4	000100	0.95	26	011010	1.80
5	000101	1.00	27	011011	1.80
6	000110	1.05	28	011100	1.80
7	000111	1.10	29	011101	1.80
8	001000	1.15	30	011110	1.80
9	001001	1.20	31	011111	1.80
10	001010	1.25	32	100000	1.50
11	001011	1.30	33	100001	1.60
12	001100	1.35	34	100010	1.70
13	001101	1.40	35	100011	1.80
14	001110	1.45	36	100100	1.90
15	001111	1.50	37	100101	2.00
16	010000	1.55	38	100110	2.10
17	010001	1.60	39	100111	2.20
18	010010	1.65	40	101000	2.30
19	010011	1.70	41	101001	2.40

Table 15. Digital LDOs VDIG\_1 and VDIG\_2 Programming Voltage (Continued)

Decimal Code	Binary Code	V <sub>out</sub> [V]	Decimal Code	Binary Code	V <sub>out</sub> [V]
20	010100	1.75	42	101010	2.50
21	010101	1.80	-	-	-

**Note:** Full performance for V<sub>out</sub> ≤ 2.20V (max.), 100mA output current for V<sub>out</sub> ≤ 2.50V.

**Caution:** Do not use values for V<sub>OUT</sub> > 2.50V.

Addr: 09		Reg Power Control (6ms after start) Register			
		Enables/disables voltage regulators.			
Bit	Bit Name	Default	Access	Bit Description	
0	ldo_ana1_on	Boot ROM	R/W	Enables control of LDO VANA_1. 0 = LDO VANA_1 is off. 1 = LDO VANA_1 is on. <b>Note:</b> Do not set this bit = 0 or serial interface access will be disabled.	
1	ldo_ana2_on	Boot ROM	R/W	Enables control of LDO VANA_2. 0 = LDO VANA_2 is off. 1 = LDO VANA_2 is on.	
2	ldo_dig1_on	Boot ROM	R/W	Enables control of LDO VDIG_1. 0 = LDO VDIG_1 is off. 1 = LDO VDIG_1 is on.	
3	ldo_dig2_on	Boot ROM	R/W	Enables control of LDO VDIG_2. 0 = LDO VDIG_2 is off. 1 = LDO VDIG_2 is on.	
4	ldo_sim_on	Boot ROM	R/W	Enables control of LDO VSIM. 0 = LDO VSIM is off. 1 = LDO VSIM is on.	
5	buck_on			Refer to page 29.	
7:6				N/A	

Addr: 16		LDO_RF Switch Register		
Enables LDOs as high-side switches.				
Bit	Bit Name	Default	Access	Bit Description
0	ana1_sw	Boot ROM	R/W	0 = VANA_1 operates as LDO. 1 = VANA_1 is operating as high-side switch ( $R_{on} = 1\Omega$ ); valid if <b>ldo_rf1_on</b> = 0.
1	ana2_sw	Boot ROM	R/W	0 = VANA_2 operates as LDO. 1 = VANA_2 is operating as high-side switch ( $R_{on} = 1\Omega$ ); valid if <b>ldo_rf2_on</b> = 0.
2	rf3_sw	Boot ROM	R/W	0 = VRF_3 operates as LDO. 1 = LDO VRF_3 is operating as high-side switch ( $R_{on} = 2\Omega$ ); valid if <b>ldo_rf3_on</b> = 0.
3	rf4_sw	Boot ROM	R/W	0 = VRF_4 operates as LDO. 1 = LDO VRF_4 is operating as high-side switch ( $R_{on} = 2\Omega$ ); valid if <b>ldo_rf4_on</b> = 0.
4	ldo_rf1_on	Boot ROM	R/W	Enables control of LDO VRF_1. Set <b>ana1_sw</b> = 0 before setting this bit = 1. 0 = LDO VRF_1 is off. 1 = LDO VRF_1 is on.
5	ldo_rf2_on	Boot ROM	R/W	Enables control of LDO VRF_2. Set <b>ana2_sw</b> = 0 before setting this bit = 1. 0 = LDO VRF_2 is off. 1 = LDO VRF_2 is on.
6	ldo_rf3_on	Boot ROM	R/W	Enables control of LDO VRF_3. Set <b>rf3_sw</b> = 0 before setting this bit = 1. 0 = LDO VRF_3 is off. 1 = LDO VRF_3 is on.
7	ldo_rf4_on	Boot ROM	R/W	Enables control of LDO VRF_4. Set <b>rf4_sw</b> = 0 before setting this bit = 1. 0 = LDO VRF_4 is off. 1 = LDO VRF_4 is on.

ldo_rfx_on*	rfx:sw*	RF LDO Function
0	0	Off
0	1	Fully On, $R_{ON} = 1$ or $2\Omega$
1	0	Linear Voltage Regulator
1	1	Not Allowed

\* Where  $x = 1-4$

Addr: 15		LDO_GPIO Active Register		
Activates GPIO on/off control for voltage regulators.				
Bit	Bit Name	Default	Access	Bit Description
0	buck_gpio	Boot ROM	R/W	Activates GPIO control of Step Down DC/DC Converter. 0 = Controlled by software. 1 = On when assigned GPIO pin = 1 and bit <b>buck_on</b> (page 29) = 1.
1	ldo_ana2_gpio	Boot ROM	R/W	Activates GPIO control for LDO VANA_2. 0 = Controlled by software. 1 = On when assigned GPIO pin = 1 and bit <b>ldo_ana2_on</b> (page 37) = 1.
2	ldo_rf1_gpio	Boot ROM	R/W	Activates GPIO control for LDO VRF_1. 0 = Controlled by software. 1 = On when assigned GPIO pin = 1 and bit <b>ldo_rf1_on</b> (page 38) = 1.
3	ldo_rf2_gpio	Boot ROM	R/W	Activates GPIO control for LDO VRF_2. 0 = Controlled by software. 1 = On when assigned GPIO pin = 1 and bit <b>ldo_rf2_on</b> (page 38) = 1.
4	ldo_rf3_gpio	Boot ROM	R/W	Activates GPIO control for LDO VRF_3. 0 = Controlled by software. 0 = On when assigned GPIO pin = 1 and bit <b>ldo_rf3_on</b> (page 38) = 1.
5	ldo_rf4_gpio	Boot ROM	R/W	Activates GPIO control for LDO VRF_4. 0 = Controlled by software. 1 = LDO VRF_4 is on when assigned GPIO pin = 1 and bit <b>ldo_rf4_on</b> (page 38) = 1.
6	ldo_dig1_gpio	Boot ROM	R/W	Activates GPIO control for LDO VDIG_1. 0 = Controlled by software. 1 = On when assigned GPIO pin = 1 and bit <b>ldo_dig1_on</b> (page 37) = 1.
7	ldo_dig2_gpio	Boot ROM	R/W	Activates GPIO control for LDO VDIG_2. 0 = Controlled by software. 1 = On when assigned GPIO pin = 1 and bit <b>ldo_dig2_on</b> (page 37) = 1.

Addr: 17		LDO_AD GPIO Register		
Selects GPIO pin for power on/off control.				
Bit	Bit Name	Default	Access	Bit Description
1:0	buck_gpio_sel	Boot ROM	R/W	Valid if GPIO activation bit <b>buck_gpio</b> (page 39) = 1. 00 = GPIO1 01 = GPIO2 – this setting cannot be selected when GPIO2 is used as feedback pin. 10 = GPIO3 11 = Do not use this setting.
3:2	ldo_ana2_gpio_sel	Boot ROM	R/W	Valid if GPIO activation bit <b>ldo_ana2_gpio</b> (page 39) = 1. 00 = GPIO1 01 = GPIO2 10 = GPIO3 11 = Do not use this setting.
5:4	ldo_dig1_gpio_sel	Boot ROM	R/W	Valid if GPIO-activation bit <b>ldo_dig1_gpio</b> (page 39) = 1. 00 = GPIO1 01 = GPIO2 10 = GPIO3 11 = Do not use this setting.
7:6	ldo_dig2_gpio_sel	Boot ROM	R/W	Valid if GPIO-activation bit <b>ldo_dig2_gpio</b> (page 39) = 1. 00 = GPIO1 01 = GPIO2 10 = GPIO3 11 = Do not use this setting.



Addr: 18		LDO_RF GPIO Register		
Selects GPIO pin for power on/off control for RF LDOs VRF_1 - VRF_4.				
Bit	Bit Name	Default	Access	Bit Description
1:0	ldo_rf1_gpio_sel	Boot ROM	R/W	Valid if <b>ldo_rf1_gpio (page 39) = 1</b> . 00 = GPIO1 01 = GPIO2 10 = GPIO3 11 = Do not use this setting.
3:2	ldo_rf2_gpio_sel	Boot ROM	R/W	Valid if <b>ldo_rf2_gpio (page 39) = 1</b> . 00 = GPIO1 01 = GPIO2 10 = GPIO3 11 = Do not use this setting.
5:4	ldo_rf3_gpio_sel	Boot ROM	R/W	Valid if <b>ldo_rf3_gpio (page 39) = 1</b> . 00 = GPIO1 01 = GPIO2 10 = GPIO3 11 = Do not use this setting.
7:6	ldo_rf4_gpio_sel	Boot ROM	R/W	Valid if <b>ldo_rf4_gpio (page 39) = 1</b> . 00 = GPIO1 01 = GPIO2 10 = GPIO3 11 = Do not use this setting.

## 6.4 Charge Pump

The Charge Pump uses VANA\_1 (supplied by Analog LDO VANA\_1) as input and doubles this voltage using a flying capacitor between pins CAPP and CAPN (see Figure 1 on page 2) to its output, V5\_6. If bit **cp\_pulseskip** (page 41) is set, the Charge Pump compares its output voltage against a voltage reference, defined by **cp\_vref** (page 41), and only starts charging cycles if its output voltage is below **cp\_vref**. If V5\_6 is > 5.6V (when VANA\_1 is >2.8V), pulseskip will automatically be enabled (depending on bit **cp\_vref**) to protect the pin from overvoltage (bit **cp\_pulseskip** will not be set in this case).

The Charge Pump requires the external components specified in Table 16.

Table 16. Charge Pump External Components

Symbol	Parameter	Min	Typ	Max	Unit	Notes
CFLY (C2)	External Flying Capacitor		330		nF	Ceramic low-ESR capacitor between pins CAPP and CAPN (page 2).
CSTORE (C3)	External Storage Capacitor	1		4.7	μF	Ceramic low-ESR capacitor between pins V5_6 and VSS (page 2).

**Note:** Connections to the two external capacitors should be kept as short as possible.

Table 17. Charge Pump Parameters

Symbol	Parameter	Min	Typ	Max	Unit	Notes
ICPOUT	Output Current	0		30	mA	VANA_1 = 2.8V, internal clock selected, <b>cp_vref</b> (page 41) = 5.25V or <b>cp_pulseskip</b> = 0.
VCPOUT	Output Voltage	5.0	5.2	5.6	V	
VCPOUT10	Output Voltage (No Load)	2 x VANA_1				VANA_1 ≥ 2.0V, no load at output, <b>cp_pulseskip</b> = 0.
IQUIESCENT	Quiescent Current		980		μA	<b>cp_pulseskip</b> = 0, <b>cp_freq</b> (page 41) = 0 (1.1MHz).
			498			<b>cp_pulseskip</b> = 0, <b>cp_freq</b> = 1 (550kHz).
			5			<b>cp_pulseskip</b> = 1, <b>cp_freq</b> = 0, VANA_1 = 2.8V.
			4			<b>cp_pulseskip</b> = 1, <b>cp_freq</b> = 1, VANA_1 = 2.8V.
ISHUTDOWN	Shutdown Current			0.1	μA	@25°C
VRIPPLE	Ripple Voltage		28.8		mVp-p	<b>cp_pulseskip</b> = 0, <b>cp_freq</b> = 0, ILOAD = 30mA.

### 6.4.1 Charge Pump Control Register

Addr: 24		Charge Pump Control Register		
Sets the operation mode of the Charge Pump.				
Bit	Bit Name	Default	Access	Bit Description
0	cp_on	Boot ROM	R/W	0 = Charge Pump is off. 1 = Activates the Charge Pump. The Charge Pump is automatically activated when any of the following blocks are active: Audio Amplifier, VDIG_1, VDIG_2.
1	cp_pulseskip	Boot ROM	R/W	Controls the Charge Pump pulseskip mode. 0 = Always try to double the voltage on VANA_1. 1 = Only start a cycle if V5_6 is lower than the voltage defined by bit <b>cp_vref</b> .
2	cp_vref	Boot ROM	R/W	If in pulseskip mode, regulate to the following voltage by leaving out complete cycles: 0 = 4.74V 1 = 5.25V
3				N/A
4	cp_freq	Boot ROM	R/W	Sets the Charge Pump clock frequency. 0 = System clock 1 = System clock/2 (half frequency)
5	onkey_pulldown			Controls the pulldown on pin ON. 0 = Switches on the pulldown on pin ON. 1 = Switches off the pulldown on pin ON.
7:6				N/A

## 6.5 Step Up DC/DC Converter

The integrated Step Up DC/DC Converter is a high-efficiency current-mode PWM regulator, providing an output voltage of up to 15V. A constant switching-frequency results in low noise on supply and output voltages. An optional digital NMOS switch is provided for cases when the Step Up DC/DC Converter is not used.

Figure 20. Step Up DC/DC Converter Block Diagram

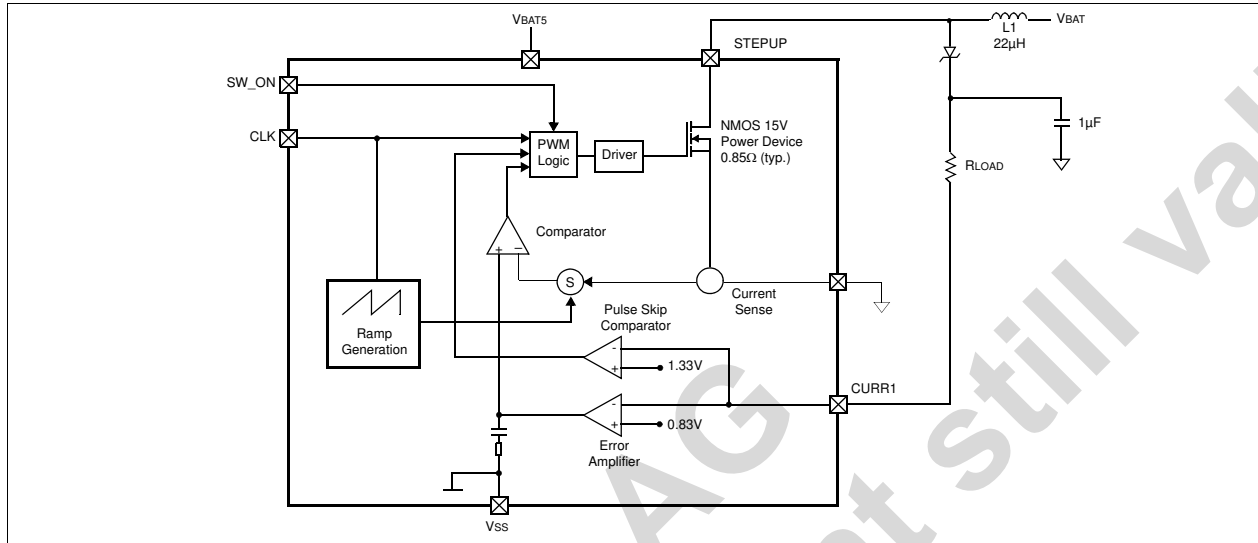

Table 18. Step Up DC/DC Converter Parameters

Symbol	Parameter	Min	Typ	Max	Unit	Notes
V <sub>SW</sub>	High Voltage Pin	0		15	V	Pin STEPUP
I <sub>VDD_SU</sub>	Quiescent Current		140		μA	Pulse skipping mode
I <sub>SHUTDOWN</sub>	Shutdown Current			100	nA	@25°C
V <sub>FB</sub>	Feedback Voltage, Transient	0		5.5	V	Pin CURR1
V <sub>FB</sub>	Feedback Voltage during Regulation	0.65	0.83	1.0	V	Pin CURR1
I <sub>SW_max</sub>	Current Limit	550	780	1100	mA	<b>stpup_on</b> (page 43) = 1 <b>stpup_low_curr</b> (page 43) = 0
		350	510	750	mA	<b>stpup_on</b> = 1, <b>stpup_low_curr</b> = 1
R <sub>SW</sub>	Switch Resistance		0.85	1.54	Ω	<b>stpup_on</b> = 0, <b>stpup_low_curr</b> = 1
I <sub>LOAD</sub>	Load Current	0		45	mA	At 15V output voltage.
V <sub>PULSESKIP</sub>	Pulseskip Threshold	1.2	1.33	1.5	V	PIN CURR1. <b>Note:</b> Voltage at pin CURR1, pulse skips are introduced when load current becomes too low.
V <sub>RIPPLE</sub>	Ripple Voltage		146		mVp-p	<b>stpup_freq</b> (page 43) = 0, V <sub>OUT</sub> = 15V, I <sub>LOAD</sub> = 45mA, BW ≤ 20MHz.
f <sub>IN</sub>	Fixed Switching Frequency	1	1.1	1.2	MHz	1.1MHz; <b>stpup_freq</b> = 0
		0.5	0.55	0.6		0.55MHz; <b>stpup_freq</b> = 1
C <sub>OUT</sub>	Output Capacitor		1		μF	Ceramic
L (Inductor)	I <sub>LOAD</sub> > 20mA	17	22	27	μH	Use inductors with small C <sub>PARASITIC</sub> (<100pF) for high efficiency.
	I <sub>LOAD</sub> < 20mA	8	10	27		
t <sub>MIN_ON</sub>	Minimum On-Time	90		180	ns	
MDC	Maximum Duty Cycle	88	91	94	%	Guaranteed per design.

### 6.5.1 Step Up DC/DC Converter Register

Addr: 25		Step Up DC/DC Converter Control Register		
Sets the operation mode of the Step Up DC/DC Converter.				
Bit	Bit Name	Default	Access	Bit Description
0	stpup_on	Boot ROM	R/W	Activates the Step Up DC/DC Converter. 0 = Step Up DC/DC Converter is off. 1 = Step Up DC/DC Converter is on.
1	stpup_sw_on	Boot ROM	R/W	This bit controls the NMOS switch on pin STEPUP only if <b>stpup_on</b> = 0. 0 = Switch open (STEPUP floating). 1 = Switch closed (STEPUP pulled to VSS).
2	stpup_freq	Boot ROM	R/W	Defines the clock frequency of the Step Up DC/DC Converter. 0 = System clock (typ. 1.1MHz). 1 = System clock/2 (half frequency).
3	stpup_low_curr	Boot ROM	R/W	NMOS-switch current-limit control only if <b>stpup_on</b> = 1. 0 = High current limit (600mA). 1 = Low current limit (300mA).
7:4				N/A

Figure 21. Typical Performance Characteristics

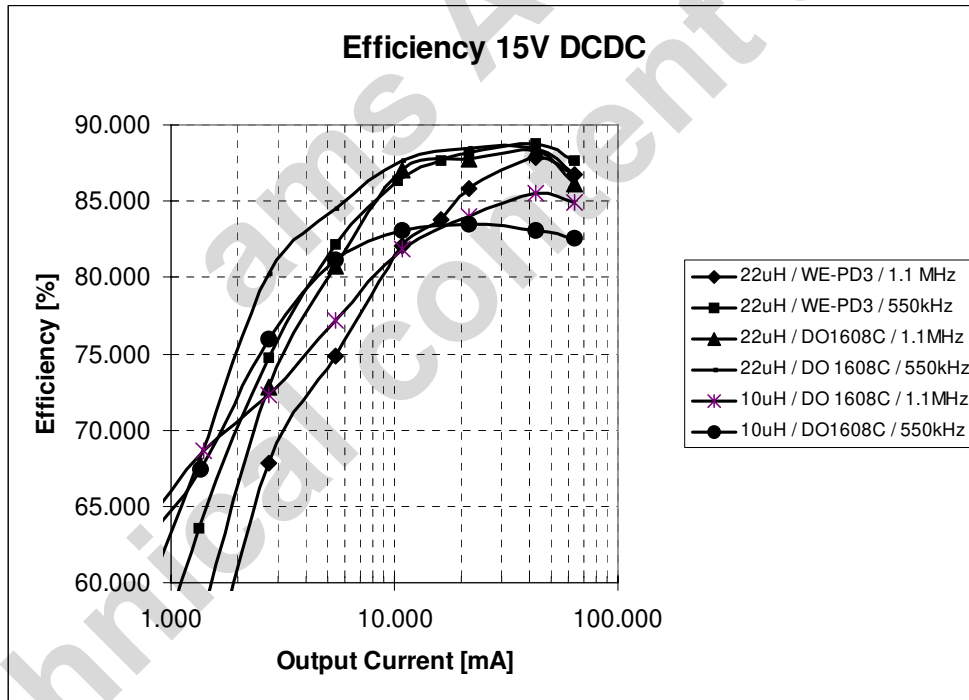

## 6.6 General Purpose Input/Output

The general purpose input/output pins (GPIO1 - GPIO3) are highly configurable and independently controlled.

Table 19. DC Characteristics Input/Output Pin with Selectable Supply GPIO1:GPIO3

Parameter	Symbol	Min	Max	Unit	Notes
High-Level Input Voltage	V <sub>IH</sub>	0.7 x VANA_1		V	
Low-Level Input Voltage	V <sub>IL</sub>		0.3 x VANA_1	V	
Hysteresis	V <sub>HYS</sub>	0.2 x VANA_1		V	
Input Leakage Current (if not used as pulldown/pullup)	I <sub>LEAK</sub>	-5	5	μA	to VANA_1 and VSS
Pulldown Current (if configured as pulldown)	I <sub>PULLDOWN</sub>	5	50	μA	to VSS
Pullup Current (if configured as pullup)	I <sub>PULLUP</sub>	-200	-20	μA	to V5_6 or VANA_1 as configured
High-Level Output Voltage Supply VANA_1	V <sub>OH</sub>	0.8 x VANA_1		V	at -2mA
High-Level Output Voltage Supply V5_6 (V5_6 min. 5.0V)	V <sub>OHV</sub>	0.8 x V5_6		V	at -2mA
Low-Level Output Voltage	V <sub>OL</sub>		0.2 x VANA_1	V	at 2mA
Capacitive Load	C <sub>LOAD</sub>		50	pF	

GPIO1 - GPIO3 can be used to accommodate the following functionality:

- Software controlled input and output
- Input pin for the Watchdog
- Signal input (GPIO1-GPIO3)
- Interrupt output with configurable interrupt source
- Configurable frequency and duty cycle output
- External clock input for Step Up/Down DC/DC Converters and Charge Pump synchronization (GPIO1 only)
- Active pullup or pulldown; can be combined with other I/O functions
- Output open drain (push or pull type)
- Output high-level voltage selection between V5\_6 or VANA\_1; (V5\_6 not possible on GPIO2)
- Optional feedback input for Step Down DC/DC Converter (GPIO2)

Figure 22. General Purpose I/O Block Diagram

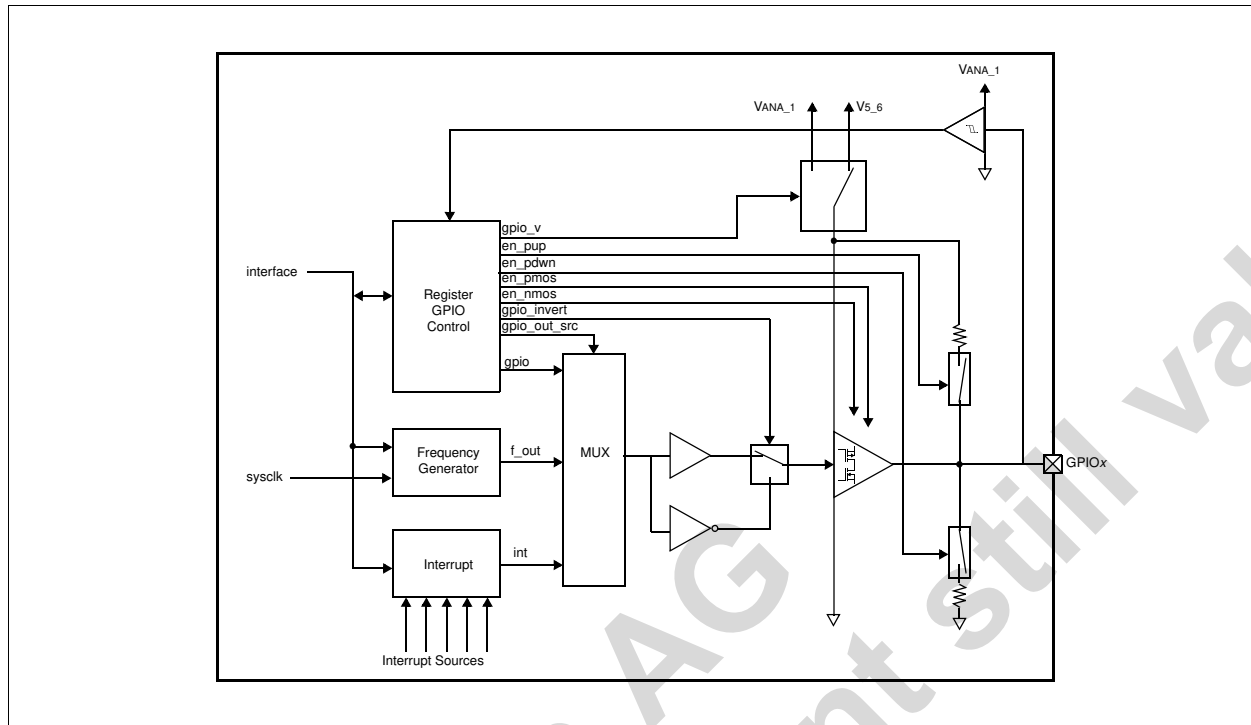

### 6.6.1 GPIO Registers

GPIO1 - GPIO3 are controlled by the registers listed in Table 20.

Table 20. GPIO Register Summary

Name	Addr	B7	B6	B5	B4	B3	B2	B1	B0	Page	
GPIO1 Control Register	26	gpio1_out_src		gpio1_invert		gpio1_pulls	gpio1_voltage		gpio1_mode	46	
GPIO2 Control Register	27	gpio2_out_src		gpio2_invert		gpio2_pulls	stepdown_fb		gpio2_mode	46	
GPIO3 Control Register	28	gpio3_out_src		gpio3_invert		gpio3_pulls	gpio3_voltage		gpio3_mode	47	
GPIO Signal Register	33	N/A					gpio3	gpio2	gpio1		47
GPIO Frequency Control High Time Register	34	gpio_h_time									48
GPIO Frequency Control Low Time Register	35	gpio_l_time									48
Clock Generation Register	30	N/A							ext_clk		48
Interrupt Enable Register	31	chgov_int_en	chgrmv_int_en	resume_int_en	chdet_int_en	onkey_int_en	ovtmp_int_en	vchoff_int_en	wdog_int_en	49	
Interrupt Status Register	32	chgov_i	chgrmv_i	resume_i	chdet_i	onkey_i	ovtmp_i	vchoff_i	wdog_i	49	

Addr: 26		GPIO1 Control Register		
Configures pin GPIO1.				
Bit	Bit Name	Default	Access	Bit Description
1:0	gpio1_mode	Boot ROM	R/W	Sets the direction for pin GPIO1. 00 = Input only. 01 = Output (push and pull). 10 = Output (open drain, only push; only NMOS is active). 11 = Output (open drain, only pull; only PMOS is active).
2	gpio1_voltage	Boot ROM	R/W	If pin GPIO1 is used as output, sets the positive supply (GND_PAD is always used as negative supply). 0 = VANA_1 1 = V5_6
4:3	gpio1_pulls	Boot ROM	R/W	Sets pullup/pulldown to pin GPIO1 (independent of bit <b>gpio1_mode</b> setting). 00 = None 01 = Pulldown 10 = Pullup 11 = N/A
5	gpio1_invert	Boot ROM	R/W	0 = Output signal is not inverted. 1 = Inverts any output signal going to GPIO1. This is useful for the Watchdog output source to make the output active high or low.
7:6	gpio1_out_src	Boot ROM	R/W	Sets the source of pin GPIO1 output. x0 = Bit <b>gpio1</b> (page 47) controlled through the serial interface. 01 = Frequency generator defined by bits <b>gpio_h_time</b> (page 48) and <b>gpio_l_time</b> (page 48). 11 = Interrupt signal (see Interrupt Function on page 49).

Addr: 27		GPIO2 Control Register		
Configures pin GPIO2.				
Bit	Bit Name	Default	Access	Bit Description
1:0	gpio2_mode	Boot ROM	R/W	Sets the direction for pin GPIO2. 00 = Input only. 01 = Output (push and pull). 10 = Output (open drain, only push; only NMOS is active). 11 = Output (open drain, only pull; only PMOS is active).
2	stepdown_fb	Boot ROM	R/W	0 = GPIO2 is used as regulator configurable I/O pin, Step Down DC/DC Converter feedback is at pin VBUCK. 1 = Pin GPIO2 is used as feedback-pin for Step Down DC/DC Converter.
4:3	gpio2_pulls	Boot ROM	R/W	Sets pullup/pulldown to pin GPIO2 (independent of bit <b>gpio2_mode</b> setting). 00 = None                    10 = Pullup 01 = Pulldown              11 = N/A
5	gpio2_invert	Boot ROM	R/W	0 = Output signal is not inverted. 1 = Inverts any output signal going to pin GPIO2. This is useful for the Watchdog output source to make the output active high or low.
7:6	gpio2_out_src	Boot ROM	R/W	Sets the source of pin GPIO2 output. x0 = Bit <b>gpio2</b> (page 47) (controlled through the serial interface). 01 = Frequency generator defined by bits <b>gpio_h_time</b> (page 48) and <b>gpio_l_time</b> (page 48). 11 = Interrupt signal (see Interrupt Function on page 49).

Addr: 28		GPIO3 Control Register		
Configures pin GPIO3.				
Bit	Bit Name	Default	Access	Bit Description
1:0	gpio3_mode	Boot ROM	R/W	Sets the direction for pin GPIO3. 00 = Input only. 01 = Output (push and pull). 10 = Output (open drain, only push; only NMOS is active). 11 = Output (open drain, only pull; only PMOS is active).
3:2	gpio3_voltage	Boot ROM	R/W	If pin GPIO1 is used as output, sets the positive supply (GND_PAD is always used as negative supply). 0 = VANA_1 1 = V5_6
4	gpio3_pulls	Boot ROM	R/W	Sets pullup/pulldown to pin GPIO3 (independent of bit <b>gpio3_mode</b> setting). 00 = None                    10 = Pullup 01 = Pulldown              11 = N/A
5	gpio3_invert	Boot ROM	R/W	0 = Output signal is not inverted. 1 = Inverts any output signal going to pin GPIO3. This is useful for the Watchdog output source to make the output active high or low.
7:6	gpio3_out_src	Boot ROM	R/W	Sets the source of pin GPIO3. x0 = Bit <b>gpio3</b> (page 47) (controlled through the serial interface) 01 = Frequency generator defined by bits <b>gpio_h_time</b> (page 48) and <b>gpio_l_time</b> (page 48). 11 = Interrupt signal (see Interrupt Function on page 49).

Addr: 33		GPIO Signal Register		
Reads the logic signal of the GPIO pins, independently of any other GPIO bit setting.				
Bit	Bit Name	Default	Access	Bit Description
0	gpio1	N/A	R/W	Reads the logic signal from pin GPIO1. If <b>gpio1_out_src</b> (page 46) = 00, this is the output signal at pin GPIO1.
1	gpio2	N/A	R/W	Reads the logic signal from pin GPIO2. If <b>gpio2_out_src</b> (page 46) = 00, this is the output signal at pin GPIO2.
2	gpio3	N/A	R/W	Reads the logic signal from pin GPIO3. If <b>gpio3_out_src</b> (page 47) = 00, this is the output signal at pin GPIO3.
7:3				N/A

### 6.6.2 Programmable Frequency Generator

The Programmable Frequency Generator is controlled by bits **gpio\_h\_time** (page 48) and **gpio\_l\_time** (page 48). It generates a waveform with 0.9 microseconds times **gpio\_h\_time** high-level and 0.9 microseconds times **gpio\_l\_time** low-level. The accuracy of these timings is  $\pm 10\%$ .

The frequency of the Programmable Frequency Generator is:

$$f = 1 / (t_{CLK} * gpio\_h\_time + t_{CLK} * gpio\_l\_time) \quad (EQ 8)$$

where  $t_{CLK} = 1/f_{CLK}$  (page 17) = 1/1.1MHz (typ.) = 0.909 $\mu$ s (typ.)

The purpose of the Programmable Frequency Generator is to have a controlled sweepable frequency or duty cycle source for one of the following:

- General User-Defined Clock
- 8-Bit DAC (output should be filtered by an RC filter)
- (High) Positive and Negative Voltage Generation (see 25V/-20V Voltage Generator on page 48)



### 6.6.3 Programmable Frequency Generator Registers

Addr: 34		GPIO Frequency Control High Time Register		
Configures programmable frequency generator.				
Bit	Bit Name	Default	Access	Bit Description
7:0	gpio_h_time	64 <sub>h</sub>	R/W	Defines the number of system clock cycles (typ. 0.9 $\mu$ s), that the programmable frequency generator at the GPIO output(s) is high. 00 <sub>h</sub> = 0.909 $\mu$ s FF <sub>h</sub> = 232.7 $\mu$ s

Addr: 35		GPIO Frequency Control Low Time Register		
Configures programmable frequency generator.				
Bit	Bit Name	Default	Access	Bit Description
7:0	gpio_l_time	64 <sub>h</sub>	R/W	Defines the number of system clock cycles (typ. 0.9 $\mu$ s), that the programmable frequency generator at the GPIO output(s) is low. 00 <sub>h</sub> = 0.909 $\mu$ s FF <sub>h</sub> = 232.7 $\mu$ s

Addr: 30		Clock Generation Register		
Sets the source for the system clock.				
Bit	Bit Name	Default	Access	Bit Description
0	ext_clk	Boot ROM	R/W	0 = Internal 1.1MHz RC-oscillator. 1 = System clock controlled by pin GPIO1.
7:1				N/A

### 6.6.4 25V/-20V Voltage Generator

Using the Programmable Frequency Generator a voltage generator for +25V or -20V can be built with only 4 external capacitors and 5 external Shottky diodes as shown in the following diagrams.

Figure 23. 25V Positive Voltage Generator Block Diagram

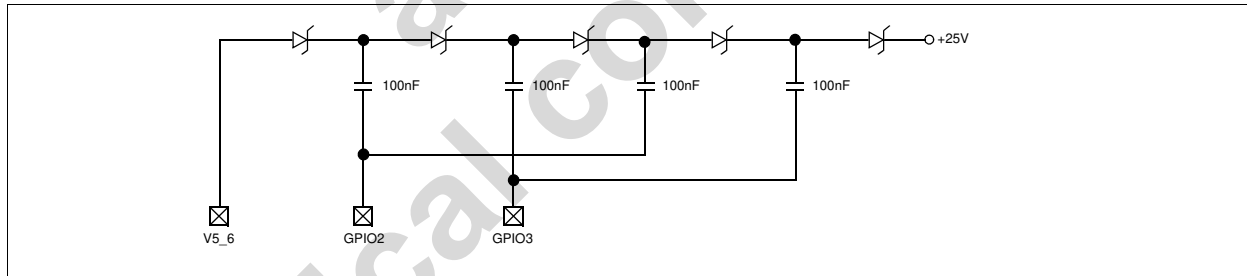
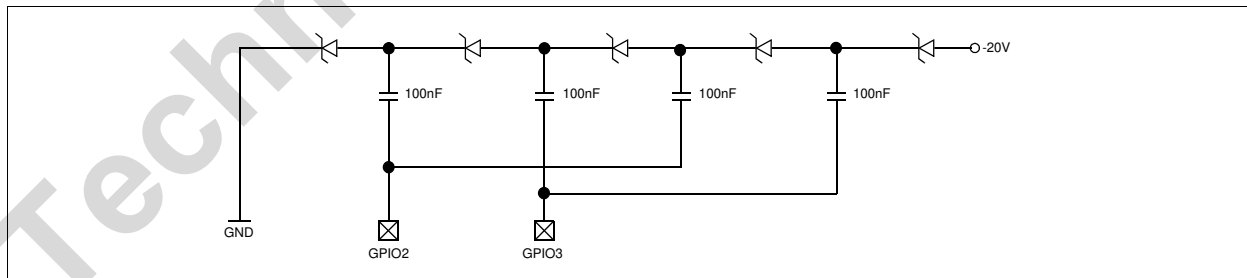

Figure 24. -20V Voltage Generator Block Diagram



**Note:** GPIO2 and GPIO3 must be 180° out of phase, e.g., set bit `gpio2_invert` (page 46) = 1 and bit `gpio3_invert` (page 47) = 0.

### 6.6.5 Interrupt Function

Any of the GPIO pins (GPIO1 - GPIO3) can be configured as interrupt output pins. To enable this function, the corresponding GPIO control bits must be set to 1b. See **gpio1\_out\_src** (page 46), **gpio2\_out\_src** (page 46), or **gpio3\_out\_src** (page 47).

Several signals can be configured as interrupt source using the **Interrupt Enable Register**. A rising edge of an enabled interrupt control signal sets the selected GPIO interrupt output pin = 1.

The **Interrupt Status Register** shows the currently active interrupt signals. Reading this register resets the **Interrupt Status Register** bits and sets the active GPIO pin (GPIO 1 - GPIO3) = 0.

### 6.6.6 Interrupt Registers

Addr: 31		Interrupt Enable Register		
Enables/disables interrupt sources.				
Bit	Bit Name	Default	Access	Bit Description
0	wdog_int_en	Boot ROM	R/W	0 = Disables watchdog alarm as interrupt source signal. 1 = Enables watchdog alarm as interrupt source signal.
1	vchoff_int_en	Boot ROM	R/W	0 = Disables charge termination voltage as interrupt source signal. 1 = Enables charge termination voltage as interrupt source signal.
2	ovtmp_int_en	Boot ROM	R/W	0 = Disables ov_temp_110 (device temperature alert at 110°C). 1 = Enables ov_temp_110 (device temperature alert at 110°C).
3	onkey_int_en	Boot ROM	R/W	0 = Disables pin ON (active high). 1 = Enables pin ON (active high).
4	chdet_int_en	Boot ROM	R/W	0 = Disables charger detection. 1 = Enables charger detection.
5	resume_int_en	Boot ROM	R/W	0 = Disables charger-resume interrupt. 1 = Enables charger-resume interrupt.
6	chgrmv_int_en	Boot ROM	R/W	0 = Disables charger-removed interrupt. 1 = Enables charger-removed interrupt.
7	chgov_int_en	Boot ROM	R/W	0 = Disables charger overvoltage interrupt. 1 = Enables charger overvoltage interrupt.

Addr: 32		Interrupt Status Register		
Displays the status of the interrupt inputs.				
Bit	Bit Name	Default	Access	Bit Description
0	wdog_i	Boot ROM	R/W	0 = Software or hardware watchdog is off or has not rolled over. 1 = Software or hardware watchdog is rollover.
1	vchoff_i	Boot ROM	R/W	0 = Battery voltage is below V <sub>CHOFF</sub> (page 8) threshold. 1 = Battery voltage has reached V <sub>CHOFF</sub> threshold.
2	ovtmp_i	Boot ROM	R/W	0 = Device temperature is below 110°C. 1 = 110°C temperature threshold <b>ov_temp_110</b> (page 59) has been reached.
3	onkey_i	Boot ROM	R/W	0 = ON key has not been pressed. 1 = ON key has been pressed (rising edge).
4	chdet_i	Boot ROM	R/W	Charger detection interrupt, active if <b>chDet</b> (page 19) is falling.
5	resume_i	Boot ROM	R/W	Resume charging interrupt, active if <b>Bat_v</b> (page 21) is falling.
6	chgrmv_i	Boot ROM	R/W	Charger detection interrupt, active if <b>chDet</b> (page 19) is falling.
7	chgov_i	Boot ROM	R/W	Charger over voltage interrupt, active if <b>ChOv</b> (page 21) is rising.

## 6.7 Current Sinks

The AS3604 contains general purpose current sinks intended to control backlights, buzzers, and vibrators. All current sinks have an integrated protection (V<sub>PROTECT</sub>) against overvoltage and can therefore also drive inductive loads. CURR1 is also used as feedback for Step Up DC/DC Converter and in this configuration regulated to 0.8V.

The current sinks can also be used as switches to VSS with configurable impedance as indicated in Table 21.

Table 21. Current Source Characteristics

Symbol	Parameter	Min	Typ	Max	Unit	Notes
ICURRx	curr <sub>x</sub> _current = 01 <sub>h</sub> - FF <sub>h</sub>	0.625		160	mA	curr <sub>x</sub> _sw = 0, resolution = 0.625mA
RPD_SW	curr <sub>x</sub> _current = 01 <sub>h</sub> - FF <sub>h</sub>	0.3		77	Ω	curr <sub>x</sub> _sw = 1, 00 <sub>h</sub> = open, resolution = 0.3Ω
V <sub>PROTECT</sub>	Maximum voltage at pin CURRx to protect driver transistor			V <sub>BAT</sub> + 2.0V	V	I <sub>SINK</sub> ≥ 20mA (1)

**Note:** If a voltage higher than V<sub>PROTECT</sub> is applied to pins CURR1 - CURR4, a current of more than 20mA will flow into the AS3604. This protects the device from voltage rises caused by inductive loads.

### 6.7.1 Current Sink Registers

The current sinks are controlled by the registers listed in Table 22.

Table 22. Current Sink Register Summary

Name	Addr	B7	B6	B5	B4	B3	B2	B1	B0	Page
CURR1 Value Register	36	curr1_current								50
CURR2 Value Register	37	curr2_current								50
CURR3 Value Register	38	curr3_current								51
CURR4 Value Register	39	curr4_current								51
CURR Control Register	40	curr4_ctrl	curr3_ctrl		curr2_ctrl		curr1_ctrl			51
CURR Mode Register	41	N/A		curr4_sw		curr3_sw	curr2_sw	curr1_sw		51
CURR GPIO Map Register	42	curr4_gpio		curr3_gpio		curr2_gpio		curr1_gpio		52

Addr: 36		CURR1 Value Register				
		Sets the current / resistance of current source CURR1.				
Bit	Bit Name	Default	Access	Bit Description		
7:0	curr1_current	00 <sub>h</sub>	R/W	00 <sub>h</sub> 01 <sub>h</sub> ... FF <sub>h</sub>	curr1_sw (page 51) = 0 Power Down 0.625mA ... 160mA	curr1_sw = 1 Open 77Ω ... 0.3Ω

Addr: 37		CURR2 Value Register				
		Sets the current / resistance of current source CURR2.				
Bit	Bit Name	Default	Access	Bit Description		
7:0	curr2_current	00 <sub>h</sub>	R/W	00 <sub>h</sub> 01 <sub>h</sub> ... FF <sub>h</sub>	curr2_sw (page 51) = 0 Power Down 0.625mA ... 160mA	curr2_sw = 1 Open 77Ω ... 0.3Ω

Addr: 38		CURR3 Value Register				
Sets the current / resistance of current source CURR3.						
Bit	Bit Name	Default	Access	Bit Description		
7:0	curr3_current	00h	R/W	00h 01h ... FFh	curr3_sw (page 51) = 0 Power Down 0.625mA ... 160mA	curr3_sw = 1 Open 77Ω ... 0.3Ω

Addr: 39		CURR4 Value Register				
Sets the current / resistance of current source CURR4.						
Bit	Bit Name	Default	Access	Bit Description		
7:0	curr4_current	00h	R/W	00h 01h ... FFh	curr4_sw (page 51) = 0 Power Down 0.625mA ... 160mA	curr4_sw = 1 Open 77Ω ... 0.3Ω

Addr: 40		CURR Control Register				
Selects software/ hardware control of current sources.						
Bit	Bit Name	Default	Access	Bit Description		
1:0	curr1_ctrl	00b	R/W	00 = Pin CURR2 is turned off. 01 = Pin CURR2 is active. 1x = GPIO control; pin is active when curr1_gpio (page 52) = 1.		
3:2	curr2_ctrl	00b	R/W	00 = Pin CURR2 is turned off. 01 = Pin CURR2 is active. 1x = GPIO control; pin is active when curr2_gpio (page 52) = 1.		
5:4	curr3_ctrl	00b	R/W	00 = Pin CURR4 is turned off. 01 = Pin CURR4 is active. 1x = GPIO control; pin is active when curr3_gpio (page 52) = 1.		
7:6	curr4_ctrl	00b	R/W	00 = Pin CURR4 is turned off. 01 = Pin CURR4 is active. 1x = GPIO control; pin is active when curr4_gpio (page 52) = 1.		

Addr: 41		CURR Mode Register				
Selects operation mode for current sources.						
Bit	Bit Name	Default	Access	Bit Description		
0	curr1_sw		R/W	0 = Pin CURR1 is operating as current sink. 1 = Pin CURR1 is operating as resistive load current. Resistance is defined by bits curr1_current (page 50).		
1	curr2_sw		R/W	0 = Pin CURR2 is operating as current sink. 1 = Pin CURR2 is operating as resistive load current. Resistance is defined by bits curr2_current (page 50).		
2	curr3_sw		R/W	0 = Pin CURR3 is operating as current sink. 1 = Pin CURR3 is operating as resistive load current. Resistance is defined by bits curr3_current (page 51).		
3	curr4_sw		R/W	0 = Pin CURR4 is operating as current sink. 1 = Pin CURR4 is operating as resistive load. Resistance is defined by bits curr4_current (page 51).		
7:4				N/A		

Addr: 42		CURR GPIO Map Register		
Selects GPIO pin to control current sources.				
Bit	Bit Name	Default	Access	Bit Description
1:0	curr1_gpio	Boot ROM	R/W	If bits <b>curr1_ctrl</b> (page 51) = 1x, the following pin is assigned for turning the CURR1 pin on and off. 00 = GPIO1 01 = GPIO2 10 = GPIO3
3:2	curr2_gpio	Boot ROM	R/W	If bits <b>curr2_ctrl</b> (page 51) = 1x, the following pin is assigned for turning the CURR2 pin on and off. 00 = GPIO1 01 = GPIO2 10 = GPIO3
5:4	curr3_gpio	Boot ROM	R/W	If bits <b>curr3_ctrl</b> (page 51) = 1x, the following pin is assigned for turning the CURR3 pin on and off. 00 = GPIO1 01 = GPIO2 10 = GPIO3
7:6	curr4_gpio	Boot ROM	R/W	If bits <b>curr4_ctrl</b> (page 51) = 1x, the following pin is assigned for turning the CURR4 pin on and off. 00 = GPIO1 01 = GPIO2 10 = GPIO3

## 6.8 Audio Amplifier

The integrated Audio Amplifier provides real CD-quality audio and can be used as a headphone amplifier for portable devices. It is designed to meet the operational and power requirements of portable devices by delivering:

- 1WRMS continuous power into 8Ω differential at 5V supply
- 2 x 50mWRMS into 32Ω single-ended at 5V supply

The Audio Amplifier provides the following operational features:

- Total harmonic distortion is less than 0.1% at 1kHz and the quiescent current does not exceed 8mA.
- Power supply rejection is always better than 50dB and allows direct connection to noisy batteries, e.g. in TDMA systems.
- The internal programmable gain can be used for volume and balance control.
- Only a few external components are required for AC-coupling and reference bypass.
- An internal smooth-rampup circuit ensures pop- and click-less startup without expensive and bulky external relays.
- Device stability even with high capacitive loads of 1nF and does not require external snubber networks.
- Inputs are high-impedance in power-down.

Figure 25. Audio Amplifier Block Diagram – Stereo Mode

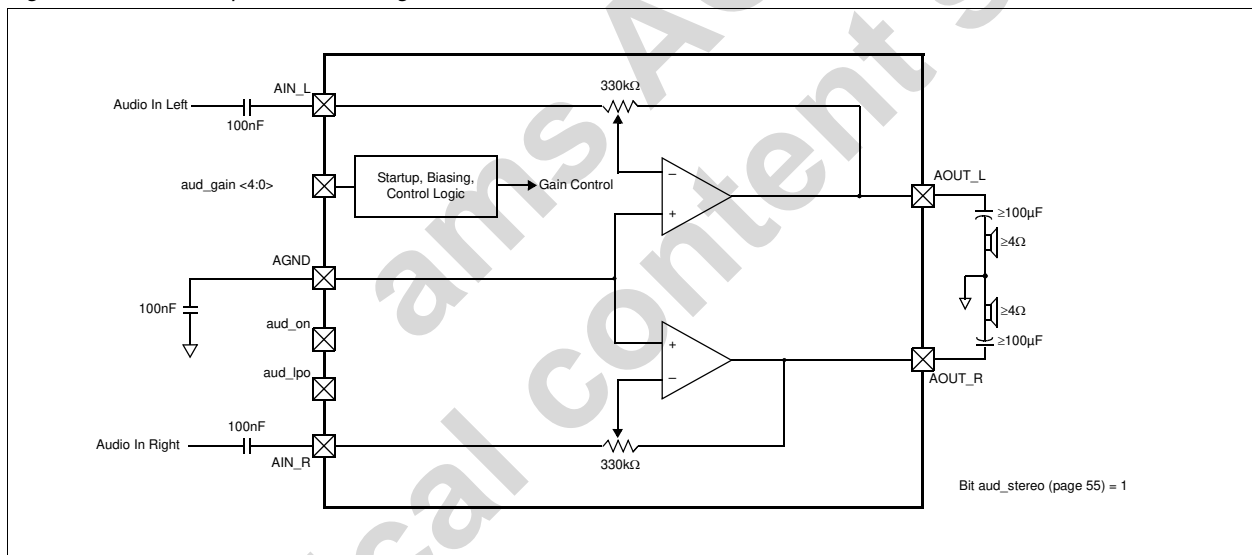

**Note:** The value of the audio output decoupling capacitors depends on the speaker impedance and the desired minimum output frequency:

$$C = 1/(2\pi P f R) \quad (EQ 9)$$

**Where:**

f = minimum output cutoff frequency, -3dB point.

R = speaker impedance in Ω.

C = decoupling capacitance in F.

Figure 26. Audio Amplifier Block Diagram – Differential Mode

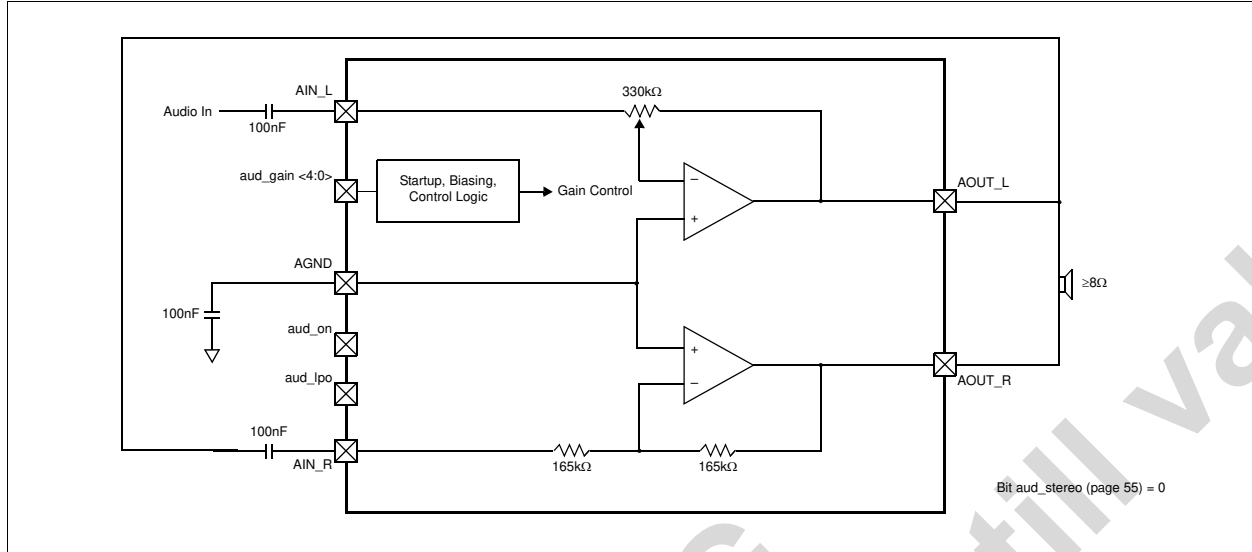

Table 23. Audio Amplifier Characteristics

Symbol	Parameter	Min	Typ	Max	Unit	Notes
V <sub>DDH</sub>	Supply Voltage Range (VBAT_3)	3		5.5	V	
PSRR	Power Supply Rejection Ratio, Differential		70		dB	f = 1kHz
			50			f = 20kHz
PSRR	Power Supply Rejection Ratio, Single-Ended		50		dB	f = 1kHz
			40			f = 20kHz
I <sub>OFF</sub>	Shut Down Current			100	nA	
I <sub>VDDH</sub>	Supply Current (Differential Mode)			9	mA	aud_lpo (page 55) = 0 and aud_ib_red (page 55) = 00
				4		aud_lpo = 1 and aud_ib_red = 00
				2.7		aud_lpo = 1 and aud_ib_red = 11
I <sub>VDDH</sub>	Supply Current (Stereo Mode)			8	mA	aud_lpo = 0 and aud_ib_red = 00
				3		aud_lpo = 1 and aud_ib_red = 00
				1.7		aud_lpo = 1 and aud_ib_red = 11
R <sub>LOAD</sub>	Output Load	8			Ω	Differential mode
		4				Stereo mode
THD+N	Total Harmonic Distortion			0.1	%	P <sub>OUT</sub> = 1W, R <sub>LOAD</sub> = 8Ω, f = 1kHz Differential
				0.5		P <sub>OUT</sub> = 1W, R <sub>LOAD</sub> = 8Ω, f = 20kHz Differential
				0.05		P <sub>OUT</sub> = 50mW, R <sub>LOAD</sub> = 32Ω, f = 1kHz Single-Ended
				0.2		P <sub>OUT</sub> = 50mW, R <sub>LOAD</sub> = 32Ω, f = 20kHz Single-Ended
SNR	Signal to Noise Ratio	84	91		dB	VBAT=3.7V, not tested, guaranteed per design
A <sub>0</sub>	Gain	-22	0	20	dB	Programmable gain: A <sub>OUT</sub> /A <sub>IN</sub>
ΔA <sub>x</sub>	Programmable Gain Step-Size		3		dB	
I <sub>OV_ON</sub>	Overcurrent On_limit	591	650	744	mA	Current rising into PMOS driver; when aud_lpo = 0 and aud_ib_red = 00, and aud_overcur = 1 .

Table 23. Audio Amplifier Characteristics (Continued)

Symbol	Parameter	Min	Typ	Max	Unit	Notes
lov_off	Overcurrent Off_limit	397	550	650	mA	Current decreasing in PMOS driver; when <b>aud_lpo</b> = 0 and <b>aud_ib_red</b> = 00, and <b>aud_overcur</b> (page 55) is cleared.
lov_hyst	Overcurrent Hysteresis		100		mA	

### 6.8.1 Audio Amplifier Registers

Addr: 43		Audio Control Register		
Configures the Audio Amplifier.				
Bit	Bit Name	Default	Access	Bit Description
0	aud_on	0	R/W	Activates the Audio Amplifier. 0 = Audio amplifier off; inputs AIN_L and AIN_R are high-impedance. 1 = Audio amplifier on.
1	aud_lpo	0	R/W	Select Low-Power Operation; reduced output power. 0 = Use for speakers < 32Ω (nominal impedance) in stereo mode; < 64Ω differential. 1 = Use for speakers ≥ 32Ω (nominal impedance) in stereo mode; ≥ 64Ω differential.
3:2	aud_ib_red	00b	R/W	Reduced bias current into Audio Amplifier circuit. 00 = Use for speakers < 8Ω (nominal impedance) in stereo mode; < 16Ω differential. 01 = N/A 10 = N/A 11 = Use for speakers ≥ 8Ω (nominal impedance) in stereo mode; ≥ 16Ω differential.
7:4	aud_gain	0000b	R/W	Audio Amplifier gain adjust. 0000 = Output off      1000 = 0dB 0001 = -22dB          1001 = +2dB 0010 = -19dB          1010 = +5dB 0011 = -16dB          1011 = +8dB 0100 = -13dB          1100 = +11dB 0101 = -10dB          1101 = +14dB 0110 = -7dB            1110 = +17dB 0111 = -4dB            1111 = +20dB

Addr: 65		Audio Control 2 Register		
Configures the Audio Amplifier.				
Bit	Bit Name	Default	Access	Bit Description
0	aud_stereo	1	R/W	Selects audio mode. 0 = Differential mono mode (connect pin AIN_R to pin AOUT_L) 1 = Stereo mode.
1	aud_overcur	00	R	0 = Normal operation; audio output current below limit of <b>IOV_ON</b> (page 54). 1 = Audio output current exceeds limit ( <b>IOV_ON</b> ).
3:2	aud_pulldwn	00b	R/W	Audio amplifier output pulldown control; active if <b>aud_on</b> (page 55)=0. 00 = 30μA 01 = 0.6mA 10 = 1.2mA 11 = 2.5mA
7:4				N/A



## 7 System Supervisory Functions

### 7.1 Reset

RESET is an active low bi-directional pin; an external pullup to LDO VANA\_1 has to be added (see Digital Input/Output DC/AC Characteristics on page 64). During each reset cycle the following states are controlled by the AS3604:

- Pin RESET is Forced to GND
- Programmable Power-off Function
- Programmable Power-on Sequence and Regulator Voltages
- Programmable Reset Timer
- All Register bits Set to Default Values after Power-On (except the **Audio Control 2 Register (page 55)**, the **Interrupt Status Register (page 49)**, and the **Boot Sequence Detection Register (page 63)**).

**Note:** Programming is controlled by the internal mask-ROM and the external resistor RPROGRAM. The first address of each ROM-bank defines which of the regulators are turned off during reset.

#### 7.1.1 Reset Conditions

Reset can be activated from 7 different sources:

- Power On (Battery or Charger Insertion)
- Low Battery
- Power Off Mode
- Software Forced Reset
- Externally Triggered through the RESET Pin
- Overtemperature
- Watchdog
- Momentary Power Loss Detection

##### *Power On (Battery or Charger Insertion)*

There are two types of voltage dependent resets:

- VPOR – Monitors the voltage on pin V2\_5. LDO V2\_5 uses the voltage VCHARGER or VBAT as its source.
- VRESET – Monitors the voltage on VBAT pins. Pin RESET is only released if  $V_{2\_5} > VPOR$  and  $VBAT > VRESETRISE$ .

##### *Low Battery*

A reset is automatically generated if VBAT drops below VRESETFALLING for a minimum period (VRESETMASK).

Table 24. Reset Levels

Symbol	Parameter	Min	Typ	Max	Unit	Notes
VPOR	Overall power on reset	1.5	2.0	2.3	V	Monitor voltage on pin V2_5; power on reset for all internal functions. <b>Note:</b> Pin RESET stays low until $V_{2\_5} > VPOR$
VRESETRISE	Reset level for VBAT rising		3.1		V	Monitor voltage on pin VBAT; rising level.
VRESETFALLING	Reset level for VBAT falling <sup>1</sup>		2.8		V	Monitor voltage on pin VBAT; falling level.
VRESETMASK	Mask time for VRESETFALLING		40		µs	Duration for $VBAT < VRESETFALLING$ until a reset cycle is started. <sup>2</sup>
TPOWERLOSS	Interval for recovery of power loss on VBAT	100	250	500	ms	If the duration of a power loss on VBAT is below this duration, the system will restart

1. VRESETFALLING is only accepted if the reset condition is longer than VRESETMASK. This guard time is used to avoid a complete reset of the system in case of short drops of VBAT.
2. VRESET signal is debounced with the specified mask time for rising- and falling-slope of VBAT. The default time is 40µs and it can be programmed from 0µs to 200µs with the register reset-mask timer.

##### *Momentary Power Loss Detection*

If the battery voltage (VBAT) drops below VRESETFALLING and rises above VRESETRISE within TPOWERLOSS, the AS3604 automatically restarts and sets bit **tmp\_pwr\_loss (page 57)** to 1. This can be used to detect short VBAT interruptions, e.g., due to a dropped mobile phone call.

### Power Off

Setting bit **power\_off** (page 57) = 1 puts the AS3604 into ultra low-power mode. To start a complete reset cycle, the AS3604 waits until the external pin ON is pulled high, the Battery Charger is inserted, or level VPOR is reached. Bit **power\_off** is automatically cleared by this reset cycle. During power off state, all circuits are turned off except LDO V2\_5, thus the current consumption of the AS3604 is reduced to less than 10µA. The digital part is supplied by LDO V2\_5, all other circuits are turned off in this mode, including internal references and oscillator.

**Note:** All registers except the **Reset Control Register** (page 57) are set to their default value after power-on.

### Software Forced Reset

Setting bit **force\_reset** (page 57) = 1 immediately initiates a reset cycle, and is automatically cleared during a reset.

### External Triggered Reset

If the pin RESET is pulled from high to low by an external source (microprocessor or button) a reset cycle is initiated.

### Overtemperature Reset

The reset cycle can be started by overtemperature conditions (page 59).

### Watchdog Reset

If the Watchdog is armed (bit **wtdg\_on** (page 60) = 1 and bit **wtdg\_res\_on** (page 60) = 1) and the timer expires, a reset is initiated. Refer to page 60 for information about the Watchdog block.

## 7.1.2 Reset Registers

Addr: 58		Reset Control Register		
Controls reset and power off.				
Bit	Bit Name	Default	Access	Bit Description
0	force_reset	0b	R/W	0 = Normal operation. 1 = Initiates a complete reset cycle.
1	power_off	0b	R/W	0 = Normal operation. 1 = Initiates power-off mode where all LDOs are turned off except LDO V2_5. The AS3604 waits for a rising edge on pin ON or until the battery charger is detected.
2	on_input	N/A	R	Static indication of ON input pin. 0 = ON input pin is low. 1 = ON input pin is high (external ON key depressed).
5:3	reset_reason	N/A	R	Indicates to the software the reason for the most recent reset. 000 = VPOR (page 56) was reached (initial battery or charger insertion). 001 = VRESETFALLING (page 56) was reached (VBAT < 2.75V). 010 = Software forced by bit <b>force_reset</b> . 011 = Software forced by bit <b>power_off</b> and ON was pulled high. 100 = Software forced by bit <b>power_off</b> and a Battery Charger detected. 101 = Externally triggered through pin RESET. 110 = Reset caused by overtemperature T140. 111 = Reset caused by Watchdog.
6	tmp_pwr_loss	0b	R	0 = Normal startup. 1 = A momentary power loss condition was detected.
7				N/A
Addr: 19		Reset Timer Register		
Sets the RESET timer value.				
Bit	Bit Name	Default	Access	Bit Description
2:0	res_timer	Boot ROM	R/W	Set RESTIME 000 RESTIME = 10ms      100 RESTIME = 50ms 001 RESTIME = 20ms      101 RESTIME = 60ms 010 RESTIME = 30ms      110 RESTIME = 70ms 011 RESTIME = 40ms      111 RESTIME = 80ms
5:3	reset_mask_timer	11b	R/W	Set MASKTIME 000 = MASKTIME = 0µs      100 MASKTIME = 80µs 001 MASKTIME = 5µs      101 MASKTIME = 120µs 010 MASKTIME = 10µs      110 MASKTIME = 160µs 011 MASKTIME = 40µs      111 MASKTIME = 200µs
7:5				N/A

### 7.1.3 Reset Cycle

During a reset cycle, pin RESET is forced low for at least the time specified by bits **res\_timer** (page 57) and then all register bits are set to their default values except bit **ov\_temp\_140** (page 59) and the **Boot Sequence Detection Register** (page 63).

During the reset time, a normal startup is initiated (refer to Startup on page 58) and the reset is active until the reset timer (set by bits **res\_timer**) expires. The voltage on pin RESET is then pulled high by the external resistor and the whole system is leaving the reset state.

### 7.1.4 res\_con: Reset Control

Reset is internally generated from a power on detection circuit (page 56) and provided to the internal logic as well as externally through the open-drain pin RESET. This pin can also be forced externally by pulling it low. Additionally Reset can be forced by software by setting bit **force\_reset** (page 57) = 1.

## 7.2 Startup

### 7.2.1 Normal Startup

During a normal reset cycle (page 56), after  $V_{2.5}$  is above  $V_{POR}$  and  $V_{BAT}$  is above  $V_{RESETRISE}$ , a normal startup is initiated as follows:

1. The external capacitor on pin CREF is charged to 1.8V.
2. A 3-bit A/D conversion of resistor RPROGRAM value is performed, selecting 1 of 8 boot configurations – see bit **rom\_adr** (page 63).
3. The DC/DC converters and LDOs are sequentially powered up according to the selected Boot ROM configuration (address  $01_h - 31_h$  – see Table 35 on page 68).
4. Depending on the Boot ROM setting (address 0 Bit 7, Auto-Shutdown):
  - a. The AS3604 enters shutdown mode if no momentary power loss is detected (only valid through initial startup, not during a reset cycle).
  - or-
  - b. The Reset-Timer is set by the Boot ROM and the reset is released when the Reset-Timer expires (pin RESET is pulled high).

### 7.2.2 Programmable Startup Sequences

For more details on the available power-on sequences stored in the Boot-ROM, please refer to document AS3604\_BootSeq.PDF, available from *austriamicrosystems*, AG upon request.

### 7.2.3 Startup from Battery Charger

If the voltage on pin VCHARGER is within  $V_{STARTCHARGER}$ , the Battery Charger is started in all cases, even with  $V_{BAT} = 0V$ . This allows the battery to be charged (even from deep discharge) and a normal startup to proceed.

Table 25. Battery Charger Startup Conditions

Symbol	Parameter	Min	Typ	Max	Unit	Notes
VSTARTCHARGER	Voltage on pin VCHARGER for the AS3604 to start	4.35	5.0	15	V	On pin VCHARGER.

## 7.3 Protection Functions

The Step Up DC/DC Converter, the Step Down DC/DC Converter, and all LDOs have integrated overcurrent protection. Overtemperature protection of the AS3604 is also built-in and can be activated with the serial interface bit **temp\_pmc\_on** (page 59).

The AS3604 has two temperature indicators:

- **ov\_temp\_110** (page 59) – Automatically reset if the overtemperature condition is removed.
- **ov\_temp\_140** (page 59) – Must be reset via the serial interface with bit **rst\_ov\_temp\_140** (page 59). If **ov\_temp\_140** is set, an automatic reset of the complete AS3604 is initiated. Bit **ov\_temp\_140** is not cleared by this reset cycle to indicate the reason for this (unexpected) shutdown. It must be cleared intentionally by bit **rst\_ov\_temp\_140**. The cause of this reset is stored in the **Reset Control Register** (page 57). This allows a detection of the reset cause, after the device has restarted.

### 7.3.1 TMP\_SV: Temperature Supervision

The AS3604 includes an integrated temperature sensor, implemented to provide overtemperature protection of the device. It generates flags linked to the two temperature thresholds:

- **T110** – 110° threshold. Sets **ov\_temp\_110** (page 59), signalling the 110° overtemperature condition. Thus software can react and shut down power-consuming functions in order to decrease the device's temperature.
- **T140** – 140° threshold. Reaching this temperature level generates a Reset, when **temp\_pmc\_on** (page 59) is enabled. This sets all regulators into power-down mode and stops battery charging.

### 7.3.2 Overtemperature Detection

Table 26. Overtemperature Detection Parameters

Symbol	Parameter	Min	Typ	Max	Unit
T110	ov_temp_110 Rising Threshold	95	110	125	°C
		203	230	257	°F
T140	ov_temp_140 Rising Threshold	125	140	155	°C
		257	284	311	°F
Thyst	ov_temp_110 and ov_temp_140 Hysteresis		5		°C

### 7.3.3 Overtemperature Detection Register

Addr: 59		Overtemperature Control Register			
		Device temperature supervision.			
Bit	Bit Name	Default	Access	Bit Description	
0	temp_pmc_on	0	R/W	Activates/deactivates temperature supervision. Default: Off - all other bits are only valid if set to 1. 0 = Temperature supervision is disabled. No reset will be generated when the device temperature exceeds 140°C. 1 = Temperature supervision is enabled.	
1	ov_temp_110	N/A	R	1 = Warning flag indicating that the device temperature has exceeded 110°C.	
2	ov_temp_140	N/A	R	1 = Indicates that the device overtemperature has exceeded 140°C. This bit is not cleared by the automatic reset caused by this flag. It must be cleared using bit <b>rst_ov_temp_140</b> .	
3	rst_ov_temp_140	0	W	Used to clear bit <b>ov_temp_140</b> ; first set this bit = 1 and then set it =0.	
5:4	temp_test	00	R/W	Only used for production; must always be set to 00.	
6	tco_110_a	N/A	R	Only used for production – direct output of T110 comparator.	
7	tco_140_a	N/A	R	Only used for production – direct output of T140 comparator.	

## 7.4 Watchdog Block

The AS3604 includes a Watchdog block to detect a deadlock of the connected controller.

If the Watchdog block is active (**wtdg\_on** (page 60) = 1), it must get a continuous trigger signal within a programmable timer window. If there is no signal for a certain time period from a defined GPIO pin or bit **wtdg\_sw\_sig** (page 61), the Watchdog block starts either a complete reset – bit **wtdg\_res\_on** (page 60) must be set to 1 – or sets interrupt flag **wdog\_i** (page 49).

The Watchdog timer window is defined by bits:

- **wtdg\_min\_timer** (page 61)
- **wtdg\_max\_timer** (page 61)

The trigger signal can be configured using bits:

- **wtdg\_trigger** (page 60)
- **wtdg\_sw\_sig** (page 61) – Watchdog is reset by software
- **wtdg\_gpio\_input** (page 60) – Watchdog is reset by hardware (GPIO)

Any of the general purpose input/outputs can be configured as inputs using bit **wtdg\_gpio\_input** (page 60), and outputs using bits **gpio1\_out\_src** (page 46), **gpio2\_out\_src** (page 46), or **gpio3\_out\_src** (page 47) = 11, for the Watchdog. While the GPIO input must be continuously re-triggered in order to avoid a Watchdog interrupt, the GPIO output will generate an interrupt when the Watchdog runs over – **wdog\_int\_en** (page 49).

### 7.4.1 Watchdog Registers

The Watchdog is controlled by the registers listed in Table 27.

Table 27. Low Dropout Regulators Register Summary

Name	Addr	B7	B6	B5	B4	B3	B2	B1	B0	Page
Watchdog Control Register	46		N/A		wtdg_trigger	wtdg_gpio_input		wtdg_res_on	wtdg_on	60
Watchdog_min Timer Register	47				wtdg_min_timer					61
Watchdog_max Timer Register	48				wtdg_max_timer					61
Watchdog Software Signal Register	49				N/A				wtdg_sw_sig	61

Addr: 46		Watchdog Control Register			
		Controls the Watchdog block.			
Bit	Bit Name	Default	Access	Bit Description	
0	wtdg_on	0	R/W	0 = Disables the Watchdog block. 1 = Enables the Watchdog block.	
1	wtdg_res_on	1	R/W	If the Watchdog expires and this bit = 1, a reset cycle will be started. Refer to page 56 for information about reset cycles. 0 = A watchdog overflow does not generate a reset. 1 = A watchdog overflow generates a reset.	
3:2	wtdg_gpio_input	00	R/W	Specifies the input pin of the Watchdog if bit <b>wtdg_trigger</b> = 1. 00 = GPIO1 01 = GPIO2 10 = GPIO3 11 = Do not use this setting.	
4	wtdg_trigger	0	R/W	Select type of trigger (software or hardware). 0 = Use bit <b>wtdg_sw_sig</b> (page 61) as trigger signal for the Watchdog. 1 = Use the pin defined by bit <b>wtdg_gpio_input</b> as trigger signal for the Watchdog.	
7:5				N/A	

Addr: 47		Watchdog_min Timer Register		
Sets the minimum Watchdog trigger time.				
Bit	Bit Name	Default	Access	Bit Description
7:0	wtdg_min_timer	00 <sub>h</sub>	R/W	00 <sub>h</sub> = 0s 01 <sub>h</sub> = 7.5ms ... FF <sub>h</sub> = 1.9s.

Addr: 48		Watchdog_max Timer Register		
Sets the maximum Watchdog trigger time.				
Bit	Bit Name	Default	Access	Bit Description
7:0	wtdg_max_timer	FF <sub>h</sub>	R/W	01 <sub>h</sub> = 7.5ms ... FF <sub>h</sub> = 1.9s. <b>Caution:</b> Do not set these bits = 00 <sub>h</sub> .

Addr: 49		Watchdog Software Signal Register		
Resets the Watchdog block by software.				
Bit	Bit Name	Default	Access	Bit Description
0	wtdg_sw_sig	0	R/W	Trigger input by the serial interface if <b>wtdg_trigger</b> (page 60) = 0. 0 = Force watchdog trigger = low (see Figure 27). 1 = Force watchdog trigger = high (see Figure 27).
7:1				N/A

Figure 27. Watchdog Timing Diagram

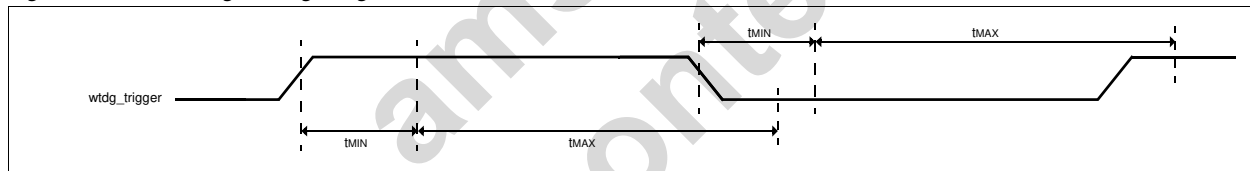

## 7.5 Internal Reference Circuits

The internal reference circuits (V, I, fCLK) require the external components listed in Table 28.

Table 28. Reference External Components

Symbol	Parameter	Min	Typ	Max	Unit	Notes
CEXT	External filter capacitor	-20%	100	+20%	nF	Ceramic low-ESR capacitor between pins CREF and VSS
REXT	External resistor	-1%	220	+1%	kΩ	Between pins RBIAS and VSS

Table 29. References Characteristics

Symbol	Parameter	Min	Typ	Max	Unit	Notes
VCEXT	Reference voltage	-1%	1.8	+1%	V	Low noise trimmed voltage reference - connected to pin CREF; do not load.
fCLK	Internal reference clock	1.0	1.1	1.2	MHz	Trimmed clock reference

To reduce the current consumption of the AS3604, internal references circuit scan be set into a special low-power mode with bit **low\_power\_on** (page 62).

## 7.5.1 Internal Reference Registers

Addr: 45		References Control Register		
Configures low-power mode.				
Bit	Bit Name	Default	Access	Bit Description
0	low_power_on	0	R/W	0 = Standard mode or controlled by GPIO, if <b>low_power_gpio_on</b> = 1. 1 = Low-power mode; all parameters except noise (see LDO parameters, section 6.3) are still valid.
1	low_power_gpio_on	0	R/W	If set and <b>low_power_on</b> = 0 then the low-power mode is controlled by a GPIO pin. 0 = Low-power mode disabled for GPIO control. 1 = Low-power mode is activated by GPIO pin ( <b>low_power_gpio</b> ). <b>low_power_on</b> must be enabled.
3:2	low_power_gpio	00	R/W	Specifies the pin to be used as GPIO control. 00 = GPIO1 01 = GPIO2 10 = GPIO3 11 = GPIO3
4	low_power_gpio_pol	0	R/W	0 = Low-power mode is activated. If the selected GPIO input, bit <b>low_power_gpio</b> = 1. 1 = Low-power mode is activated. If the selected GPIO input, bit <b>low_power_gpio</b> = 0.
7:5				N/A



## 7.6 Low Power Mode

Bit **low\_power\_on** (page 62) controls low-power mode. In low-power mode the integrated voltage reference and the temperature supervision comparators operate in pulsed mode. This reduces the quiescent current of the AS3604 by 45µA (typical). Because of the pulsed function, the LDO output noise parameters do not meet the specification in low-power mode but the full functionality is still available.

**Note:** Low-power mode can be activated by hardware using one of the GPIO pins, or by software by setting bit **low\_power\_on** (page 62) = 1.

## 7.7 Boot Sequence Detection

The AS3604 startup and reset sequences are highly configurable. The configuration of these sequences is defined by the ratio of the external bias resistors RBIAS and RPROGRAM.

At the beginning of each reset cycle a 3-bit A/D conversion is performed. The result of this conversion is used to select 1 of 8 possible address-ranges of an internal mask-programmable ROM. The information stored in this ROM defines the following parameters:

- The voltage regulators will be turned off at the beginning of the reset cycle.
- The power-on sequence and voltage levels of up to 7 LDOs and the Step-Down DCDC-converter.
- The duration of the reset cycle (4 possible timer values).

For the specified value of  $R_{EXT} = 220k\Omega$ , values of RPROGRAM listed in Table 30 select the 8 possible address ranges.

Table 30. RPROGRAM Values

Selected Bank	RPROGRAM (Ideal)	Closest E24 Resistor Value (tol. = ± 5%)
Bank 0	Open	Open
Bank 1	320kΩ	330kΩ
Bank 2	160kΩ	160kΩ
Bank 3	80kΩ	82kΩ
Bank 4	40kΩ	39kΩ
Bank 5	20kΩ	20kΩ
Bank 6	10kΩ	10kΩ
Bank 7	5kΩ	5.1kΩ

### 7.7.1 ON Detection Register

Addr: 60		Boot Sequence Detection Register		
Displays the detected Boot ROM sequence.				
Bit	Bit Name	Default	Access	Bit Description
2:0	rom_adr	000b	R	Selected boot ROM bank (as set by RPROGRAM). Registers 01 through 31 (see Table 35 on page 68) are configured according to the selected bank.
3	rom_valid	0	R	0 = Not ready. 1 = Boot ROM bank ( <b>rom_adr</b> ) is valid.
7:4				N/A



## 7.8 Serial Interface

The AS3604 provides for the automatic selection of serial interface modes SPI and I<sup>2</sup>C. In I<sup>2</sup>C mode two of four signals can be defined to support this mode switching.

### 7.8.1 Digital Input/Output DC/AC Characteristics

The output voltage LDO VANA\_1 is used as supply voltage of the pins.

Bit `Ido_ana1_on` (page 37) should never be set to 0, as register access over the serial interface is not possible in this case. It is only set to 0 automatically:

- In power-off state (where it is set to 0 automatically)
- During the startup sequence (Boot ROM Addresses 9:13)
- At reset-state (Boot ROM Address 0)

Table 31. DC Characteristics Input Pin SCLK/SDI

Parameter	Symbol	Min	Max	Unit	Notes
High-Level Input Voltage	V <sub>IH</sub>	0.7 x VANA_1		V	
Low-Level Input Voltage	V <sub>IL</sub>		0.3 x VANA_1	V	
Hysteresis	V <sub>HYS</sub>	0.2 x VANA_1		V	
Input Leakage Current	I <sub>LEAK</sub>	-5	5	μA	to VANA_1 and GND_PAD

Table 32. DC Characteristics Input/Output Pin SCSB/SDO

Parameter	Symbol	Min	Max	Unit	Notes
High-Level Input Voltage	V <sub>IH</sub>	0.7 x VANA_1		V	
Low-Level Input Voltage	V <sub>IL</sub>		0.3 x VANA_1	V	
Hysteresis	V <sub>HYS</sub>	0.2 x VANA_1		V	
Input Leakage Current	I <sub>LEAK</sub>	-5	5	μA	to VANA_1 and GND_PAD
High-Level Output Voltage	V <sub>OH</sub>	0.8 x VANA_1		V	at -2.0mA
Low-Level Output Voltage	V <sub>OL</sub>		0.2 x VANA_1	V	at 2.0mA
Capacitive Load	C <sub>LOAD</sub>		50	pF	

Table 33. DC Characteristics Input/Output Open Drain Pin RESET

Parameter	Symbol	Min	Max	Unit	Notes
High-Level Input Voltage	V <sub>IH</sub>	0.7 x VANA_1		V	
Low-Level Input Voltage	V <sub>IL</sub>		0.3 x VANA_1	V	
Hysteresis	V <sub>HYS</sub>	0.2 x VANA_1		V	
Input Leakage Current	I <sub>LEAK</sub>	-5	5	μA	to VANA_1 and GND_PAD
Low-Level Output Voltage	V <sub>OL</sub>		0.2 x VANA_1	V	at 2mA
Capacitive Load	C <sub>LOAD</sub>		50	pF	
External Pullup Resistor	RPULLUP		100k	Ω	Connect to VANA_1

### 7.8.2 SPI Compatible Serial Interface

Figure 28. SPI Waveform

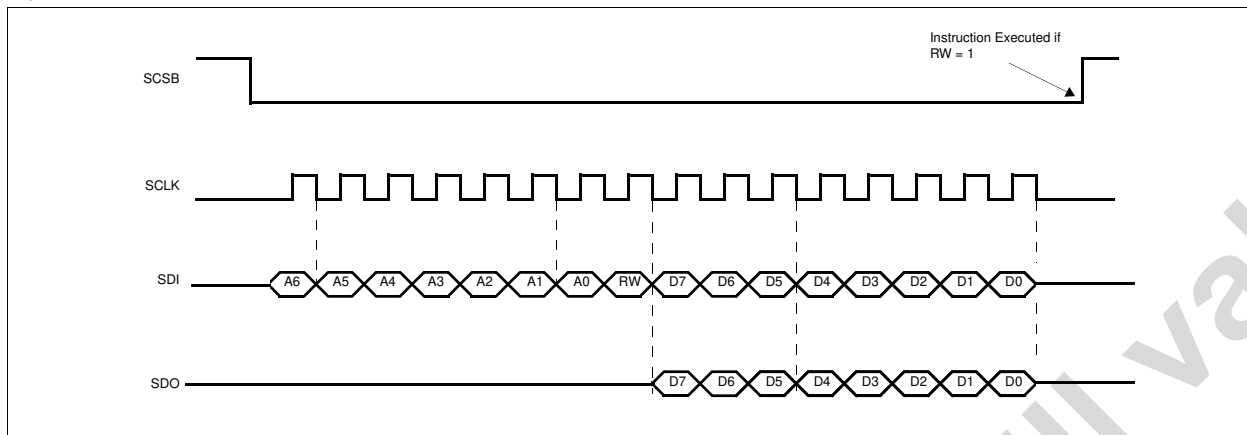

For a read access bit RW (signal SDI) = 1, for a write access bit RW (signal SDI) = 0.

Data is captured at the rising edge of SCLK and written to SDO at the falling edge of SCLK. If the cycle is not completed after the last bit of the addressed cell, the access is continued with next address (address + 1) to allow block transfers. The maximum clock rate is 10MHz.

### 7.8.3 I<sup>2</sup>C Compatible Serial Interface

#### I<sup>2</sup>C Configuration

The AS3604 can be configured as an I<sup>2</sup>C-slave. The AS3604 is able to detect automatically that I<sup>2</sup>C-mode is used when pin SCSB is connected to SDO.

The following pins are used for the I<sup>2</sup>C interface:

- SDI/SDA = I/O Pin
- SCLK /SCK = Input Pin

#### I<sup>2</sup>C Features

- Fast-mode capability (max. SCL-frequency is 400 kHz @ 100pF capacitive load)
- 7-bit addressing mode
- Write formats: Single-Byte-Write, Page-Write
- Read formats: Current-Address-Read, Random-Read, Sequential-Read
- SDA input delay and SCL spike filtering by integrated RC-components

#### I<sup>2</sup>C Slave Addresses

The AS3604 device address is fixed at 82<sub>h</sub> for write commands and 83<sub>h</sub> for read commands.

Figure 29. Complete Data Transfer

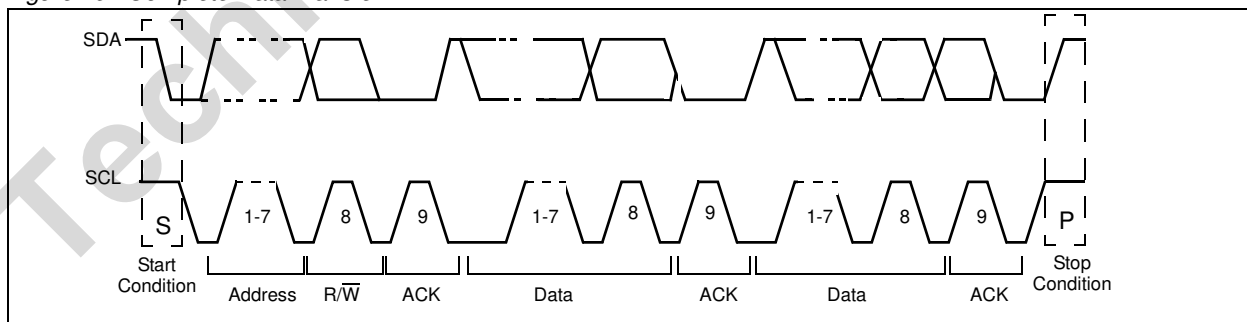

### I<sup>2</sup>C Data Transfer Formats

Definitions used in the serial data transfer format diagrams (Figures 30 - 34) are listed in Table 34.

Table 34. I<sup>2</sup>C Data Transfer Byte Definitions

Symbol	Definition	R/W (AS3604 Slave)	Notes
S	Start condition after stop	R	1 bit
Sr	Repeated start	R	1 bit
DW	Device address for write	R	1000 0010 (82 <sub>h</sub> )
DR	Device address for read	R	1000 0011 (83 <sub>h</sub> )
WA	Word address	R	8 bit
A	Acknowledge	W	1 bit
N	No acknowledge	R	1 bit
reg_data	Register data/write	R	8 bit
data (n)	Register data/read	R	1 bit
P	Stop condition	R	8 bit
WA++	Increment word address internally	R	During acknowledge

Figure 30. I<sup>2</sup>C Byte Write

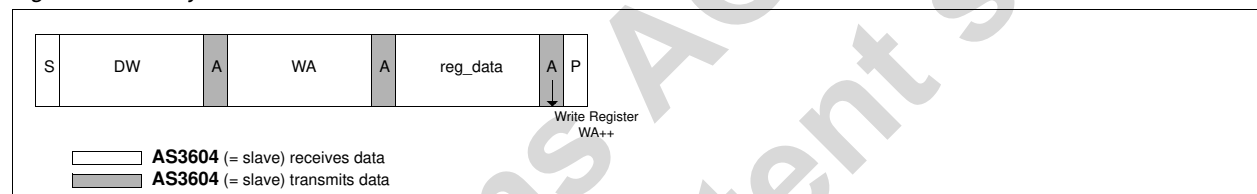
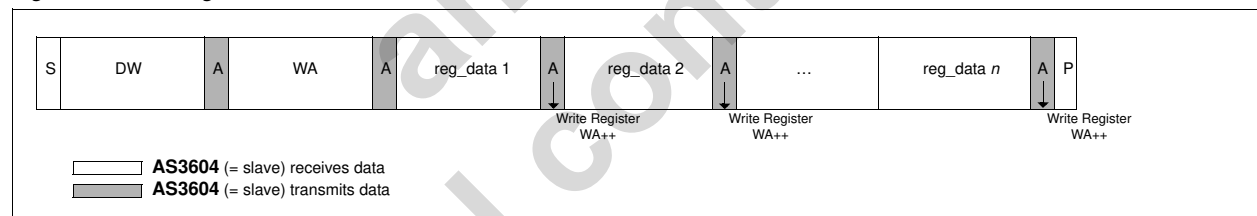

Figure 31. I<sup>2</sup>C Page Write



Byte Write and Page Write formats are used to write data to the slave.

The transmission begins with the START condition, which is generated by the master when the bus is in IDLE state (the bus is free). The device-write address is followed by the word address. After the word address any number of data bytes can be sent to the slave. The word address is incremented internally, in order to write subsequent data bytes on subsequent address locations.

For reading data from the slave device, the master has to change the transfer direction. This can be done either with a repeated START condition followed by the device-read address, or simply with a new transmission START followed by the device-read address, when the bus is in IDLE state. The device-read address is always followed by the 1st register byte transmitted from the slave. In Read Mode any number of subsequent register bytes can be read from the slave. The word address is incremented internally.

The following diagrams show some of the serial read formats supported by the AS3604.

Figure 32. I<sup>2</sup>C Random Read

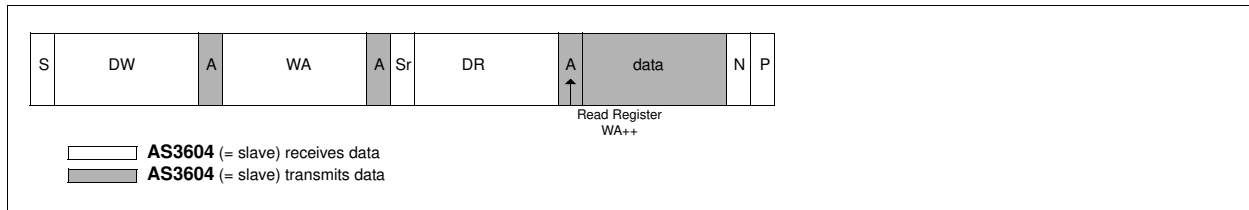

Random Read and Sequential Read are combined formats. The repeated START condition is used to change the direction after the data transfer from the master.

The word address transfer is initiated with a START condition issued by the master while the bus is idle. The START condition is followed by the device-write address and the word address.

In order to change the data direction a repeated START condition is issued on the 1st SCL pulse after the acknowledge bit of the word address transfer. After the reception of the device-read address, the slave becomes the transmitter. In this state the slave transmits register data located by the previous received word address vector. The master responds to the data byte with a not-acknowledge, and issues a STOP condition on the bus.

Figure 33. I<sup>2</sup>C Sequential Read

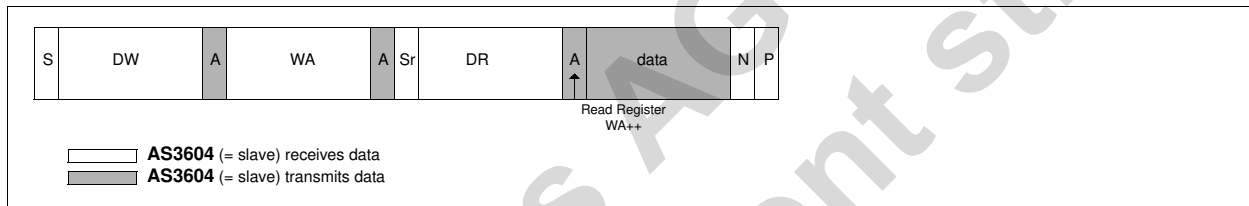

Sequential Read is the extended form of Random Read, as more than one register-data bytes are transferred subsequently. In difference to the Random Read, for a sequential read the transferred register-data bytes are responded by an acknowledge from the master. The number of data bytes transferred in one sequence is unlimited (consider the behavior of the word-address counter). To terminate the transmission the master has to send a not-acknowledge following the last data byte and generate the STOP condition subsequently.

Figure 34. I<sup>2</sup>C Current Address Read

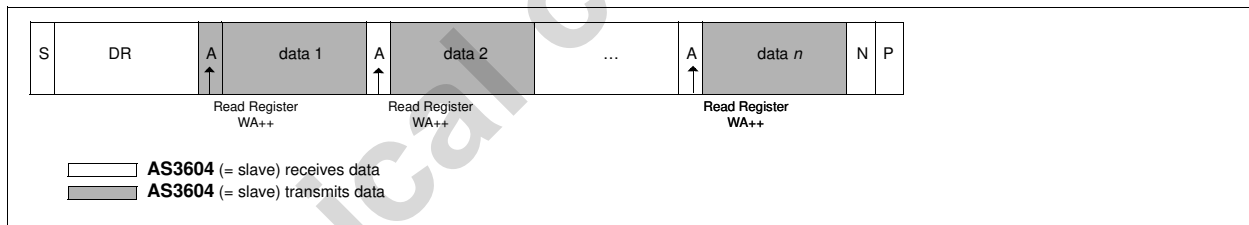

To keep the access time as small as possible, this format allows a read access without the word address transfer in advance to the data transfer. The bus is idle and the master issues a START condition followed by the Device-Read address. Analogous to Random Read, a single byte transfer is terminated with a not-acknowledge after the 1st register byte. Analogous to Sequential Read an unlimited number of data bytes can be transferred, where the data bytes have to be responded with an acknowledge from the master. For termination of the transmission the master sends a not-acknowledge following the last data byte and a subsequent STOP condition.

## 8 Register Map

The AS3604 registers along with their addresses and default values are listed in Table 35. Fields marked N/A are not used; reading these bits may result in 0s or 1s. Always use 0s, when writing to these bits.

**Caution:** Do not write to addresses not listed in Table 35.

Table 35. Register Summary

Register	Addr	Default	B7	B6	B5	B4	B3	B2	B1	B0	
Step Down Voltage/ Test Modes	01	ROM	buck_tm		buck_v						
LDO_RF1 Voltage	02	ROM	N/A			ldo_rf1_v					
LDO_RF2 Voltage	03	ROM	N/A			ldo_rf2_v					
LDO_RF3 Voltage	04	ROM	N/A			ldo_rf3_v					
LDO_RF4 Voltage	05	ROM	N/A			ldo_rf4_v					
LDO_ANA Voltage	06	ROM	ldo_ana1_v			ldo_ana2_v					
LDO_DIG1 Voltage	07	ROM	N/A	dcdc_fb_sel	ldo_dig1_v						
LDO_DIG2 Voltage	08	ROM	N/A	ldo_sim_v	ldo_dig2_v						
Reg Power Ctrl (6ms after start)	09	ROM	N/A		buck_on	ldo_sim_on	ldo_dig2_on	ldo_dig1_on	ldo_ana2_on	ldo_ana1_on	
LDO_RF Switch 6ms (after start) 1	10	ROM	ldo_rf4_on	ldo_rf3_on	ldo_rf2_on	ldo_rf1_on	rf4_sw	rf3_sw	ana2_sw	ana1_sw	
Reg Power Ctrl 6.128ms (after start) 1	11	ROM	N/A		buck_on	ldo_sim_on	ldo_dig2_on	ldo_dig1_on	ldo_ana2_on	ldo_ana1_on	
LDO_RF Switch 6.128ms (after start) 1	12	ROM	ldo_rf4_on	ldo_rf3_on	ldo_rf2_on	ldo_rf1_on	rf4_sw	rf3_sw	ana2_sw	ana1_sw	
Reg Power Ctrl 6.256ms (after start) 1	13	ROM	N/A		buck_on	ldo_sim_on	ldo_dig2_on	ldo_dig1_on	ldo_ana2_on	ldo_ana1_on	
LDO_RF Switch 6.256ms (after start) 1	14	ROM	ldo_rf4_on	ldo_rf3_on	ldo_rf2_on	ldo_rf1_on	rf4_sw	rf3_sw	ana2_sw	ana1_sw	
LDO_GPIO active	15	ROM	ldo_dig2_gpio	ldo_dig1_gpio	ldo_rf4_gpio	ldo_rf3_gpio	Ldo_rf2_gpio	ldo_rf1_gpio	ldo_ana2_gpi o	buck_gpio	
LDO_RF Switch	16	ROM	ldo_rf4_on	ldo_rf3_on	ldo_rf2_on	ldo_rf1_on	rf4_sw	rf3_sw	ana2_sw	ana1_sw	
LDO_AD GPIOx	17	ROM	ldo_dig2_gpio_sel		ldo_dig1_gpio_sel		Ldo_ana2_gpio_sel		ldo_ana1_gpio_sel		
LDO_RF GPIOx	18	ROM	ldo_rf4_gpio_sel		ldo_rf3_gpio_sel		ldo_rf2_gpio_sel		ldo_rf1_gpio_sel		
Reset Timer	19	ROM	N/A		reset_mask_timer			res_timer			
ChargerControl	20	ROM	ChOvEn	Boost	Bypass	Pulse	Li4v2	Fast	BatType	ChEn	
FuelGauge	21	ROM	N/A				CalMod	CalReq	UpdReq	FGEn	
Charger Current and Voltage	22	ROM	ChOv	ChOvH	Bat_v	ConstantCurrent[2:0]			TrickleCurrent[1:0]		
Step Down Config	23	ROM	buck dis_curmin	buck dis_pon	buck_lpo	buck_frequ	buck_4u7	buck_dis_n	buck _nsw_on	Buck _psw_on	
Charge Pump Control Onkey Pulldown	24	ROM	N/A		onkey_pull_d off	cp_freq	N/A	cp_vref	cp_pulsestkip	cp_on	
Step Up DC/DC Control	25	ROM	N/A				stpup_low_cu rr	stpup_freq	stpup_sw_on	stpup_on	
GPIO1 Control	26	ROM	gpio1_out_src		gpio1_invert	gpio1_pulls		gpio1_voltage	gpio1_mode		
GPIO2 Control	27	ROM	gpio2_out_src		gpio2_invert	gpio2_pulls		gpio2_voltage	gpio2_mode		
GPIO3 Control	28	ROM	gpio3_out_src		gpio3_invert	gpio3_pulls		gpio3_voltage	gpio3_mode		
Clock Generation	30	ROM	N/A							ext_clk	
Interrupt Enable	31	ROM	chgov_int_en	chgrmv_int_e n	resume_int_e n	chdet_int_en	onkey_int_en	ovtmp_int_en	eoc_int_en	wdog_int_en	
Interrupt Status	32	NA	chgov_i	chgrmv_i	resume_i	chdet_i	onkey_i	ovtmp_i	eoc_i	wdog_i	
GPIO Signal	33	NA	N/A					gpio3	gpio2	gpio1	
GPIO Frequency Control High Time	34	00h	gpio_h_time								

## Data Sheet

Table 35. Register Summary

Register	Addr	Default	B7	B6	B5	B4	B3	B2	B1	B0	
GPIO Frequency Control Low Time	35	00h	gpio_l_time								
CURR1 value	36	00h	curr1_current								
CURR2 value	37	00h	curr2_current								
CURR3 value	38	00h	curr3_current								
CURR4 value	39	00h	curr4_current								
CURR control	40	00h	curr4_ctrl		curr3_ctrl		curr2_ctrl		curr1_ctrl		
CURR mode	41	00h	N/A				curr4_sw	curr3_sw	curr2_sw	curr1_sw	
CURR GPIO map	42	00h	curr4_gpio		curr3_gpio		curr2_gpio		curr1_gpio		
Audio Control	43	00h	aud_gain				aud_ib_red		aud_lpo	aud_on	
ChargerTiming	44	4Bh	TPOFFMAX[1:0]		TPOFF[2:0]			TPON[2:0]			
References Control	45	00h	N/A			low_power_gpio_pol	low_power_gpio		low_power_gpio_on	low_power_on	
Watchdog Control	46	02h	N/A			wtdg_trigger	wtdg_gpio_input		wtdg_res_on	wtdg_on	
Watchdog_min Timer	47	00h	wtdg_min_timer								
Watchdog_max Timer	48	FFh	wtdg_max_timer								
Watchdog Software Signal	49	00h	N/A								wtdg_sw_sig
ChargerStatus	53	NA	Bypass	NoBat	EOC	CVM	Trickle	IntReg	ChAct	ChDet	
DeltaChargeMSB	54	NA	sign	214	213	212	211	210	29	28	
DeltaChargeLSB	55	NA	27	26	25	24	23	22	21	20	
lapsedTimeMSB	56	NA	215	214	213	212	211	210	29	28	
ElapsedTimeLSB	57	NA	27	26	25	24	23	22	21	20	
Reset Control	58	0h	N/A	tmp_pwr_loss	reset_reason			on_input	power_off	force_reset	
Overtemperature Control	59	00h	N/A				rst_ov_temp_140	ov_temp_140	ov_temp_110	temp_pmc_on	
Boot_status	60	NA	N/A				rom_valid	rom_adr			
ASIC ID 1	61	33h	0	0	1	1	0	0	1	1	
ASIC ID 2	62	50h	Rev								
Audio Control 2	65	0h	N/A				aud_pullawn		aud_overcurr	aud_stereo	
ChargerConfig	66	0h	N/A	AutoChgTerm	CVMTst	DisOWB	DisBDet	DisHyst	Wide	N/A	
PreCurDAC	67	00h	27	26	25	24	23	22	21	20	

Read-Only Bit



Read/Write Bit

1. Reading registers 10 -14 will always return 00h. These registers are only used during startup sequencing of the respective LDOs. The final sequence in register 14 can be read in register 09 after the boot sequence is completed.

## 9 Pinout and Packaging

### 9.1 Pin Descriptions

Table 36. Pin Type Definitions

Pin Type	Description
DI	Digital Input
DO	Digital Output
DIO	Digital Input/Output
DIO_5	Digital Input/Output with Selectable Supply (V5_6 or VSS)
OD	Open Drain - the device can only pulldown this pin
AIO	Analog Pin
AI	Analog Input
AO	Analog Output
S	Supply Pin
GND	Ground Pin

Table 37. Pinlist QFN48

Pin	Name	Type	Description
1	V5_6	AIO	Output voltage of the Charge Pump; if used, connect a ceramic capacitor of 1 $\mu$ F ( $\pm$ 20%) or 2.2 $\mu$ F (+100%/-50%).
2	CAPP	AIO	Flying capacitor of the Charge Pump; if used, connect a ceramic capacitor of 330nF ( $\pm$ 20%) to this pin.
3	CAPN	AIO	Flying capacitor of the Charge Pump; if used connect a ceramic capacitor of 330nF ( $\pm$ 20%) to this pin.
4	VANA_1	AO	Output voltage of Analog LDO VANA_1; if the Charge Pump or this LDO is used, connect a ceramic capacitor of 1 $\mu$ F ( $\pm$ 20%) or 2.2 $\mu$ F (+100%/-50%).
5	VBAT_1	S	Supply pin for Analog LDOs VANA_1 and VANA_2; can be connected to VBAT or separate supply (3.0-5.5V).
6	VANA_2	AO	Output voltage of one of Analog LDO VANA_2; if used, connect a ceramic capacitor of 1 $\mu$ F ( $\pm$ 20%) or 2.2 $\mu$ F (+100%/-50%).
7	VRF_2	AO	Output voltage of RF LDO VRF_2; can be used as high-side switch, if used as LDO, connect a ceramic capacitor of 1 $\mu$ F ( $\pm$ 20%) or 2.2 $\mu$ F (+100%/-50%).
8	VBAT_4	S	Supply pad for RF-LDOs VRF_1 and VRF_2 and internal LDO; can be connected to VBAT or separate supply (3.0-5.5V).
9	VRF_1	AO	Output voltage of RF LDO VRF_1; can be used as high-side switch, if used as LDO, connect a ceramic capacitor of 1 $\mu$ F ( $\pm$ 20%) or 2.2 $\mu$ F (+100%/-50%).
10	RESET	DIO/OD	Bidirectional RESET pin; add an external pullup resistor to pin VANA_1.
11	SDO	DO	SPI digital output in SPI mode; connect to pin SCSB in I <sup>2</sup> C mode.
12	SDI/SDA	DI	SPI digital input in SPI mode; SDA input/output in I <sup>2</sup> C mode.
13	SCLK/SCK	DI	SPI clock input in SPI mode; SCK input in I <sup>2</sup> C mode.
14	SCSB	DI	SPI chip-select in SPI mode; connect to pin SDO in I <sup>2</sup> C mode.
15	ISENSP	AI	Positive sensing input voltage for the external charging current shunt resistor.
16	ISENSN	AI	Negative sensing input voltage for the external charging current shunt resistor.
17	VRF_3	AO	Output voltage of RF LDO VRF_3; can be used as high-side switch, if used as LDO, connect a ceramic capacitor of 1 $\mu$ F ( $\pm$ 20%) or 2.2 $\mu$ F (+100%/-50%).
18	VBAT_5	S	Supply pin for Charger, RF LDOs VRF_3 and VRF_4. Always connect to VBAT.
19	VRF_4	AO	Output voltage of RF LDO VRF_4; can be used as high-side switch, if used as LDO, connect a ceramic capacitor of 1 $\mu$ F ( $\pm$ 20%) or 2.2 $\mu$ F (+100%/-50%).
20	VCHARGER	AI	High voltage input coming from the Battery Charger; if the Battery Charger is used, connect a ceramic capacitor of 1 $\mu$ F.

Table 37. Pinlist QFN48 (Continued)

Pin	Name	Type	Description
21	VGATE	AO	Control pin for the external battery charger MOSFET transistor.
22	V2_5	AO	Output voltage of low power LDO V2_5; always connect a ceramic capacitor of 1 $\mu$ F ( $\pm$ 20%) or 2.2 $\mu$ F (+100%/-50%); do not load this pin during startup.
23	RBIAS	AIO	External resistor; always connect a resistor of 220k $\Omega$ ( $\pm$ 1%) to ground. <b>Caution:</b> Do not load this pin.
24	RPROGRAM	AIO	External resistor for selecting Boot ROM address; audio input in testmode.
25	ON	DI	Input pin to startup the AS3604 (power on); internal pulldown. Supply pin for Zenerzap programming voltage (for internal use only).
26	CREF	AIO	Bypass capacitor for the internal voltage reference; always connect a capacitor of 100nF. <b>Caution:</b> Do not load this pin.
27	GND_SENSE	AIO	Sensitive GND for Bandgap Voltage Reference.
28	AOUT_L	AO	Audio Amplifier left-channel output.
29	AOUT_R	AO	Audio Amplifier right-channel output.
30	VBAT_3	S	Supply pin for Step-Up Converter, Current Sinks, and Audio Amplifier; always connect to VBAT.
31	AGND	AIO	Audio Amplifier reference GND; if the Audio Amplifier is used, connect a capacitor of 100nF ( $\pm$ 10%) to this pin. <b>Caution:</b> Do not connect directly to VSS.
32	CURR4	AI	Analog current sink input (designed for buzzer).
33	CURR3	AI	Analog current sink input (designed for vibrator).
34	CURR2	AI	Analog current sink input (designed for (white LEDs).
35	CURR1	AI	Analog current sink input (designed for white LEDs); also used as input for the Step Up DC/DC Converter.
36	STEPUP	AIO	Step Up DC/DC Converter output pin; can also be used as a ground switch.
37	AIN_R	AI	Audio Amplifier right-channel input; sense output in test mode.
38	AIN_L	AI	Audio Amplifier left-channel input; sense output in test mode.
39	VDIG_2	AO	Output voltage of Digital LDO VDIG_2; if used, connect a ceramic capacitor of 100nF ( $\pm$ 20%).
40	VBUCK	AI	Supply pin for Digital LDOs VDIG_1 and VDIG_2; If the Step Down DC/DC converter is used as pre-regulator, connect this pin to the output of the DC/DC converter. If Step Down DC/DC pre-regulator is not used, this pin can be connected to VBAT or a separate supply (1.0-5.5V).
41	VDIG_1	AO	Output voltage of Digital LDO VDIG_1; if used, connect a ceramic capacitor of 100nF ( $\pm$ 20%).
42	VBAT_6	S	Supply pin for digital LDO VDIG_1. Connect to VBAT.
43	GPIO3	DIO_5	General purpose switchable 5V input/output.
44	GPIO2	DIO_5	General purpose switchable 5V input/output.
45	GPIO1	DIO_5	General purpose switchable 5V input/output.
46	VSIM	AO	Output voltage of LDO VSIM; if used, connect a ceramic capacitor of 100nF ( $\pm$ 20%).
47	VBAT_2	S	Supply pin for the Step Down DC/DC Converter and LDO VSIM; always connect to VBAT.
48	LX	AO	Step Down DC/DC Converter output.
49	VSS	Vss	Ground pad (QFN48: exposed paddle).



## 9.2 Package Drawings and Markings

Figure 35. QFN 48 – 6x6mm with Exposed Paddle

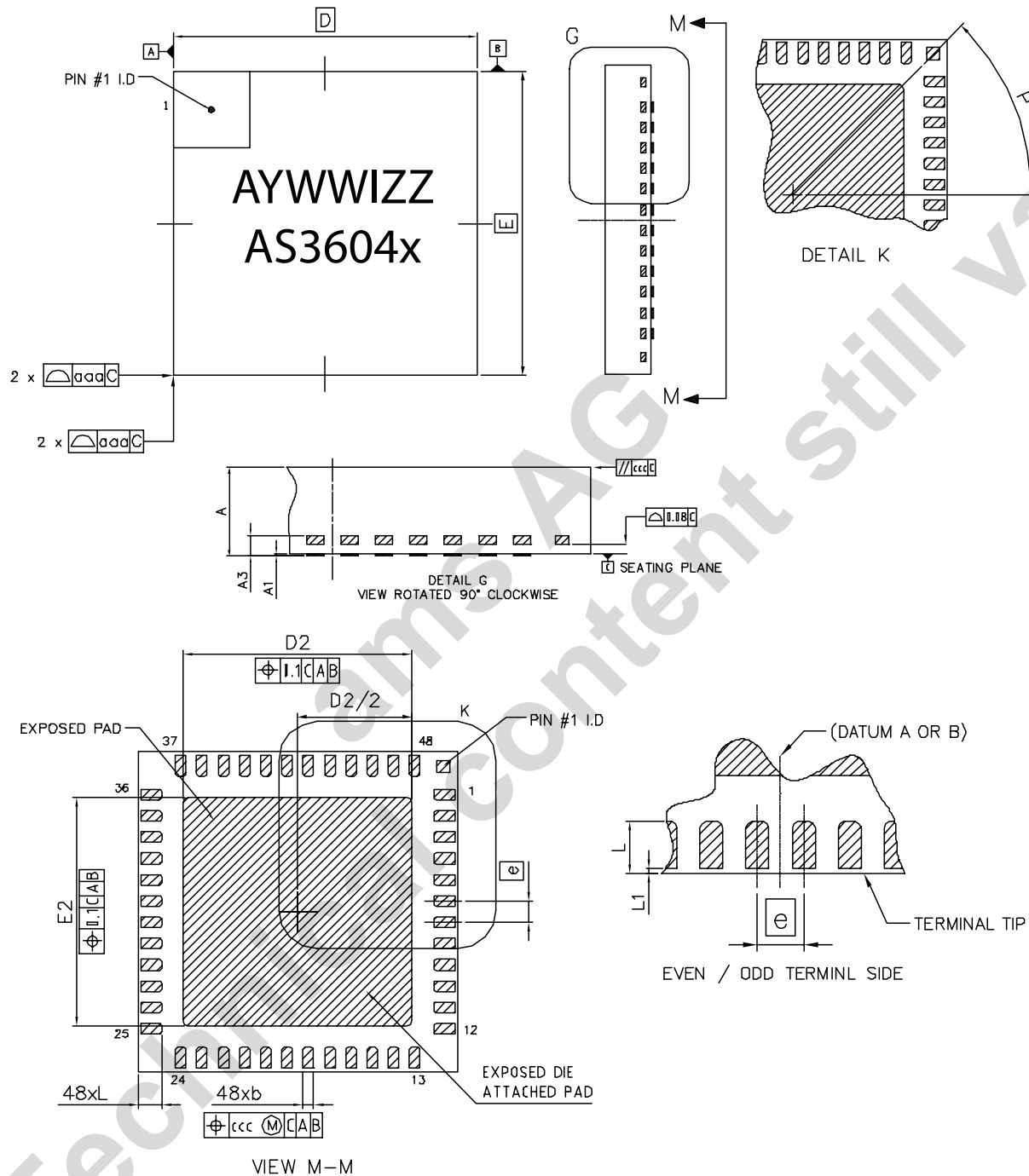

EDEC Package Outline Standard: MO-220 VHHD-5 – Lead Finish: 100% Sn "Matte Tin".

**Marking:** AYWWIZZ      A: Pb-Free Identifier  
    Y: Last Digit of Manufacturing Year  
    WW: Manufacturing Week  
    I: Plant Identifier  
    ZZ: Traceability Code

Symbol	Min	Nom	Max
A	0.80	0.85	0.90
A1	0.203REF		
A3	0.00		0.05
b	0.18	0.20	0.25
D	6.00BSC		
E	6.00BSC		
D2	4.20		4.40
E2	4.20		4.40
e	0.40BSC		
L	0.40	0.45	0.50
L1			0.10
P	45°BSC		
aaa		0.05	
ccc		0.10	

**Notes:**

1. Dimensioning and tolerancing conform to *ASME Y14.5M-1994*.
2. All dimensions are in millimeters; angles are in degrees.
3. Dimension b applies to metallic terminals and is measured between 0.25 and 0.30mm from the terminal top. Dimension L1 represents the terminal fullback from the package edge. Up to 0.1mm is acceptable.
4. Coplanarity applies to the exposed heat slug as well as the terminal.
5. Radius on terminal is optional.

## 10 External Parts List

The recommended specifications for external components (refer to Figure 1 on page 2 and Figure 2 on page 3) are listed in Table 38.

Table 38. External Parts Specification

Part	Min.	Typ.	Max.	Tol. Min.	Rating Min.	Remarks	Package Min.
C1	1 $\mu$ F		4.7 $\mu$ F	$\pm 20\%$	25V	Ceramic, X5R, X7R (Step-Up)	1206
C2		330nF		$\pm 20\%$	6.3V	Ceramic, X5R (Charge Pump)	0603
C3	1 $\mu$ F		4.7 $\mu$ F	$\pm 20\%$	6.3V	Ceramic, X5R (V5_6)	0603
C4	1 $\mu$ F		4.7 $\mu$ F	$\pm 20\%$	6.3V	Ceramic, X5R (VANA_1)	0603
C5		1 $\mu$ F		$\pm 20\%$	6.3V	Ceramic, X5R (VBAT_1)	0603
C6	1 $\mu$ F		4.7 $\mu$ F	$\pm 20\%$	6.3V	Ceramic, X5R (VANA_2)	0603
C7		22 $\mu$ F		$\pm 20\%$	6.3V	Ceramic, X5R (V2_5)	1206
C8	1 $\mu$ F		4.7 $\mu$ F	$\pm 20\%$	6.3V	Ceramic, X5R (VRF_1)	0603
C9		1 $\mu$ F		$\pm 20\%$	6.3V	Ceramic, X5R (VBAT_4)	0603
C10	1 $\mu$ F		4.7 $\mu$ F	$\pm 20\%$	6.3V	Ceramic, X5R (VRF_2)	0603
C11	1 $\mu$ F		4.7 $\mu$ F	$\pm 20\%$	6.3V	Ceramic, X5R (VRF_3)	0603
C12		1 $\mu$ F		$\pm 20\%$	6.3V	Ceramic, X5R (VBAT_5)	0603
C13	1 $\mu$ F		4.7 $\mu$ F	$\pm 20\%$	6.3V	Ceramic, X5R (VRF_4)	0603
C14	1 $\mu$ F		4.7 $\mu$ F	$\pm 20\%$	6.3V	Ceramic, X5R (VDIG_1)	0603
C15	1 $\mu$ F		4.7 $\mu$ F	$\pm 20\%$	6.3V	Ceramic, X5R (VDIG_2)	0603
C16		1 $\mu$ F		$\pm 20\%$	6.3V	Ceramic, X5R (VBAT_2)	0603
C18		10 $\mu$ F		$\pm 20\%$	6.3V	Ceramic, X5R (VBUCK)	
C19		100nF		$\pm 20\%$	6.3V	Ceramic, X5R (VSIM)	0402
C20		100 $\mu$ F		$\pm 20\%$	6.3V	Tantalum; L Stereo Decoupling Cap.	
C21		100 $\mu$ F		$\pm 20\%$	6.3V	Tantalum; R Stereo Decoupling Cap.	
C22		1 $\mu$ F		$\pm 20\%$	6.3V	Ceramic, X5R (VBAT_4)	0603
C23		100nF		$\pm 20\%$	6.3V	Ceramic, X5R (Decoupling, AIN_L)	0402
C24		100nF		$\pm 20\%$	6.3V	Ceramic, X5R (Decoupling, AIN_R)	0402
C25		100nF		$\pm 20\%$	6.3V	Ceramic, X5R (AGND)	0402
C26	1 $\mu$ F		4.7 $\mu$ F	$\pm 20\%$	6.3V	Ceramic, X5R (VCHARGER)	0603
C27	10 $\mu$ F			$\pm 20\%$	6.3V	X5R; all VBAT Caps. Combined	0603
C28		1 $\mu$ F		$\pm 20\%$	6.3V	Ceramic, X5R (ISense)	0402
C29		100nF		$\pm 20\%$	6.3V	Ceramic, X5R (CREF)	0402
C30	1 $\mu$ F		4.7 $\mu$ F	$\pm 20\%$	6.3V	Ceramic, X5R (VBUCK)	0603
R1		2k		$\pm 1\%$		VGATE Pullup Resistor	0201
R2		4.7k		$\pm 1\%$		ISENSP Series Resistor	0201
R3		4.7k		$\pm 1\%$		ISENSN Series Resistor	0201
R4	25m	50m	100m	$\pm 1\%$		Shunt resistor	0603
R7				$\pm 5\%$			
R5		100k		$\pm 10\%$		Reset Pullup Resistor	0201
R6		220k		$\pm 1\%$		Bias Resistor	0201
R7		0 10k 20k 39k 82k 160k 330k Inf		$\pm 5\%$		Select ROM Bank 7 Select ROM Bank 6 Select ROM Bank 5 Select ROM Bank 4 Select ROM Bank 3 Select ROM Bank 2 Select ROM Bank 1 Select ROM Bank 0	0201
L1		22 $\mu$ H		$\pm 20\%$		Recommended type: Coiltronics SD-12-220	
L2		2.2 $\mu$ H		$\pm 20\%$		Recommended type: Coiltronics SD-12-2R2	
D1		MBR0520 or similar				Schottky Diode; ONSEMI, IR	SOD123
D2		xx4148				Universal Diode	
Q1		Si3441 or similar				PMOS Charger Transistor; VISHAY	

## 11 Ordering Information

Device ID	Marking	Package Type	Delivery Form*	Description
AS3604A-ZQFP	AS3604A	QFN48 6x6mm	Tape and Reel (in dry pack)	Package Size = 6x6x0.85mm; Pitch = 0.4mm; Pb-Free
AS3604B-ZQFP	AS3604B	QFN48 6x6mm	Tape and Reel (in dry pack)	Package Size = 6x6x0.85mm; Pitch = 0.4mm; Pb-Free

### Where:

A/B = Revision A or B

Z = Temperature Range: -30 to +70 °C

QF = QFN Package

P = Delivery Form Tape and Reel in Dry Pack

\* Dry pack sensitivity level = 3 in accordance with *IPC/JEDEC J-STD-033A*.

## Copyrights

Copyright © 1997-2009, austriamicrosystems AG, Schloss Premstaetten, 8141 Unterpemstaetten, Austria-Europe. Trademarks Registered ®. All rights reserved. The material herein may not be reproduced, adapted, merged, translated, stored, or used without the prior written consent of the copyright owner.

All products and companies mentioned are trademarks or registered trademarks of their respective companies.

## Disclaimer

Devices sold by austriamicrosystems AG are covered by the warranty and patent indemnification provisions appearing in its Term of Sale. austriamicrosystems AG makes no warranty, express, statutory, implied, or by description regarding the information set forth herein or regarding the freedom of the described devices from patent infringement. austriamicrosystems AG reserves the right to change specifications and prices at any time and without notice. Therefore, prior to designing this product into a system, it is necessary to check with austriamicrosystems AG for current information. This product is intended for use in normal commercial applications. Applications requiring extended temperature range, unusual environmental requirements, or high reliability applications, such as military, medical life-support or life-sustaining equipment are specifically not recommended without additional processing by austriamicrosystems AG for each application. For shipments of less than 100 parts the manufacturing flow might show deviations from the standard production flow, such as test flow or test location.

The information furnished here by austriamicrosystems AG is believed to be correct and accurate. However, austriamicrosystems AG shall not be liable to recipient or any third party for any damages, including but not limited to personal injury, property damage, loss of profits, loss of use, interruption of business or indirect, special, incidental or consequential damages, of any kind, in connection with or arising out of the furnishing, performance or use of the technical data herein. No obligation or liability to recipient or any third party shall arise or flow out of austriamicrosystems AG rendering of technical or other services.

## Contact Information

### Headquarters

austriamicrosystems AG  
A-8141 Schloss Premstaetten, Austria

Tel: +43 (0) 3136 500 0  
Fax: +43 (0) 3136 525 01

For Sales Offices, Distributors and Representatives, please visit:

<http://www.austriamicrosystems.com/contact>

*austriamicrosystems* – a leap ahead