

| CODE | DIM "M" MATING LENGTH | CONTACT TYPE |
|------|-----------------------|--------------|
| PC | [N/A] | POWER |
| G | [6.86] | SIGNAL |
| HA | [N/A] | HOLD-DOWN |

| | | | | | | | | | | | | |
|---------------|---------------------------------------|-------|-------|----------|-------------|------------------------|----------------|----------|-----------|----------|-------|-----|
| spec ref | See Notes | | | dr | Ruan MT | 2013/09/27 | projection | MM ←→ | size | A4 | scale | 1:1 |
| tolerance std | TOLERANCES UNLESS OTHERWISE SPECIFIED | | | eng | Ruan MT | 2013/10/15 | | | ecn no | - | | |
| See Notes | | | | chr | - | - | | | rel level | Released | | |
| surface ✓ | linear | 0.X | ±0.50 | FCI | www.fci.com | title | 4P+8S+6P | dwg no | 51952-264 | rev | A | |
| | | 0.XX | ±0.25 | | | | | | | | | |
| | | 0.XXX | ±0.10 | | | | | | | | | |
| | angular | 0° | ±2° | cat. no. | &model_name | Product - Customer Drw | sheet 1 of 4 | | | | | |



Copyright FCI.

PRODUCT NUMBER

51952-264__
NOTE 3

DIM "M" ±0.25

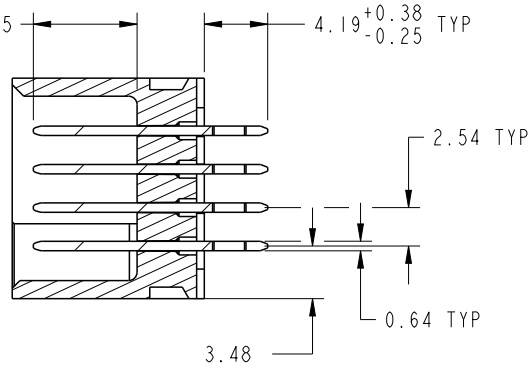

SECTION A-A
SCALE 2:1

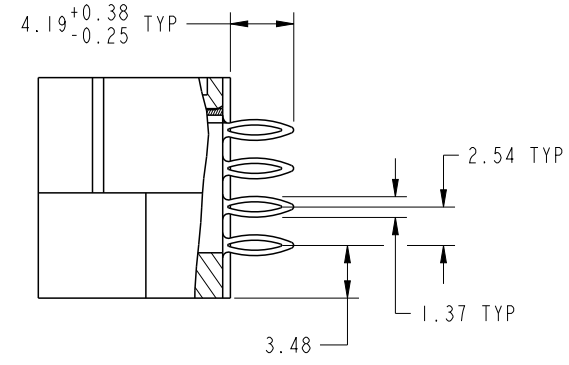

SECTION B-B
SCALE 2:1

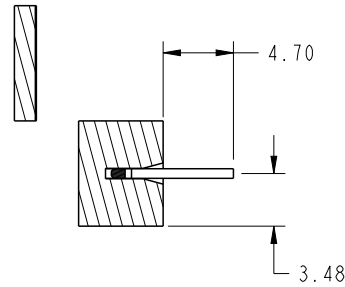

SECTION C-C
SCALE 2:1



| | | | | | | | | | |
|-------------|----------------|------------|----------------|-------------|-----------|------------------------|-------|--------------|--|
| dr | Ruan MT | 2013/09/27 | projection | MM | size | A4 | scale | 1:1 | |
| eng | Ruan MT | 2013/10/15 | | | ecn no | - | | | |
| chr | - | - | | | rel level | Released | | | |
| appr | Pei-Ming Zheng | 2013/10/15 | product family | PwrBlade | rev | A | | | |
| | | title | | 4P+8S+6P | | dwg no | | 51952-264 | |
| www.fci.com | | cat. no. | | &model_name | | Product - Customer Drw | | sheet 2 of 4 | |

PRODUCT NUMBER

51952-264__
NOTE 3

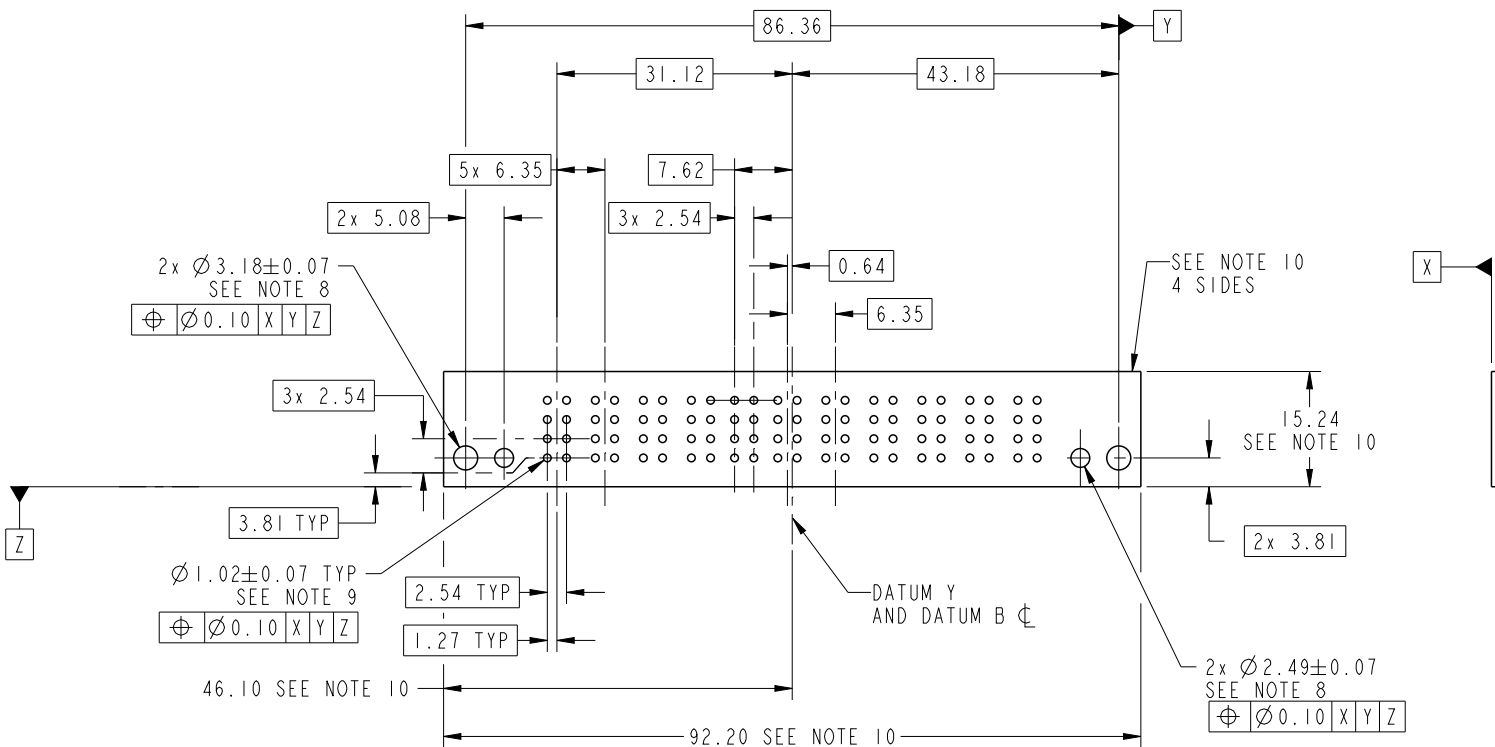

RECOMMENDED PCB LAYOUT

| | | | | | | | | |
|-------------|----------------|-------------|------------------------|----------|--------------|----------|-------|-----|
| dr | Ruan MT | 2013/09/27 | projection | MM | size | A4 | scale | 1:1 |
| eng | Ruan MT | 2013/10/15 | | | ecn no | - | | |
| chr | - | - | | | | | | |
| appr | Pei-Ming Zheng | 2013/10/15 | product family | PwrBlade | rel level | Released | | |
| | title | 4P+8S+6P | | dwg no | 51952-264 | | rev | A |
| www.fci.com | cat. no. | &model_name | Product - Customer Drw | | sheet 3 of 4 | | | |



PRODUCT NUMBER

51952-264__
NOTE 3

NOTES:

1. DIMENSIONS AND TOLERANCES ARE IN ACCORDANCE WITH ASME Y14.5M, 1994 UNLESS OTHERWISE SPECIFIED.

CONNECTOR NOTES:

- ② HOUSING MATERIAL: UL 94 V-0 GLASS FILLED HIGH-TEMP THERMOPLASTIC
POWER CONTACT MATERIAL: COPPER ALLOY
SIGNAL PIN MATERIAL: COPPER ALLOY
- 3. SEE ITEM 3 & 4 IN PRINT 10064183 FOR PLATING SPEC OF 51952-264 AND 51952-264LF RESPECTIVELY.

④ MANUFACTURER'S NAME, DATE CODE AND OPTIONAL P/N TO APPEAR ON THIS SURFACE. THE MARK CAN BE OMITTED IF THERE IS NOT ENOUGH SPACE ON THIS SURFACE.

5. PRODUCT SPECIFICATION GS-12-149.
APPLICATION SPECIFICATION BUS-20-067.

6. PACKAGED IN TRAYS.

PCB NOTES:

- 7. ALL HOLE DIAMETERS ARE FINISHED HOLE SIZE.
- 8. MOUNTING HOLES, WHERE APPLICABLE, ARE UNPLATED.

⑨ $\varnothing 1.151 \pm 0.025$ DRILLED HOLES PLATED WITH 0.008 MIN SnPb OR Sn OVER .001 [0.03] TO 0.08 Cu PLATING TO ACHIEVE $\varnothing 1.02 \pm 0.07$ HOLE.

⑩ CONNECTOR KEEP-OUT ZONE.

11. FOR PRESS FIT APPLICATION USE FCI CAM TOOL 430169-XXX.



Copyright FCI.

| | | | | | | | | |
|-------------|----------------|-------------|------------------------|----------|--------------|----------|-------|-----|
| dr | Ruan MT | 2013/09/27 | projection | MM | size | A4 | scale | 1:1 |
| eng | Ruan MT | 2013/10/15 | | | ecn no | - | | |
| chr | - | - | | | | | | |
| appr | Pei-Ming Zheng | 2013/10/15 | product family | PwrBlade | rel level | Released | | |
| | title | 4P+8S+6P | | dwg no | 51952-264 | | rev | A |
| www.fci.com | cat. no. | &model_name | Product - Customer Drw | | sheet 4 of 4 | | | |