

REV.	DESCRIPTION	DATE	APPROVED
A	Engineering Release	07/31/15	J. C.
B	Added Color Options, Sheet #2	01/25/16	J. C.

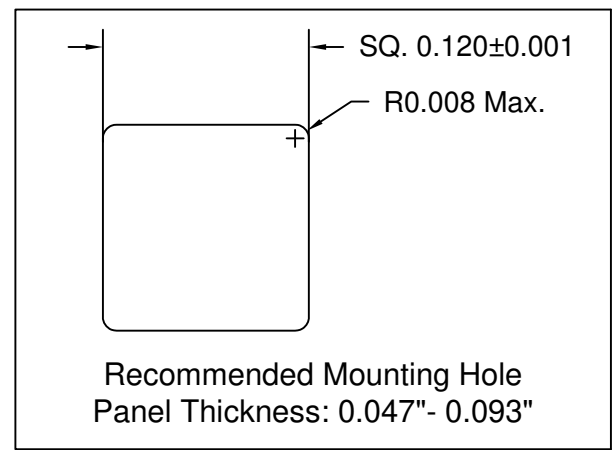

Part No.	X = Body Length
PLPQ3-100-FF	0.100 ( 2.5mm )
PLPQ3-125-FF	0.125 ( 3.2mm )
PLPQ3-188-FF	0.188 ( 4.8mm )
PLPQ3-250-FF	0.250 ( 6.4mm )
PLPQ3-313-FF	0.313 ( 7.9mm )
PLPQ3-375-FF	0.375 ( 9.5mm )
PLPQ3-500-FF	0.500 ( 12.7mm )
PLPQ3-3MM-FF	3mm ( 0.118" )
PLPQ3-4MM-FF	4mm ( 0.157" )
PLPQ3-5MM-FF	5mm ( 0.197" )
PLPQ3-6MM-FF	6mm ( 0.236" )
PLPQ3-7MM-FF	7mm ( 0.276" )
PLPQ3-8MM-FF	8mm ( 0.315" )
PLPQ3-9MM-FF	9mm ( 0.354" )
PLPQ3-10MM-FF	10mm ( 0.394" )

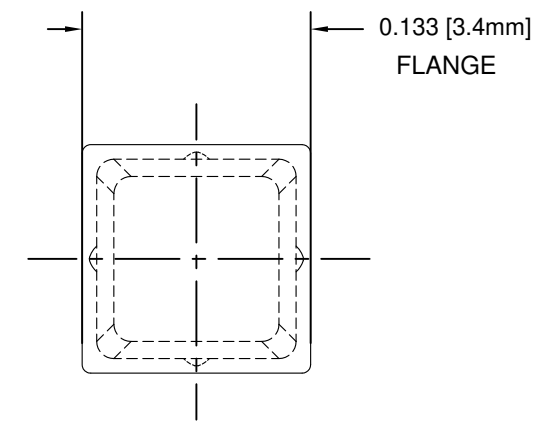
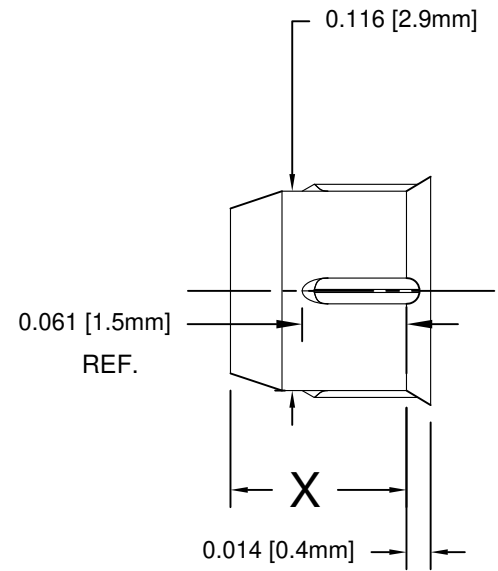
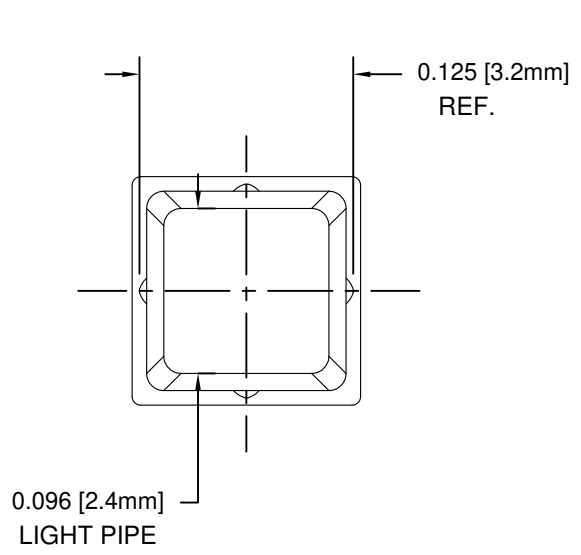
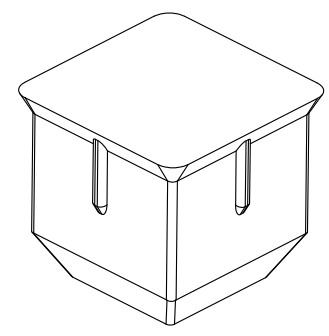

STANDARD TOLERANCE (UNLESS OTHERWISE SPECIFIED)		BIVAR®	
DECIMALS	ANGULAR	4 THOMAS, IRVINE, CA. 92618	
.X ± .1	X° ± 1°	TEL.: (949) 951-8808 FAX: (949) 951-3974	
.XX ± .01		<b>TITLE:</b> SQUARE LIGHT PIPE, FLUSH MOUNT, 3mm	
.XXX ± .005		<b>PART NO:</b> PLPQ3-XXX-FF	
DESIGNED: <b>Brian Oliver</b>	DATE: <b>04/24/15</b>	REVISION: <b>B</b>	
CHECKED: <b>Alex Wright</b>	DATE: <b>04/24/15</b>	<b>CAGE CODE : 32559</b>	<b>SHEET # 1 OF 2</b>
CAD GENERATED DOCUMENT. DO NOT MEASURE DRAWING.			

- 2. MATERIAL: POLYCARBONATE, 94V-0, CLEAR
- 1. GENERAL SPECIFICATIONS: BIVAR MOLDED COMPONENT SPECIFICATION BV00-E101 and BSMC-1001.

**OTHER AVAILABLE COLORS**

\* SEE TABLE FOR ORDERING INFORMATION

REV.	DESCRIPTION	DATE	APPROVED
	SEE SHEET #1		

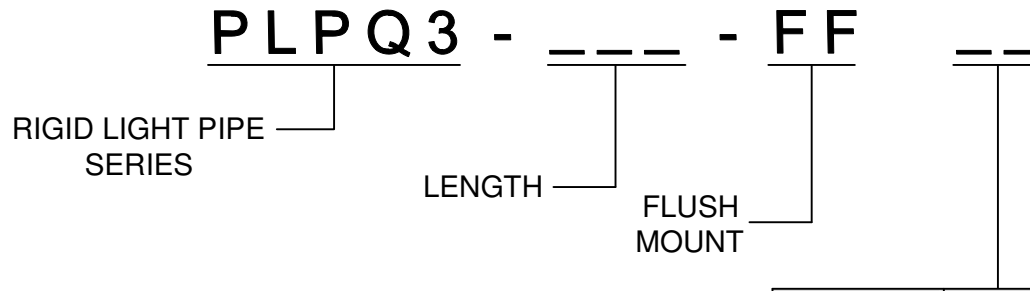

COLOR	Order Code
BLUE	BE
BLACK	BK
GREEN	GN
GRAY	GY
RED	RD
YELLOW	YW

NOTE: LEAVE ORDER CODE BLANK IF NO COLOR IS DESIRED.

3. PARTS ARE DYED TO COLOR UPON REQUEST.

STANDARD TOLERANCE ( UNLESS OTHERWISE SPECIFIED ) DECIMALS                      ANGULAR		<b>BIVAR</b> <sup>®</sup> 4 THOMAS, IRVINE, CA. 92618 TEL: (949) 951-8808    FAX: (949) 951-3974	
			
DESIGNED: <b>K. Aukshunas</b>	DATE: <b>01/25/16</b>	<b>TITLE:</b> SQUARE LIGHT PIPE, FLUSH MOUNT, 3mm	<b>REVISION:</b> <b>B</b>
CHECKED: <b>J. Chiang</b>	DATE: <b>01/25/16</b>	<b>PART NO:</b> PLPQ3-XXX-FF	<b>SHEET # 2 OF 2</b>
<small>CAD GENERATED DOCUMENT. DO NOT MEASURE DRAWING.</small>			