

- NOTES:
- MATERIALS AND FINISHES(PLATING THICKNESS IN MICRO-INCHES):
 SHELL - BRASS(C2680R-0, T0.15), Au (2 MIN) OVER Ni (35-190MIN.) PLATING.
 A-PIN(MOVING) -STAINLESS STEEL (SUS301R-EH,T0.08), Au(5 MIN) OVER Ni (35-150) PLATING
 B-PIN(FIXED) -PHOSPHOR BRONZE (C5191R-H,T0.10), Au(5 MIN) OVER Ni (35-150) PLATING
 MOLD - LCP E5006L
 - ELECTRICAL:
 A. IMPEDANCE: 50 OHM
 B. FREQUENCY RANGE: DC - 6 GHz
 C. VSWR(RETURN LOSS): 1.4 MAX.
 D. DIELECTRIC WITHSTANDING VOLTAGE: 1 MIN. AC300V VRMS
 - MECHANICAL:
 A. DURABILITY: 500 CYCLES MIN.
 B. TEMPERATURE RANGE: -40°C TO +85°C
 - PACKAGING:
 A. TAPE & REEL

THIRD ANGLE PROJ.

REVISIONS				
REV	DESCRIPTION	DATE	ECO	APPR
A	RELEASE TO MFG	2/18/09	47444	TRC
B	DOC ERROR TO CORRECT PIN MATERIAL, .1 WAS .01 DWV WAS 100V VRMS, LOW TEMP WAS -35°C ADDED TAPE AND REEL DRAWING	9/18/14	50156	EW
C	UPDATED PCB PCB PATTERN: 2.7 WAS 3.4, 2.7 WAS 2.65, 0.85 WAS 1.25, 0.75 WAS 1.05, THE OTHERS SEE SHEET 3 FOR DETAILS	11/13/14	50216	

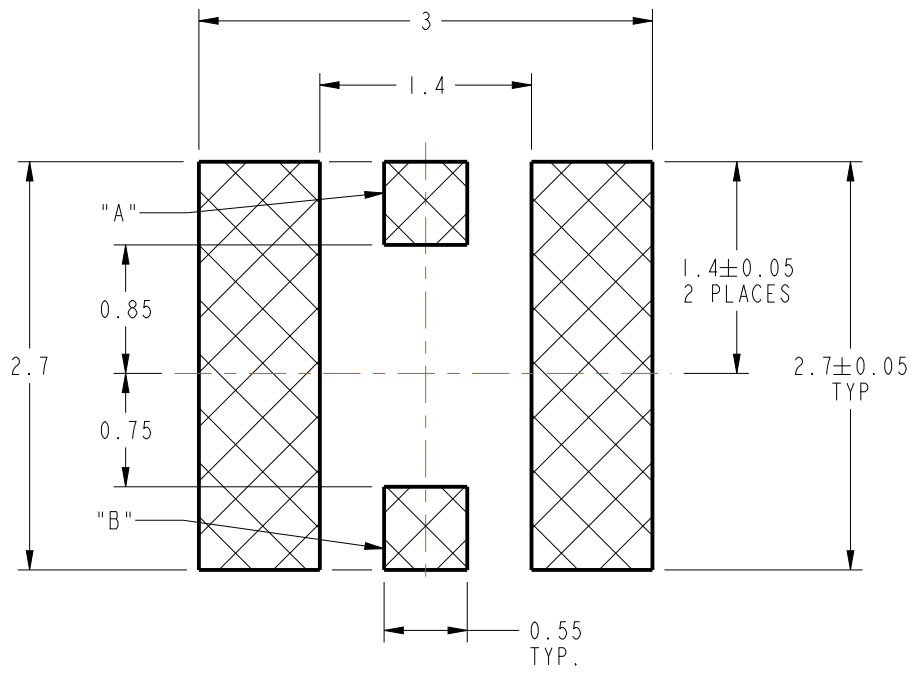

RECOMMENDED PCB PATTERN

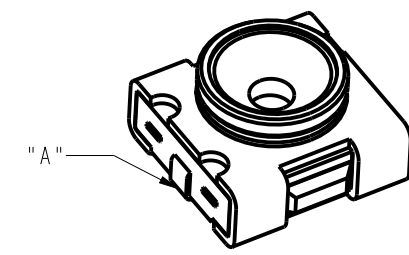
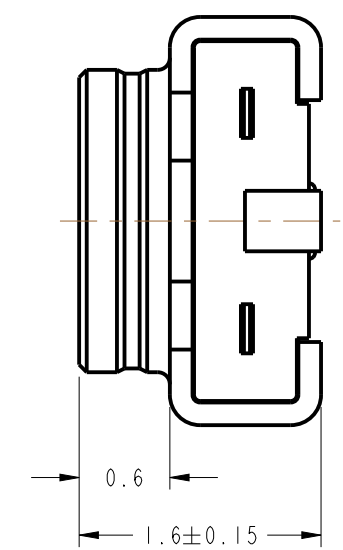
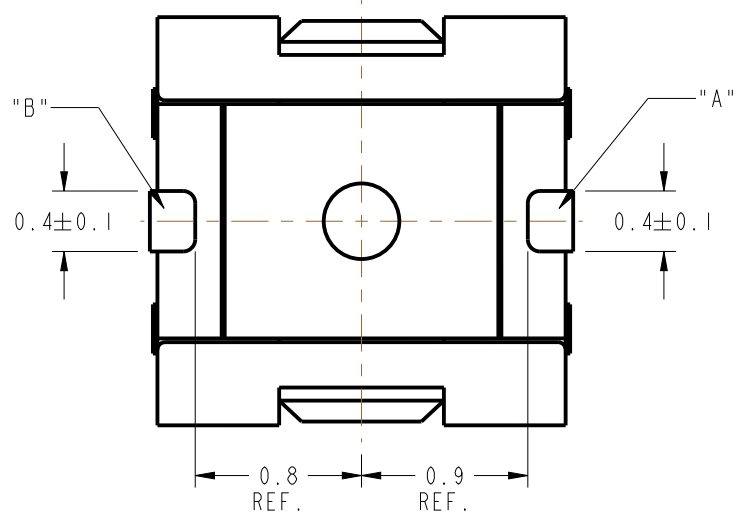
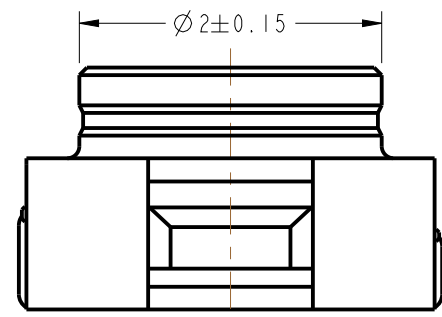
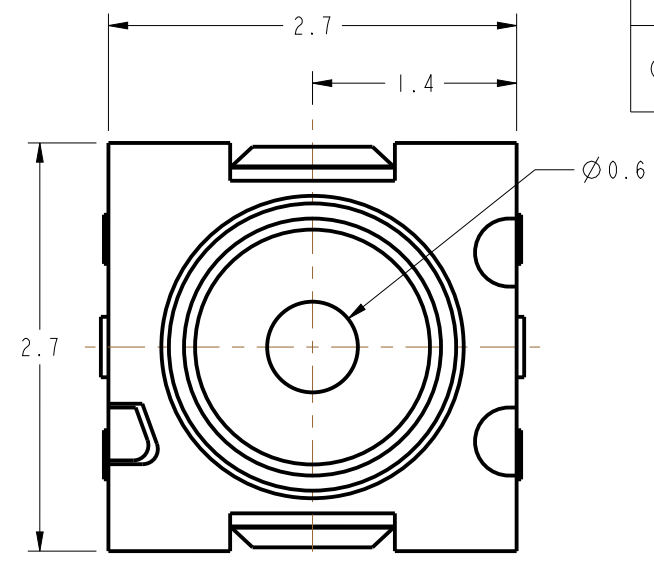
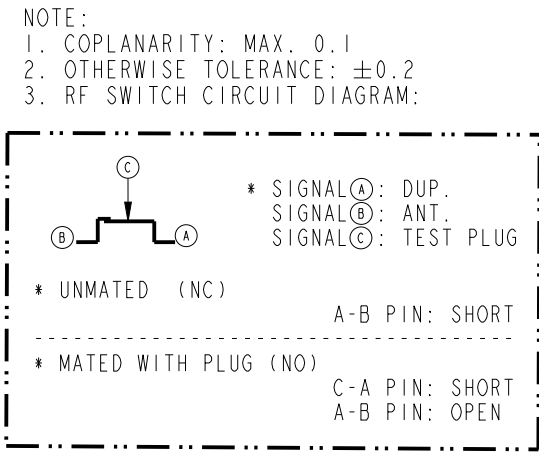

SCALE 10.000

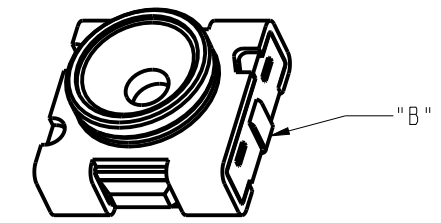

SCALE 10.000

CUSTOMER OUTLINE DRAWING
 ALL OTHER SHEETS ARE FOR INTERNAL USE ONLY

UNLESS OTHERWISE SPECIFIED, DIMENSIONS ARE IN METRIC AND TOLERANCES ARE: <0.5mm ±0.05mm 0.5 - 6mm ±0.1mm 6 - 30mm ±0.2mm 30 - 120mm ±0.3mm ANGLES ±1°	MATERIAL	DRAWN	DATE	TITLE		Amphenol RF www.amphenolrf.com	
	SEE NOTES	TANGOR	08-Oct-14				
	REFERENCE	ENGINEER	DATE	SCALE: 20.0:1.0 SHEET 2 OF 3		DRAWING NO. 902-9049	
	EAR # 3211	T. COVERSTONE	02-Feb-09			ITEM NO. 902-9049	
CONFIGURATION LEVEL:	APPROVED	DATE	DWG SIZE		PART NO. 902-9049		
	K. CAPOZZI	2/5/09			B		REV C
FINISH	CAD FILE						

NOTICE - These drawings, specifications, or other data (1) are, and remain the property of Amphenol corp. (2) must be returned upon request; and (3) are confidential and not to be disclosed to any person other than those to whom they are given by Amphenol Corp. the furnishing of these drawings, specifications, or other data by Amphenol Corp., or to any other person to anyone for any purpose is not to be regarded by implication or otherwise in any manner licensing, granting rights to permitting such holder or any other person to manufacture, use or sell any product, process or design, patented or otherwise, that may in any way be related to or disclosed by said drawings, specifications, or other data.